



SKOOKUM®

Guaranteed Tough Since 1890

2021 EDITION PDF

PRODUCT CATALOG

WWW.SKOOKUMTOUGH.COM

SKOOKUM®

Guaranteed Tough Since 1890

Skookum Tough Since 1890

Skookum is a Chinook word with many meanings:

Strong. Best. Powerful. Brave. Hardworking. Tough.

It was the northwest loggers who gave the name to Skookum products for their unfailing dependability and rugged strength.

From this rough and tumble start in 1890, Skookum has remained a leader in the industry with an unwavering commitment to quality, strength and innovation for over 120 years.

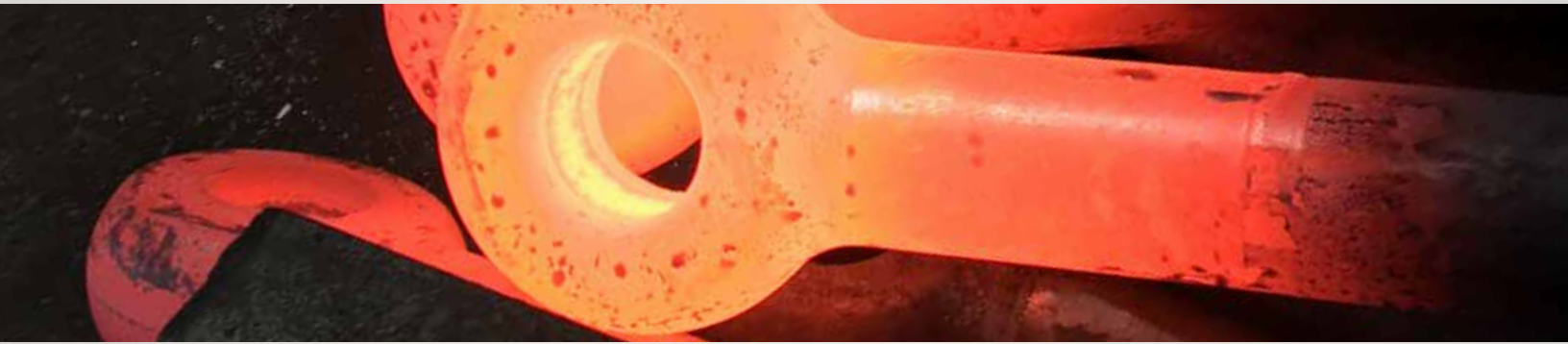

Part of Our History and Future

Skookum has not only been made in U.S.A. since it's beginnings in 1890, it has been a part of American history as well. We have participated in salvage operations at Pearl Harbor, the construction of Grand Coulee Dam, and building the BART in San Francisco. Having already been a part of history, our promise is to lead the way in the development of advanced rigging products with incredible strength and durability to be worthy of the name Skookum.



- Closed Die Forging
- Superior grain refinement & orientation
- Exceptional strength
- Enhanced mechanical properties
- Superior surface finish
- Structural uniformity
- Statistically repeatable dimensions

State of the Art Engineering

- 3D Solid Modeling Employed in Every Design
- Analytical Forge Die Design using Plastic Deformation Modeling
- Forging Dies are CNC manufactured to drive exceptional consistency and maximize quality
- Every theoretical design is validated with destructive testing
- Quality plan defined through the process to ensure consistent quality
- Rapid design and prototyping capability to meet or exceed short cycle custom customer needs

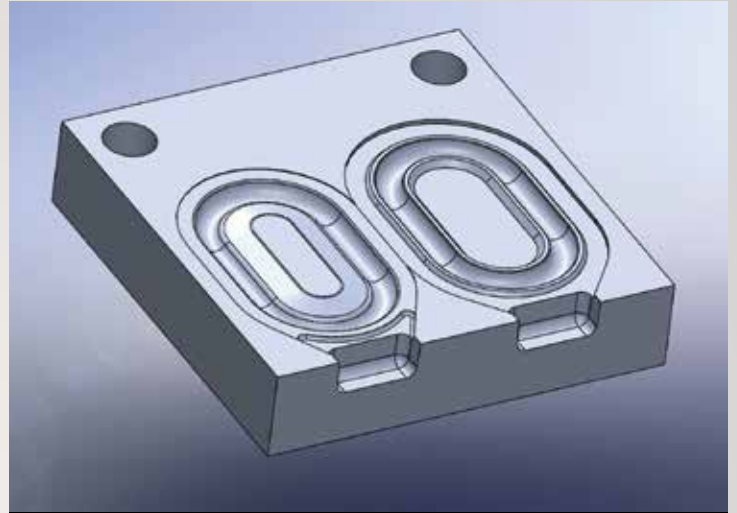

Robotic Welding

- Dramatically improves weld quality and consistency/repeatability
- Final cap weld eliminates the need for hand finishing of welds
- Greater process reliability and manufacturing flexibility
- Exceptional part quality
- Reduced cycle times



Guaranteed Tough Since 1890

GENERAL INDEX

BLOCK PRODUCTS

Lightweight Snatch Block	10-11
Alloy Snatch Block	12-13
Half Sided Block A Series	14-15
Full Sided Block A Series.....	16-17
Snatch Lock Full Sided Block S Series	18-19
Utili-Sheave Full-Sided Blocks R Series	20-21
Wide Throat & Utili-Sheave Blocks Extended R Series	22-23
Half Sided Block 400 Series	24-25
Half Sided Block T Series.....	26-27
Half-Sided and Full-Sided Blocks 2200 Series.....	28-39
Full-Sided Blocks 300/2000/2600 Series	30-31
Aluminum Utili-Sheave Block	32-33
Half Sided Block Ropemaster Series	34-35
Full Sided Block Ropemaster Series.....	36-37
Skookum Trawl Block Series	38-39
Trawl Half-Side Block BCM Series.....	40-41
Trawl Full-Sided Block BCM Series	42-43
Wide Try Net	44-45
Outrigger Blocks	46-47

SHEAVE PRODUCTS

Manganese and Cast Steel	49-50
--------------------------------	-------

FAIRLEADS PRODUCTS

Balanced Head Fairleads Single Sheave - Flange Mounted	53
Balanced Head Fairleads Single Sheave - Deck Mounted.....	54
Balanced Head Fairleads Double Sheave - Flange Mounted.....	55
Unbalanced Head Fairleads Single Sheave - Flange Mounted	56
Vertical Lead Sheaves Weld-Down or Bolt-Down Bases	57
Horizontal Lead Sheaves Weld-Down or Bolt-Down Bases	58
Horizontal Deck Sheaves 'O' and 'R' Style.....	59
Roller Fairleads Bolt-Down Style.....	60



Guaranteed Tough Since 1890

GENERAL INDEX

SHACKLE PRODUCTS

Mandel Fairlead Shackle	63
SmartShackle Series	64-65
Alloy Chain Shackle	66
Alloy Anchor Shackle	67
Sheet Pile Shackle and Ground Release.....	68-69

LINK PRODUCTS

Masterlink.....	72
Pear Link.....	73
Masterlink Sub Assembly	74
Pear Link Sub Assembly	75

FORESTY PRODUCTS

110 Flush Pin Shackle, 110S Flat Bottom / Flush Pin Shackle, 112 Arch Hook Shackle.....	80
174 Butt Rigging Shackle, 118i Intergal Swivel Buzzard Hook, 117 Buzzard Hook	81
113 Cross Eye / (Reverse Eye), 114 Straight Eye / (Regular Eye), 115 Line Hook (Cross Eye).....	82
L115 Line Hook (Straight Eye), 116 Flat Choker Hook, 125 Skidding Tongs	83
126 Guyline Sleeve With Bolt & Nut, 128 Splicing Hammer, 146 Sledge Hammer	84
137 Strawline Swivel, 131 Strawline Hook, 151 Trailer Loading Hook, 154 Dropline Socket	85
152 Splitting Froe, 158 Aluminum Head Froe Hammer, 120 Alloy Rings, Marlin Spikes	86
“Clark” Swivels, Double Ender Hooks, 31 SKM RR Car Hook, Drawbar Protector Arcs	87

RAILROAD & CONSTRUCTION

Car Wheel Hook, Car Puller Hook, Manhole Pins	88
---	----

MAINTENANCE & WARNINGS	89-91
------------------------------	-------

METRIC/DECIMAL EQUIVALENTS.....	92
---------------------------------	----

WARRANTY	93
----------------	----

Blocks Products

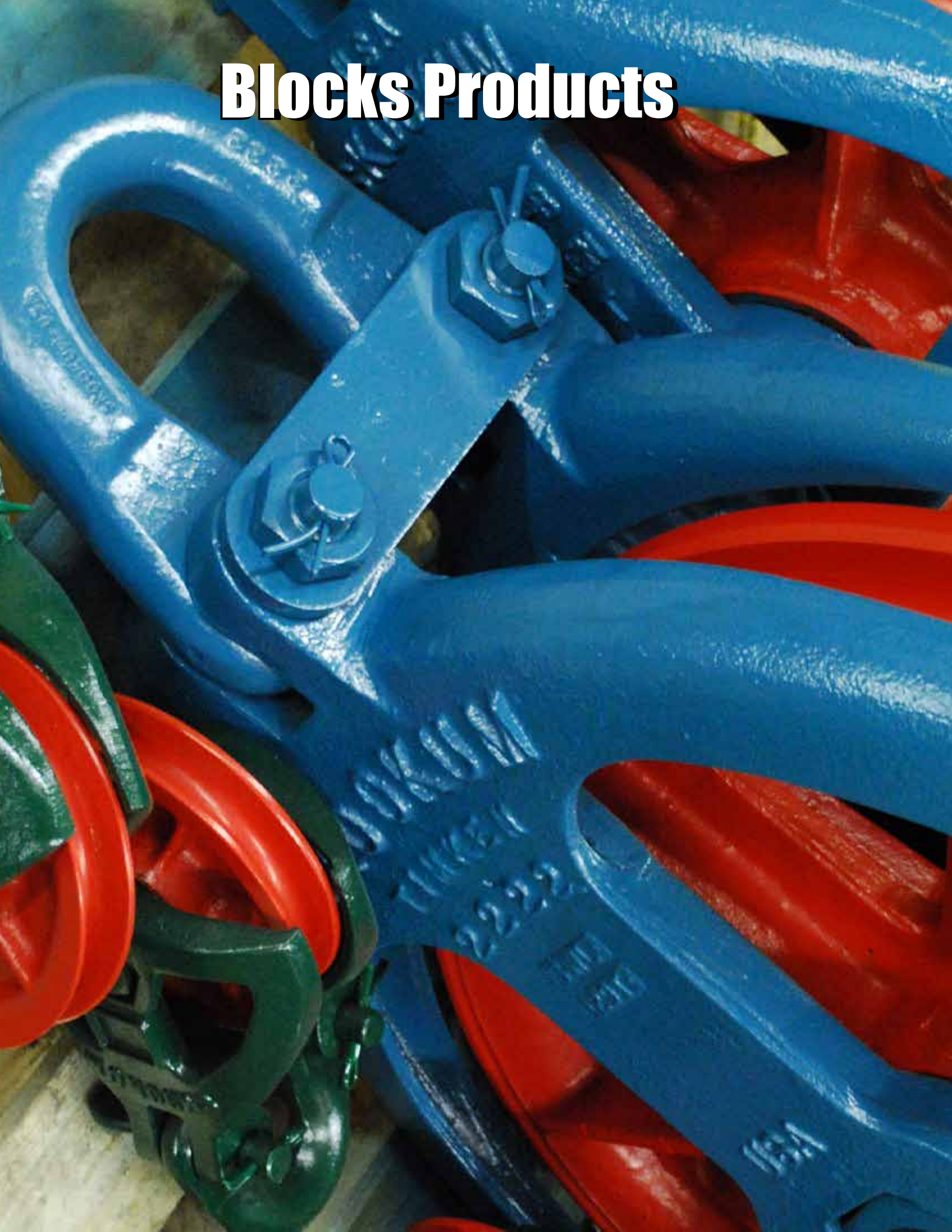

INSIDE SKOOKUM BLOCKS

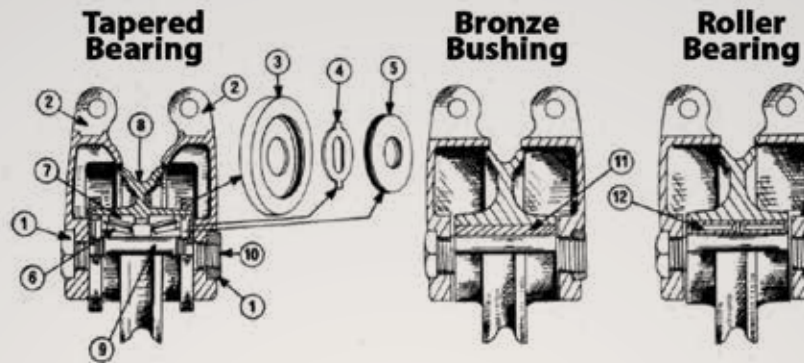

1. **SHEAVE PIN NUT:** There is one on each end of the sheave pin. These nuts are a primary element of the block and hold the assembly together
2. **BLOCK SIDE:** The two block sides comprise the main frame of the block assembly. Their shape and weight are critical factors in how a block performs its functions. Made of cast alloy steel or plate alloy steel – with special alloys employed for special requirements
3. **OPTIONAL SANDSEAL:** Keeps contamination out of the bearing in underwater use. Special order item only
4. **RETAINER LOCK:** The oblong hole of the retainer lock connects to a corresponding flange on the sheave pin. When in place, the tabs on the outer edge engage with the adjustable bearing retainer
5. **ADJUSTABLE BEARING RETAINER:** a grooved disk with rubberized composite material designed to keep the bearing cones tight against the bearing cups. Also provides an effective grease seal for the bearing assembly
6. **BEARING CONE:** The inner race of each roller bearing assembly.
7. **BEARING CUP:** The outer race of each roller bearing assembly.
8. **SHEAVE:** Made from manganese or alloy steel.
9. **SHEAVE PIN:** The precision machined axle on which the sheave rotates.
10. **GREASE HOLE:** The sheave pin is bored through the center, intersecting with a cross-hole that channels grease directly to the bearing assembly. Screw plugs seal the grease hole during use.
11. **BRONZE BUSHING:** Precision-machined bronze bushing is held in the hub of the sheave with a tight press-fit assembly process. It rotates directly on the sheave pin surface that has been ground and polished for minimal friction.
12. **ROLLER BEARINGS:** Feature double rows of low friction roller bearings – either straight or tapered.

Common Abbreviations and References:

BEARING TYPES:

BB – Bronze Bushing
 RB – Roller Bearings
 TRB – Tapered Roller Bearings

DIMENSIONS:

All sizes are shown in Inches unless specified
 All weights are shown in Pounds or Tons unless specified
 Tons = 2,000lbs
 WLL = Working Load Limit

INDUSTRY ICONS on each are intended as a guide for the common usage and applications for each category of blocks:



Energy Exploration
and Production



Construction and Industrial



Marine and Fishing



Forestry

ATTACHMENTS ICONS are intended as a quick reference guide for the various configurations available for each category of blocks:



Swivel Hook



Swivel Shackle



Yoke



Tailboard



Guaranteed Tough Since 1890

Skookum Block Reference Guide

Working Load Limit

MODEL NAME	DESCRIPTION	DIA (IN)	BEARING	TAILBOARD PART	REGULAR YOKE PART	SWIVEL HOOK PART	SWIVEL SHACKLE/ EYE PART	WIRE ROPE MIN (IN)	WIRE ROPE MAX (IN)	WLL	PAGE
3 to 4 Ton WLL											
SK-4	Aluminum Utili-Sheave	4	BB	-	191114	191214	191314	1/4	3/8	3.0	32
SK-4M	Aluminum Utili-Sheave	4	BB	-	191114M	191214M	191314M	1/4	3/8	3.0	32
SK-4R	Aluminum Utili-Sheave	4	RB	-	191104	191204	191304	1/4	3/8	3.0	32
SK-4RM	Aluminum Utili-Sheave	4	RB	-	191104M	191204M	191304M	1/4	3/8	3.0	32
S-4	Snatch Lock Full Sided	4	BB	-	-	749501	749502	1/4	3/8	3.0	18
S-4R	Snatch Lock Full Sided	4	RB	-	-	749601	749602	1/4	3/8	3.0	18
BCM OR 6" 1 sheave	Outrigger	6	BB	-	-	-	305100	7/16	1/2	3.0	46
BCM OR 6" 2 sheave	Outrigger	6	BB	-	-	-	305000	7/16	1/2	3.0	46
6	Full Sided	6	TRB	-	200200	200203	200204	3/8	1/2	3.3	36
62-S	Full Sided	6	TRB	-	203600	203603	203604	3/8	1/2	3.8	46
82-S	Full Sided	8	TRB	-	204800	204803	204804	3/8	1/2	3.8	46
64	Full Sided	6	TRB	-	-	204003	204004	3/8	1/2	3.8	46
4" 4T	Alloy Snatch	4	BB	1000135	-	1000136	1000137	3/8	1/2	4.0	12
5 to 8 Ton WLL											
A-4RT	Full Sided	4	RB	-	680300	680301	680302	1/4	3/8	5.00	16
R-4	Utili-Sheave Full Sided	4	RB	-	565303	-	-	1/4	3/8	5.00	20
A-4	Half Sided	4	BB	-	564000	564001	564002	1/4	3/8	5.00	14
A-4R	Half Sided	4	RB	-	563400	563401	563402	1/4	3/8	5.00	14
A-4T	Full Sided	4	BB	-	666400	666401	666402	1/4	3/8	5.00	16
BCM6	Try Net	6	BB	-	-	-	307797	-	-	5.00	40
BCM FB	Wide Try Net	6	BB	-	-	-	307700	-	-	5.00	44
6" 6T	Lightweight Snatch Block	6	BB	-	-	1007113	-	7/16	1/3	6	10
106	Half Sided	6	TRB	-	205600	205602	205601	3/8	1/2	6.25	34
108RA	Half Sided	8	TRB	-	205800A	205801A	205802A	1/2	5/8	6.25	34
A-6R	Half Sided	6	RB	-	563500	563501	563502	3/8	1/2	6.50	14
A-6RT	Full Sided	6	RB	-	680600	680601	680602	3/8	1/2	6.50	16
S-6	Snatch Lock Full Sided	6	BB	-	-	563001	563002	3/8	1/2	6.50	18
S-6R	Snatch Lock Full Sided	6	RB	-	-	562601	562602	3/8	1/2	6.50	18
A-8R	Half Sided	8	RB	-	563600	563601	563602	1/2	5/8	6.50	14
A-8RT	Full Sided	8	RB	-	680900	680901	680902	1/2	5/8	6.50	16
S-8R	Snatch Lock Full Sided	8	RB	-	-	562701	562702	1/2	5/8	6.50	18
A-10R	Half Sided	10	RB	-	563700	563701	563702	5/8	3/4	6.50	14
A-10RT	Full Sided	10	RB	-	563800	563801	563802	5/8	3/4	6.50	16
S-10R	Snatch Lock Full Sided	10	RB	-	-	562901	562902	5/8	3/4	6.50	18
A-6	Half Sided	6	BB	-	564100	564101	564102	3/8	1/2	7.00	14
A-6T	Full Sided	6	BB	-	679700	679701	679702	3/8	1/2	7.00	16
TR-6A	Wide Throat Full Sided	6	TRB	-	571600	-	571602	3/8	1/2	7.00	22
S-8	Snatch Lock Full Sided	8	BB	-	-	563101	563102	1/2	5/8	7.00	18
S-10	Snatch Lock Full Sided	10	BB	-	-	563301	563302	5/8	3/4	7.00	18
R-6	Utili-Sheave Full Sided	6	TRB	-	551100	-	-	3/8	1/2	8.00	20
A-8	Half Sided	8	BB	-	564200	564201	564202	1/2	5/8	8.00	14
A-8T	Full Sided	8	BB	-	680000	680001	680002	1/2	5/8	8.00	16
R-8	Utili-Sheave Full Sided	8	TRB	-	557700	-	-	1/2	5/8	8.00	20
T-8	Half Sided	8	TRB	-	557903	557901	557902	1/2	5/8	8.00	26
110RA	Half Sided	10	TRB	-	206000A	206001A	206002A	1/2	5/8	8.00	34
112RA	Half Sided	12	TRB	-	206200A	206201A	206202A	1/2	5/8	8.00	34
6" 8T	Alloy Snatch	6	BB	1000141	-	1000142	1000143	5/8	3/4	8.00	12
8" 8T	Alloy Snatch	8	BB	1000144	-	1000145	1000146	5/8	3/4	8.00	12
10" 8T	Alloy Snatch	10	BB	1000150	-	1000151	1000152	5/8	3/4	8.00	12
A-10	Half Sided	10	BB	-	564300	564301	564302	5/8	3/4	8.00	14
A-10T	Full Sided	10	BB	-	564400	564401	564402	5/8	3/4	8.00	16
T-10S	Half Sided	10	TRB	-	558003	558001	558002	5/8	3/4	8.00	26
9 to 15 Ton WLL											
R-10	Utili-Sheave Full Sided	10	TRB	-	557800	-	-	1/2	5/8	9.00	20
808	Utili-Sheave Full Sided	8	TRB	-	799400	799401	799402	1/2	5/8	10.00	22
TB10W	Trawl	10	TRB	-	-	-	560110	-	-	10.00	38
BCM8	Try Net	8	RB	-	-	-	307800	-	-	10.00	40
BCM12	Trawl	12	TRB	-	-	-	307912	-	-	10.00	40
BCM12FS	Trawl	12	TRB	-	-	-	307912T	-	-	10.00	42
BCM SFB	Wide Try Net	6	BB	-	-	-	308800	-	-	10.00	44

Larger Sizes Available by Request

BB – BRONZE BUSHING RB – ROLLER BEARINGS TRB – TAPERED ROLLER BEARINGS



Guaranteed Tough Since 1890

Skookum Block Reference Guide

Working Load Limit

MODEL NAME	DESCRIPTION	DIA (IN)	BEARING	TAILBOARD PART	REGULAR YOKE PART	SWIVEL HOOK PART	SWIVEL SHACKLE/EYE PART	WIRE ROPE MIN (IN)	WIRE ROPE MAX (IN)	WLL	PAGE
9 to 15 Ton WLL											
6" 10T	Lightweight Snatch Block	6	BB	--	--	100712	--	5/8	3/4	8	10
8" 10T	Lightweight Snatch Block	8	BB	--	--	100711	--	5/8	3/4	10	10
410-A	Half Sided	10	TRB	--	553303	--	553302	5/8	3/4	12.50	24
A-12R	Half Sided	12	RB	--	676400	--	676402	3/4	7/8	12.50	14
A-12RT	Full Sided	12	RB	--	571100	--	571102	3/4	7/8	12.50	16
308	Full Sided	8	BB	--	790900	--	--	7/8	1	13.00	30
A-12	Half Sided	12	BB	--	658300	--	658302	3/4	7/8	13.50	16
A-12T	Full Sided	12	BB	--	564500	--	564502	3/4	7/8	13.50	16
10" 15T	Lightweight Snatch Block	8	BB	--	--	1006391	--	3/4	7/8	15	10
513A	Half Sided	13	TRB	--	210001	--	210002	3/8	1/2	15.00	34
8" 15T	Alloy Snatch	8	BB	1000187	--	1000700	1000703	3/4	7/8	15.00	12
10" 15T	Alloy Snatch	10	BB	1000340	--	1000341	1000342	3/4	7/8	15.00	12
210TR	Half Sided	10	TRB	--	206400	--	206402	3/4	7/8	15.00	34
212TR	Half Sided	12	TRB	--	206800	206801	206802	3/4	7/8	15.00	34
515A	Half Sided	15	TRB	--	210201	--	210202	7/8	1	15.00	34
508	Utili-Sheave Full Sided	8	TRB	--	209600	--	--	1	1 1/8	15.00	36
17 to 22 Ton WLL											
412-A	Half Sided	12	TRB	--	558203	--	558202	3/4	7/8	17.50	24
414-A	Half Sided	14	TRB	--	558303	--	558302	3/4	7/8	17.50	24
416-A	Half Sided	16	TRB	--	558403	--	558402	3/4	7/8	17.50	24
416-T	Full Sided	16	TRB	--	573503	--	573502	3/4	7/8	17.50	24
418-A	Half Sided	18	TRB	--	558503	--	558502	7/8	1	17.50	24
414-T	Full Sided	14	TRB	--	573403	--	573402	7/8	1	17.50	24
1010	Half Sided	10	TRB	--	553703	--	553702	7/8	1	17.50	26
510	Half Sided	10	BB	--	565003	--	565002	7/8	1	17.50	26
512	Half Sided	12	BB	--	565103	--	565102	7/8	1	17.50	26
8" 20T	Alloy Snatch	8	BB	1000710	--	1000711	1000712	1	1 1/8	20.00	12
10" 20T	Alloy Snatch	10	BB	1000807	--	1000808	1000809	1	1 1/8	20.00	12
BCM16	Trawl	16	TRB	--	--	--	308357	--	--	20.00	40
BCM18	Trawl	18	TRB	--	--	--	308369	--	--	20.00	40
BCM16FS	Trawl	16	TRB	--	--	--	308357T	--	--	20.00	42
BCM18FS 20T	Trawl	18	TRB	--	--	--	308369T	--	--	20.00	42
BCM16 EWS	Wide Trawl	16	TRB	--	--	--	308357W	--	--	20.00	42
BCM16FS EWS	Wide Trawl	16	TRB	--	--	--	308357TW	--	--	20.00	42
310	Full Sided	10	BB	--	791600	--	--	1 1/8	1 1/4	20.50	30
2210A	Half Sided	10	TRB	--	555003	--	555002	7/8	1	21.50	28
2212	Half Sided	12	TRB	--	558603	--	558602	1 1/8	1 1/4	22.00	28
2214	Half Sided	14	TRB	--	558703	--	558702	1 1/8	1 1/4	22.00	28
23 to 30 Ton WLL											
312	Full Sided	12	BB	--	792200	--	--	1 1/4	1 3/8	23.00	30
TM-10	Utili-Sheave Full Sided	10	TRB	--	108500	--	--	1	1 1/4	25.00	22
2216WA	Utili-Sheave Full Sided	16	TRB	--	560300	--	--	1 1/8	1 1/4	25.00	22
2216B	Half Sided	16	TRB	--	558853	--	558852	1 1/8	1 1/4	25.00	28
TB16W	Trawl	16	TRB	--	--	--	560100	--	--	25.00	38
BCM18FS 25T	Trawl	18	TRB	--	--	--	308870T	--	--	25.00	42
2220	Half Sided	20	TRB	--	715003	--	715002	1	1 1/8	27.50	28
BML12	Full Sided	12	TRB	--	625008.01	--	--	1 1/8	1 1/4	27.50	30
2222	Half Sided	22	TRB	--	711603	--	711602	1 1/8	1 1/4	29.00	28
2216HD	Full Sided	16	TRB	--	558804	--	--	1	1 1/8	30.00	28
2218HD	Full Sided	18	TRB	--	558904	--	--	1 1/8	1 1/4	30.00	28
BCM20	Trawl	20	TRB	--	--	--	308379	--	--	30.00	40
BCM20FS	Trawl	20	TRB	--	--	--	308379T	--	--	30.00	42
36 to 90 Ton WLLv											
2014	Full Sided	14	BB	--	565700	--	--	1 1/2	1 5/8	36.50	30
2016	Full Sided	16	BB	--	565800	--	--	1 1/2	1 5/8	40.50	30
2616	Full Sided	16	TRB	--	559400	--	--	1 1/2	1 5/8	50.00	30
TB24W	Trawl	24	TRB	--	--	--	560150	--	--	50.00	38
2624	Full Sided	24	TRB	--	559500	--	559501	1 1/2	1 5/8	75.00	30
TB30W	Trawl	30	TRB	--	--	--	560175	--	--	90.00	38

Larger Sizes Available By Request

BB – BRONZE BUSHING RB – ROLLER BEARINGS TRB – TAPERED ROLLER BEARINGS

Lightweight Snatch Blocks 6 Ton to 15 Ton Working Load Limit

Plate Sided Series



MODEL SHOWN: 10" 15T

- New lightweight design with only 43 lbs for a 15 Ton block
- Innovative lightweight hook combines a custom high strength alloy with a low profile design, creating a tremendous weight to strength ratio
- Lightweight composite sheave is specifically designed for increased strength and durability
- Corrosion resistant Electroless Nickel plating on sides, sheave pin, and attaching pin
- Captured attaching pin allows convenient reeving while block is suspended
- Custom sizes and WLLs available upon request
- Skookum Gold Standard Forgings
- ASTM B30.26 Compliant

SPECIFICATIONS

MODEL #	SHEAVE DIAMETER	BEARING	SWIVEL HOOK #	WIRE ROPE MIN	WIRE ROPE MAX	WLL (TONS)	SWIVEL HOOK WEIGHT	SHEAVE #
6" 6T	6"	BB	1007113	7/16	1/2	6.00	18.00	1007169
6" 10T	6"	BB	1007112	5/8	3/4	10.00	27.00	1007163
8" 10T	8"	BB	1007111	5/8	3/4	10.00	31.00	1007130
10" 15T	10"	BB	1006391	3/4	7/8	15.00	43.00	1006575

- Please specify Part Number, Sheave Size, Working Load Limit (WLL) , Bearing Style and Attaching Style when ordering.
- Ultimate load is four times the WLL. (4:1)
- Ton equals 2,000 lbs.

WARNING: Misuse of rigging equipment can result in serious injury up to and including loss of life. Only competent trained professionals should use Skookum products. Thoroughly inspect all equipment before each and every use and never use damaged or worn products. Skookum disclaims any liability resulting from the misuse of its products. Please take a moment to carefully review our maintenance and warnings page for more information.

Lightweight Snatch Blocks 6 Ton to 15 Ton Working Load Limit

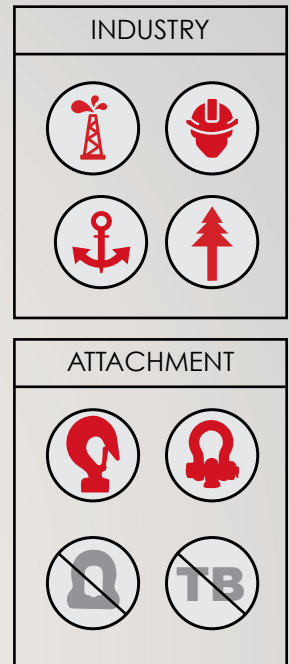
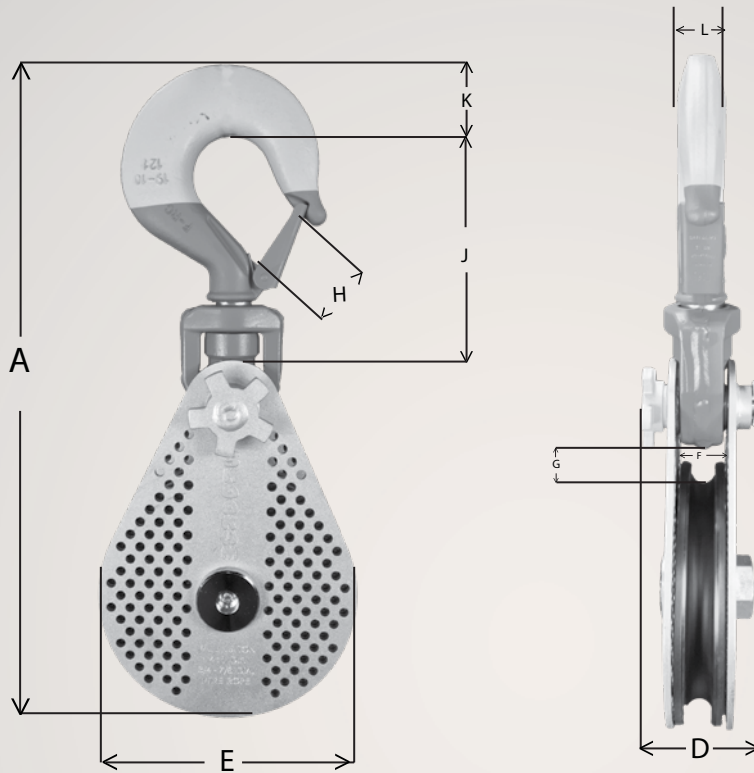

DIMENSIONS (IN)

OVERALL HOOK HEIGHT	OVERALL THICKNESS	OVERALL WIDTH	INSIDE THROAT WIDTH	THROAT HEIGHT	HOOK OPENING W/ LATCH	HOOK HEIGHT	HOOK TOP HEIGHT	HOOK TOP THICK
A	D	E	F	G	H	J	K	L
16.44	4.25	6.25	1.91	1.77	1.38	5.59	1.46	1.18
19.50	4.25	6.25	1.91	1.89	2.09	7.76	2.36	1.69
21.50	4.25	8.25	1.91	1.96	2.09	7.76	2.36	1.69
25.17	4.44	10.25	1.97	2.04	2.10	8.64	2.64	2.05

Please contact us for any custom product or non-standard sizes.



WARNING: Misuse of rigging equipment can result in serious injury up to and including loss of life. Only competent trained professionals should use Skookum products. Thoroughly inspect all equipment before each and every use and never use damaged or worn products. Skookum disclaims any liability resulting from the misuse of its products. Please take a moment to carefully review our maintenance and warnings page for more information.

Alloy Snatch Blocks 4 Ton to 20 Ton Working Load Limit

Plate Sided Series



MODEL SHOWN: 8" 15T

- Forged alloy hooks and shackles heat treated for toughness
- Interchangeable hook and shackle connector options
- Available with bronze bushing, composite bushing or roller bearing
- Captured attaching pin allows convenient reeving while block is suspended
- Larger sheaves and WLL available upon request
- ASTM B30.26 Compliant

SPECIFICATIONS

MODEL #	SHEAVE DIAMETER	BEARING	TAILBOARD	SWIVEL HOOK #	SWIVEL SHACKLE/EYE PART #	WIRE ROPE MIN	WIRE ROPE MAX	WLL (TONS)	TAILBOARD WEIGHT	SWIVEL HOOK WEIGHT	SWIVEL SHACKLE WEIGHT	SHEAVE #
4" 4T	4"	BB	1000135	1000136	1000137	1/4	3/8	4.00	6.30	8.30	9.35	571901
6" 8T	6"	BB	1000141	1000142	1000143	5/8	3/4	8.00	15.75	27.15	23.40	1003066
8" 8T	8"	BB	1000144	1000145	1000146	5/8	3/4	8.00	23.60	34.90	31.05	1002924
8" 15T	8"	BB	1000187	1000700	1000703	3/4	7/8	15.00	29.50	55.85	49.85	1000246
8" 20T	8"	BB	1000710	1000711	1000712	1	1 1/8	20.00	51.85	99.55	88.00	1000722
10" 8T	10"	BB	1000150	1000151	1000152	5/8	3/4	8.00	35.25	46.80	42.90	1003103
10" 15T	10"	BB	1000340	1000341	1000342	3/4	7/8	15.00	38.45	65.00	60.35	1003115
10" 20T	10"	BB	1000807	1000808	1000809	1	1 1/8	20.00	69.85	120.00	106.00	1003129

- Tailboard does not include captured attaching pin.
- Please specify Part Number, Sheave Size, Working Load Limit (WLL) , Bearing Style and Attaching Style when ordering.
- Ultimate load is four times the WLL.
- Ton equals 2,000 lbs.

WARNING: Misuse of rigging equipment can result in serious injury up to and including loss of life. Only competent trained professionals should use Skookum products. Thoroughly inspect all equipment before each and every use and never use damaged or worn products. Skookum disclaims any liability resulting from the misuse of its products. Please take a moment to carefully review our maintenance and warnings page for more information.

Alloy Snatch Blocks 4 Ton to 20 Ton Working Load Limit

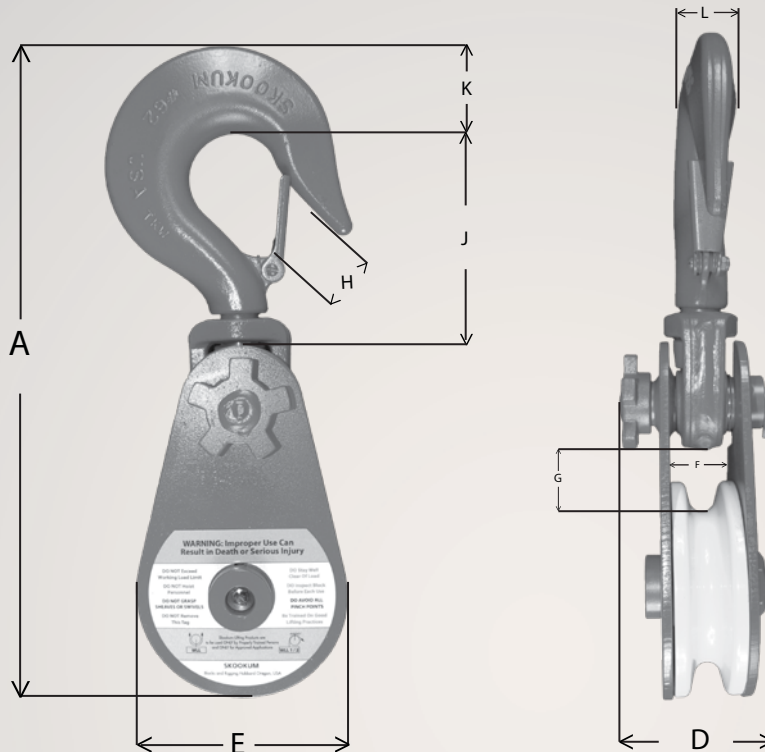

DIMENSIONS (IN)

OVERALL HOOK HEIGHT	OVERALL SHACKLE HEIGHT	OVERALL TAILBOARD HEIGHT	OVERALL THICKNESS	OVERALL WIDTH	INSIDE THROAT WIDTH	THROAT HEIGHT	HOOK OPENING	HOOK HEIGHT	HOOK TOP HEIGHT	HOOK TOP THICK	SHACKLE HEIGHT
A	NOT SHOWN	NOT SHOWN	D	E	F	G	H	J	K	L	NOT SHOWN
13.60	12.75	6.91	3.30	4.06	1.50	1.00	1.35	5.20	1.50	1.13	5.22
18.65	16.46	9.94	4.25	6.00	1.91	1.21	1.70	6.33	2.38	1.50	5.65
20.65	18.46	11.94	4.25	8.00	1.91	1.21	1.70	6.33	2.38	1.50	5.65
23.85	23.13	12.50	4.43	8.25	1.97	1.13	2.77	8.71	2.64	2.02	9.38
26.73	25.69	13.81	6.19	8.13	2.56	1.26	3.51	9.75	3.15	2.52	10.38
22.65	20.46	13.94	4.25	10.00	1.91	1.21	1.70	6.33	2.38	1.50	5.65
25.85	25.13	14.50	4.43	10.25	1.97	1.13	2.77	8.71	2.64	2.02	9.38
28.73	27.69	15.81	6.19	10.13	2.56	1.26	3.51	9.75	3.15	2.52	10.38

Please contact us for any custom product or non-standard sizes.



WARNING: Misuse of rigging equipment can result in serious injury up to and including loss of life. Only competent trained professionals should use Skookum products. Thoroughly inspect all equipment before each and every use and never use damaged or worn products. Skookum disclaims any liability resulting from the misuse of its products. Please take a moment to carefully review our maintenance and warnings page for more information.

Half-Sided Blocks

5 Ton to 12.5 Ton Working Load Limit

A Series



MODEL SHOWN: A-6

- Work hardening manganese steel sheaves maximize wire rope and sheave life
- Recessed sheave design prevents wire rope from binding between sheave and block side
- Half side design for strength with minimized weight
- Versatile draw pin design allows for rapid reeving and exchange of attaching style
- Rugged cast alloy steel sides for demanding environments
- ASTM B30.26 Compliant

SPECIFICATIONS

MODEL #	SHEAVE DIAMETER	BEARING	REGULAR YOKE PART #	SWIVEL HOOK PART #	SWIVEL SHACKLE PART #	WIRE ROPE MIN	WIRE ROPE MAX	WLL (TONS)	REGULAR YOKE WEIGHT	SWIVEL HOOK WEIGHT	SWIVEL SHACKLE WEIGHT
A-4	4"	BB	564000	564001	564002	1/4	3/8	5.00	9.25	12.00	10.50
A-6	6"	BB	564100	564101	564102	3/8	1/2	7.00	17.00	20.50	19.00
A-8	8"	BB	564200	564201	564202	1/2	5/8	8.00	23.50	36.00	35.00
A-10	10"	BB	564300	564301	564302	5/8	3/4	8.00	34.00	40.00	41.00
A-12	12"	BB	658300	—	658302	3/4	7/8	13.50	53.40	—	58.65
A-4R	4"	RB	563400	563401	563402	1/4	3/8	5.00	9.00	11.75	10.25
A-6R	6.00	RB	563500	563501	563502	3/8	1/2	6.50	17.00	20.50	19.00
A-8R	8"	RB	563600	563601	563602	1/2	5/8	6.50	23.55	35.00	35.00
A-10R	10"	RB	563700	563701	563702	5/8	3/4	6.50	37.00	41.00	41.00
A-12R	12"	RB	676400	676401	676402	3/4	7/8	12.50	55.00	—	59.00

- Please specify Part Number, Sheave Size, Working Load Limit (WLL), Bearing Style and Attaching Style when ordering.
- Ultimate load for swivel attachments is four times the WLL.
- Ultimate load for yoke attachments is five times WLL.
- Ton equals 2,000 lbs.

WARNING: Misuse of rigging equipment can result in serious injury up to and including loss of life. Only competent trained professionals should use Skookum products. Thoroughly inspect all equipment before each and every use and never use damaged or worn products. Skookum disclaims any liability resulting from the misuse of its products. Please take a moment to carefully review our maintenance and warnings page for more information.

Half-Sided Blocks

5 Ton to 12.5 Ton Working Load Limit

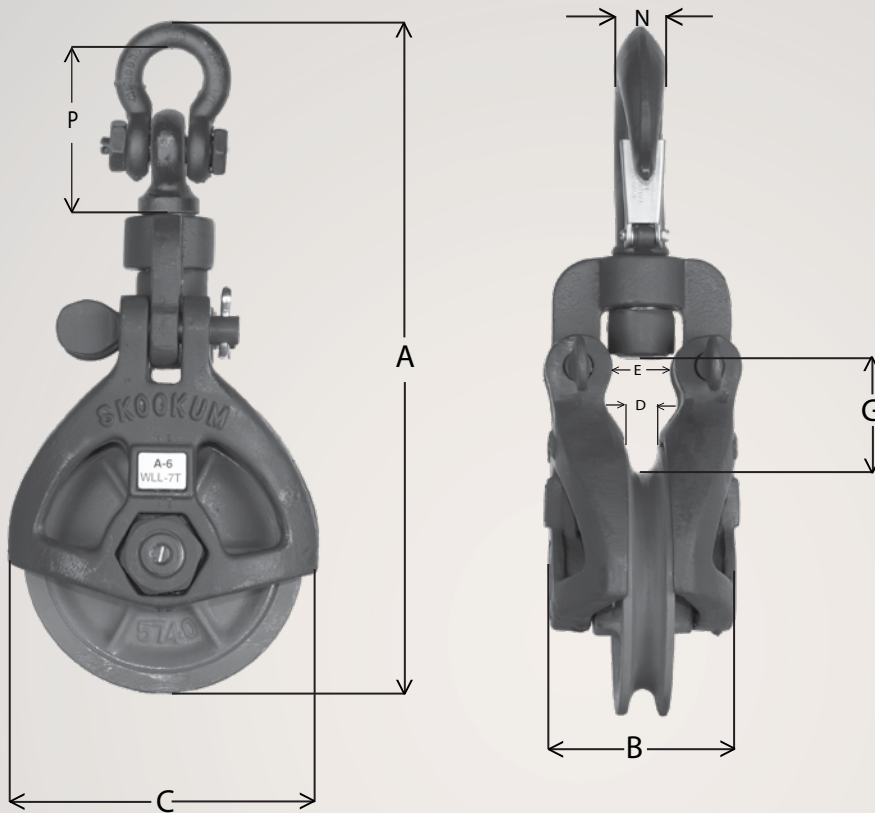

DIMENSIONS (IN)

HEIGHT	THICK NESS	OVERALL WIDTH	THROAT BOTTOM WIDTH	INSIDE THROAT WIDTH	INSIDE YOKE WIDTH	THROAT HEIGHT	YOKE BAR HEIGHT	YOKE BAR WIDTH	HOOK OPENING	HOOK HEIGHT	HOOK TOP HEIGHT	HOOK TOP THICK	SHACKLE HEIGHT
A	B	C	D	E	NOT SHOWN	G	NOT SHOWN	NOT SHOWN	NOT SHOWN	NOT SHOWN	NOT SHOWN	N	P
7.75	3.50	4.50	1.13	1.13	1.43	3.88	0.88	0.75	1.13	3.25	1.00	1.13	3.50
10.50	4.00	6.50	0.88	1.50	1.13	4.50	1.06	1.25	1.25	3.63	1.60	1.25	4.50
14.50	4.00	9.00	1.00	1.75	1.50	5.00	1.13	1.38	1.50	4.19	1.88	1.37	5.00
16.50	4.00	11.00	1.00	1.38	1.50	6.00	1.13	1.38	1.50	4.19	1.88	1.37	5.00
19.75	6.25	12.50	1.25	1.75	1.75	7.25	1.44	1.38	—	—	—	—	5.50
7.75	3.50	4.50	1.13	1.13	1.43	3.88	0.88	0.75	1.13	3.25	1.00	1.13	3.50
10.50	4.00	6.50	0.88	1.50	1.13	4.50	1.06	1.25	1.25	3.63	1.60	1.25	4.50
14.50	4.00	9.00	1.00	1.75	1.50	5.00	1.13	1.38	1.50	4.19	1.88	1.37	5.00
16.50	4.00	11.00	1.00	1.38	1.50	6.00	1.13	1.38	1.50	4.19	1.88	1.37	5.00
19.75	6.25	12.50	1.25	1.75	1.75	7.25	1.44	1.38	—	—	—	—	5.50

Please contact us for any custom product or non-standard sizes.



WARNING: Misuse of rigging equipment can result in serious injury up to and including loss of life. Only competent trained professionals should use Skookum products. Thoroughly inspect all equipment before each and every use and never use damaged or worn products. Skookum disclaims any liability resulting from the misuse of its products. Please take a moment to carefully review our maintenance and warnings page for more information.

Full-Sided Blocks 5 Ton to 13.5 Ton Working Load Limit

A Series



MODEL SHOWN: A-6RT

- Work hardening manganese steel sheaves maximize wire rope and sheave life
- Recessed sheave design prevents wire rope from binding between sheave and block side
- Full sided block maximizes sheave protection and strength
- Versatile draw pin design allows for rapid reeving and exchange of attaching style
- Rugged cast alloy steel sides for demanding environments
- ASTM B30.26 Compliant

SPECIFICATIONS

MODEL #	SHEAVE DIAMETER	BEARING	REGULAR YOKE PART #	SWIVEL HOOK PART #	SWIVEL SHACKLE PART #	WIRE ROPE MIN	WIRE ROPE MAX	WLL (TONS)	REGULAR YOKE WEIGHT	SWIVEL HOOK WEIGHT	SWIVEL SHACKLE WEIGHT
A-4T	4"	BB	666400	666401	666402	1/4	3/8	5.00	13.00	16.25	16.25
A-6T	6"	BB	679700	679701	679702	3/8	1/2	7.00	20.00	24.00	22.00
A-8T	8"	BB	680000	680001	680002	1/2	5/8	8.00	31.00	38.00	37.00
A-10T	10"	BB	564400	564401	564402	5/8	3/4	8.00	37.00	43.00	44.00
A-12T	12"	BB	564500	—	564502	3/4	7/8	13.50	60.00	—	68.00
A-4RT	4"	RB	680300	680301	680302	1/4	3/8	5.00	13.00	16.25	16.25
A-6RT	6"	RB	680600	680601	680602	3/8	1/2	6.50	20.00	24.00	22.00
A-8RT	8"	RB	680900	680901	680902	1/2	5/8	6.50	31.00	38.00	37.00
A-10RT	10"	RB	563800	563801	563802	5/8	3/4	6.50	40.00	44.00	44.00
A-12RT	12"	RB	571100	571101	571102	3/4	7/8	12.50	60.00	64.00	64.00

- Please specify Part Number, Sheave Size, Working Load Limit (WLL), Bearing Style and Attaching Style when ordering.
- Ultimate load for swivel attachments is four times the WLL.
- Ultimate load for yoke attachments is five times WLL.
- Ton equals 2,000 lbs.

WARNING: Misuse of rigging equipment can result in serious injury up to and including loss of life. Only competent trained professionals should use Skookum products. Thoroughly inspect all equipment before each and every use and never use damaged or worn products. Skookum disclaims any liability resulting from the misuse of its products. Please take a moment to carefully review our maintenance and warnings page for more information.

Full-Sided Blocks

5 Ton to 13.5 Ton Working Load Limit

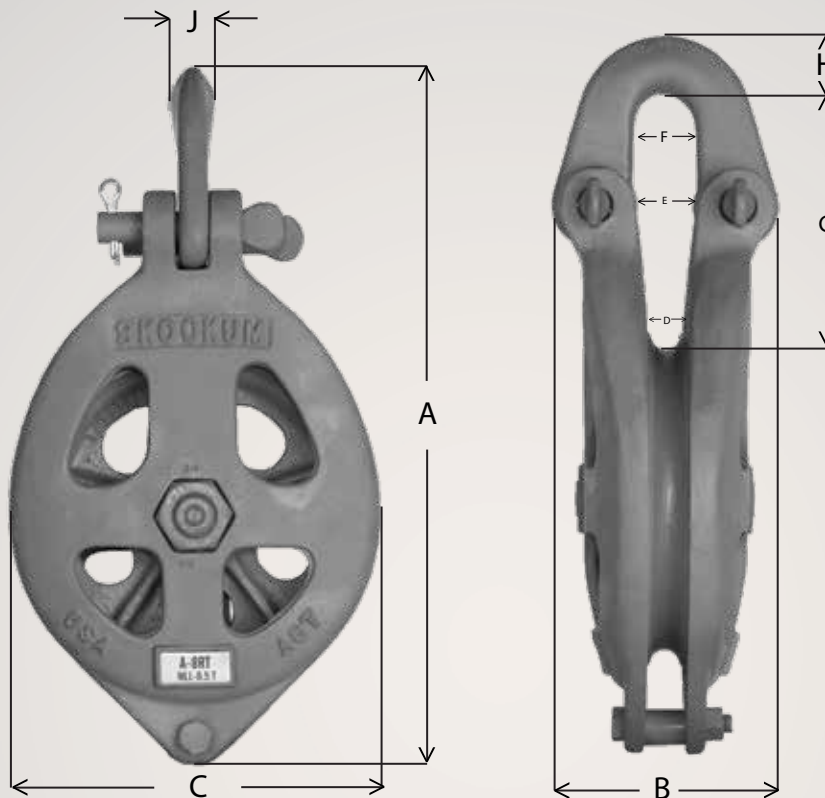

DIMENSIONS (IN)

HEIGHT	THICK NESS	WIDTH	THROAT BOTTOM WIDTH	INSIDE THROAT WIDTH	INSIDE YOKE WIDTH	THROAT HEIGHT	YOKE BAR HEIGHT	YOKE BAR WIDTH	HOOK OPENING	HOOK HEIGHT	HOOK HEIGHT TOP	HOOK TOP THICK	SHACKLE HEIGHT
A	B	C	D	E	F	G	H	J	NOT SHOWN	NOT SHOWN	NOT SHOWN	NOT SHOWN	NOT SHOWN
9.63	3.50	4.50	1.13	1.50	1.43	3.50	0.88	0.75	1.13	3.25	1.00	1.13	3.50
12.00	4.00	6.50	0.88	1.50	1.13	4.50	1.06	1.25	1.25	3.63	1.60	1.25	4.50
16.38	4.00	8.63	1.00	1.50	1.50	5.75	1.13	1.38	1.38	4.16	1.88	1.37	5.00
18.50	4.00	11.00	1.00	1.50	1.50	6.00	1.13	1.38	1.38	4.19	1.88	1.37	5.00
21.00	6.25	12.50	1.00	1.75	1.75	7.25	1.44	1.38	—	—	—	—	5.50
9.63	3.50	4.50	1.13	1.50	1.43	3.50	0.88	0.75	1.13	3.25	1.00	1.13	3.50
12.00	4.00	6.50	0.88	1.50	1.13	4.50	1.06	1.25	1.25	3.63	1.60	1.25	4.50
16.38	4.00	8.63	1.00	1.50	1.50	5.75	1.13	1.38	1.38	4.19	1.88	1.37	5.00
18.50	4.00	11.00	1.00	1.50	1.50	6.00	1.13	1.38	1.38	4.19	1.88	1.37	5.00
21.00	6.25	12.50	1.00	1.75	1.75	7.25	1.44	1.38	—	—	—	—	5.50

Please contact us for any custom product or non-standard sizes.



WARNING: Misuse of rigging equipment can result in serious injury up to and including loss of life. Only competent trained professionals should use Skookum products. Thoroughly inspect all equipment before each and every use and never use damaged or worn products. Skookum disclaims any liability resulting from the misuse of its products. Please take a moment to carefully review our maintenance and warnings page for more information.

Snatch Lock Full-Sided Blocks 3 Ton to 6.5 Ton Working Load Limit

S Series

- Unique Snatch Lock designed for fast, tool-less reeving
- Work hardening manganese steel sheaves maximize wire rope and sheave life
- Recessed sheave design prevents wire rope from binding between sheave and block side
- Full sided block maximizes sheave protection and strength
- Versatile draw pin design allows for rapid reeving and exchange of attaching style
- Rugged cast alloy steel sides for demanding environments
- ASTM B30.26 Compliant



MODEL SHOWN: S-6

SPECIFICATIONS

MODEL #	SHEAVE DIAMETER	BEARING	SWIVEL HOOK PART #	SWIVEL SHACKLE PART #	WIRE ROPE MIN	WIRE ROPE MAX	WLL (TONS)	SWIVEL HOOK WEIGHT	SWIVEL SHACKLE WEIGHT	SHEAVE #	DRAW PIN
S-4	4"	BB	749501	749502	3/8	1/2	3.00	11.00	11.00	571901	551401
S-6	6"	BB	563001	563002	3/8	1/2	6.50	26.00	26.00	574001	551413
S-8	8"	BB	563101	563102	1/2	5/8	7.00	32.00	32.00	574201	551413
S-10	10"	BB	563301	563302	5/8	3/4	7.00	44.00	44.00	574401	551413
S-4R	4"	RB	749601	749602	3/8	1/2	3.00	11.00	11.00	571902	551401
S-6R	6"	TRB	562601	562602	3/8	1/2	6.50	26.00	26.00	574005	551413
S-8R	8"	TRB	562701	562702	1/2	5/8	6.50	32.00	32.00	574205	551413
S-10R	10"	TRB	562901	562902	5/8	3/4	6.50	44.00	44.00	574405	551413

- Please specify Part Number, Sheave Size, Working Load Limit (WLL), Bearing Style and Attaching Style when ordering.
- Ultimate load for swivel attachments is four times the WLL.
- Ton equals 2,000 lbs.

WARNING: Misuse of rigging equipment can result in serious injury up to and including loss of life. Only competent trained professionals should use Skookum products. Thoroughly inspect all equipment before each and every use and never use damaged or worn products. Skookum disclaims any liability resulting from the misuse of its products. Please take a moment to carefully review our maintenance and warnings page for more information.

Snatch Lock Full Sided-Blocks

3 Ton to 6.5 Ton Working Load Limit

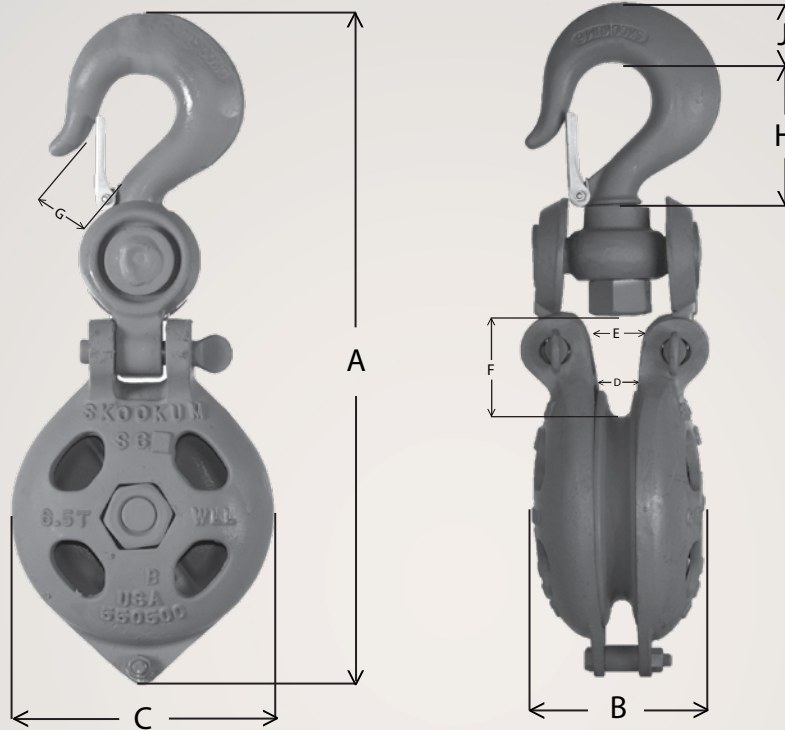

DIMENSIONS (IN)

HEIGHT	THICK-NESS	WIDTH	THROAT BOTTOM	INSIDE THROAT WIDTH	THROAT HEIGHT	HOOK OPENING	HOOK HEIGHT	HOOK TOP THICK-NESS	SHACKLE HEIGHT
A	B	C	D	E	F	G	H	J	NOT SHOWN
12.00	3.50	4.50	1.13	1.25	2.88	1.25	2.88	1.19	0.75
16.75	4.00	7.00	1.00	1.88	2.50	1.88	4.00	1.63	0.88
20.00	4.00	9.00	1.13	1.88	2.50	1.88	4.75	1.63	1.00
22.00	4.00	11.00	1.13	2.00	2.50	2.00	4.75	1.75	1.00
12.00	3.50	4.50	1.13	1.25	2.88	1.25	2.88	1.19	0.75
16.75	4.00	7.00	1.00	1.88	2.50	1.88	4.00	1.63	0.88
20.00	4.00	9.00	1.13	1.88	2.50	1.88	4.75	1.63	1.00
22.00	4.00	11.00	1.13	2.00	2.50	2.00	4.75	1.75	1.00

Please contact us for any custom product or non-standard sizes.



WARNING: Misuse of rigging equipment can result in serious injury up to and including loss of life. Only competent trained professionals should use Skookum products. Thoroughly inspect all equipment before each and every use and never use damaged or worn products. Skookum disclaims any liability resulting from the misuse of its products. Please take a moment to carefully review our maintenance and warnings page for more information.

Utili-Sheave Full-Sided Blocks 5 Ton to 9 Ton Working Load Limit

R Series



MODEL SHOWN: R6

- **New!** Now available with an alloy sheave
- Multi-use wide throat and Utili-Sheave for passing a variety of line, connecting links and terminations
- Work hardening manganese steel sheaves maximize wire rope and sheave life
- R-6, R-8 & R-10 equipped with tapered roller bearings for long life in higher line speed applications
- R-4 feature straight roller bearings to minimize size
- Recessed sheave prevents wire rope from binding between sheave and block side
- Full sided block maximizes sheave protection and strength
- Versatile draw pin design allows for rapid reeving and exchange of attaching style
- Rugged cast alloy steel sides for demanding environments
- ASTM B30.26 Compliant

SPECIFICATIONS

MODEL #	SHEAVE DIAMETER	BEARING	ALLOY BLOCK PART #	MANGANESE BLOCK PART #	WIRE ROPE MIN	WIRE ROPE MAX	WLL (TONS)	BLOCK WEIGHT	ALLOY SHEAVE #	MANGANESE SHEAVE #	DRAW PIN #
R4	4"	RB	565303A	565303	3/8	3/8	5.00	11.45	1009495	571904	551401
R6	6"	TRB	551100A	551100	3/8	1/2	8.00	30	1009496	574803	551413
R8	8"	TRB	557700A	557700	1/2	5/8	8.00	43	1009497	799203	551420
R10	10"	TRB	557800A	557800	1/2	5/8	9.00	50	1009498	539703	551420

- Please specify Part Number, Sheave Size, Working Load Limit (WLL), and Attaching Style when ordering.
- Ultimate load for yoke attachments is five times WLL.
- Ton equals 2,000 lbs.

WARNING: Misuse of rigging equipment can result in serious injury up to and including loss of life. Only competent trained professionals should use Skookum products. Thoroughly inspect all equipment before each and every use and never use damaged or worn products. Skookum disclaims any liability resulting from the misuse of its products. Please take a moment to carefully review our maintenance and warnings page for more information.

Utili-Sheave Full-Sided Blocks

5 Ton to 9 Ton Working Load Limit

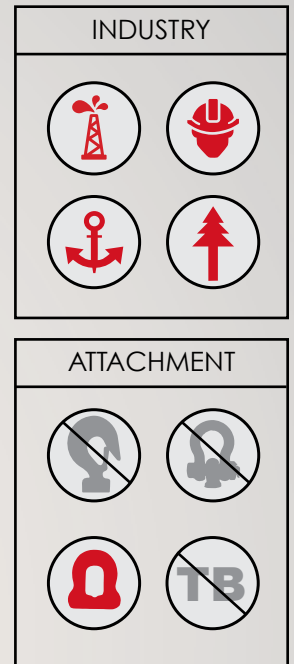
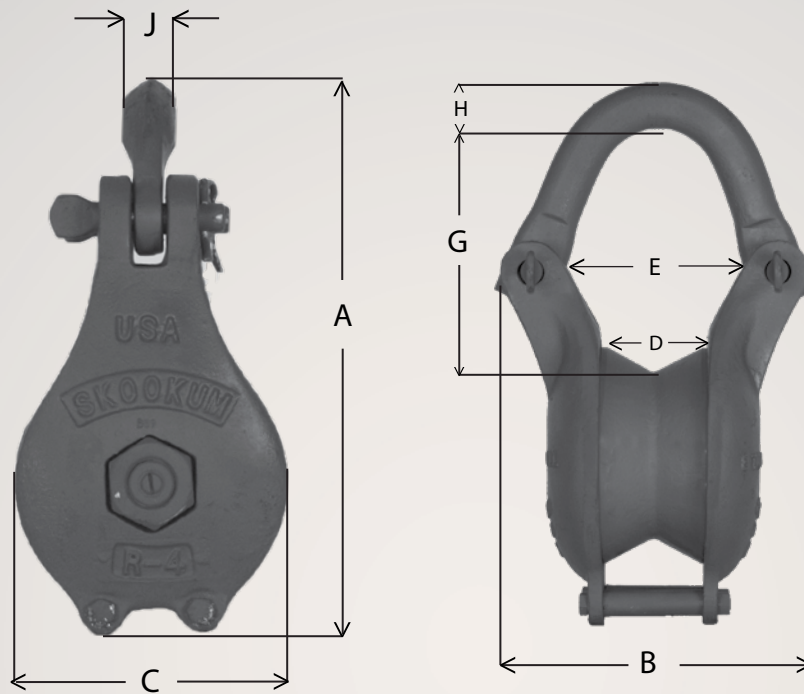

DIMENSIONS (IN)

HEIGHT	THICK- NESS	WIDTH	THROAT BOTTOM	INSIDE THROAT WIDTH	THROAT HEIGHT	YOKE BAR HEIGHT	YOKE BAR WIDTH
A	B	C	D	E	G	H	J
10.00	1.75	4.75	1.00	2.50	5.25	1.00	1.00
14.50	8.00	6.75	2.50	4.50	6.50	1.25	1.25
17.00	8.50	8.75	2.50	4.75	7.25	1.38	1.38
19.50	8.00	10.50	3.50	4.75	7.25	1.38	1.38

Please contact us for any custom product or non-standard sizes.



WARNING: Misuse of rigging equipment can result in serious injury up to and including loss of life. Only competent trained professionals should use Skookum products. Thoroughly inspect all equipment before each and every use and never use damaged or worn products. Skookum disclaims any liability resulting from the misuse of its products. Please take a moment to carefully review our maintenance and warnings page for more information.

Wide Throat & Utili-Sheave Blocks 7 Ton to 25 Ton Working Load Limit

Extended R Series



MODEL SHOWN: 508

- Multi-use wide throat and Utili-Sheave for passing a variety of line, connecting links and terminations
- Work hardening manganese steel sheaves maximize wire rope and sheave life
- Equipped with tapered roller bearings for long life in higher line speed applications
- Recessed sheave prevents wire rope from binding between sheave and block side
- Full sided block maximizes sheave protection and strength
- Versatile draw pin design allows for rapid reeving and exchange of attaching style
- Rugged cast alloy steel sides for demanding environments
- ASTM B30.26 Compliant

SPECIFICATIONS

MODEL	SHEAVE DIAM	BEARING	REGULAR YOKE PART #	SWIVEL HOOK PART #	SWIVEL SHACKLE PART #	WIRE ROPE MIN	WIRE ROPE MAX	WLL (TONS)	REGULAR YOKE WEIGHT	SWIVEL HOOK WEIGHT	SWIVEL SHACKLE WEIGHT	SHEAVE #	DRAW PIN
TR-6A	6"	TRB	571600	—	571602	3/8	1/2	7.00	27.00	—	30.95	538903	551410
808	8"	TRB	799400	799401	799402	1/2	5/8	10.00	32.00	36.00	36.00	799203	551420
508	8"	TRB	209800	—	—	1	1 1/8	15.00	72.00	—	—	226203	551468
TM-10	10"	TRB	108500	—	—	1	1 1/4	25.00	110.00	—	—	108526	108512
TMS-10	10"	TRB	108510	—	—	1	1 1/4	25.00	110.00	—	—	108527	108512
2216WA	16"	TRB	560300	—	—	1 1/8	1 1/4	25.00	285.00	—	—	101983	620801WA

- Please specify Part Number, Sheave Size, Working Load Limit (WLL), Bearing Style and Attaching Style when ordering.
- Ultimate load for swivel attachments is four times the WLL.
- Ultimate load for yoke attachments is five times WLL.
- Ton equals 2,000 lbs.



WARNING: Misuse of rigging equipment can result in serious injury up to and including loss of life. Only competent trained professionals should use Skookum products. Thoroughly inspect all equipment before each and every use and never use damaged or worn products. Skookum disclaims any liability resulting from the misuse of its products. Please take a moment to carefully review our maintenance and warnings page for more information.

Wide Throat & Utili-Sheave Blocks

7 Ton to 25 Ton Working Load Limit

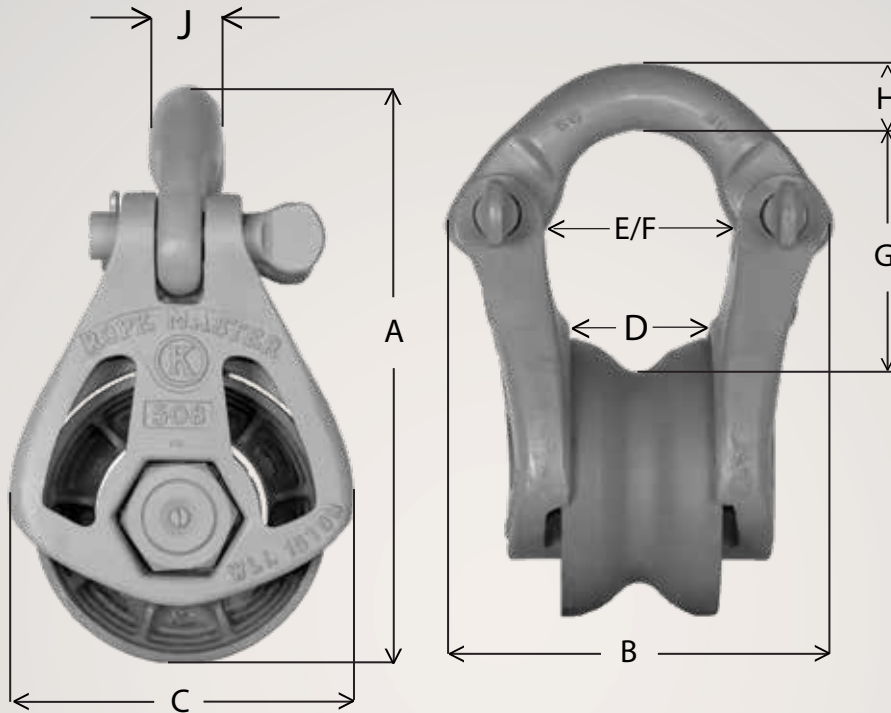

DIMENSIONS (IN)

HEIGHT	THICK-NESS	WIDTH	THROAT BOTTOM	INSIDE THROAT WIDTH	INSIDE YOKE WIDTH	THROAT HEIGHT	YOKE BAR HEIGHT	YOKE BAR WIDTH
A	B	C	D	E	F	G	H	J
13.00	6.00	7.00	1.00	3.00	3.00	5.25	1.00	1.00
17.00	6.50	8.75	2.63	2.63	2.63	3.75	1.38	1.38
15.00	11.00	9.50	4.00	4.00	5.25	6.50	2.00	2.00
15.00	11.00	9.50	4.00	4.00	5.25	6.50	2.00	2.00
20.00	12.00	11.50	4.50	4.50	6.00	9.00	2.00	2.00
30.50	13.63	16.50	6.75	9.50	9.50	15.00	2.38	2.38

Please contact us for any custom product or non-standard sizes.



WARNING: Misuse of rigging equipment can result in serious injury up to and including loss of life. Only competent trained professionals should use Skookum products. Thoroughly inspect all equipment before each and every use and never use damaged or worn products. Skookum disclaims any liability resulting from the misuse of its products. Please take a moment to carefully review our maintenance and warnings page for more information.

Half-Sided Blocks

12.5 Ton to 17.5 Ton Working Load Limit

400-Series



MODEL SHOWN: 412-A

- Work hardening manganese steel sheaves maximize wire rope and sheave life
- Equipped with tapered roller bearings for long life in higher line speed applications
- Recessed sheave prevents wire rope from binding between sheave and block side
- Half side for light weight or full side design to maximize sheave protection
- Versatile draw pin design allows for rapid reeving and exchange of attaching style
- Rugged cast alloy steel sides for demanding environments
- ASTM B30.26 Compliant

SPECIFICATIONS

MODEL	SHEAVE DIAM	BEARING	REGULAR YOKE PART #	SWIVEL SHACKLE PART #	WIRE ROPE MIN	WIRE ROPE MAX	WLL (TONS)	REGULAR YOKE WEIGHT	SWIVEL SHACKLE WEIGHT	SHEAVE #	DRAW PIN
HALF SIDED BLOCK											
410-A	10"	TRB	553303	553302	5/8	3/4	12.50	48.00	55.00	536703	551422
412-A	12"	TRB	558203	558202	3/4	7/8	17.50	72.00	81.15	537103	555501
414-A	14"	TRB	558303	558302	3/4	7/8	17.50	95.75	104.90	537303	555501
416-A	16"	TRB	558403	558402	3/4	7/8	17.50	97.00	106.15	537503	555501
418-A	18"	TRB	558503	558502	7/8	1	17.50	108.00	117.15	537703	555501
FULL SIDED BLOCKS											
414-T	14"	TRB	573403	573402	7/8	1	17.50	97.00	106.15	537303	555501
416-T	16"	TRB	573503	573502	3/4	7/8	17.50	107.00	116.15	537503	555501

- Please specify Part Number, Sheave Size, Working Load Limit (WLL), Bearing Style and Attaching Style when ordering.
- Ultimate load for swivel attachments is four times the WLL.
- Ultimate load for yoke attachments is five times WLL.
- Ton equals 2,000 lbs.

WARNING: Misuse of rigging equipment can result in serious injury up to and including loss of life. Only competent trained professionals should use Skookum products. Thoroughly inspect all equipment before each and every use and never use damaged or worn products. Skookum disclaims any liability resulting from the misuse of its products. Please take a moment to carefully review our maintenance and warnings page for more information.

Half-Sided Blocks

12.5 Ton to 17.5 Ton Working Load Limit

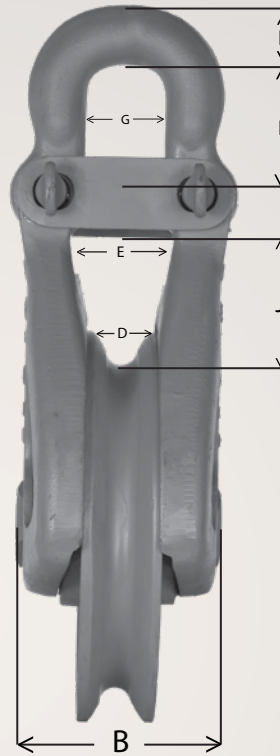
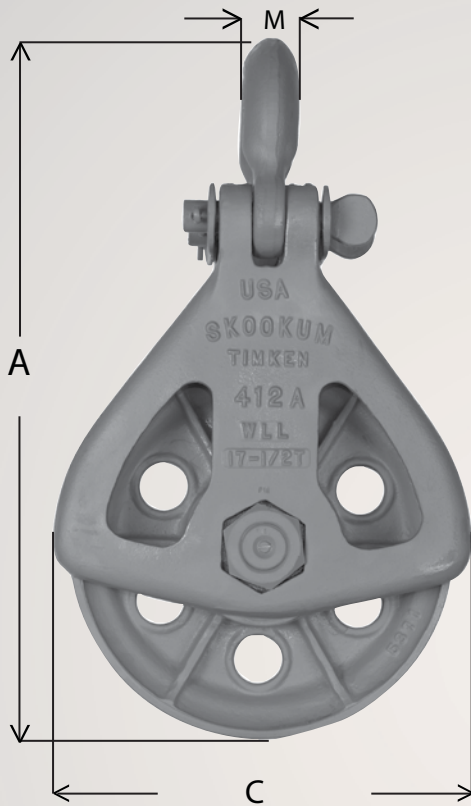

DIMENSIONS (IN)

HEIGHT	THICK-NESS	WIDTH	THROAT BOTTOM	INSIDE THROAT WIDTH	INSIDE YOKE WIDTH	YOKE WIDTH ABOVE	YOKE WIDTH BELOW	THROAT HEIGHT BELOW	THROAT HEIGHT ABOVE	YOKE BAR TOP HEIGHT	YOKE BAR WIDTH
A	B	C	D	E	NOT SHOWN	G	NOT SHOWN	J	K	L	M
HALF SIDED BLOCK											
18.50	5.50	11.00	1.75	2.75	1.75	2.75	2.75	4.50	2.50	1.50	1.25
21.00	6.25	12.50	2.00	3.00	2.38	3.00	3.00	4.75	2.50	1.75	1.63
23.00	6.25	15.00	2.00	3.00	3.38	3.00	3.00	4.75	2.50	1.75	1.63
25.00	6.25	17.00	2.00	3.00	2.38	3.00	3.00	4.75	2.50	1.75	1.63
27.00	6.25	19.00	2.00	3.00	2.38	3.00	3.00	4.75	2.50	1.75	1.63
FULL SIDED BLOCK											
25.00	6.25	15.00	2.00	3.00	2.38	3.00	3.00	4.75	2.50	1.75	1.63
27.00	6.25	17.00	2.00	3.00	2.38	3.00	3.00	4.75	2.50	1.75	1.63

Please contact us for any custom product or non-standard sizes.



WARNING: Misuse of rigging equipment can result in serious injury up to and including loss of life. Only competent trained professionals should use Skookum products. Thoroughly inspect all equipment before each and every use and never use damaged or worn products. Skookum disclaims any liability resulting from the misuse of its products. Please take a moment to carefully review our maintenance and warnings page for more information.

Half-Sided Blocks

8 Ton to 17.5 Ton Working Load Limit

T Series



MODEL SHOWN: T-10S

- Work hardening manganese steel sheaves maximize wire rope and sheave life
- Recessed sheave prevents wire rope from binding between sheave and block side
- Half side for light weight or full side design to maximize sheave protection
- Versatile draw pin design allows for rapid reeving and exchange of attaching style
- Rugged cast alloy steel sides for demanding environments
- ASTM B30.26 Compliant

SPECIFICATIONS

MODEL	SHEAVE DIAM	BEARING	REGULAR YOKE PART #	SWIVEL HOOK PART #	SWIVEL SHACKLE PART #	WIRE ROPE MIN	WIRE ROPE MAX	WLL (TONS)	REGULAR YOKE WEIGHT	SWIVEL HOOK WEIGHT	SWIVEL SHACKLE WEIGHT	SHEAVE #	DRAW PIN
T-8	8"	TRB	557903	557901	557902	1/2	5/8	8.00	32.00	36.00	37.25	539103	551420
T-10S	10"	TRB	558003	558001	558002	5/8	3/4	8.00	52.00	56.00	57.25	539903	551420
1010	10"	TRB	553703	—	553702	7/8	1	17.50	75.00	—	87.00	537903	555501
510	10"	BB	565003	—	565002	7/8	1	17.50	70.00	—	82.00	574301	555501
512	12"	BB	565103	—	565102	7/8	1	17.50	80.00	—	97.95	574501	555501

- Please specify Part Number, Sheave Size, Working Load Limit (WLL), Bearing Style and Attaching Style when ordering.
- Ultimate load for swivel attachments is four times the WLL.
- Ultimate load for yoke attachments is five times WLL.
- Ton equals 2,000 lbs.

WARNING: Misuse of rigging equipment can result in serious injury up to and including loss of life. Only competent trained professionals should use Skookum products. Thoroughly inspect all equipment before each and every use and never use damaged or worn products. Skookum disclaims any liability resulting from the misuse of its products. Please take a moment to carefully review our maintenance and warnings page for more information.

Half-Sided Blocks

8 Ton to 17.5 Ton Working Load Limit

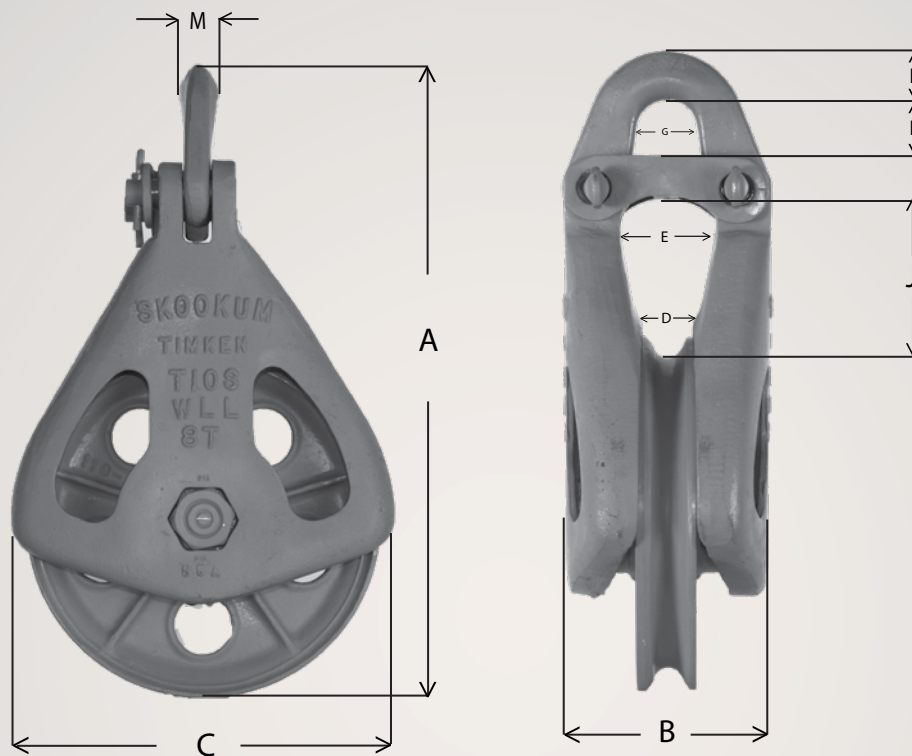

DIMENSIONS (IN)

HEIGHT	THICKNESS	WIDTH	THROAT BOTTOM	INSIDE THROAT WIDTH	INSIDE YOKE WIDTH	YOKE WIDTH ABOVE	YOKE WIDTH BELOW	THROAT HEIGHT BELOW	THROAT HEIGHT ABOVE	YOKE BAR HEIGHT	YOKE BAR WIDTH
A	B	C	D	E	NOT SHOWN	G	NOT SHOWN	J	K	L	M
16.00	5.50	8.75	1.00	2.00	1.63	1.38	2.00	4.25	2.50	1.38	1.31
18.00	5.50	10.75	1.38	2.25	1.63	1.63	2.25	4.25	2.50	1.50	1.31
19.00	6.25	11.00	2.00	2.50	2.75	2.75	2.50	2.00	2.50	2.00	1.75
19.00	6.25	11.00	2.00	2.50	2.75	2.75	2.50	3.50	2.50	2.00	1.88
22.00	6.25	13.00	2.00	2.50	2.75	2.75	2.50	3.50	2.75	2.00	1.88

Please contact us for any custom product or non-standard sizes.



WARNING: Misuse of rigging equipment can result in serious injury up to and including loss of life. Only competent trained professionals should use Skookum products. Thoroughly inspect all equipment before each and every use and never use damaged or worn products. Skookum disclaims any liability resulting from the misuse of its products. Please take a moment to carefully review our maintenance and warnings page for more information.

Half-Sided and Full-Sided Blocks 21.5 Ton to 30 Ton Working Load Limit

2200 Series



MODEL SHOWN: 2210A

- Work hardening manganese steel sheaves maximize wire rope and sheave life
- Recessed sheave prevents wire rope from binding between sheave and block side
- Half side for light weight or full side design to maximize sheave protection
- Versatile draw pin design allows for rapid reeving and exchange of attaching style
- Rugged cast alloy steel sides for demanding environments
- ASTM B30.26 Compliant

SPECIFICATIONS

MODEL	SHEAVE DIAM	BEARING	REGULAR YOKE PART #	SWIVEL SHACKLE PART #	WIRE ROPE MIN	WIRE ROPE MAX	WLL (TONS)	REGULAR YOKE WEIGHT	SWIVEL SHACKLE WEIGHT	SHEAVE #	DRAW PIN
HALF SIDED BLOCK											
2210A	10"	TRB	555003	555002	7/8	1	21.50	83.00	102.00	536503	555501
2212	12"	TRB	558603	558602	1 1/8	1 1/4	22.00	111.00	129.35	588703	555501
2214	14"	TRB	558703	558702	1 1/8	1 1/4	22.00	130.00	148.35	536103	555501
2216B	16"	TRB	558853	558852	1 1/8	1 1/4	25.00	150.00	167.80	535103	551455
2220	20"	TRB	715003	715002	1	1 1/8	27.50	157.00	176.00	711102	555501
2222	22"	TRB	711603	711602	1 1/8	1 1/4	29.00	223.00	241.35	540903	620801
FULL SIDED BLOCK											
2216HD	16"	TRB	558804	—	1	1 1/8	30.00	235.00	—	535105	621901
2218HD	18"	TRB	558904	—	1 3/8	--	30.00	275.00	—	535303	621901

- Please specify Part Number, Sheave Size, Working Load Limit (WLL), Bearing Style and Attaching Style when ordering.
- Ultimate load for swivel attachments is four times the WLL.
- Ultimate load for yoke attachments is five times WLL.
- Ton equals 2,000 lbs.

WARNING: Misuse of rigging equipment can result in serious injury up to and including loss of life. Only competent trained professionals should use Skookum products. Thoroughly inspect all equipment before each and every use and never use damaged or worn products. Skookum disclaims any liability resulting from the misuse of its products. Please take a moment to carefully review our maintenance and warnings page for more information.

Half-Sided and Full-Sided Blocks

21.5 Ton to 30 Ton Working Load Limit

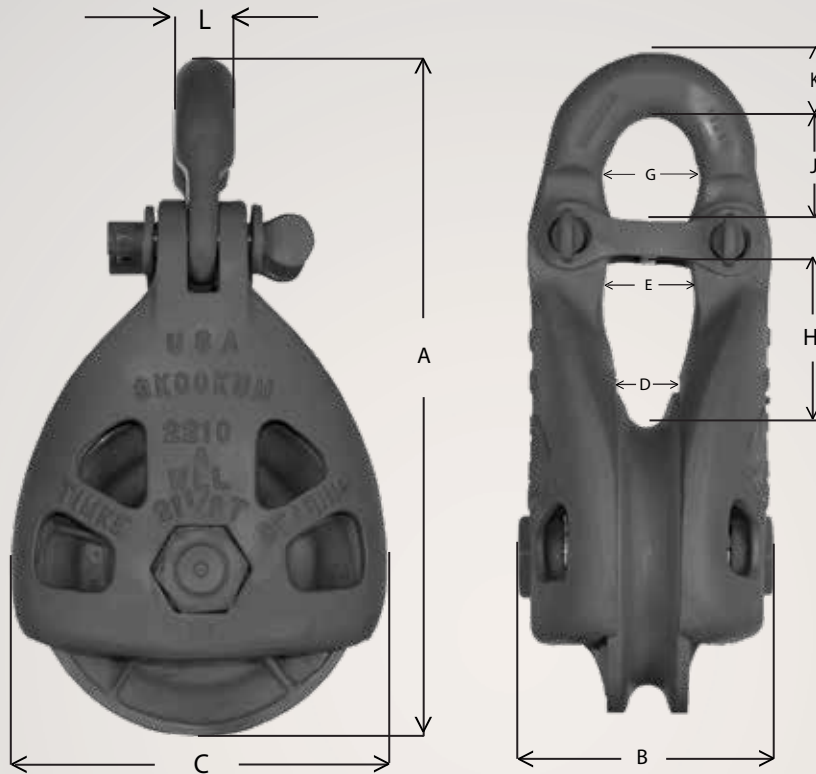

DIMENSIONS (IN)

HEIGHT	THICK-NESS	WIDTH	THROAT BOTTOM	INSIDE THROAT WIDTH	YOKE WIDTH BELOW LINEGUARD	YOKE WIDTH ABOVE LINEGUARD	THROAT HEIGHT BELOW LINEGUARD	THROAT HEIGHT ABOVE LINEGUARD	YOKE BAR HEIGHT	YOKE BAR WIDTH	SHACKLE HEIGHT
A	B	C	D	E	NOT SHOWN	G	H	J	K	L	NOT SHOWN
HALF SIDED BLOCKS											
18.00	7.00	11.00	2.00	2.75	2.75	2.75	4.25	2.25	1.75	2.00	11.50
22.00	7.50	13.00	2.00	2.75	2.75	3.00	4.50	2.50	1.75	2.00	11.50
25.00	7.50	15.00	2.00	2.75	2.75	3.00	4.75	2.50	1.75	2.00	11.50
26.50	8.00	16.63	2.13	3.00	3.00	3.00	4.00	2.25	1.75	2.00	12.00
29.75	8.00	20.75	2.13	3.00	2.13	2.50	5.13	2.75	1.75	2.00	11.50
33.38	8.00	23.00	2.13	3.13	2.13	3.38	5.25	4.25	2.13	2.38	15.00
FULL SIDED BLOCKS											
29.00	9.00	17.00	2.25	3.50	3.50	4.00	5.25	4.00	2.14	2.38	15.00
31.00	9.00	19.00	2.25	3.50	2.25	4.00	5.25	4.00	2.13	2.38	15.00

Please contact us for any custom product or non-standard sizes.



WARNING: Misuse of rigging equipment can result in serious injury up to and including loss of life. Only competent trained professionals should use Skookum products. Thoroughly inspect all equipment before each and every use and never use damaged or worn products. Skookum disclaims any liability resulting from the misuse of its products. Please take a moment to carefully review our maintenance and warnings page for more information.

Full-Sided Blocks 13 Ton to 75 Ton Working Load Limit

300/2000/2600 Series



MODEL SHOWN: BML12

- Work hardening manganese steel sheaves maximize wire rope and sheave life
- Recessed sheave prevents wire rope from binding between sheave and block side
- Full sided block maximizes sheave protection and strength
- Versatile draw pin design allows for rapid reeving and exchange of attaching style
- Rugged cast alloy steel sides for demanding environments
- ASTM B30.26 Compliant

SPECIFICATIONS

MODEL #	SHEAVE DIAMETER	BEARING	REGULAR YOKE PART #	WIRE ROPE MIN	WIRE ROPE MAX	WLL (TONS)	REGULAR YOKE WEIGHT	SHEAVE #	DRAW PIN
308	8"	BB	790900	7/8	1	13.00	55.00	791101	551431
310	10"	BB	791600	1 1/8	1 1/4	20.50	120.00	791801	551450
312	12"	BB	792200	1 1/4	1 3/8	23.00	145.00	792401	551450
2014	14"	BB	565700	1 1/2	1 5/8	36.50	250.00	541101	621102
2016	16"	BB	565800	1 1/2	1 5/8	40.50	435.00	588801	621401
BML12	12"	TRB	625000	1 1/8	1 1/4	27.50	150.00	960185	960189
2616	16"	TRB	559400	1 1/2	1 5/8	50.00	600.00	575403	102960
2624	24"	TRB	559500	1 1/2	1 5/8	75.00	850.00	262405	102960

- Please specify Part Number, Sheave Size, Working Load Limit (WLL), Bearing Style and Attaching Style when ordering.
- Ultimate load for swivel attachments is four times the WLL.
- Ultimate load for yoke attachments is five times WLL.
- Ton equals 2,000 lbs.

WARNING: Misuse of rigging equipment can result in serious injury up to and including loss of life. Only competent trained professionals should use Skookum products. Thoroughly inspect all equipment before each and every use and never use damaged or worn products. Skookum disclaims any liability resulting from the misuse of its products. Please take a moment to carefully review our maintenance and warnings page for more information.

Full-Sided Blocks

13 Ton to 75 Ton Working Load Limit

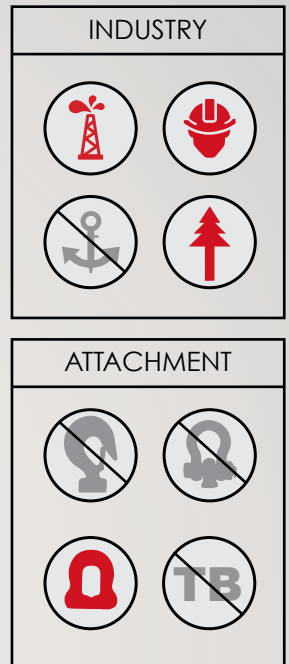
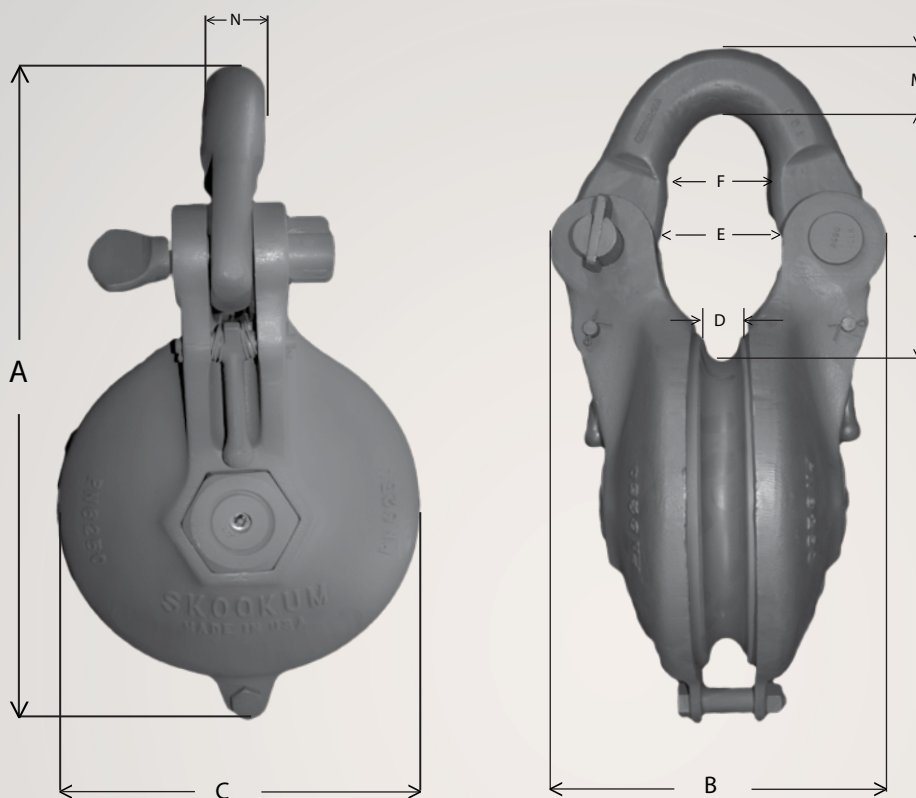

DIMENSIONS (IN)

HEIGHT	THICK NESS	WIDTH	THROAT BOTTOM WIDTH	INSIDE THROAT WIDTH	INSIDE YOKE WIDTH	YOKE WIDTH BELOW LINEGUARD	YOKE WIDTH ABOVE LINEGUARD	THROAT HEIGHT	THROAT HEIGHT BELOW LINEGUARD	THROAT HEIGHT ABOVE LINEGUARD	YOKE BAR HEIGHT	YOKE BAR WIDTH	EYE INSIDE HEIGHT	EYE INSIDE WIDTH
A	B	C	D	E	F	NOT SHOWN	NOT SHOWN	J	NOT SHOWN	NOT SHOWN	M	N	NOT SHOWN	NOT SHOWN
18.50	7.00	8.13	1.75	2.75	2.50	—	—	7.50	—	—	1.85	1.38	—	—
22.50	9.00	11.00	1.75	2.75	3.50	—	—	8.50	—	—	2.25	2.30	—	—
24.50	9.00	13.00	1.75	2.75	3.50	—	—	8.75	—	—	2.25	2.30	—	—
31.00	11.50	15.00	2.50	3.00	3.00	3.25	3.00	NA	5.75	4.00	2.45	2.45	—	—
35.00	12.00	17.00	2.50	3.50	5.00	4.75	4.50	NA	6.75	5.25	2.55	2.55	—	—
25.00	11.75	13.00	1.75	4.50	4.00	—	—	9.00	—	—	2.75	2.15	—	—
37.00	12.50	17.50	3.00	4.00	7.75	4.50	5.00	15.00	6.80	6.00	2.75	2.92	—	—
46.00	14.00	29.00	3.00	5.25	8.00	4.50	5.00	15.50	10.80	6.00	2.75	2.92	6.00	3.75

Please contact us for any custom product or non-standard sizes.



WARNING: Misuse of rigging equipment can result in serious injury up to and including loss of life. Only competent trained professionals should use Skookum products. Thoroughly inspect all equipment before each and every use and never use damaged or worn products. Skookum disclaims any liability resulting from the misuse of its products. Please take a moment to carefully review our maintenance and warnings page for more information.

Aluminum Utili-Sheave Blocks 3 Ton Working Load Limit

SK-4 Light Weight Series



MODEL SHOWN: SK-4

- Work hardening manganese steel sheaves maximize wire rope and sheave life or light weight aluminum sheaves
- Multi-use wide throat and Utili-Sheave for passing a variety of line, connecting links and terminations
- Recessed sheave prevents wire rope from binding between sheave and block side
- Full sided block maximizes sheave protection and strength
- Versatile draw pin design allows for rapid reeving and exchange of attaching style
- Rugged cast aluminum alloy sides minimize weight without sacrificing performance
- ASTM B30.26 Compliant

SPECIFICATIONS

MODEL #	SHEAVE DIAM	BEARING	REGULAR YOKE PART #	SWIVEL HOOK PART #	SWIVEL SHACKLE/EYE PART #	WIRE ROPE MIN	WLL (TONS)	REGULAR YOKE WEIGHT	SWIVEL HOOK WEIGHT	SWIVEL SHACKLE WEIGHT
SK-4	4"	BB	191114	191214	191314	3/8	3.00	6.00	8.00	7.00
SK-4M	4"	BB	191114M	191214M	191314M	3/8	3.00	7.50	9.50	8.50
SK-4R	4"	SRB	191104	191204	191304	3/8	3.00	6.00	8.00	7.00
SK-4RM	4"	SRB	191104M	191204M	191304M	3/8	3.00	7.50	9.50	8.50

- Please specify Part Number, Sheave Size, Working Load Limit (WLL), Bearing Style and Attaching Style when ordering.
- Ultimate load for swivel attachments is four times the WLL.
- Ultimate load for yoke attachments is five times WLL.
- Ton equals 2,000 lbs.

WARNING: Misuse of rigging equipment can result in serious injury up to and including loss of life. Only competent trained professionals should use Skookum products. Thoroughly inspect all equipment before each and every use and never use damaged or worn products. Skookum disclaims any liability resulting from the misuse of its products. Please take a moment to carefully review our maintenance and warnings page for more information.

Aluminum Utili-Sheave Blocks 3 Ton Working Load Limit

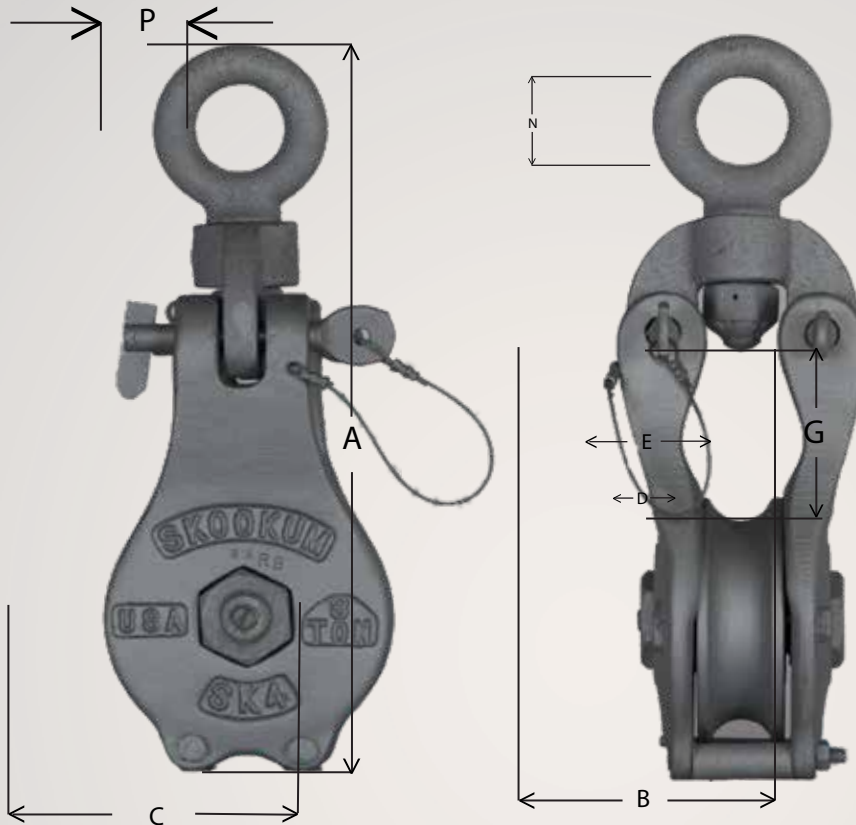

DIMENSIONS (IN)

HEIGHT	THICK-NESS	WIDTH	THROAT BOTTOM	INSIDE THROAT WIDTH	INSIDE YOKE WIDTH	THROAT HEIGHT	YOKE BAR HEIGHT	YOKE BAR WIDTH	HOOK OPEN	HOOK HEIGHT	HOOK TOP THICK	EYE INSIDE HEIGHT	EYE INSIDE WIDTH
A	B	C	D	E	NOT SHOWN	G	NOT SHOWN	NOT SHOWN	NOT SHOWN	NOT SHOWN	NOT SHOWN	N	P
9.63	3.25	4.63	1.31	2.00	1.13	4.50	0.91	0.78	1.11	3.25	1.00	1.50	1.50
9.63	3.25	4.63	1.31	2.00	1.13	4.50	0.91	0.78	1.11	3.25	1.00	1.50	1.50
9.63	3.25	4.63	1.31	2.00	1.31	4.50	0.91	0.78	1.11	3.25	1.00	1.50	1.50
9.63	3.25	4.63	1.31	2.00	1.31	4.50	0.91	0.78	1.11	3.25	1.00	1.50	1.50

Please contact us for any custom product or non-standard sizes.



WARNING: Misuse of rigging equipment can result in serious injury up to and including loss of life. Only competent trained professionals should use Skookum products. Thoroughly inspect all equipment before each and every use and never use damaged or worn products. Skookum disclaims any liability resulting from the misuse of its products. Please take a moment to carefully review our maintenance and warnings page for more information.

Half-Sided Blocks

6.25 Ton to 15 Ton Working Load Limit

Rope Master Half Side Series



MODEL SHOWN: 108RA

- Work hardening manganese steel sheaves maximize wire rope and sheave life
- Alloy steel sheaves are used on lightweight models 513A and 515A
- Equipped with tapered roller bearings for long life in higher line speed applications
- Recessed sheave prevents wire rope from binding between sheave and block side
- Half side design for strength with minimized weight
- Versatile draw pin design allows for rapid reeving and exchange of attaching style
- Rugged cast alloy steel sides for demanding environments
- ASTM B30.26 Compliant

SPECIFICATIONS

MODEL #	SHEAVE DIAMETER	BEARING	REGULAR YOKE PART #	SWIVEL HOOK PART #	SWIVEL SHACKLE/EYE PART #	WIRE ROPE MIN	WIRE ROPE MAX	WLL (TONS)	REGULAR YOKE WEIGHT	SWIVEL HOOK WEIGHT	SWIVEL SHACKLE/EYE WEIGHT	SHEAVE #	DRAW PIN
106	6"	TRB	205600	205602	205601	3/8	1/2	6.25	21.00	24.25	24.25	222003	551410
108RA	8"	TRB	205800A	205801A	205802A	1/2	5/8	6.25	28.70	34.70	35.00	223811	551413
110RA	10"	TRB	206000A	206001A	206002A	1/2	5/8	8.00	38.55	46.00	47.00	224011	551464
112RA	12"	TRB	206200A	206201A	206202A	1/2	5/8	8.00	47.00	56.00	57.00	224211	551464
210TR	10"	TRB	206400	206401	206402	3/4	7/8	15.00	59.00	68.00	69.00	224603	551465
212TR	12"	TRB	206800	206801	206802	3/4	7/8	15.00	69.00	78.00	79.00	224803	551465
513A	13"	TRB	210001	—	210002	3/4	7/8	15.00	63.00	—	73.00	226404	551465
515A	15"	TRB	210201	—	210202	7/8	1.00	15.00	73.00	—	83.00	226805* 226705M	551465

- Optional manganese steel sheave is part number 226705M. 226805 is standard alloy steel sheave.
- Please specify Part Number, Sheave Size, Working Load Limit (WLL), Bearing Style and Attaching Style when ordering.
- Ultimate load for swivel attachments is four times the WLL.
- Ultimate load for yoke attachments is five times WLL.
- Ton equals 2,000 lbs.

WARNING: Misuse of rigging equipment can result in serious injury up to and including loss of life. Only competent trained professionals should use Skookum products. Thoroughly inspect all equipment before each and every use and never use damaged or worn products. Skookum disclaims any liability resulting from the misuse of its products. Please take a moment to carefully review our maintenance and warnings page for more information.

Half-Sided Blocks

6.25 Ton to 15 Ton Working Load Limit

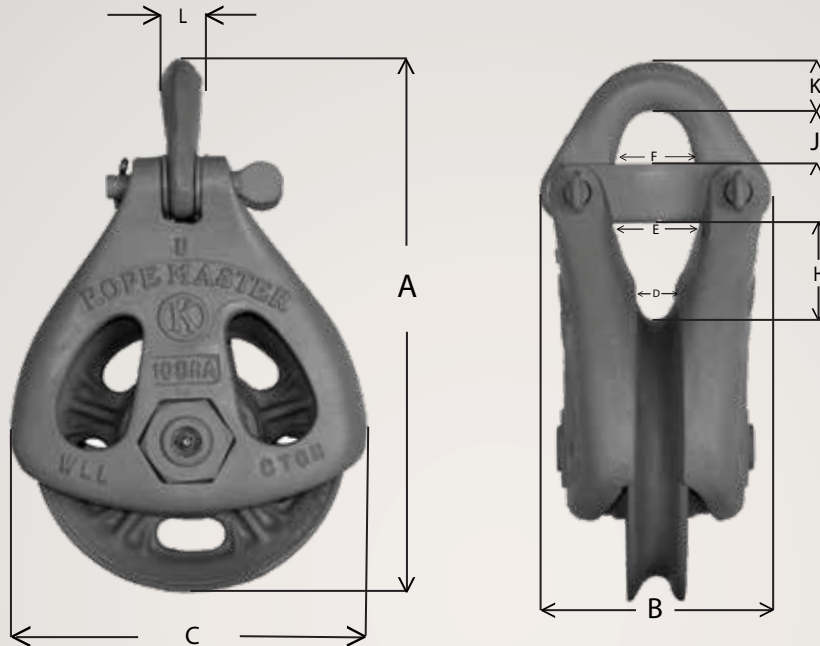

DIMENSIONS (IN)

HEIGHT	THICK	WIDTH	THROAT BTM	INSIDE THROAT WIDTH	YOKE WIDTH ABOVE	THROAT HEIGHT	THROAT HEIGHT BELOW	THROAT HEIGHT ABOVE	YOKE BAR HEIGHT	YOKE BAR WIDTH	HOOK OPEN	HOOK HEIGHT	HOOK TOP THICK	HOOK TOP THICK	SHACKLE HEIGHT	EYE INSIDE HEIGHT	EYE INSIDE WIDTH
A	B	C	D	E	F	NOT SHOWN	H	J	K	L	NOT SHOWN	NOT SHOWN	NOT SHOWN	NOT SHOWN	NOT SHOWN	NOT SHOWN	NOT SHOWN
11.50	5.68	6.56	1.25	2.43	—	5.00	—	—	1.09	1.25	1.31	3.50	1.53	1.19	5.38	—	—
13.94	5.75	8.75	1.25	2.56	2.25	—	2.13	1.32	1.09	1.25	1.31	3.50	1.53	1.19	5.75	—	—
17.38	5.75	10.50	1.38	2.56	2.56	—	3.25	2.50	1.25	1.25	1.50	4.00	1.82	1.38	4.75	—	—
20.00	5.75	12.50	1.38	2.56	2.56	—	3.75	2.50	1.25	1.25	1.50	4.00	1.82	1.38	4.75	—	—
18.00	7.00	10.50	2.00	2.63	2.63	—	2.37	3.00	1.58	1.63	1.50	4.50	1.82	1.38	5.25	—	—
20.50	6.00	13.50	2.00	2.75	2.75	—	2.88	3.00	1.58	1.63	1.50	4.50	1.82	1.38	5.25	—	—
21.50	6.00	13.50	2.00	2.75	2.75	7.25	2.88	2.25	1.50	1.63	—	—	—	—	7.00	1.28	1.28
24.25	6.00	15.50	2.38	3.00	3.00	7.63	3.25	2.25	1.50	1.63	—	—	—	—	7.00	1.28	1.28

Please contact us for any custom product or non-standard sizes.



WARNING: Misuse of rigging equipment can result in serious injury up to and including loss of life. Only competent trained professionals should use Skookum products. Thoroughly inspect all equipment before each and every use and never use damaged or worn products. Skookum disclaims any liability resulting from the misuse of its products. Please take a moment to carefully review our maintenance and warnings page for more information.

Full-Sided Blocks

3.25 Ton to 15 Ton Working Load Limit

Rope Master Full Side Series



MODEL SHOWN: 82-S

- Work hardening manganese steel sheaves maximize wire rope and sheave life
- Equipped with tapered roller bearings for long life in higher line speed applications
- Recessed sheave prevents wire rope from binding between sheave and block side
- Full sided block maximizes sheave protection and strength
- Versatile draw pin design allows for rapid reeving and exchange of attaching style
- Rugged cast alloy steel sides for demanding environments
- ASTM B30.26 Compliant

SPECIFICATIONS

MODEL	SHEAVE DIAM	BEARING	REGULAR YOKE PART #	SWIVEL HOOK PART #	SWIVEL SHACKLE PART #	WIRE ROPE MIN	WIRE ROPE MAX	WLL (TONS)	REGULAR YOKE WEIGHT	SWIVEL HOOK WEIGHT	SWIVEL SHACKLE WEIGHT	SHEAVE #	DRAW PIN
6	6"	TRB	200200	200203	200204	3/8	1/2	3.25	20.20	22.00	22.00	220203	551413
62-S	6"	TRB	203600	203603	203604	3/8	1/2	3.75	26.00	28.65	27.00	221803	551413
82-S	8"	TRB	204800	204803	204804	3/8	1/2	3.75	33.00	34.00	34.00	222603	551413
508	8"	TRB	209800	—	—	1	1 1/8	15.00	72.00	—	—	226203	551468
EXTRA WIDE SHEAVE													
64	6"	TRB	—	204003	204004	3/8	1/2	3.75	—	30.00	30.00	223603	—

- Please specify Part Number, Sheave Size, Working Load Limit (WLL), Bearing Style and Attaching Style when ordering.
- Ultimate load for swivel attachments is four times the WLL.
- Ultimate load for yoke attachments is five times WLL.
- Ton equals 2,000 lbs.
- Model 64 has Rope Master snatch lock

WARNING: Misuse of rigging equipment can result in serious injury up to and including loss of life. Only competent trained professionals should use Skookum products. Thoroughly inspect all equipment before each and every use and never use damaged or worn products. Skookum disclaims any liability resulting from the misuse of its products. Please take a moment to carefully review our maintenance and warnings page for more information.

Full-Sided Blocks

3.25 Ton to 15 Ton Working Load Limit

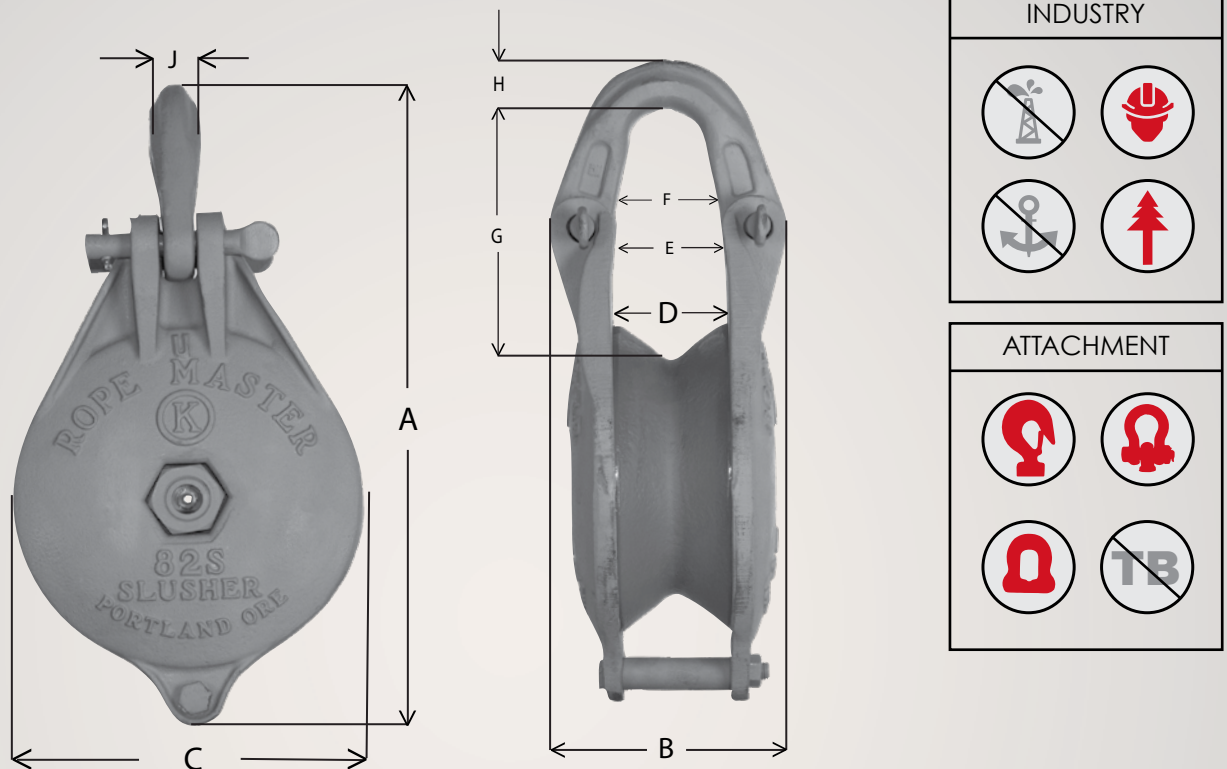

DIMENSIONS (IN)

HEIGHT	THICK-NESS	WIDTH	THROAT BOT-TOM	INSIDE THROAT WIDTH	INSIDE YOKE WIDTH	THROAT HEIGHT	YOKE BAR HEIGHT	YOKE BAR WIDTH	HOOK OPEN	HOOK HEIGHT	HOOK TOP THICK	HOOK TOP THICK	SHACKLE HEIGHT	EYE INSIDE	
A	B	C	D	E	F	G	H	J	NOT SHOWN	NOT SHOWN	NOT SHOWN	NOT SHOWN	NOT SHOWN	NOT SHOWN	
12.75	5.75	6.50	2.50	2.75	2.50	4.75	1.25	1.38	1.50	3.63	1.11	1.13	4.15	0.78	
13.75	5.75	6.75	2.75	2.75	2.50	5.00	1.25	1.38	1.50	3.63	1.11	1.13	4.15	0.78	
16.50	5.50	8.50	2.75	2.75	2.50	5.25	1.25	1.38	1.50	3.63	1.11	1.13	4.15	0.78	
15.00	11.00	9.50	4.00	4.00	5.25	6.50	2.00	2.00	—	—	—	—	—	—	
EXTRA WIDE SHEAVE															
16.75	4.8125	10.25	1.00	2.25	—	2.00	—	—	1.50	3.625	1.11	1.13	4.15	0.78	

Please contact us for any custom product or non-standard sizes.



WARNING: Misuse of rigging equipment can result in serious injury up to and including loss of life. Only competent trained professionals should use Skookum products. Thoroughly inspect all equipment before each and every use and never use damaged or worn products. Skookum disclaims any liability resulting from the misuse of its products. Please take a moment to carefully review our maintenance and warnings page for more information.

Trawl Blocks

10 Ton to 90 Ton Working Load Limit

TB-Series



MODEL SHOWN: TB16W

- Work hardening manganese steel sheaves maximize wire rope and sheave life
- Equipped with tapered roller bearings for long life in higher line speed applications
- Swivel eyes designed with thrust bearings for ease of rotation
- Galvanized for a durable and corrosion resistant finish

SPECIFICATIONS

MODEL #	SHEAVE DIAMETER	BEARING	SWIVEL SHACKLE/EYE PART #	WLL (TONS)	SWIVEL SHACKLE WEIGHT	SHEAVE #
TB10W	10"	TRB	560110	10.00	125.00	108526
TB16W	16"	TRB	560100	25.00	370.00	101983
TB24W	24"	TRB	560150	50.00	700.00	112403
TB30W	30"	TRB	560175	90.00	1250.00	113003

- Please specify Part Number, Sheave Size and Working Load Limit (WLL).
- Ultimate load four times WLL.
- Ton equals 2,000 lbs.

 **WARNING:** Misuse of rigging equipment can result in serious injury up to and including loss of life. Only competent trained professionals should use Skookum products. Thoroughly inspect all equipment before each and every use and never use damaged or worn products. Skookum disclaims any liability resulting from the misuse of its products. Please take a moment to carefully review our maintenance and warnings page for more information.

Trawl Blocks

10 Ton to 90 Ton Working Load Limit

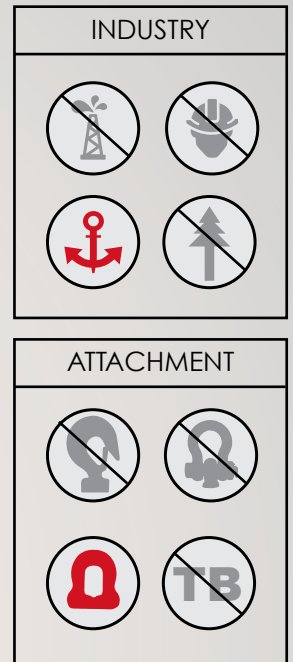
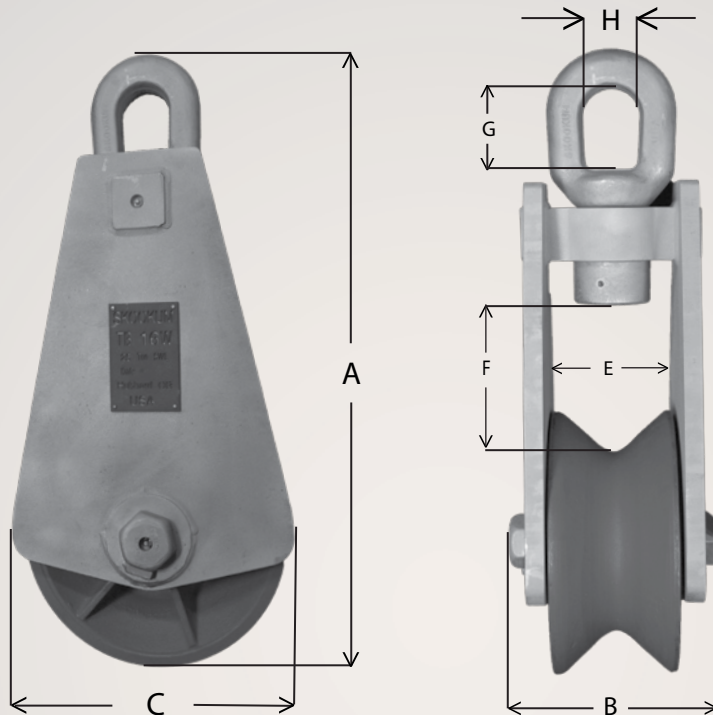

DIMENSIONS (IN)

HEIGHT	THICK-NESS	WIDTH	THROAT WIDTH	THROAT HEIGHT	EYE INSIDE HEIGHT	EYE INSIDE WIDTH
A	B	C	E	F	G	H
25.00	8.75	11.00	5.38	5.00	3.75	2.50
39.00	12.00	17.00	7.38	9.00	4.50	3.00
43.00	12.00	25.00	7.38	7.38	4.50	3.00
55.00	16.00	31.00	7.38	6.00	3.38	3.38

Please contact us for any custom product or non-standard sizes.



WARNING: Misuse of rigging equipment can result in serious injury up to and including loss of life. Only competent trained professionals should use Skookum products. Thoroughly inspect all equipment before each and every use and never use damaged or worn products. Skookum disclaims any liability resulting from the misuse of its products. Please take a moment to carefully review our maintenance and warnings page for more information.

Trawl Half-Side Blocks 5 Ton to 30 Ton Working Load Limit

BCM Series



MODEL SHOWN: BCM16

- Work hardening manganese steel sheaves maximize wire rope and sheave life
- Equipped with tapered roller bearings for long life in higher line speed applications
- Enclosed swivel eye to prevent net entanglement
- Recessed sheave prevents wire rope from binding between sheave and block side
- Galvanized for a durable corrosion resistant finish
- Half side for light weight or full side design for maximized sheave protection
- Rugged cast alloy steel sides for demanding environments

SPECIFICATIONS

MODEL #	SHEAVE DIAMETER	BEARING	SWIVEL SHACKLE/EYE PART #	SWIVEL SHACKLE/EYE WEIGHT	WLL (TONS)	SHEAVE #
BCM6 ¹	6"	BB	307797	25.00	5.00	309272
BCM8	8"	RB	307800	41.00	10.00	307805
BCM12	12"	TRB	307912	79.00	10.00	308118M
BCM16	16"	TRB	308357	132.00	20.00	308597M
BCM18	18"	TRB	308369	151.00	20.00	308795M
BCM20	20"	TRB	308379	330.00	30.00	309215M

- ¹BCM6 has bronze bushed sheave
- Please specify Part Number, Sheave Size, Working Load Limit (WLL), Bearing Style and Attaching Style when ordering.
- Ultimate load four times WLL.
- Ton equals 2,000 lbs.

 **WARNING:** Misuse of rigging equipment can result in serious injury up to and including loss of life. Only competent trained professionals should use Skookum products. Thoroughly inspect all equipment before each and every use and never use damaged or worn products. Skookum disclaims any liability resulting from the misuse of its products. Please take a moment to carefully review our maintenance and warnings page for more information.

Trawl Half-Side Blocks

5 Ton to 30 Ton Working Load Limit

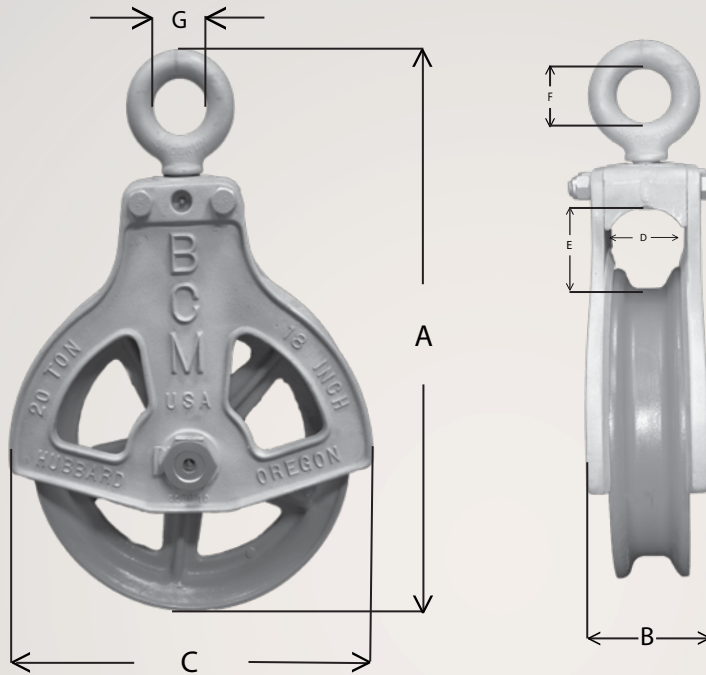

DIMENSIONS (IN)

HEIGHT	THICKNESS	WIDTH	INSIDE THROAT WIDTH	THROAT HEIGHT	EYE INSIDE HEIGHT	EYE INSIDE WIDTH
A	B	C	D	E	F	G
14.00	5.50	7.50	2.50	3.00	2.50	2.50
19.00	6.25	9.00	2.63	4.25	2.50	2.50
23.00	6.50	13.50	3.50	2.50	2.50	3.00
28.00	7.00	17.50	3.50	3.50	3.50	3.00
31.00	7.00	20.63	3.50	4.50	3.00	3.00
37.00	10.00	23.50	6.50	7.25	4.50	3.00

Please contact us for any custom product or non-standard sizes.



WARNING: Misuse of rigging equipment can result in serious injury up to and including loss of life. Only competent trained professionals should use Skookum products. Thoroughly inspect all equipment before each and every use and never use damaged or worn products. Skookum disclaims any liability resulting from the misuse of its products. Please take a moment to carefully review our maintenance and warnings page for more information.

Trawl Full-Sided Blocks 10 Ton to 30 Ton Working Load Limit

BCM Series



MODEL SHOWN: BCM18FS

- Work hardening manganese steel sheaves maximize wire rope and sheave life
- Equipped with tapered roller bearings for long life in higher line speed applications (BCM6 has bronze bushed sheave)
- Enclosed swivel eye to prevent net entanglement
- Recessed sheave prevents wire rope from binding between sheave and block side
- Galvanized for a durable corrosion resistant finish
- Half side for light weight or full side design for maximized sheave protection
- Rugged cast alloy steel sides for demanding environments

SPECIFICATIONS

MODEL #	SHEAVE DIAMETER	BEARING	SWIVEL SHACKLE/EYE PART #	SWIVEL SHACKLE/EYE WEIGHT	WLL (TONS)	SHEAVE #
BCM12FS	12"	TRB	307912T	87.00	10.00	308118M
BCM16FS	16"	TRB	308357T	158.00	20.00	308597M
BCM18FS 20T	18"	TRB	308369T	205.00	20.00	308795M
BCM18FS 25T	18"	TRB	308870T	315.00	25.00	388005M
BCM20FS	20"	TRB	308379T	370.00	30.00	309215M
BCM16 EWS	16"	TRB	308357W	174.00	20.00	308591WM
BCM16FS EWS	16"	TRB	308357TW	200.00	20.00	308591WM

- Please specify Part Number, Sheave Size, Working Load Limit (WLL), Bearing Style and Attaching Style when ordering.
- Ultimate load four times WLL.
- Ton equals 2,000 lbs.

WARNING: Misuse of rigging equipment can result in serious injury up to and including loss of life. Only competent trained professionals should use Skookum products. Thoroughly inspect all equipment before each and every use and never use damaged or worn products. Skookum disclaims any liability resulting from the misuse of its products. Please take a moment to carefully review our maintenance and warnings page for more information.

Trawl Full-Sided Blocks

10 Ton to 30 Ton Working Load Limit

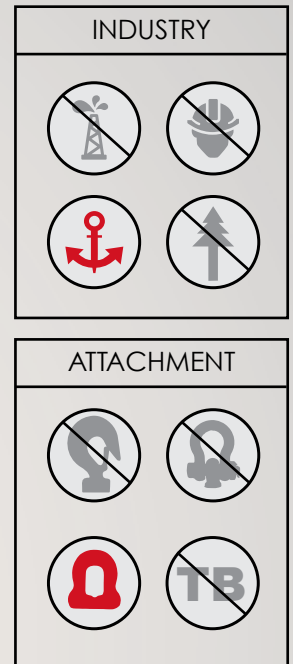
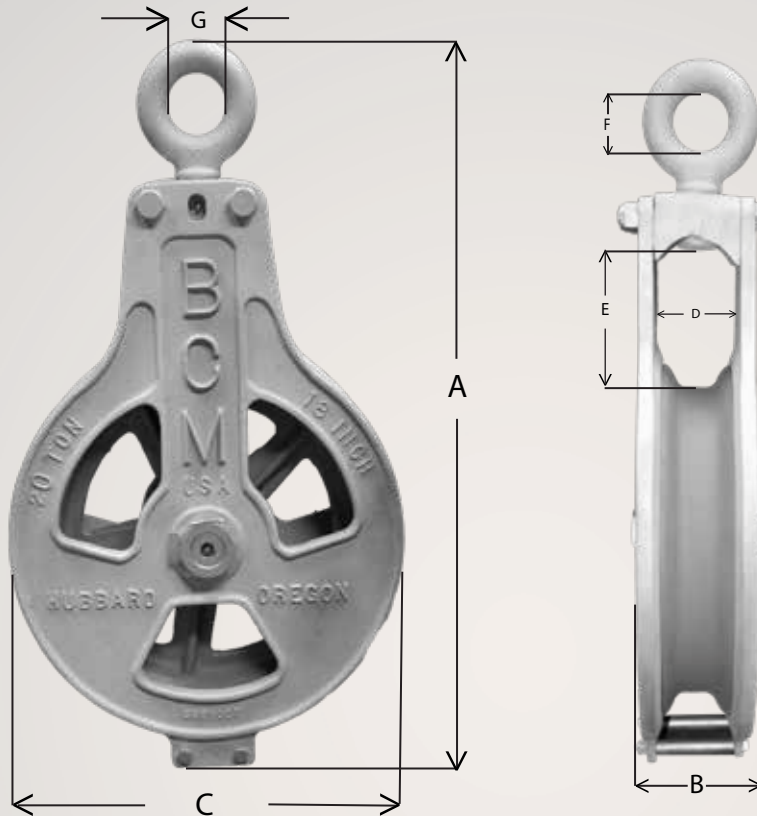

DIMENSIONS (IN)

HEIGHT	THICK-NESS	WIDTH	INSIDE THROAT WIDTH	THROAT HEIGHT	EYE INSIDE HEIGHT	EYE INSIDE WIDTH
A	B	C	D	E	F	G
26.00	6.50	13.50	3.50	4.50	2.50	2.50
32.00	7.50	17.50	2.50	3.00	3.00	3.00
36.00	7.50	20.50	3.50	7.50	3.00	3.00
39.00	9.25	20.50	5.50	7.00	4.50	3.00
41.00	10.00	23.50	6.50	7.50	4.50	3.00
28.00	9.00	17.50	5.00	—	3.00	3.00
32.00	9.00	17.50	5.00	—	3.00	3.00

Please contact us for any custom product or non-standard sizes.



WARNING: Misuse of rigging equipment can result in serious injury up to and including loss of life. Only competent trained professionals should use Skookum products. Thoroughly inspect all equipment before each and every use and never use damaged or worn products. Skookum disclaims any liability resulting from the misuse of its products. Please take a moment to carefully review our maintenance and warnings page for more information.

Wide Try Net & Outrigger Blocks 5 Ton to 10 Ton Working Load Limit

Wide Try Net Series



MODEL SHOWN: BCM FB

- Multi-use wide throat and Utili-Sheave for passing a variety of line and nets
- Enclosed swivel eye to prevent net entanglement
- Recessed sheave prevents wire rope from binding between sheave and block side
- Full sided block maximizes sheave protection and strength
- Galvanized for a durable and corrosion resistant finish

SPECIFICATIONS

MODEL #	SHEAVE DIAMETER	BEARING	SWIVEL SHACKLE/EYE PART #	WLL (TONS)	WEIGHT	SHEAVE #
WIDE TRY NET BLOCK						
BCM FB	6"	BB	307700	5.00	16.70	309272
BCM SFB	6"	BB	308800	10.00	25.00	307781

- Please specify Part Number, Sheave Size, Working Load Limit (WLL), Bearing Style and Attaching Style when ordering.
- Ultimate load four times WLL.
- Ton equals 2,000 lbs.

 **WARNING:** Misuse of rigging equipment can result in serious injury up to and including loss of life. Only competent trained professionals should use Skookum products. Thoroughly inspect all equipment before each and every use and never use damaged or worn products. Skookum disclaims any liability resulting from the misuse of its products. Please take a moment to carefully review our maintenance and warnings page for more information.

Wide Try Net & Outrigger Blocks

5 Ton to 10 Ton Working Load Limit

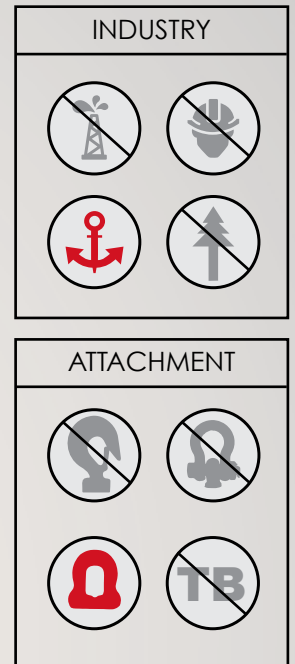
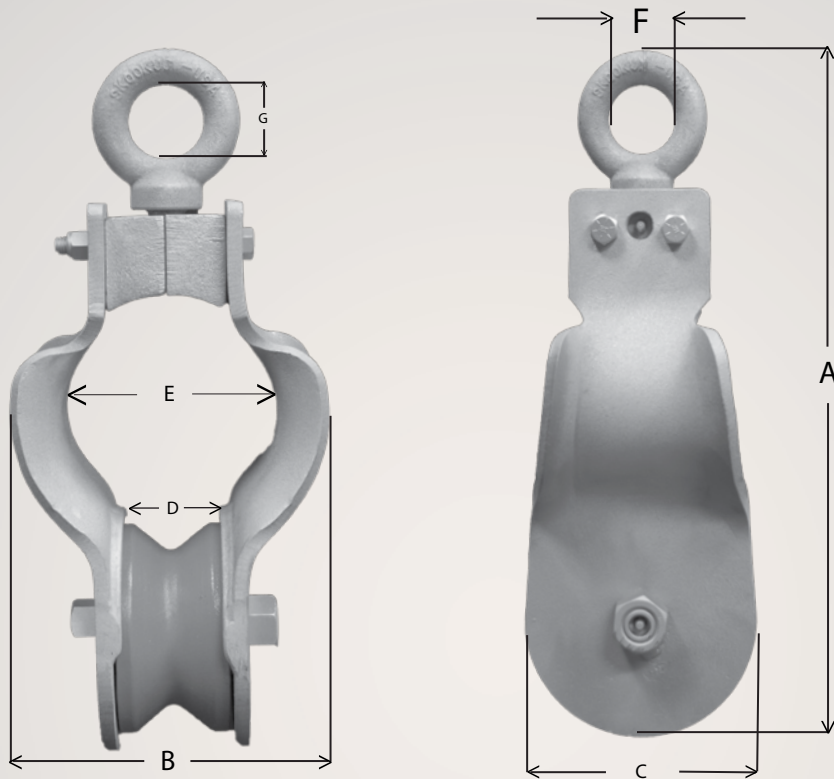

DIMENSIONS (IN)

HEIGHT	THICKNESS	WIDTH	INSIDE THROAT BOTTOM	INSIDE THROAT WIDTH	EYE INSIDE WIDTH	EYE INSIDE HEIGHT
A	B	C	D	E	F	G
WIDE TRY NET BLOCK						
19.00	8.00	6.50	2.25	5.75	2.50	2.50
21.00	9.50	6.50	3.68	6.75	3.00	3.00

Please contact us for any custom product or non-standard sizes.



WARNING: Misuse of rigging equipment can result in serious injury up to and including loss of life. Only competent trained professionals should use Skookum products. Thoroughly inspect all equipment before each and every use and never use damaged or worn products. Skookum disclaims any liability resulting from the misuse of its products. Please take a moment to carefully review our maintenance and warnings page for more information.

Wide Try Net & Outrigger Blocks 3 Ton Working Load Limit



MODEL SHOWN: BCM OR 6"

Outrigger Series

- Full sided block maximizes sheave protection and strength
- Galvanized for a durable corrosion resistant finish

SPECIFICATIONS

MODEL #	SHEAVE DIAMETER	BEARING	PART #	WIRE ROPE MIN	WIRE ROPE MAX	WLL (TONS)	WEIGHT	SHEAVE #
OUTRIGGER BLOCK								
BCM OR 6" 1 sheave	6"	BB	305100	7/16	1/2	3.00	16.70	304701
BCM OR 6" 2 sheave	6"	BB	305000	7/16	1/2	3.00	25.00	304701

- Please specify Part Number, Sheave Size, Working Load Limit and Bearing Style.
- Ultimate load four times WLL.
- Ton equals 2,000 lbs.

 **WARNING:** Misuse of rigging equipment can result in serious injury up to and including loss of life. Only competent trained professionals should use Skookum products. Thoroughly inspect all equipment before each and every use and never use damaged or worn products. Skookum disclaims any liability resulting from the misuse of its products. Please take a moment to carefully review our maintenance and warnings page for more information.

Wide Try Net & Outrigger Blocks 3 Ton Working Load Limit

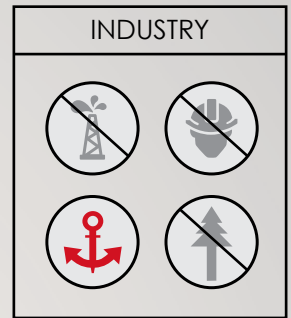
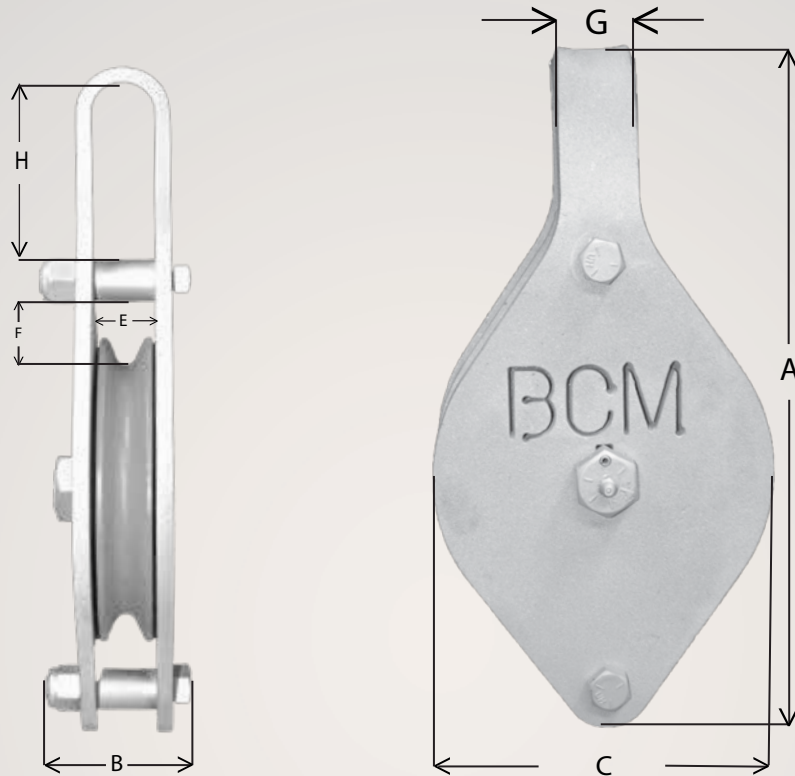

DIMENSIONS (IN)

HEIGHT	THICKNESS	WIDTH	INSIDE THROAT WIDTH	THROAT HEIGHT	EYE INSIDE WIDTH	EYE INSIDE HEIGHT
A	B	C	E	F	G	H
OUTRIGGER BLOCK						
15.27	4.50	5.00	1.87	1.50	1.10	1.10
15.27	6.62	5.00	1.87	1.50	1.10	1.10

Please contact us for any custom product or non-standard sizes.



WARNING: Misuse of rigging equipment can result in serious injury up to and including loss of life. Only competent trained professionals should use Skookum products. Thoroughly inspect all equipment before each and every use and never use damaged or worn products. Skookum disclaims any liability resulting from the misuse of its products. Please take a moment to carefully review our maintenance and warnings page for more information.

Sheave Products



Sheaves Products Manganese & Cast Steel

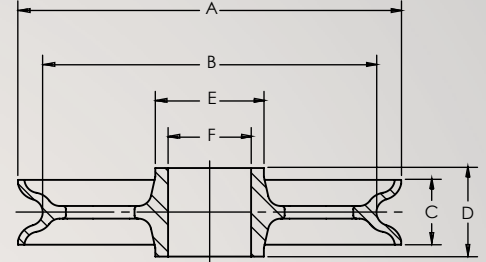

SPECIFICATIONS

SHEAVE #	ROPE SIZE (INCHES)	APPROX. WEIGHT (LBS)	MATERIAL
A-4	3/8 - 1/2	2.00	Manganese
A-6	3/8 - 1/2	6.00	Manganese
T-6	1/2 - 9/16	6.00	Manganese
106R	1/2	5.00	Manganese
706	1/2	8.00	Manganese
6171	3/8 - 1/2	5.00	Cast Steel
F-7	1/2 - 9/16	8.00	Manganese
A-8	1/2 - 5/8	7.00	Manganese
T-8	5/8	7.00	Manganese
108R	5/8	9.00	Manganese
F-8	5/8 - 3/4	13.00	Manganese
808	5/8 - 3/4	10.00	Manganese
308	7/8 - 1	9.00	Manganese
80	1 1/8 - 1 1/4	20.00	Manganese
6172	1/2 - 5/8	11.00	Cast Steel
T-10S	5/8 - 3/4	12.00	Manganese
BP-100	5/8 - 3/4	9.00	Manganese
R-10	5/8 - 3/4	16.00	Manganese
A-10	5/8 - 3/4	9.00	Manganese
410	5/8 - 3/4	12.00	Manganese
1010	7/8 - 1	17.00	Manganese
2210	7/8 - 1	16.00	Manganese
510	7/8 - 1	20.00	Manganese
310	1 1/4	20.00	Manganese
104406	3/4	22.00	Cast Steel
109080	5/8 - 3/4	18.00	Cast Steel
6173	5/8 - 3/4	16.00	Cast Steel

DIMENSIONS (IN)

A OUTSIDE DIAMETER	B TREAD DIAMETER	C RIM WIDTH	D HUB WIDTH	E HUB DIAMETER	F BORE MIN-MAX
4.00	2.88	1.38	1.50	2.13	1.75
6.00	4.88	1.13	2.25	2.44	1.88
6.00	5.00	1.38	3.25	3.25	2.75
6.00	4.88	1.75	1.94	2.94	2.44
6.00	4.50	3.00	3.44	3.31	2.75
6.00	4.38	1.00	1.50	2.13	1.00 - 1.25
7.00	5.50	2.75	2.88	3.25	2.75
8.00	7.06	1.13	2.25	2.50	1.88
8.00	7.00	1.38	3.13	3.25	2.75
8.00	6.75	1.75	1.75	2.94	2.44
8.00	6.50	2.75	3.38	4.31	3.75
8.00	6.25	3.00	3.50	3.31	2.75
8.00	6.50	1.88	2.25	3.75	3.00
8.00	5.75	4.00	4.00	5.00	4.25
8.00	6.50	1.25	1.88	3.25	1 - 2
10.00	9.00	1.75	3.13	3.25	2.75
10.00	8.00	3.00	2.88	2.38	1.88
10.00	8.25	4.00	3.25	3.25	2.75
10.00	8.75	1.25	2.25	2.50	1.88
10.00	8.50	2.00	3.25	3.88	3.25
10.00	8.25	2.50	3.50	4.88	4.25
10.00	8.00	2.50	4.75	5.13	4.38
10.00	7.88	2.50	3.75	3.50	2.88
10.00	7.88	2.00	3.50	4.50	3.63
10.00	7.44	2.00	2.00	4.50	3.00
10.00	8.38	2.13	1.75	4.00	3.25
10.00	8.50	1.38	1.75	4.00	1.00 - 2.75



WARNING: Misuse of rigging equipment can result in serious injury up to and including loss of life. Only competent trained professionals should use Skookum products. Thoroughly inspect all equipment before each and every use and never use damaged or worn products. Skookum disclaims any liability resulting from the misuse of its products. Please take a moment to carefully review our maintenance and warnings page for more information.

Sheaves Products Manganese & Cast Steel

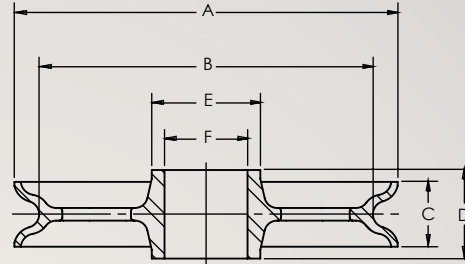

SPECIFICATIONS

SHEAVE #	ROPE SIZE (INCHES)	APPROX. WEIGHT (LBS)	MATERIAL
A-12	3/4 - 7/8	15	Manganese
T-12	3/4 - 7/8	17	Manganese
412A	3/4 - 1	23	Manganese
512	7/8 - 1	26	Manganese
2212	1 1/8 - 1 1/4	28	Manganese
F-12	1 1/8 - 1 1/4	31	Manganese
2212TM	1 1/8 - 1 1/4	28	Manganese
312	1 1/4 - 1 3/8	26	Manganese
6174	5/8 - 3/4	29	Cast Steel
6175	5/8 - 3/4	36	Cast Steel
10450	7/8	23	Manganese
103220	3/4 - 7/8	26	Manganese
T-14	3/4 - 7/8	23	Manganese
414	3/4 - 1	27	Manganese
514	7/8 - 1	36	Manganese
2214	1 1/8 - 1 1/4	40	Manganese
F-14	1 3/8 - 1 1/2	52	Manganese
2214TM	1 1/4 - 1 1/2	52	Manganese
2014	1 1/2 - 1 3/4	52	Manganese
127920	7/8	38	Manganese
5375-2	3/4 - 1	33	Manganese
416	3/4 - 1	30	Manganese
2216	1 1/8 - 1 1/4	48	Manganese
16W	1 - 1 3/8	120	Manganese
F-16	1 1/2 - 1 3/4	105	Manganese
2016	1 1/2 - 1 3/4	66	Manganese
2616	1 1/2 - 1 3/4	89	Manganese
6176	7/8 - 1	63	Cast Steel

DIMENSIONS (IN)

A OUTSIDE DIAMETER	B TREAD DIAMETER	C RIM WIDTH	D HUB WIDTH	E HUB DIAMETER	F BORE MIN-MAX
12.00	10.88	1.38	3.13	3.25	2.50
12.00	10.38	2.00	3.38	4.31	3.75
12.00	10.00	2.50	3.63	5.00	4.25
12.00	10.00	2.50	3.75	3.50	2.88
12.00	10.00	2.50	5.25	5.13	4.38
12.00	9.75	3.00	4.25	5.63	4.88
12.00	10.25	2.00	4.25	5.63	4.88
12.00	10.00	2.13	3.50	4.50	3.63
12.00	10.25	1.50	2.25	4.25	1 - 3
14.00	12.25	1.50	2.38	5.00	1 - 3
14.00	12.13	1.50	2.13	5.13	3.00
14.00	12.75	1.75	3.50	5.25	2.50 - 4.25
14.00	12.00	2.00	3.44	4.31	3.75
14.00	12.00	2.50	3.50	4.88	4.25
14.00	11.50	2.50	3.75	3.50	2.88
14.00	12.00	2.50	5.25	5.13	4.38
14.00	11.25	2.88	5.63	6.00	4.88
14.00	11.25	2.88	5.63	6.00	4.88
14.00	11.25	2.75	4.75	5.75	4.75
15.00	13.13	1.75	2.00	4.50	3.00
16.00	14.00	2.50	3.00	5.00	2.63
16.00	14.00	2.50	3.50	5.13	4.25
16.00	13.75	2.50	5.50	5.63	4.88
16.00	10.38	7.00	7.50	5.75	4.75
16.00	12.00	3.75	4.00	8.50	7.00
16.00	12.38	3.00	4.50	6.00	4.75
16.00	12.75	3.50	7.00	9.00	7.50
16.00	14.13	1.75	2.75	7.00	2.5-5.00



WARNING: Misuse of rigging equipment can result in serious injury up to and including loss of life. Only competent trained professionals should use Skookum products. Thoroughly inspect all equipment before each and every use and never use damaged or worn products. Skookum disclaims any liability resulting from the misuse of its products. Please take a moment to carefully review our maintenance and warnings page for more information.

Sheaves Products Manganese & Cast Steel

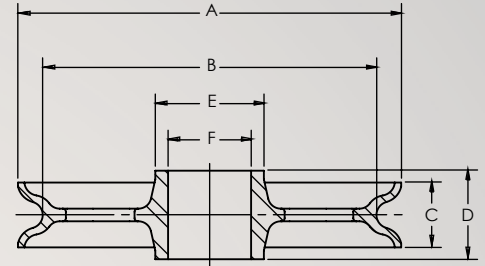

SPECIFICATIONS

SHEAVE #	ROPE SIZE (INCHES)	APPROX. WEIGHT (LBS)	MATERIAL
6177	1 - 1 1/8	71	Cast Steel
418	3/4 - 1	44	Manganese
180	1 1/8 - 1 3/8	66	Manganese
2218	1 1/8 - 1 1/4	65	Manganese
2218TM	1 1/4 - 1 1/2	65	Manganese
2000	1 1/8 - 1 1/4	88	Manganese
2220	1 - 1 1/8	57	Manganese
11055	1 1/8 - 1 1/4	95	Cast Steel
6178	1 - 1 1/4	94	Cast Steel
11096	3/4 - 1	105	Cast Steel
6179	1 - 1 1/8	118	Cast Steel
2222	1 - 1 1/4	75	Manganese
6180	1 - 1 1/4	130	Cast Steel
6124	1 - 1 1/4	140	Cast Steel
24W	1 1/4 - 1 3/8	220	Manganese
2400	1 - 1 1/8	105	Manganese
10382	1 1/2 - 1 3/4	---	Cast Steel
2624	1 1/2 - 2	210	Cast Steel
260000	1 1/4	156	Manganese
3000	1 1/4 - 1 3/8	267	Manganese
3030	1 1/4 - 1 3/8	235	Manganese
10327	1 1/4 - 1 1/2	170	Manganese
10337	1 1/4 - 1 3/8	252	Manganese
6130	3/4 - 1 1/8	175	Manganese
30W	1 3/8 - 1 1/2	350	Manganese
11060	1 1/4	310	Manganese
3600	1 3/8 - 1 5/8	460	Manganese
102240	1 1/4	---	Cast Steel
10381	1 3/8 - 1 1/2	345	Manganese
422400	2 1/2 - 3 1/2	1200	Manganese
11061	1 1/8 - 1 1/4	650	Cast Steel
614800	1 1/2 - 2	900	Manganese

DIMENSIONS (IN)

A OUTSIDE DIAMETER	B TREAD DIAMETER	C RIM WIDTH	D HUB WIDTH	E HUB DIAMETER	F BORE MIN-MAX
18.00	15.50	2.00	2.75	7.50	2.50-6.00
18.00	16.00	2.50	3.50	5.13	4.25
18.00	14.75	4.00	4.88	5.75	4.88
18.00	15.75	2.50	5.50	5.63	4.88
18.00	15.50	3.00	4.19	5.75	4.88
20.00	17.50	15.50	6.00	7.50	6.38
20.00	17.38	2.50	4.00	5.75	4.75 - 4.875
20.00	17.00	2.75	3.25	7.25	4.50-5.75
20.00	17.25	2.00	2.63	7.75	2.75-6.50
21.00	19.25	2.50	3.75	7.00	5.50
22.00	19.25	2.13	3.00	7.75	2.75-6.50
22.00	19.75	3.00	4.00	5.75	4.75-4.625
24.00	21.25	2.25	3.00	7.50	3.25-6.50
24.00	20.50	3.25	4.13	7.50	6.50
24.00	18.50	7.00	7.25	5.75	4.75
24.00	20.50	4.50	6.75	7.50	6.88
24.00	20.00	3.50	9 3/8 - 7	10.88	8.63
24.00	20.50	3.50	7.25	8.50	7.00
26.00	23.50	2.75	3.88	10.50	4.00-8.50
30.00	26.00	5.00	8.00	8.75	7.25-7.50
30.00	26.25	5.00	8.00	7.50	6.38
30.00	26.25	3.25	4.25	8.38	6.50
30.00	23.25	3.50	3.75	5.75	3.50
30.00	26.88	2.50	3.75	7.00	4.88
30.00	24.50	7.00	7.25	9.00	7.25-7.50
32.63	29.50	2.50	3.75	10.00	7.00-8.50
36.00	30.00	6.00	7.38	9.38	7.25-7.50
36.00	33.00	3.00	3.25	-	6.50
42.00	38.25	3.50	4.00	10.75	9.00
42.00	35.00	5.25	6.25	12.00	6.5-9.00
47.00	43.75	3.00	5.25	10.00	6.75-8.50
48.00	44.13	4.38	6.25	12.50	9.00



WARNING: Misuse of rigging equipment can result in serious injury up to and including loss of life. Only competent trained professionals should use Skookum products. Thoroughly inspect all equipment before each and every use and never use damaged or worn products. Skookum disclaims any liability resulting from the misuse of its products. Please take a moment to carefully review our maintenance and warnings page for more information.

Fairleads Products



Fairleads and Lead Sheaves Products



Balanced Head Fairleads Single Sheave—Flange Mounted

- Cast manganese sheaves
- Sheaves feature tapered roller bearings
- Head revolves 360° on bearings
- Alloy steel pins
- Will withstand the breaking strength of new 6 x 19 or 6 x 37 Class, EIP, IWRC, Right Regular Lay Wire Rope made to US specifications rigged at 90° angles

SPECIFICATIONS

MODEL NUMBER		WIRE ROPE SIZE ²	SHEAVE DIA. ¹	BOLT HOLE DIA.	BOLT HOLE #s	LBS KGS
FF-6	in.	3/8	6	0.95	4	70
	mm.	9	152	24.00		31
FF-7	in.	1/2	7	0.95	4	105
	mm.	13	178	24.00		48
FF-80	in.	1/2-3/4	8	0.82	8	125
	mm.	13-19	203	21.00		57
FF-10	in.	3/4-1	10	1.06	8	285
	mm.	19-25	254	27.00		129
SK100F	in.	3/4-1	10	1.06	8	295
	mm.	19-25	254	27.00		134

DIMENSIONS (IN)

	A	B	C	D	E	F	G	H
in.	10.00	10.00	6.50	8.13	5.25	5.25	6.81	2.00
mm.	254.00	254.00	165.00	206.00	133.00	133.00	173.00	51.00
in.	10.00	10.00	8.00	9.25	5.00	6.38	8.13	3.13
mm.	254.00	254.00	203.00	235.00	127.00	162.00	206.00	79.00
in.	14.00	14.00	10.50	10.50	6.25	7.25	8.75	5.25
mm.	356.00	356.00	267.00	267.00	159.00	184.00	222.00	133.00
in.	18.50	18.50	11.00	14.25	10.00	8.75	10.50	3.00
mm.	470.00	470.00	279.00	362.00	254.00	222.00	267.00	76.00
in.	14.00	14.00	12.50	12.25	7.50	8.75	11.50	6.00
mm.	356.00	356.00	318.00	311.00	191.00	222.00	292.00	152.00

Please contact us for any custom product or non-standard sizes.

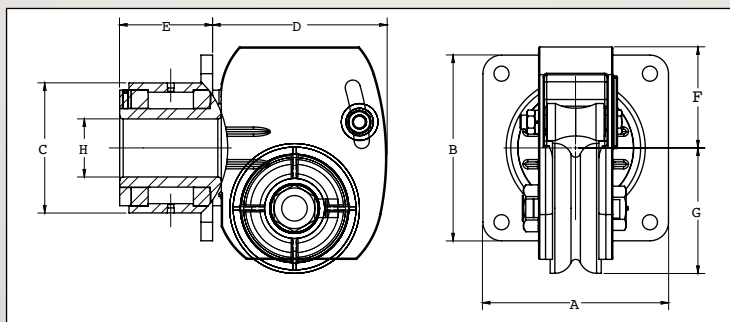

WARNING: Misuse of rigging equipment can result in serious injury up to and including loss of life. Only competent trained professionals should use Skookum products. Thoroughly inspect all equipment before each and every use and never use damaged or worn products. Skookum disclaims any liability resulting from the misuse of its products. Please take a moment to carefully review our maintenance and warnings page for more information.

Fairleads and Lead Sheaves Products

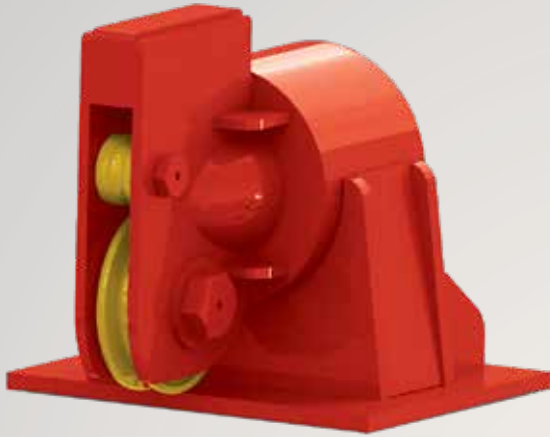

Balanced Head Fairleads Single Sheave—Deck Mounted

- Available as standard and wide throat (mooring) models for easy passing of wire rope eyes, splices and shackles
- Cast manganese sheaves
- Sheaves feature tapered roller bearings
- Bronze bushed sheaves with stainless steel pins available on request
- Head revolves 360° on roller bearings
- Alloy steel pins
- Will withstand the breaking strength of new 6 x 19 or 6 x 37 Class, EIP, IWRC, Right Regular Lay Wire Rope made to US specifications rigged at 90° angles

SPECIFICATIONS

MODEL NUMBER		WIRE ROPE SIZE ²	SHEAVE DIA. ¹	BOLT HOLE DIA.	LBS KGS
F-6	in.	3/8	6	0.95	70
	mm.	10	152	24.00	32
F-7	in.	1/2	7	0.95	105
	mm.	13	178	21.00	48
F-802	in.	1/2-3/4	8	0.95	170
	mm.	13-19	203	21.00	77
F-10	in.	3/4-1	10	1.03	435
	mm.	19-25	254	26.00	197
F-1002	in.	3/4-1	10	1.03	400
	mm.	19-25	254	26.00	181

DIMENSIONS (IN)

	A	B	C	D	E	F	G	H	J
in.	9.25	7.50	12.06	8.13	13.44	5.25	6.81	2.00	9.56
mm.	235.00	191.00	306.00	206.00	341.00	133.00	173.00	51.00	243.00
in.	11.00	8.00	14.50	9.25	15.50	6.38	8.13	3.13	11.63
mm.	279.00	203.00	368.00	235.00	394.00	162.00	206.00	79.00	295.00
in.	15.25	7.50	16.13	10.50	17.50	7.25	8.75	5.25	13.75
mm.	387.00	191.00	410.00	267.00	445.00	184.00	222.00	133.00	349.00
in.	20.00	12.00	19.25	14.25	24.50	8.75	10.50	3.00	15.00
mm.	508.00	305.00	489.00	362.00	622.00	222.00	267.00	76.00	381.00
in.	12.00	20.00	20.25	12.25	21.88	8.75	11.50	6.00	17.13
mm.	305.00	508.00	514.00	311.00	557.00	222.00	292.00	152.00	435.00

Please contact us for any custom product or non-standard sizes.

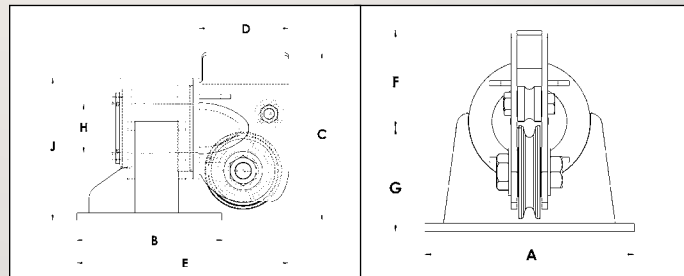

Fairleads and Lead Sheaves Products



Balanced Head Fairleads Double Sheave—Flange Mounted

- Cast manganese sheaves
- Sheaves feature tapered roller bearings
- Head revolves 360° on bearings
- Alloy steel pins
- Will withstand the breaking strength of new 6 x 19 or 6 x 37 Class, EIP, IWRC, Right Regular Lay Wire Rope made to US specifications rigged at 90° angles

SPECIFICATIONS

MODEL NUMBER		WIRE ROPE SIZE ²	BOLT DIA	BOLT HOLE #s	LBS KGS
UF 100-4	in.	To 3/8	0.50	6	53
	mm.	10	13.00		32
UF 100-6	in.	To 1/2	0.63	6	125
	mm.	13	16.00		57
UF 100-8	in.	To 5/8	0.63	6	155
	mm.	16	16.00		70
UF 100-10	in.	To 3/4	0.63	6	185
	mm.	19	16.00		84
UF 100-12	in.	To 7/8	0.75	6	360
	mm.	22	19.00		163

DIMENSIONS (IN)

	A	B	C	D	E	F	G	H	J	K	L
in.	1.00	2.75	4.00	1.38	3.00	10.00	8.38	4.44	1.50	6.38	2.69
mm.	25.00	70.00	102.00	35.00	76.00	254.00	213.00	113.00	38.00	162.00	68.00
in.	1.88	4.63	6.00	2.00	4.00	12.13	10.00	9.50	2.25	7.25	3.88
mm.	48.00	117.00	152.00	51.00	102.00	308.00	254.00	241.00	57.00	184.00	98.00
in.	1.88	6.00	8.00	2.25	4.00	12.13	10.00	12.00	2.25	8.25	4.88
mm.	48.00	152.00	203.00	57.00	102.00	308.00	254.00	305.00	57.00	210.00	124.00
in.	1.88	8.50	10.00	2.00	4.00	12.13	10.00	14.50	2.25	9.25	5.88
mm.	48.00	216.00	254.00	51.00	102.00	308.00	254.00	368.00	57.00	235.00	149.00
in.	2.38	10.00	12.00	2.50	5.38	15.75	13.50	18.44	2.25	11.75	7.00
mm.	60.00	254.00	305.00	64.00	137.00	400.00	343.00	468.00	57.00	298.00	178.00

Please contact us for any custom product or non-standard sizes.

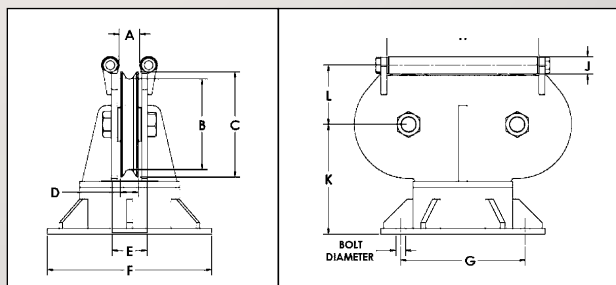

WARNING: Misuse of rigging equipment can result in serious injury up to and including loss of life. Only competent trained professionals should use Skookum products. Thoroughly inspect all equipment before each and every use and never use damaged or worn products. Skookum disclaims any liability resulting from the misuse of its products. Please take a moment to carefully review our maintenance and warnings page for more information.

Fairleads and Lead Sheaves Products



Unbalanced Head Fairleads Single Sheave—Flange Mounted

- Cast manganese sheaves
- Sheaves feature tapered roller bearings
- Head revolves 360° on bearings
- Alloy steel pins
- Will withstand the breaking strength of new 6 x 19 or 6 x 37 Class, EIP, IWRC, Right Regular Lay Wire Rope made to US specifications rigged at 90° angles

SPECIFICATIONS

MODEL NUMBER		WIRE ROPE SIZE ²	BOLT DIA	BOLT HOLE #s	LBS KGS
UF 50-4	in.	To 3/8	0.50	4	25
	mm.	10	13.00		16
UF 50-6	in.	To 1/2	0.63	6	70
	mm.	13	16.00		32
UF 50-8	in.	To 5/8	0.63	6	85
	mm.	16	16.00		39

DIMENSIONS (IN)

	A	B	C	D	E	F	G	H	J	K
in.	1.38	4.00	2.75	8.00	6.75	1.63	1.63	4.75	5.00	6.75
mm.	35.00	102.00	70.00	203.00	171.00	41.00	41.00	121.00	127.00	171.00
in.	2.00	6.00	4.63	9.75	7.88	2.00	2.00	5.25	6.25	8.25
mm.	51.00	152.00	117.00	248.00	200.00	51.00	51.00	133.00	159.00	210.00
in.	2.25	8.00	6.00	9.75	7.88	2.00	2.00	5.25	6.25	9.25
mm.	57.00	203.00	152.00	248.00	200.00	51.00	51.00	133.00	159.00	235.00

Please contact us for any custom product or non-standard sizes.

¹Roller sheave bearings on UF 50-4.

²Specify rope size when ordering.

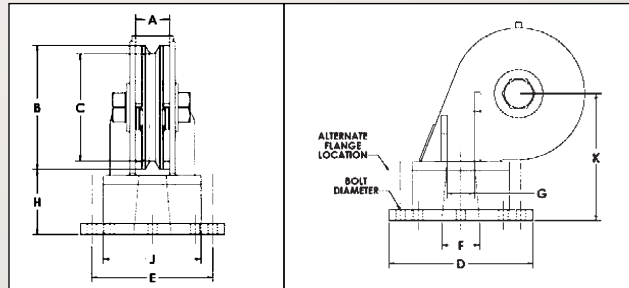

WARNING: Misuse of rigging equipment can result in serious injury up to and including loss of life. Only competent trained professionals should use Skookum products. Thoroughly inspect all equipment before each and every use and never use damaged or worn products. Skookum disclaims any liability resulting from the misuse of its products. Please take a moment to carefully review our maintenance and warnings page for more information.

Fairleads and Lead Sheaves Products



Vertical Lead Sheaves Weld-Down or Bolt-Down Bases

- Bronze bushed sheaves with optional tapered roller bearings
- Alloy steel pins
- Will withstand the breaking strength of new 6 x 19 or 6 x 37 Class, EIP, IWRC, Right Regular Lay Wire Rope made to US specifications rigged at 90° angles
- Available on request:
 - Sheave sizes above 42"
 - Double sheave models
 - Custom dimensions

SPECIFICATIONS

MODEL NUMBER		SUGGESTED WIRE SIZE	SHEAVE DIAMETER	PIN DIAMETER
VLS-4	in.	1/4-3/8	4	3/4
	mm.	6-10	101	19
VLS-6	in.	5/16-1/2	6	1
	mm.	8-13	152	25
VLS-8	in.	3/8-5/8	8	1 1/2
	mm.	10-16	203	38
VLS-12	in.	1/2-3/4	12	2
	mm.	13-19	305	51
VLS-14	in.	5/8-3/4	14	2 1/2
	mm.	16-19	356	64
VLS-16	in.	3/4-1	16	2 1/2
	mm.	19-25	406	64
VLS-18	in.	3/4-1	18	2 1/4
	mm.	19-25	457	56

DIMENSIONS (IN)

	A	B	C	D
in.	4.00	6.00	3.00	0.50
mm.	102.00	152.00	76.00	13.00
in.	4.00	8.00	4.50	0.50
mm.	102.00	203.00	114.00	13.00
in.	6.50	10.00	6.00	0.63
mm.	165.00	305.00	152.00	19.00
in.	9.50	16.00	8.00	0.88
mm.	241.00	406.00	203.00	22.00
in.	9.50	16.00	9.00	0.88
mm.	241.00	406.00	229.00	22.00
in.	10.00	18.00	10.50	0.88
mm.	254.00	457.00	267.00	22.00
in.	11.00	19.00	12.50	1.00
mm.	279.00	483.00	318.00	25.00

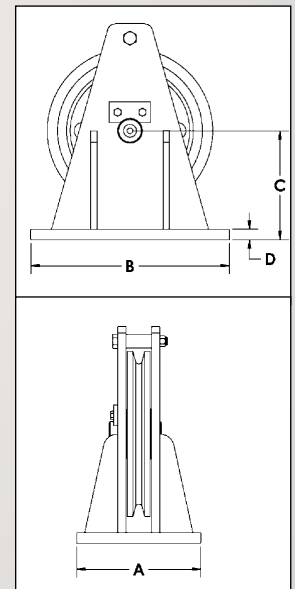

WARNING: Misuse of rigging equipment can result in serious injury up to and including loss of life. Only competent trained professionals should use Skookum products. Thoroughly inspect all equipment before each and every use and never use damaged or worn products. Skookum disclaims any liability resulting from the misuse of its products. Please take a moment to carefully review our maintenance and warnings page for more information.

Fairleads and Lead Sheaves Products

Horizontal Lead Sheaves Weld-Down or Bolt-Down Bases



- Bronze bushed sheaves
- Optional Bronze Bushing or Roller Bearing
- Alloy steel pins
- Will withstand the breaking strength of new 6 x 19 or 6 x 37 Class, EIP, IWRC, Right Regular Lay Wire Rope made to US specifications rigged at 90° angles
- Available on request:
 - Sheave sizes above 42"
 - Double sheave models
 - Custom dimensions

SPECIFICATIONS

MODEL NUMBER		WIRE ROPE SIZE	SHEAVE DIAMETER	PIN DIAMETER
HLS-8	in.	3/8-1/2	8	1 1/2
	mm.	10-13	203	38
HLS-12	in.	1/4-5/8	12	2
	mm.	6-16	305	51
HLS-14	in.	5/8-3/4	14	2
	mm.	16-19	356	51
HLS-16	in.	3/4-7/8	16	3 1/2
	mm.	16-19	406	89
HLS-18	in.	7/8-1	18	3 1/2
	mm.	22-25	457	89

DIMENSIONS (IN)

	A WIDTH ¹	B LENGTH	C SHEAVE CENTER	D BASE THICKNESS
in.	12.00	10.00	1.38	0.63
mm.	305.00	254.00	35.00	16.00
in.	18.00	18.00	1.75	0.75
mm.	457.00	457.00	44.00	19.00
in.	19.00	19.00	2.25	0.88
mm.	483.00	483.00	57.00	22.00
in.	21.00	21.00	2.50	0.88
mm.	533.00	533.00	64.00	22.00
in.	28.00	28.00	2.50	1.13
mm.	711.00	711.00	64.00	29.00

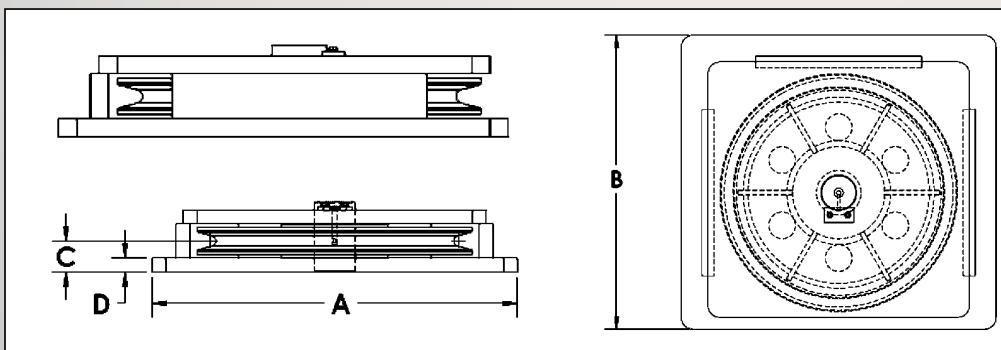

Fairleads and Lead Sheaves Products



Horizontal Deck Sheaves 'O' and 'R' Style

- Heavy duty, extra wide manganese steel sheaves
- Sheaves feature tapered roller bearings
- Bronze bushed sheaves optional
- Available for wire and synthetic rope
- Alloy steel pins
- Will withstand the breaking strength of new
6 x 19 or 6 x 37 Class, EIP, IWRC, Right Regular
Lay Wire Rope made to US specifications rigged
at 90° angles

SPECIFICATIONS

MODEL NUMBER		WIRE ROPE SIZE	LBS/KGS
DS-10W-0	in.	1 max	200
	mm.	25 max	90
DS-16W-0	in.	1 1/4 max	360
	mm.	32 max	163
DS-16W-R	in.	1 1/4 max	570
	mm.	32 max	259
DS-24W-0	in.	1 3/8 max	621
	mm.	35 max	282
DS-30W-0	in.	1 1/2 max	1000
	mm.	38 max	454

DIMENSIONS (IN)

	A	B	C	D	E	F	G	H	J	K	L	M
in.	10.00	8.00	5.50	4.00	7.75	7.75	17.00	2.25	—	—	—	—
mm.	254.00	203.00	140.00	102.00	197.00	197.00	432.00	57.00	—	—	—	—
in.	16.00	10.00	7.00	5.00	10.00	12.00	27.00	2.00	—	—	—	—
mm.	406.00	254.00	178.00	127.00	254.00	305.00	686.00	51.00	—	—	—	—
in.	16.00	10.00	7.00	5.00	10.00	12.00	37.25	2.00	2.00	14.25	13.00	8.00
mm.	406.00	254.00	178.00	127.00	254.00	305.00	946.00	51.00	51.00	362.00	330.00	203.00
in.	24.00	18.50	7.00	5.13	10.25	18.00	35.00	2.00	—	—	—	—
mm.	610.00	470.00	178.00	130.00	260.00	457.00	889.00	51.00	—	—	—	—
in.	30.00	24.50	7.00	5.25	10.50	22.00	41.00	2.00	—	—	—	—
mm.	762.00	622.00	178.00	133.00	267.00	559.00	1041.00	51.00	—	—	—	—

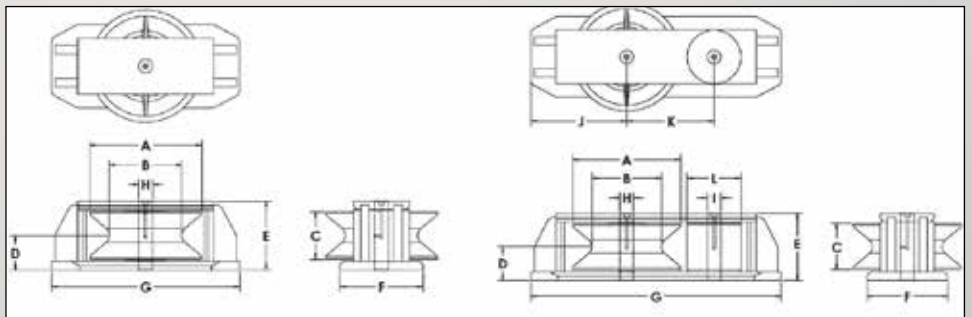

WARNING: Misuse of rigging equipment can result in serious injury up to and including loss of life. Only competent trained professionals should use Skookum products. Thoroughly inspect all equipment before each and every use and never use damaged or worn products. Skookum disclaims any liability resulting from the misuse of its products. Please take a moment to carefully review our maintenance and warnings page for more information.

Fairleads and Lead Sheaves Products

Roller Fairleads Bolt-Down Style

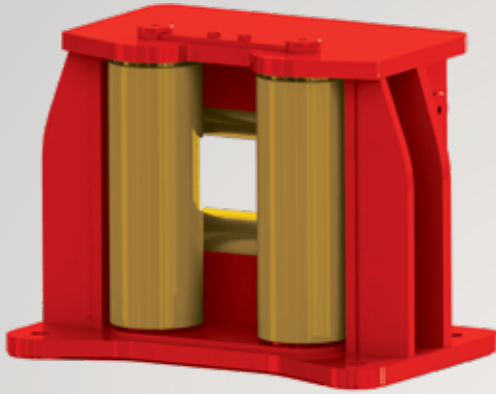

- Alloy steel rollers—heat treated
- Bronze bushings
- Alloy steel pins
- Bolt down bases

SPECIFICATIONS

MODEL NUMBER		WIRE ROPE SIZE ²	VERTICAL ROLLER	HORIZONTAL ROLLER	OPENING W x H	BOLT HOLE #s	LBS KGS
RFB-0	in.	5/16-3/8	2 1/4x6 1/2	2 1/4x6 1/2	2 1/4x2 1/4	4	52
	mm.	8-10	57x165	57x165	57x57		24
RFB-1	in.	5/8-7/8	4x11 3/8	4x11 3/8	2 3/4x2 3/4	4	235
	mm.	16-22	102x289	102x289	70x70		107
RFB-2	in.	1-1 1/4	6x15 3/8	5x11	5x4	4	700
	mm.	25-32	152x391	127x279	127x102		318

DIMENSIONS (IN)

	A	B	C	D	E	F	G	H
in.	12.00	5.25	8.19	10.25	3.88	0.50	0.78	1.00
mm.	305.00	133.00	208.00	260.00	98.00	13.00	20.00	25.00
in.	17.50	10.50	13.13	15.00	8.00	0.75	1.06	1.38
mm.	444.00	267.00	333.00	381.00	203.00	19.00	27.00	35.00
in.	26.00	17.00	18.50	22.00	12.50	1.13	1.53	1.50
mm.	660.00	432.00	470.00	559.00	318.00	29.00	39.00	38.00

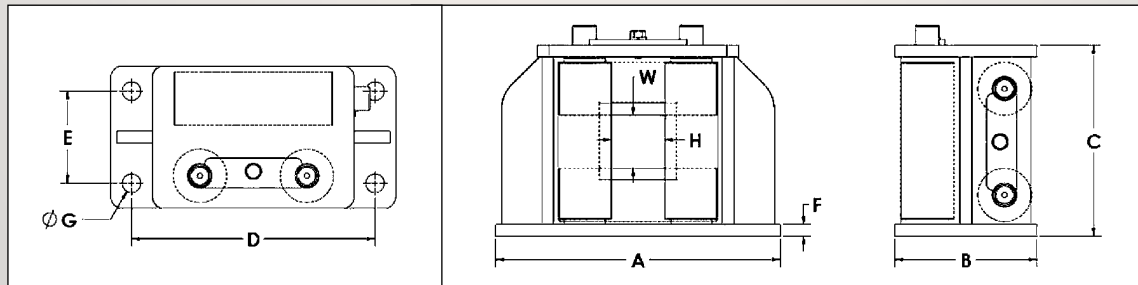

WARNING: Misuse of rigging equipment can result in serious injury up to and including loss of life. Only competent trained professionals should use Skookum products. Thoroughly inspect all equipment before each and every use and never use damaged or worn products. Skookum disclaims any liability resulting from the misuse of its products. Please take a moment to carefully review our maintenance and warnings page for more information.

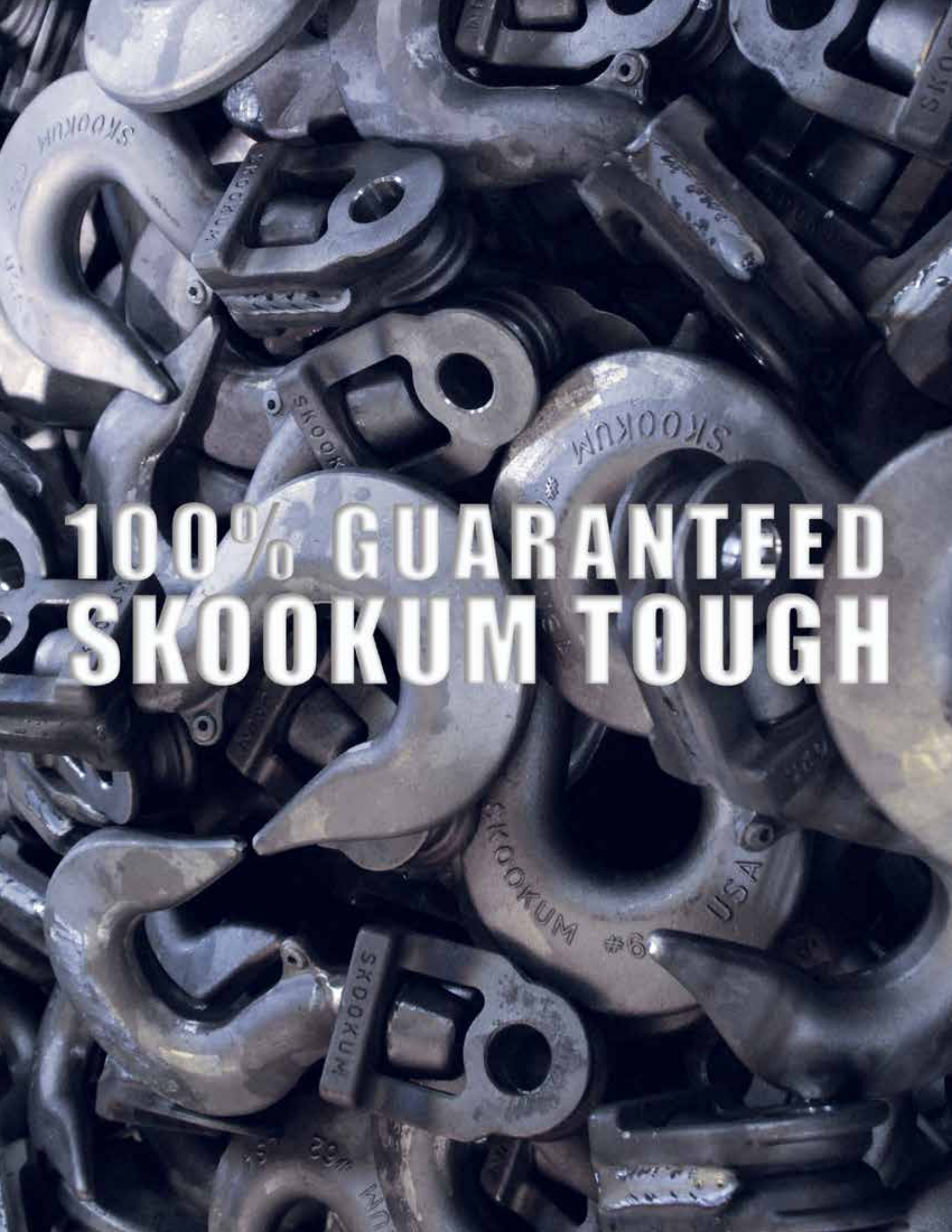

**100% GUARANTEED
SKOOKUM TOUGH**

Shackle Products



Shackle Products

Mandel Fairlead Shackle



- Forged, quenched and tempered
- Superior strength, hardness & uniformity
- Stainless steel mooring shackle with sleek shape designed to pass through fairleads
- Size & working load permanently imprinted

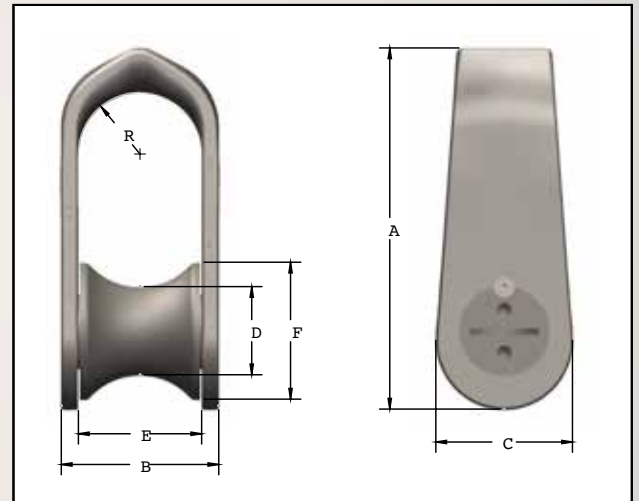

SPECIFICATIONS

PART #	WLL* (TONNES)	PROOF LOAD	ULTIMATE LOAD	WEIGHT (KGS)	WEIGHT (LBS)
1001265	60.00	70.00	120.00	17.90	39.50

DIMENSIONS (IN)

A		B		C		D		E		F		R	
IN	MM	IN	MM	IN	MM	IN	MM	IN	MM	IN	MM	IN	MM
13.2	335	5.75	146	5.10	130	3.20	81	4.50	114	5.00	127	2.25	57

*All Load Weights in Metric Tonnes
Additional sizes available by special order



WARNING: Misuse of rigging equipment can result in serious injury up to and including loss of life. Only competent trained professionals should use Skookum products. Thoroughly inspect all equipment before each and every use and never use damaged or worn products. Skookum disclaims any liability resulting from the misuse of its products. Please take a moment to carefully review our maintenance and warnings page for more information.

Smart Shackle™ Series Instrumented Load Shackles

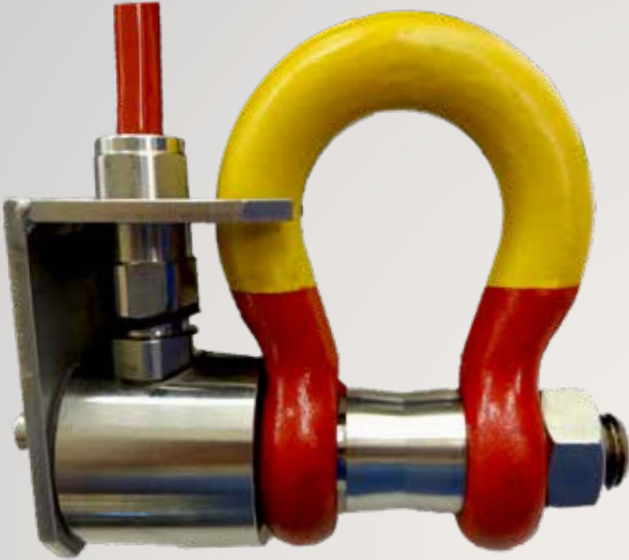

- Skookum Gold Standard Forgings
- 3.5 ton to 410 ton capacities.
- Provides load measurement with cabled output for use with the LCI-80x Smart Shackle™ Controller.
- Compatible with digital displays, PLCs, data acquisition systems (DAC), etc.
- Standard output: cabled 4-20mA.
- Optional outputs include: mV/V, RS-485, and wireless.
- Traceable calibration certificate provided.
- Applications include heavy lifting, cable tension monitoring, crane weighing, structural and other load testing.
- Ultimate load capacity at 300% of Working Load Limit

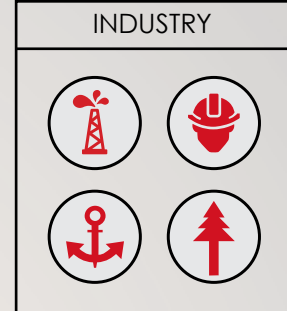

Proudly made by Skookum in the USA.
The only domestic load shackle with full certification, traceability and manufacturer's warranty.

SPECIFICATIONS DIMENSIONS (IN)

PART #	SIZE (INCHES)	WLL ¹ (TONS)	WEIGHT (LBS)	NOMINAL D	W	L	B	R	P
SKM-1006458	5/8	3.50	2.00	.75	1.06 ± .063	2.50 ± .125	1.75	1.63	0.75
SKM-1006459	1	7.00	5.50	1.13	1.69 ± .063	3.75 ± .250	2.69	2.25	1.13
SKM-1006466	1.125	12.00	8.00	1.13	1.81 ± .063	4.25 ± .25	2.94	2.63	1.25
SKM-1006456	2	52.00	42.00	2.00	3.25 ± .125	7.75 ± .250	5.75	5.00	2.25
SKM-1006457	3	117.00	136.00	3.00	5.00 ± .126	13.00 ± .750	7.88	6.50	3.25

¹Design factor is 3 to 1

IP PROTECTION: IP67/68

ACCURACY: +/- 1%

OPERATING TEMP: -25o C to +70o C

Please contact us for any custom product or non-standard sizes.

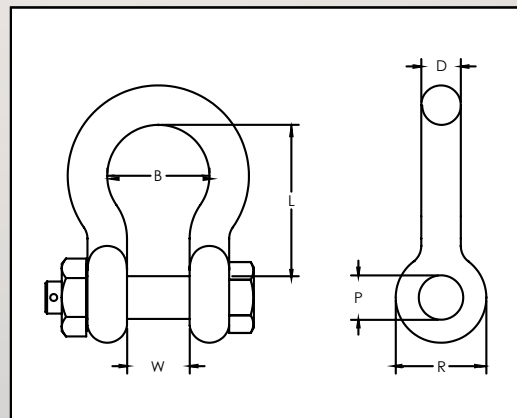

WARNING: Misuse of rigging equipment can result in serious injury up to and including loss of life. Only competent trained professionals should use Skookum products. Thoroughly inspect all equipment before each and every use and never use damaged or worn products. Skookum disclaims any liability resulting from the misuse of its products. Please take a moment to carefully review our maintenance and warnings page for more information.

Smart Shackle™ Series Instrumentation



Report Generator PDF Report

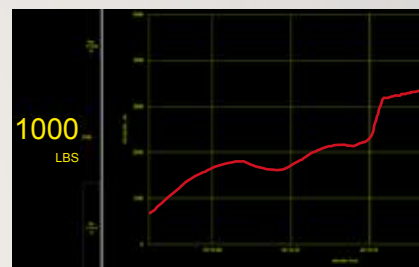

SenseDAC Software

LCI-80X SMART SHACKLE™ CONTROLLER BY MEASUREMENT TECHNOLOGY NORTHWEST

Portable Testing & Data Acquisition System

- Display and monitor one or more Smart Shackle(s) in real time with USB data-logging, audible alarm, configurable set point alarms, relays and outputs for control functionality.
- Report Generator Software creates turn-key branded reports for load tests and other applications.
- SenseDAC software provides remote display of Smart Shackle load data in real time with graphical user interfaces featuring numerical, peak, trending load data, graphing, and reporting views. SenseDAC can bridge the gap between your Smart Shackle and cloud data monitoring.

OTHER DISPLAY OPTIONS



Wireless Handheld Display



Scoreboard



Dash Mount LCI-80x

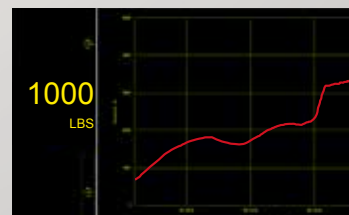

SenseDAC Software



WARNING: Misuse of rigging equipment can result in serious injury up to and including loss of life. Only competent trained professionals should use Skookum products. Thoroughly inspect all equipment before each and every use and never use damaged or worn products. Skookum disclaims any liability resulting from the misuse of its products. Please take a moment to carefully review our maintenance and warnings page for more information.

Shackle Products



No. 263
Screw Pin Shackle Eyed Pin
Available 1/2" - 3"



No. 264
Screw Pin Shackle
Pin Hex Head
Available 1/2" - 2"



No. 320
Safety Pin Shackle
Available 1/2" - 4 1/2"



No. 330
Towing Shackle Double
Nut with Locking Bolts
Available 7/8" - 4 1/2"

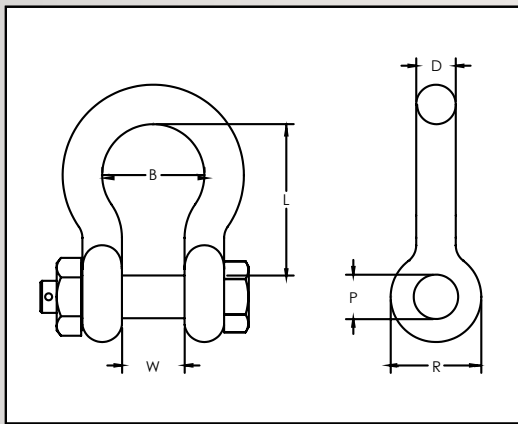

Alloy Anchor Shackles

- Skookum Gold Standard Forgings
- All sizes are forged, quenched and tempered
- Enamel, zinc plate or galvanized finish
- Custom sizes & materials (stainless steel, etc.) are available upon request
- Superior strength, hardness & uniformity
- Size & working load permanently imprinted
- Material heat codes imprinted on bale and pin

SPECIFICATIONS

SIZE (INCHES)	WLL ¹ (TONS)	WEIGHT ² (LBS)	STOCK #			
			#263	#264	#320	#330
1/2	5.00	1.00	626304	626404	632004	633004
5/8	7.00	2.00	626305	626405	632005	633005
3/4	9.00	3.00	626306	626406	632006	633006
7/8	12.00	4.00	626307	626407	632007	633007
1	16.00	5.50	626308	626408	632008	633008
1 1/8	18.00	8.00	626309	626409	632009	633009
1 1/4	21.00	11.00	626310	626410	632010	633010
1 3/8	26.00	14.00	626311	626411	632011	633011
1 1/2	31.00	18.00	626312	623412	632012	633012
1 5/8	35.00	23.00	626313	626413	632013	633013
1 3/4	41.00	30.00	626314	626414	632014	633014
2	52.00	42.00	626316	626416	632016	633016
2 1/4	67.00	57.00	626318	623418	632018	633018
2 1/2	82.00	85.00	628320	626420	632020	633020
2 3/4	104.00	100.00	626322	626422	632022	633022
3	117.00	136.00	626324	626424	632024	633024
3 1/2	150.00	256.00	—	—	632028	633028
4	175.00	310.00	—	—	632032	633032

DIMENSIONS (IN)

D	W	L	B	R	P
0.50	0.81 ± .125	1.88 ± .125	1.28	1.44	0.63
0.63	1.06 ± .0625	2.50 ± .125	1.75	1.63	0.75
0.75	1.25 ± .0625	2.88 ± .25	2.00	1.84	0.88
0.88	1.44 ± .0625	3.31 ± .25	2.28	2.13	1.00
1.00	1.69 ± .0625	3.75 ± .25	2.69	2.25	1.13
1.13	1.81 ± .0625	4.25 ± .25	2.94	2.63	1.25
1.25	2.03 ± .0625	4.63 ± .25	3.25	3.00	1.38
1.38	2.25 ± .125	5.25 ± .25	3.63	3.25	1.50
1.50	2.38 ± .125	5.75 ± .25	3.88	3.44	1.63
1.63	2.63 ± .125	6.25 ± .25	4.63	4.00	1.75
1.75	2.88 ± .125	7.00 ± .25	5.00	4.25	2.00
2.00	3.25 ± .125	7.75 ± .50	5.75	5.00	2.25
2.25	3.88 ± .125	9.25 ± .50	6.50	5.50	2.50
2.50	4.13 ± .125	10.50 ± .50	7.25	5.88	2.75
2.75	4.50 ± .125	11.50 ± .75	7.50	6.25	3.00
3.00	5.00 ± .125	13.00 ± .75	7.88	6.50	3.25
3.50	5.75 ± .25	15.00 ± .75	9.50	8.00	3.75
4.00	6.55 ± .25	17.00 ± .75	11.00	9.25	4.25

¹Ton=2,00lbs - Design factor is 5 to 1.

²Weights vary slightly with style of shackle pin used. Specifications subject to change without notice.

 **WARNING:** Misuse of rigging equipment can result in serious injury up to and including loss of life. Only competent trained professionals should use Skookum products. Thoroughly inspect all equipment before each and every use and never use damaged or worn products. Skookum disclaims any liability resulting from the misuse of its products. Please take a moment to carefully review our maintenance and warnings page for more information.

Shackle Products



No. 270
Screw Pin Shackle Eyed Pin
Available 1" thru 2"



No. 271
Screw Pin Shackle
Hex Head Pin
Available 1" thru 2"



No. 321
Safety Pin Shackle
Available 1" thru 4 1/2"

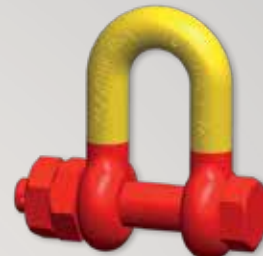

No. 325
Towing Shackle Double Nut
with Locking Bolts
Available 1 1/2" thru 4 1/2"

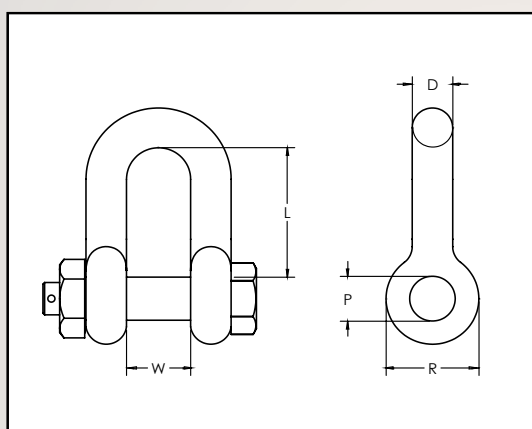

Alloy Chain Shackles

- Skookum Gold Standard Forgings
- All sizes are forged, quenched and tempered
- Enamel, zinc plate or galvanized finish
- Custom sizes & materials (stainless steel, etc..) are available upon request
- Superior strength, hardness & uniformity
- Size & working load permanently imprinted
- Material heat codes imprinted on bale and pin

SPECIFICATIONS

SIZE (INCHES)	WLL ¹ (TONS)	WEIGHT ² (LBS)	STOCK #			
			#270	#271	#321	#325
1	16.00	5.50	627008	627108	632108	—
1 1/8	18.00	6.60	627009	627109	632109	—
1 1/4	21.00	8.90	627010	627110	632110	—
1 3/8	26.00	12.00	627011	627111	632111	—
1 1/2	31.00	16.20	627012	627112	632112	—
1 5/8	35.00	21.00	627013	627113	632113	—
1 3/4	41.00	25.00	627014	627114	632114	632514
2	52.00	36.00	627016	627116	632116	632516
2 1/4	67.00	60.00	—	—	632118	632518
2 1/2	82.00	74.00	—	—	632120	632520
2 3/4	104.00	90.00	—	—	632122	632522
3	117.00	110.00	—	—	632124	632524
3 1/2	150.00	200.00	—	—	632128	632528
4	175.00	310.00	—	—	632132	632532

¹Ton=2,00lbs - Design factor is 5 to 1.

²Weights vary slightly with style of shackle pin used. Specifications subject to change without notice.

DIMENSIONS (IN)

D	W	L	R	P
1.00	1.69 +/- 0.6	3.25 ± .25	2.25	1.13
1.13	1.81 ± 0.13	3.56 ± .25	2.63	1.25
1.25	2.03 ± .0625	3.94 ± .25	2.88	1.38
1.38	2.25 ± .125	4.44 ± .25	3.25	1.50
1.50	2.38 ± .125	4.88 ± .25	3.44	1.63
1.63	2.63 ± .125	5.25 ± .25	4.00	1.75
1.75	2.88 ± .125	5.75 ± .25	4.50	2.00
2.00	3.25 ± .125	6.75 ± .50	5.13	2.25
2.25	3.88 ± .125	7.13 ± .50	5.25	2.50
2.50	4.13 ± .125	8.00 ± .50	6.25	2.75
2.75	4.50 ± .125	8.25 ± .75	6.25	3.00
3.00	5.13 ± .125	9.00 ± .75	6.50	3.25
3.50	5.75 ± .25	10.50 ± .75	8.00	3.75
4.00	6.50 ± .25	12.00 ± .75	9.00	4.25



WARNING: Misuse of rigging equipment can result in serious injury up to and including loss of life. Only competent trained professionals should use Skookum products. Thoroughly inspect all equipment before each and every use and never use damaged or worn products. Skookum disclaims any liability resulting from the misuse of its products. Please take a moment to carefully review our maintenance and warnings page for more information.

Shackle Products

Sheet Pile Shackle



- The No. 59A shackles were specifically designed for pulling sheet piling. They are equipped with a easy opening pin which will not detach and become lost. No tools are required.
- Max opening with pin in open (unlocked) position
- Design factor is 5 to1
- Replacement pins must be replaced or repaired by Skookum in Hubbard, OR.

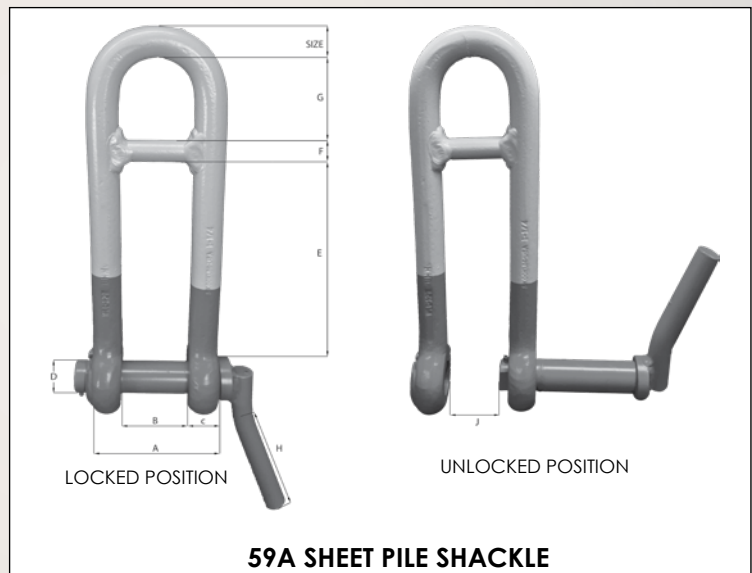

SPECIFICATIONS

SIZE	PART #	WLL ¹ (TONS)	WEIGHT (LBS)	OPENING ² J
1	605908	8.00	10.00	1 3/4
1 1/8	605909	10.00	13.50	1 7/8
1 1/4	605910	12.00	18.00	2.00
1 1/2	605912	17.00	29.00	2 1/8
1 3/4	605914	24.00	45.00	2 1/2
2	605916	30.00	63.00	3.00

¹Design factor is 5 to 1.

²Max opening with pin in open (unlocked) position.

Tons = 2000lbs

DIMENSIONS (IN)

A	B	C	D	E	F	G	H
4.25	2.25	1.00	1.13	7.00 ± .25	0.63	2.38	5.00
4.50	2.50	1.00	1.25	8.00 ± .50	0.75	3.00	5.00
5.25	2.75	1.25	1.38	9.00 ± .50	0.88	3.00	5.00
6.25	3.00	1.50	1.63	10.00 ± .50	1.13	3.50	6.00
7.00	3.50	1.75	2.00	11.00 ± .50	1.25	4.00	7.00
8.00	4.00	2.00	2.25	12.00 ± .75	1.38	4.50	8.00

WARNING: Misuse of rigging equipment can result in serious injury up to and including loss of life. Only competent trained professionals should use Skookum products. Thoroughly inspect all equipment before each and every use and never use damaged or worn products. Skookum disclaims any liability resulting from the misuse of its products. Please take a moment to carefully review our maintenance and warnings page for more information.

Shackle Products



Ground Release Sheet Pile Shackle

- Equipped with Skookum #320 bolt type anchor shackle
- Built with high-strength steel
- 12" lg. stainless steel release cable with thimble
- Design factor is 4 to1
- Repair Kit Available

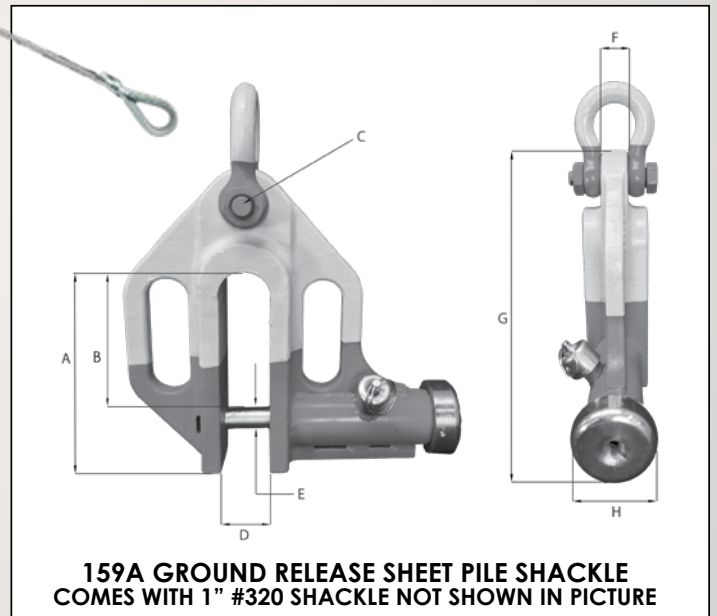

SPECIFICATIONS

PART #	WLL ¹ (TONS)	WEIGHT (LBS)	REPAIR KIT #
615908	8.00	45.00	615908K
615912	12.00	70.00	615912K

DIMENSIONS (IN)

A	B	C	D	E	F	G	H
9.00	6.38	0.94	2.00	1.13	1.00	11.68	3.50
10.75	8.13	1.19	2.25	1.13	1.50	15.25	4.00

¹Design factor is 4 to 1.

²Max opening with pin in open (unlocked) position.

Tons = 2000lbs



WARNING: Misuse of rigging equipment can result in serious injury up to and including loss of life. Only competent trained professionals should use Skookum products. Thoroughly inspect all equipment before each and every use and never use damaged or worn products. Skookum disclaims any liability resulting from the misuse of its products. Please take a moment to carefully review our maintenance and warnings page for more information.

Masterlink Products

Connecting Link Series



- Grade 8
- Design Factor 4:1
- Reliable & Durable
- Drop Forged Alloy
- Fatigue Tested per EN 1677-4
- Easily connect components to slings

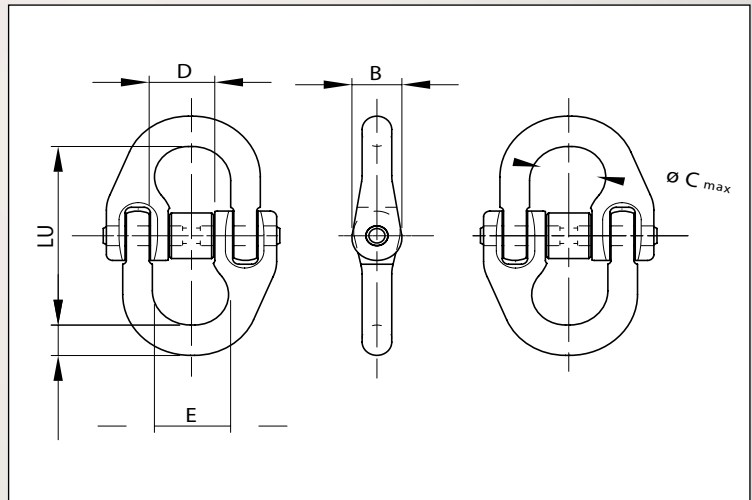

SPECIFICATIONS

CHAIN IN.	PART #	WLL ¹ (LBS)	WEIGHT (LBS)	PACKAGED QTY
.75	1810208R	28300	4.20	1
.875	1810228R	34200	7.00	1
1.0	1810268R	47700	10.80	1
1.25	1810328R	72300	18.20	1

¹Design factor is 4 to 1.

DIMENSIONS (IN)

A	B	C	D	E	LU
.75	1.00	1.3125	1.5625	1.75	2
.875	1.125	1.50	1.75	2.00	2.25
1.00	1.25	1.875	2.00	2.125	2.5625
1.25	1.50	2.4375	2.25	2.6875	3.125

WARNING: Misuse of rigging equipment can result in serious injury up to and including loss of life. Only competent trained professionals should use Skookum products. Thoroughly inspect all equipment before each and every use and never use damaged or worn products. Skookum disclaims any liability resulting from the misuse of its products. Please take a moment to carefully review our maintenance and warnings page for more information.

Masterlink Products

Connecting Link Series



- Grade 10
- Design Factor 4:1
- Reliable & Durable
- Drop Forged Alloy
- Fatigue Tested per EN 1677-4
- Easily connect components to slings

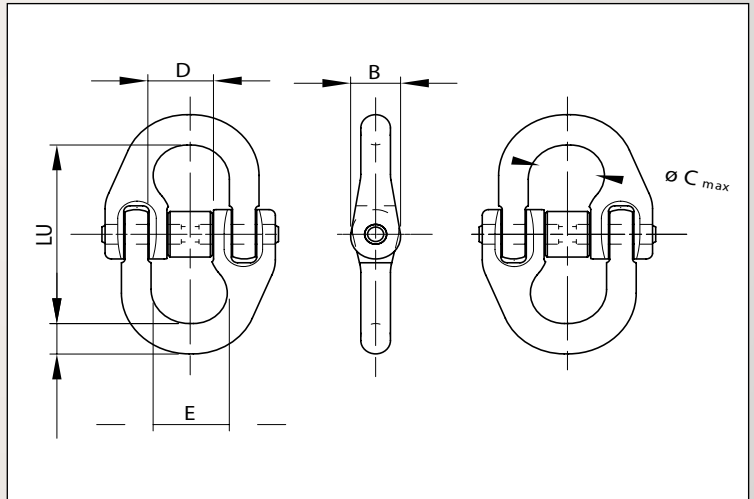

SPECIFICATIONS

CHAIN IN.	PART #	WLL ¹ (LBS)	WEIGHT (LBS)	PACKAGED QTY
.25	281006HB	3100	.20	30
.3125	281008HB	5700	.40	30
.375	281010HB	8800	.70	20
.50	281013HB	15000	1.50	1
.625	281016HB	22600	2.50	1

¹Design factor is 4 to 1.

DIMENSIONS (IN)

A	B	C	D	E	LU
.28125	.4375	.50	.625	.6875	1.75
.50	.625	.6875	.8125	.875	2.1875
.5625	.75	.875	1.00	1.125	2.6875
.75	1.00	1.00	1.1875	1.375	3.75
.875	1.125	1.25	1.4375	1.625	4.0625



WARNING: Misuse of rigging equipment can result in serious injury up to and including loss of life. Only competent trained professionals should use Skookum products. Thoroughly inspect all equipment before each and every use and never use damaged or worn products. Skookum disclaims any liability resulting from the misuse of its products. Please take a moment to carefully review our maintenance and warnings page for more information.

Link Products



Link Products

WARNING: Improper use of Links can result in serious bodily injury, property damage and/or death. Only properly trained and competent persons are allowed to use links in a proper application. Never exceed working load limit. Always inspect before use for wear damage and elongation. Do not impact load. Apply load slowly and with caution. Protect from sharp corners and objects. Do not bend or force. Do not use on oversize crane hooks where link does not fit in saddle of the hook. Protect from corrosion.

CARE: Care shall be taken so that abuse such as bending or distortion does not occur. They shall not be used in extremely corrosive environments without protective coating such as galvanizing. Before galvanizing, to avoid altering metallurgy or heat treatment, contact Skookum for instructions. Improper processing or use voids all working load ratings. If subjected to high temperatures the load rating shall be temporarily or permanently derated.

INSPECTION: Before use, inspect the link for wear, bending, elongation, collapse, cracks, corrosion damage, nicks and gouges. Immediately remove from service if any of these conditions are found.

NOTES:

1. Links which are worn more than 5% of the original diameter shall be removed from service with proper disposal as referenced in Note 6.
2. Corrosion will deteriorate link material. Unless corrosion is very granular, apply wear criterion in Note 1 to determine if link must be removed from service. Any link with granular corrosion shall be removed from service with proper disposal as referenced in Note 6.
3. Wear criterion in Note 1 shall be applied to nicks and gouges.
4. Any bend in the link at inspection shall result in the link being removed from service with proper disposal as referenced in Note 6.
5. Links visibly distorted or twisted shall be removed from service with proper disposal as referenced in Note 6.
6. Any link discarded or removed from service shall be destroyed in a permanent manner such as cutting the link in half to ensure no possible future use.

LINKS PART NUMBER DECODER

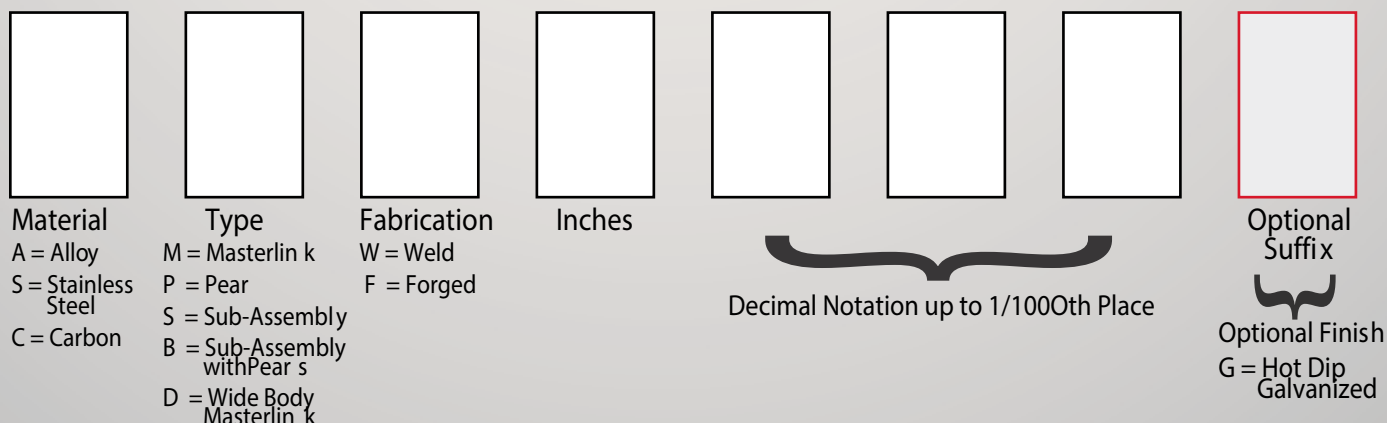

NOTE: Standard Finish is Painted Skookum® Orange

Masterlink Products

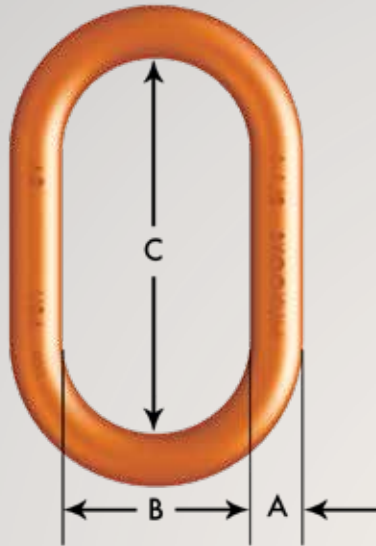

Masterlink

- Alloy Steel with Orange Finish
- Quenched & Tempered
- Individual Proof Test Certification* with each link
- Proof test fixture design prevents localized point loading per ASTM A952
- All links marked with material heat code for traceability, size, SKOOKUM, USA and A8 to signify grade 80
- Links 1½" and smaller are drop forged
- Links 1¾" and larger are robotically welded

SPECIFICATIONS

SIZE IN (A)	SIZE MM (A)	PART #	WEIGHT (LBS)	WLL 5:1 (TONS)	WLL 4:1 (TONS)
1/2"	13.00	AMF0500	0.80	3.50	4.38
5/8"	16.00	AMF0625	1.50	4.50	5.63
3/4"	19.00	AMF0750	2.10	6.15	7.69
1"	26.00	AMF1000	4.90	12.18	15.23
1-1/4"	32.00	AMF1250	9.60	19.55	24.44
1-1/2"	38.00	AMF1500	16.20	31.15	38.94
1-3/4"	44.00	AMW1750	25.20	42.45	53.06
2"	51.00	AMW2000	37.00	51.30	64.13
2-1/4"	57.00	AMW2250	54.10	71.55	89.44
2-1/2"	63.00	AMW2500	67.80	80.00	100.00
2-3/4"	70.00	AMW2750	87.70	108.45	135.56
3"	76.00	AMW3000	115.00	114.00	142.50
3-1/2"	89.00	AMW3500	200.00	139.50	174.38
4"	102.00	AMW4000	228.00	186.50	233.13
4-1/2"	114.00	AMW4500	345.00	180.00	225.00
5"	127.00	AMW5000	516.00	197.50	246.88
5-1/2"	140.00	AMW5500	675.00	247.95	309.94
6"	152.00	AMW6000	875.00	303.05	378.81
6-1/2"	165.00	AMW6500	1114.00	385.70	482.13
7"	178.00	AMW7000	1390.00	413.25	516.56

DIMENSIONS (IN)

A	B	C	
0.50	2.50	5.00	Forged
0.63	3.00	6.00	Forged
0.75	2.75	5.50	Forged
1.00	3.50	7.00	Forged
1.25	4.38	8.75	Forged
1.50	5.25	10.50	Forged
1.75	6.00	12.00	Welded
2.00	7.00	14.00	Welded
2.25	8.00	16.00	Welded
2.50	8.00	16.00	Welded
2.75	9.50	16.00	Welded
3.00	9.00	18.00	Welded
3.50	12.00	24.00	Welded
4.00	10.00	20.00	Welded
4.50	14.00	28.00	Welded
5.00	15.00	30.00	Welded
5.50	16.00	32.00	Welded
6.00	18.00	36.00	Welded
6.50	20.00	40.00	Welded
7.00	21.00	42.00	Welded

Skookum Master Links are available in any diameter and any size. Please contact us for any custom product or non-standard sizes.

*Sizes 3-1/2" and above are proof tested at customer request only a certificate of conformance is still provided.

WARNING: Misuse of rigging equipment can result in serious injury up to and including loss of life. Only competent trained professionals should use Skookum products. Thoroughly inspect all equipment before each and every use and never use damaged or worn products. Skookum disclaims any liability resulting from the misuse of its products. Please take a moment to carefully review our maintenance and warnings page for more information.

Masterlink Products

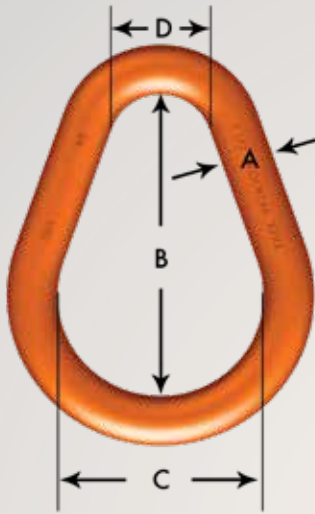

Pear Link

- Alloy Steel with Orange Finish
- Quenched & Tempered
- Individual Proof Test Certification* with each link
- All links marked with material heat code for traceability, size, SKOOKUM, USA and A8 to signify grade 80
- Links 1" and smaller are drop forged
- Links 1 1/4" and larger are robotically welded

SPECIFICATIONS

SIZE IN	SIZE MM	PART #	WEIGHT (LBS)	WLL 5:1 (TONS)	WLL 4:1 (TONS)
1/2"	13.00	APF0500	0.50	3.50	4.38
5/8"	16.00	APF0625	1.00	4.50	5.63
3/4"	19.00	APF0750	1.80	6.15	7.69
7/8"	22.00	APF0875	2.90	7.50	9.38
1"	25.00	APF1000	4.40	12.18	15.23
1-1/4"	32.00	APW1250	8.25	19.55	24.44
1-3/8"	35.00	APW1375	11.25	21.50	26.88
1-1/2"	38.00	APW1500	14.25	27.15	33.94
1-5/8"	41.00	APW1625	18.50	31.30	39.13
1-3/4"	44.00	APW1750	22.50	42.45	53.06
2"	51.00	APW2000	34.00	51.30	64.13
2-1/4"	57.00	APW2250	48.00	71.55	89.44
2-1/2"	63.00	APW2500	66.00	80.00	100.00
2-3/4"	70.00	APW2750	88.00	108.45	135.56
3"	76.00	APW3000	114.00	114.00	142.50
3-1/2"	89.00	APW3500	181.00	139.50	174.38
4"	102.00	APW4000	271.00	186.50	233.13
4-1/2"	114.00	APW4500	385.00	180.00	225.00
5"	127.00	APW5000	527.00	197.50	246.88
5-1/2"	138.00	APW5500	701.00	247.95	309.94
6"	152.00	APW6000	911.00	303.05	378.81
6-1/2"	165.00	APW6500	1158.00	385.70	482.13
7"	178.00	APW7000	1446.00	413.25	516.56

DIMENSIONS (IN)

A		B	C	D	
IN	MM				
0.50	13.00	3.00	2.00	1.00	Forged
0.63	16.00	3.75	2.50	1.25	Forged
0.75	19.00	4.50	3.00	1.50	Forged
0.88	22.00	5.25	3.50	1.75	Forged
1.00	25.00	6.00	4.00	2.00	Forged
1.25	32.00	7.50	5.00	2.50	Welded
1.38	35.00	8.25	5.50	2.75	Welded
1.5	38.00	9.00	6.00	3.00	Welded
1.63	41.00	9.75	6.50	3.25	Welded
1.75	44.00	10.50	7.00	3.50	Welded
2.00	51.00	12.00	8.00	4.00	Welded
2.25	57.00	13.50	9.00	4.50	Welded
2.50	63.00	15.00	10.00	5.00	Welded
2.75	70.00	16.50	11.00	5.50	Welded
3.00	76.00	18.00	12.00	6.00	Welded
3.50	89.00	21.00	14.00	7.00	Welded
4.00	102.00	24.00	16.00	8.00	Welded
4.5	114.00	27.00	18.00	9.00	Welded
5.00	127.00	30.00	20.00	10.00	Welded
5.50	138.00	33.00	22.00	11.00	Welded
6.00	152.00	36.00	24.00	12.00	Welded
6.50	165.00	39.00	26.00	13.00	Welded
7.00	178.00	42.00	28.00	14.00	Welded

Skookum Master Links are available in any diameter and any size. Please contact us for any custom product or non-standard sizes.

*Sizes 3-1/2" and above are proof tested at customer request only a certificate of conformance is still provided.



WARNING: Misuse of rigging equipment can result in serious injury up to and including loss of life. Only competent trained professionals should use Skookum products. Thoroughly inspect all equipment before each and every use and never use damaged or worn products. Skookum disclaims any liability resulting from the misuse of its products. Please take a moment to carefully review our maintenance and warnings page for more information.

Masterlink Products

Sub-Assembly MasterLink



- Alloy Steel with Orange Finish
- Quenched & Tempered
- Individual Proof Test Certification* with each link
- All links marked with material heat code for traceability, size, SKOOKUM, USA and A8 to signify grade 80
- Links 1½" and smaller are drop forged
- Links 1¾" and larger are robotically welded

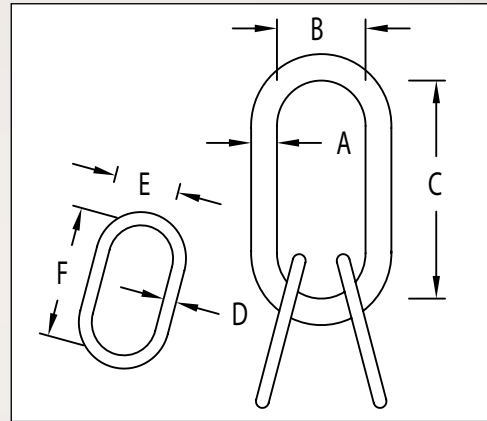

SPECIFICATIONS

SIZE IN	SIZE MM	PART #	WEIGHT (LBS)	WLL 5:1 (TONS)	WLL 4:1 (TONS)
1"	25.00	ASW1000	12.00	12.18	15.23
1-1/4"	32.00	ASW1250	20.00	19.55	24.44
1-1/2"	38.00	ASW1500	36.00	27.15	33.94
1-3/4"	44.00	ASW1750	58.00	42.45	53.06
2"	51.00	ASW2000	69.00	51.30	64.13
2-1/2"	63.00	ASW2500	142.00	80.00	100.00
2-3/4"	70.00	ASW2750	196.00	108.45	135.56
3"	76.00	ASW3000	251.00	114.00	142.50
3-1/2"	89.00	ASW3500	375.00	139.50	174.38
4"	102.00	ASW4000	404.00	186.50	233.13
4-1/2"	114.00	ASW4500	575.00	180.00	225.00
5"	127.00	ASW5000	916.00	197.50	246.88
5-1/2"	140.00	ASW5500	1131.00	247.95	309.94
6"	152.00	ASW6000	1565.00	303.05	378.81

DIMENSIONS (IN)

A	B	C	D	E	F
1.00	3.50	7.00	0.75	2.75	5.50
1.25	4.38	8.75	1.00	3.50	7.00
1.50	5.25	10.50	1.25	4.38	8.75
1.75	6.00	12.00	1.50	5.25	10.50
2.00	7.00	14.00	1.50	5.25	10.50
2.50	8.00	16.00	2.00	7.00	14.00
2.75	9.50	16.00	2.25	8.00	16.00
3.00	9.00	18.00	2.50	8.00	16.00
3.50	12.00	24.00	2.75	9.50	16.00
4.00	10.00	20.00	2.75	9.50	16.00
4.50	14.00	28.00	3.00	9.00	18.00
5.00	15.00	30.00	3.50	12.00	24.00
5.50	16.00	32.00	4.00	10.00	20.00
6.00	18.00	36.00	4.50	14.00	28.00

Skookum Master Links are available in any diameter and any size. Please contact us for any custom product or non-standard sizes.

*Sizes 3-1/2" and above are proof tested at customer request only a certificate of conformance is still provided.

WARNING: Misuse of rigging equipment can result in serious injury up to and including loss of life. Only competent trained professionals should use Skookum products. Thoroughly inspect all equipment before each and every use and never use damaged or worn products. Skookum disclaims any liability resulting from the misuse of its products. Please take a moment to carefully review our maintenance and warnings page for more information.

Masterlink Products



Sub-Assembly Pear Link

- Alloy Steel with Orange Finish
- Quenched & Tempered
- Individual Proof Test Certification* with each link
- All links marked with material heat code for traceability, size, SKOOKUM, USA and A8 to signify grade 80
- Pear Links 1" and smaller are drop forged
- Pear Links 1 1/4" and larger are robotically welded

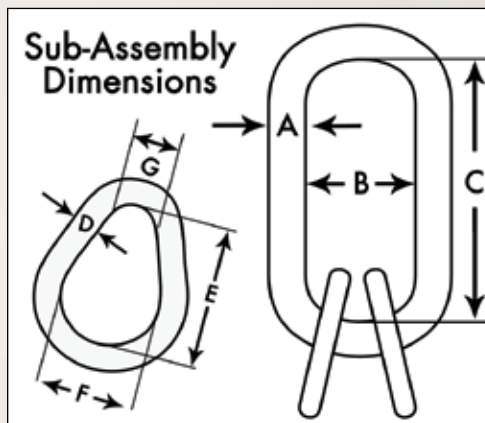

SPECIFICATIONS

SIZE IN	SIZE MM	PART #	WEIGHT (LBS)	WLL 5:1 (TONS)	WLL 4:1 (TONS)
1-1/2"	38.00	ABW1500	33.00	27.15	33.94
1-3/4"	44.00	ABW1750	54.00	42.45	53.06
2"	51.00	ABW2000	66.00	51.30	64.13
2-1/2"	63.00	ABW2500	136.00	80.00	100.00
2-3/4"	70.00	ABW2750	184.00	108.45	135.56
3"	76.00	ABW3000	247.00	114.00	142.50
3-1/2"	89.00	ABW3500	376.00	139.50	174.38
4"	102.00	ABW4000	404.00	186.50	233.13
4-1/2"	114.00	ABW4500	573.00	180.00	225.00
5"	127.00	ABW5000	878.00	197.50	246.88
5-1/2"	140.00	ABW5500	1217.00	247.95	309.94
6"	152.00	ABW6000	1645.00	303.05	378.81

DIMENSIONS (IN)

A	B	C	D	E	F	G	
1.50	5.25	10.50	1.25	7.50	5.00	2.50	Forged
1.75	6.00	12.00	1.50	9.00	6.00	3.00	Welded
2.00	7.00	14.00	1.50	9.00	6.00	3.00	Welded
2.50	8.00	16.00	2.00	12.00	8.00	4.00	Welded
2.75	9.50	16.00	2.25	13.50	9.00	4.50	Welded
3.00	9.00	18.00	2.50	15.00	10.00	5.00	Welded
3.50	12.00	24.00	2.75	16.50	11.00	5.50	Welded
4.00	10.00	20.00	2.75	16.50	11.00	5.50	Welded
4.50	14.00	28.00	3.00	18.00	12.00	6.00	Welded
5.00	15.00	30.00	3.50	21.00	14.00	7.00	Welded
5.50	16.00	32.00	4.00	24.00	16.00	8.00	Welded
6.00	18.00	36.00	4.50	27.00	18.00	9.00	Welded

Skookum Master Links are available in any diameter and any size. Please contact us for any custom product or non-standard sizes.

*Sizes 3-1/2" and above are proof tested at customer request only a certificate of conformance is still provided.



WARNING: Misuse of rigging equipment can result in serious injury up to and including loss of life. Only competent trained professionals should use Skookum products. Thoroughly inspect all equipment before each and every use and never use damaged or worn products. Skookum disclaims any liability resulting from the misuse of its products. Please take a moment to carefully review our maintenance and warnings page for more information.

Forestry Products



#109 Knock Out Pin Shackle
Item Located on Page 79

101 Screw Pin Shackle

With 1/8" oversize screw pin; most commonly used shackle for general rigging

PART NO.	SIZE (S)	WLL (TONS)	P	J	B	R	WEIGHT (LBS)
610105	5/8"	6.00	0.75	0.88	1.38	2.25	1.50
610106	3/4"	9.00	0.88	1.00	1.63	2.75	2.50
610107	7/8"	12.00	1.00	1.13	1.75	3.00	3.50
610108	1"	16.00	1.13	1.25	2.00	3.25	4.50
610109	1 1/8"	18.00	1.25	1.38	2.13	3.50	6.00
610110	1 1/4"	21.00	1.38	1.50	2.25	4.00	8.00
610111	1 3/8"	26.00	1.50	1.63	2.63	4.50	11.00
610112	1 1/2"	31.00	1.63	1.75	2.88	5.00	15.00
610113	1 5/8"	35.00	1.75	1.88	3.13	5.25	19.00
610114	1 3/4"	41.00	2.00	2.25	3.25	6.00	21.00
610116	2"	52.00	2.25	2.50	3.63	6.50	30.00

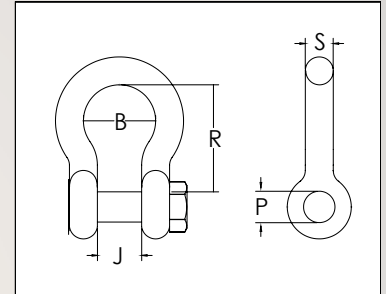

102 Bolt Type Shackle

Same bale configuration as above #101; pin is complete with nut and molly hole. This shackle is frequently referred to as a **Bolt Type** pin shackle.

PART NO.	SIZE (S)	WLL (TONS)	P	J	B	R	WEIGHT (LBS)
610205	5/8"	6.00	0.75	0.88	1.38	2.25	2.00
610206	3/4"	9.00	0.88	1.00	1.63	2.75	2.50
610207	7/8"	12.00	1.00	1.13	1.75	3.00	4.50
610208	1"	16.00	1.13	1.25	2.00	3.25	5.00
610209	1 1/8"	18.00	1.25	1.38	2.13	3.20	7.00
610210	1 1/4"	21.00	1.38	1.50	2.25	4.00	9.00
610211	1 3/8"	26.00	1.50	1.63	2.63	4.50	12.00
610212	1 1/2"	31.00	1.63	1.75	2.88	5.00	16.00
610213	1 5/8"	35.00	1.75	1.88	3.13	5.25	20.00
610214	1 3/4"	41.00	2.00	2.25	3.25	6.00	23.00
610216	2"	52.00	2.25	2.50	3.63	6.50	35.00

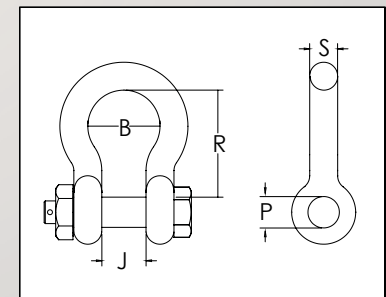

Skookum Forest products are designed to be used with and tested with Wire Rope conforming to the following description:

- New 6 x 19 or 6 x 37 Class, EIP, IWRC, Right Regular Lay Wire Rope made to US specifications.
- Used for Logging / Skidding or Pulling Applications
- NOT FOR OVERHEAD LIFTING



WARNING: Misuse of rigging equipment can result in serious injury up to and including loss of life. Only competent trained professionals should use Skookum products. Thoroughly inspect all equipment before each and every use and never use damaged or worn products. Skookum disclaims any liability resulting from the misuse of its products. Please take a moment to carefully review our maintenance and warnings page for more information.

105 Straight Side / Screw Pin Shackle

SPECIFICATIONS DIMENSIONS (IN)

PART NO.	SIZE (S)	WLL (TONS)	WEIGHT (LBS)	P	J	R
610504	1/2"	4.00	1.00	0.63	0.75	2.25
610505	5/8"	6.00	1.50	0.75	0.88	2.50
610506	3/4"	9.00	2.50	0.88	1.00	2.75
610507	7/8"	12.00	3.50	1.00	1.13	3.00
610508	1"	16.00	4.50	1.13	1.25	3.50
610509	1 1/8"	18.00	6.00	1.25	1.38	3.75
610510	1 1/4"	21.00	8.00	1.38	1.50	4.25
610511	1 3/8"	26.00	10.00	1.50	1.63	5.00
610512	1 1/2"	31.00	15.00	1.63	1.75	5.50
610514	1 3/4"	41.00	21.00	2.00	2.25	6.00

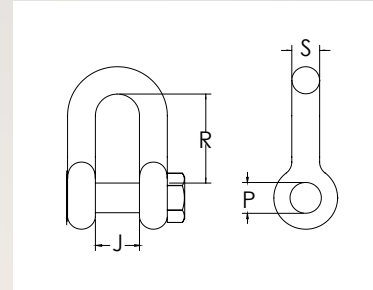

106 Straight Side / Bolt Type Shackle

With nut and molly hole

PART NO.	SIZE (S)	WLL (TONS)	WEIGHT (LBS)	P	J	R
610604	1/2"	4.00	1.5	0.63	0.75	2.25
610605	5/8"	6.00	2	0.75	0.88	2.50
610606	3/4"	9.00	2.5	0.88	1.00	2.75
610607	7/8"	12.00	3.5	1.00	1 1/8"	3.00
610608	1"	16.00	4.5	1.13	1.25	3.50
610609	1 1/8"	18.00	6	1.25	1.38	3.75
610610	1 1/4"	21.00	8	1.38	1.50	4.50
610611	1 3/8"	26.00	10	1.50	1.63	5.00
610612	1 1/2"	31.00	15	1.63	1.75	5.50
610614	1 3/4"	41.00	21	2.00	2.25	6.00
610616	2"	52.00	30	2.25	2.50	6.50

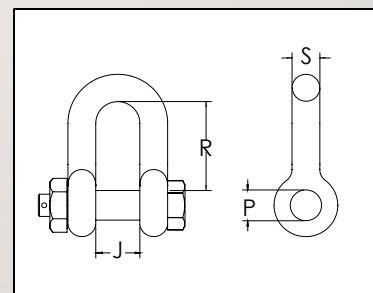

Skookum Forest products are designed to be used with and tested with Wire Rope conforming to the following description:

- New 6 x 19 or 6 x 37 Class, EIP, IWRC, Right Regular Lay Wire Rope made to US specifications.
- Used for Logging / Skidding or Pulling Applications
- NOT FOR OVERHEAD LIFTING

WARNING: Misuse of rigging equipment can result in serious injury up to and including loss of life. Only competent trained professionals should use Skookum products. Thoroughly inspect all equipment before each and every use and never use damaged or worn products. Skookum disclaims any liability resulting from the misuse of its products. Please take a moment to carefully review our maintenance and warnings page for more information.

108 Hanging Shackle

Bale has a deep spread with a wide bell. Pin is secured with a jam nut and molly hole.

PART NO.	SIZE (S)	WLL (TONS)	P	J	B	R	WEIGHT (LBS)
610805	5/8"	6.00	0.75	0.88	2.00	3.00	3.50
610806	3/4"	9.00	0.88	1.00	2.38	3.50	4.00
610807	7/8"	12.00	1.00	1.13	2.63	4.00	4.50
610808	1"	16.00	1.13	1.25	3.00	5.00	6.00
610809	1 1/8"	18.00	1.25	1.38	3.25	5.50	7.50
610810	1 1/4"	21.00	1.38	1.50	3.75	6.00	10.00
610811	1 3/8"	26.00	1.50	1.63	4.00	6.50	15.00
610812	1 1/2"	31.00	1.63	1.75	4.25	7.00	17.00
610813	1 5/8"	35.00	1.75	1.88	4.63	7.50	21.00
610814	1 3/4"	41.00	2.00	2.25	5.00	8.00	28.00
610816	2"	52.00	2.25	2.50	5.50	8.50	37.00

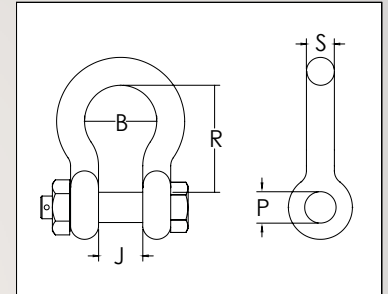

109 Knock Out Pin Shackle

Complete with #108 Shackle bale

PART NO.	SIZE (S)	WLL (TONS)	P	J	B	R	WEIGHT (LBS)
610906	3/4"	9.00	0.88	1.00	2.38	3.50	3.50
610907	7/8"	12.00	1.00	1.13	2.63	4.00	4.00
610908	1"	16.00	1.13	1.25	3.00	5.00	6.00
610909	1 1/8"	18.00	1.25	1.38	3.25	5.50	7.50
610910	1 1/4"	21.00	1.38	1.50	3.75	6.00	10.00
610911	1 3/8"	26.00	1.50	1.63	4.00	6.50	15.00
610912	1 1/2"	31.00	1.63	1.75	4.25	7.00	17.00
610913	1 5/8"	35.00	1.75	1.88	4.63	7.50	21.00
610914	1 3/4"	41.00	2.00	2.25	5.00	8.00	28.00
610916	2"	52.00	2.25	2.50	5.50	8.50	37.00

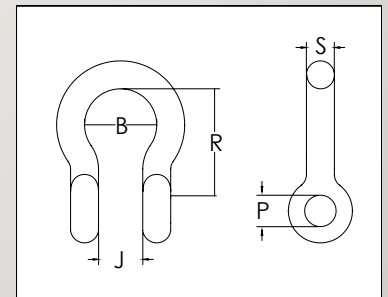

109 Knock Out Pin

Pin Only



PART NO.	DIAM.	WEIGHT (LBS)
109006	7/8"	1.10
109007	1"	1.60
109008	1 1/8"	2.10
109009	1 1/4"	3.00
109010	1 3/8"	4.40
109011	1 1/2"	5.00
109012	1 5/8"	5.70
109013	1 3/4"	7.00

Skookum Forest products are designed to be used with and tested with Wire Rope conforming to the following description:

- New 6 x 19 or 6 x 37 Class, EIP, IWRC, Right Regular Lay Wire Rope made to US specifications.
- Used for Logging / Skidding or Pulling Applications
- NOT FOR OVERHEAD LIFTING



WARNING: Misuse of rigging equipment can result in serious injury up to and including loss of life. Only competent trained professionals should use Skookum products. Thoroughly inspect all equipment before each and every use and never use damaged or worn products. Skookum disclaims any liability resulting from the misuse of its products. Please take a moment to carefully review our maintenance and warnings page for more information.

110 Flush Pin Shackle

Pin threads into the shackle, hole will accommodate a 1/2" drive

PART NO.	SIZE (S)	WLL (TONS)	P	J	R	WEIGHT (LBS)
611005	5/8"	6.00	0.75	1.00	2.25	1.50
611006	3/4"	9.00	0.88	1.00	1.88	2.00
611007	7/8"	12.00	1.00	1.13	2.00	2.50
611008	1"	16.00	1.13	1.25	2.25	4.10
611009	1 1/8"	18.00	1.25	1.38	2.75	5.00
611010	1 1/4"	21.00	1.38	1.50	3.25	7.00
611011	1 3/8"	26.00	1.50	1.63	4.00	10.00
611012	1 1/2"	31.00	1.63	1.75	4.25	11.00
611013	1 5/8"	32.00	1.75	1.88	4.63	14.00
611014	1 3/4"	41.00	2.00	2.25	5.00	17.00
611016	2"	52	2.25	2.50	6.00	28.00

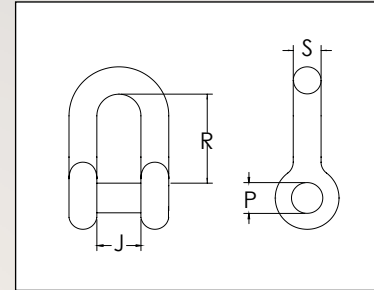

110S Flat Bottom / Flush Pin Shackle

Shackle Complete

PART NO.	SIZE (S)	WLL (TONS)	P	J	R	WEIGHT (LBS)
611056	3/4"	9.00	0.88	1.13	2.75	3.00
611057	7/8"	12.00	1.00	1.25	2.75	4.00
611058	1"	16.00	1.125	1.25	3.25	4.30

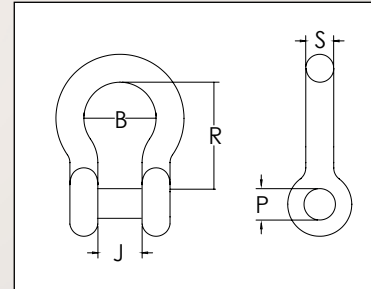

Flush Pin Roller available on request

PART NO.	SIZE (S)
110106	3/4"
110107	7/8"
110108	1"

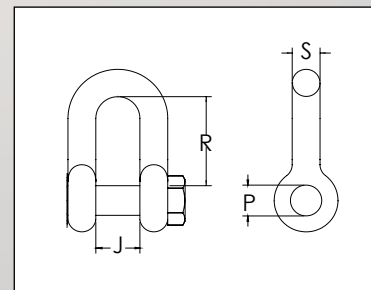
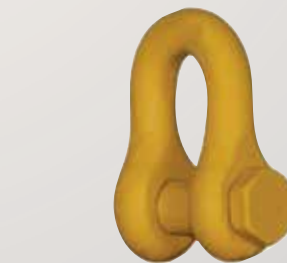

112 Arch Hook Shackle

Complete Shackle has a slight bell in the bale.

PART NO.	SIZE (S)	WLL (TONS)	P	J	B	R	WEIGHT (LBS)
611206	3/4"	9.00	0.88	1.00	1.13	1.88	2.00
611208	1"	16.00	1.13	1.25	1.38	2.25	4.50
611209	1 1/8"	18.00	1.25	1.38	1.50	2.38	6.00
611210	1 1/4"	21.00	1.38	1.50	1.63	2.75	8.00
611211	1 3/8"	26.00	1.50	1.63	1.75	3.00	12.00

SEE WARNING PAGE FOR IMPORTANT NOTE REGARDING FORESTRY PRODUCT RATINGS DETAIL

 **WARNING:** Misuse of rigging equipment can result in serious injury up to and including loss of life. Only competent trained professionals should use Skookum products. Thoroughly inspect all equipment before each and every use and never use damaged or worn products. Skookum disclaims any liability resulting from the misuse of its products. Please take a moment to carefully review our maintenance and warnings page for more information.

174 Butt Rigging Shackle

Shackle Complete with pin

PART NO.	SIZE (S)	P	J	R	WLL (TONS)	WEIGHT (LBS)
617406	3/4"	0.88	0.94	2.50	9.00	3.00
617407	7/8"	1.00	1.00	2.75	12.00	4.80
617408	1"	1.13	1.19	3.07	16.00	5.80
617409	1 1/8"	1.25	1.38	3.75	18.00	8.30
617410	1 1/4"	1.38	1.50	4.00	21.00	10.00
617411	1 3/8"	1.50	1.69	4.25	26.00	15.00
617412	1 1/2"	1.63	1.81	4.50	31.00	19.00
617413	1 5/8"	1.75	1.94	5.00	35.00	21.00
617414	1 3/4"	1.88	2.13	5.50	41.00	23.00

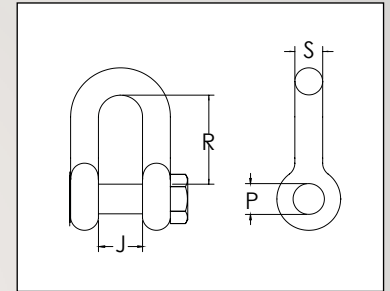

118i Intergal Swivel Buzzard Hook

PART NO.	SIZE	WEIGHT (LBS)
611811i	1 3/8"	12.00
611812i	1 1/2"	15.00
611814i	1 3/4"	17.00

Latch repair kit part #611711K



117 Buzzard Hook

PART NO.	LINE SIZE	SIZE	WEIGHT (LBS)
611711	1/2	1 3/8"	11.00
611712	5/8	1 1/2"	12.00
611714	3/4	1 3/4"	14.00
611716	7/8	2"	18.00
611718	1.00	2 1/4"	22.00
611720	1 1/8	2 1/2"	30.00

Latch repair kit part #611711K



Skookum Forest products are designed to be used with and tested with Wire Rope conforming to the following description:

- New 6 x 19 or 6 x 37 Class, EIP, IWRC, Right Regular Lay Wire Rope made to US specifications.
- Used for Logging / Skidding or Pulling Applications
- NOT FOR OVERHEAD LIFTING



WARNING: Misuse of rigging equipment can result in serious injury up to and including loss of life. Only competent trained professionals should use Skookum products. Thoroughly inspect all equipment before each and every use and never use damaged or worn products. Skookum disclaims any liability resulting from the misuse of its products. Please take a moment to carefully review our maintenance and warnings page for more information.

113 Cross Eye / (Reverse Eye)

T-Point Arch Hook

PART NO.	SIZE	LINE SIZE	SHACKLE SIZE	WEIGHT (LBS)
611310TP	1 1/4"	1/2	3/4	5.00
611312TP	1 1/2"	3/4	1	6.00
611313TP	1 5/8"	3/4	1	7.00
611314TP	1 3/4"	7/8	1 1/8	9.00
611315TP	1 7/8"	7/8	1 1/4	12.00
611316TP	2"	1	1 1/4	15.00
611317TP	2 1/8"	1	1 3/8	18.00
611318TP	2 1/4"	1 1/8	1 3/8	20.00
611320TP	2 1/2"	1 1/4	1 3/8	25.00



114 Straight Eye / (Regular Eye)

Arrow Point Arch Hook

PART NO.	SIZE	LINE SIZE	SHACKLE SIZE	SHACKLE PART NO.	HOOK WEIGHT (LBS)
611410PP	1 1/4"	1/2	3/4	611410	5.50
611412PP	1 1/2"	3/4	1	611412	7.00
611414PP	1 3/4"	7/8	1 1/8	611414	10.00
611416PP	2"	1.00	1 1/4	611416	16.00
611418PP	2 1/4"	1 1/8	1 3/8	611418	22.00
611420PP	2 1/2"	1 1/4	1 3/8	611420	27.00



115 Line Hook (Cross Eye)

PART NO.	SIZE	LINE SIZE	HOLE SIZE	JAW OPENING	WEIGHT (LBS)
611506CE	3/4"	0.25	0.50	0.88	0.80
611507CE	7/8"	0.38	0.63	1.00	1.00
611508CE	1"	0.38	0.75	1.13	1.00
611509CE	1 1/8"	0.44	0.88	1.25	2.50
611510CE	1 1/4"	0.50	1.00	1.38	4.00
611511CE	1 3/8"	0.56	1.13	1.50	5.00
611512CE	1 1/2"	0.63	1.13	1.63	6.00
611514CE	1 3/4"	0.75	1.13	1.75	8.50



Skookum Forest products are designed to be used with and tested with Wire Rope conforming to the following description:

- New 6 x 19 or 6 x 37 Class, EIP, IWRC, Right Regular Lay Wire Rope made to US specifications.
- Used for Logging / Skidding or Pulling Applications
- NOT FOR OVERHEAD LIFTING

 **WARNING:** Misuse of rigging equipment can result in serious injury up to and including loss of life. Only competent trained professionals should use Skookum products. Thoroughly inspect all equipment before each and every use and never use damaged or worn products. Skookum disclaims any liability resulting from the misuse of its products. Please take a moment to carefully review our maintenance and warnings page for more information.

115 Line Hook (Straight Eye)

PART NO.	SIZE	LINE SIZE	HOLE SIZE	JAW OPENING	WEIGHT (LBS)
611506SE	3/4"	0.25	0.50	0.88	0.80
611507SE	7/8"	0.38	0.63	1.00	1.00
611508SE	1"	0.38	0.75	1.13	1.00
611509SE	1 1/8"	0.44	0.88	1.25	2.50
611510SE	1 1/4"	0.50	1.00	1.38	4.00
611511SE	1 3/8"	0.56	1.13	1.50	5.00
611512SE	1 1/2"	0.63	1.13	1.63	6.00
611514SE	1 3/4"	0.75	1.13	1.75	8.50



116 Flat Choker Hook

Order by Line Size. Intended for regular wire rope, not swaged wire rope.

PART NO.	LINE SIZE	SIZE	HOLE SIZE	WEIGHT (LBS)
611603	3/8"	1/2 x 1 1/2	0.63	0.80
611604	1/2"	5/8 x 2	0.69	1.00
611605	5/8"	3/4 x 2	0.75	2.00
611606	3/4"	7/8 x 2 1/2	0.88	3.00
611607	7/8"	1 x 3	1.00	5.00
611608	1"	1 1/8 x 3 1/2	1.13	7.00
611609	1 1/8"	1 1/4 x 4	1.25	10.00
611610	1 1/4"	1 1/2 x 5	1.50	15.00



125 Skidding Tongs

PART NO.	SIZE	SPREAD	WEIGHT (LBS)
612507	7/8"	14"	14.00
612508	1"	16"	16.00
612509	1 1/8"	20"	20.00
612510	1 1/4"	24"	24.00
612512	1 1/2"	28"	28.00
612514	1 3/4"	32"	32.00



Skookum Forest products are designed to be used with and tested with Wire Rope conforming to the following description:

- New 6 x 19 or 6 x 37 Class, EIP, IWRC, Right Regular Lay Wire Rope made to US specifications.
- Used for Logging / Skidding or Pulling Applications
- NOT FOR OVERHEAD LIFTING



WARNING: Misuse of rigging equipment can result in serious injury up to and including loss of life. Only competent trained professionals should use Skookum products. Thoroughly inspect all equipment before each and every use and never use damaged or worn products. Skookum disclaims any liability resulting from the misuse of its products. Please take a moment to carefully review our maintenance and warnings page for more information.

126 Guyline Sleeve With Bolt & Nut

Includes #102 safety pin

PART NO.	SIZE	WEIGHT (LBS)
612607	7/8"	8.00
612608	1"	11.00
612609	1 1/8"	15.00
612610	1 1/4"	18.00
612611	1 3/8"	25.00
612612	1 1/2"	27.00
612613	1 5/8"	33.00
612614	1 3/4"	38.00



128 Splicing Hammer

PART NO.	SIZE/TYPE
612803	3# Without Handle
612813	3# With Handle
612804	4# Without Handle
612814	4# With Handle



146 Sledge Hammer

PART NO.	WEIGHT (LBS)
614606	6# Without Handle
614607	6# With Handle
614608	8# Without Handle
614609	8# With Handle
614610	10# Without Handle
614611	10# With Handle
614612	12# Without Handle
614613	12# With Handle



Skookum Forest products are designed to be used with and tested with Wire Rope conforming to the following description:

- New 6 x 19 or 6 x 37 Class, EIP, IWRC, Right Regular Lay Wire Rope made to US specifications.
- Used for Logging / Skidding or Pulling Applications
- NOT FOR OVERHEAD LIFTING

WARNING: Misuse of rigging equipment can result in serious injury up to and including loss of life. Only competent trained professionals should use Skookum products. Thoroughly inspect all equipment before each and every use and never use damaged or worn products. Skookum disclaims any liability resulting from the misuse of its products. Please take a moment to carefully review our maintenance and warnings page for more information.

137 Strawline Swivel

PART NO.	SIZE	WEIGHT (LBS)
613775	3/8" - 7/16"	0.80



131 Strawline Hook

PART NO.	LINE SIZE
613104	1/4"
613105	5/16"
613106	3/8"
613107	7/16"
613108	1/2"



178 Line Swivel

PART #	LINE SIZE
617804	1/2"
617805	5/8"
617806	3/4"
617808	1"
617809	1 1/8"



151 Trailer Loading Hook

With 1in #108 Shackle

PART NO.	TON	SIZE	WEIGHT (LBS)
615112	8 Ton	1 1/2"	19.00
615114	11 Ton	1 3/4"	24.00

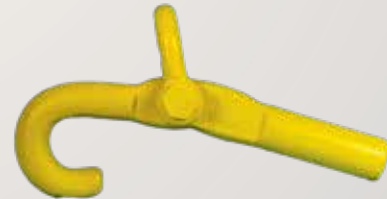

154 Dropline Socket

PART NO.	SIZE	HOOK	PIN DIAM.
154066	5/8" - 3/4"	1.38	0.88
154067	3/4" - 7/8"	1.50	1.00
154068	7/8" - 1"	1.75	1.13



Skookum Forest products are designed to be used with and tested with Wire Rope conforming to the following description:

- New 6 x 19 or 6 x 37 Class, EIP, IWRC, Right Regular Lay Wire Rope made to US specifications.
- Used for Logging / Skidding or Pulling Applications
- NOT FOR OVERHEAD LIFTING



WARNING: Misuse of rigging equipment can result in serious injury up to and including loss of life. Only competent trained professionals should use Skookum products. Thoroughly inspect all equipment before each and every use and never use damaged or worn products. Skookum disclaims any liability resulting from the misuse of its products. Please take a moment to carefully review our maintenance and warnings page for more information.

152 Splitting Froe

PART NO.	SIZE	WEIGHT (LBS)
615218	18" Froe With Handle	8.00



158 Aluminum Head Froe Hammer

PART NO.	WEIGHT (LBS)
615810	10.00



120 Alloy Rings

PART NO.	SIZE ID	WLL (TONS)	WEIGHT (LBS)
612004	1/2" x 2 3/4"	1.25	0.80
612005	5/8" x 3"	2.00	1.00
612006	3/4" x 3 1/2"	3.50	1.80
612007	7/8" x 3 3/4"	5.00	2.50
612008A	1" x 4"	6.00	3.50
612008B	1" x 4 1/2"	6.00	3.80
612009	*1 1/8" x 4 3/4"	6.50	5.30
612010	*1 1/4" x 5"	7.00	7.00



* Welded

Marlin Spikes

PART NO.	LENGTH	PART NO.	LENGTH
650106	6"	650118	18"
650108	8"	650120	20"
650110	10"	650124	24"
650112	12"	650130	30"
650114	14"	650136	36"
650116	16"	650142	42"



Skookum Forest products are designed to be used with and tested with Wire Rope conforming to the following description:

- New 6 x 19 or 6 x 37 Class, EIP, IWRC, Right Regular Lay Wire Rope made to US specifications.
- Used for Logging / Skidding or Pulling Applications
- NOT FOR OVERHEAD LIFTING

 **WARNING:** Misuse of rigging equipment can result in serious injury up to and including loss of life. Only competent trained professionals should use Skookum products. Thoroughly inspect all equipment before each and every use and never use damaged or worn products. Skookum disclaims any liability resulting from the misuse of its products. Please take a moment to carefully review our maintenance and warnings page for more information.

“Clark” Swivels

Use With Ulven #114 Hook

PART NO.	SIZE	LINE SIZE	HOOK
501207	C-7	3/4"	1 3/4"
501209	C-9	7/8"	2"



Double Ender Hooks

PART NO.	SIZE	LINE SIZE
501010	Bantam	5/8 x 3/4
501000	Junior	7/8 x 1 3/4
501020	Standard	1 x 1 1/2



#31 SKM RR Car Hook

PART NO.	WLL (TONS)	A	B	C	D	E	F	G	LINE SIZE	WEIGHT (LBS)
312069	25.00	1.50	12.25	3.00	7.75	1.81	2.56	3.13	1.50	23.50
312068	20.00	1.38	12.00	3.00	7.75	1.69	2.56	3.50	1.38	20.00



Drawbar Protector Arcs

SIZE	STOCK NO.	WEIGHT (LBS)
1/2"	DB1960	17.00
9/16"	DB1970	18.00
5/8"	DB1980	20.00
3/4"	DB1990	27.00
7/8"	DB2000	38.00
1"	DB2010	45.00
1-1/8"	DB2020	50.00

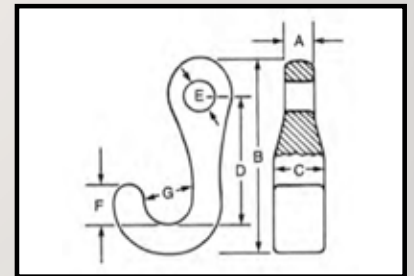

Skookum Forest products are designed to be used with and tested with Wire Rope conforming to the following description:

- New 6 x 19 or 6 x 37 Class, EIP, IWRC, Right Regular Lay Wire Rope made to US specifications.
- Used for Logging / Skidding or Pulling Applications
- NOT FOR OVERHEAD LIFTING



WARNING: Misuse of rigging equipment can result in serious injury up to and including loss of life. Only competent trained professionals should use Skookum products. Thoroughly inspect all equipment before each and every use and never use damaged or worn products. Skookum disclaims any liability resulting from the misuse of its products. Please take a moment to carefully review our maintenance and warnings page for more information.

Car Wheel Hooks

TYPE	STOCK NO.	WLL* (TONS)	WEIGHT (LBS)
Standard	CWH2360	3.10	17.00
Heavy	CWH2390	4.10	24.00
Ex Heavy	CWH2400	8.00	27.00
Combination ¹	CWH2370	3.00	23.00

* 5:1 Design Factor when used in pairs



¹CWH2370

Car Puller Hooks

TYPE	STOCK NO.	WLL* (TONS)	WEIGHT (LBS)
#7	CPH2030	7.50	18.00
#8	CPH2040	12.50	22.00

* 5:1 Design Factor



Manhole Pins

PART NO.	SIZE	WLL* (TONS)
MH-3550	1 1/4	2.30
MH-3555	1 1/2	4.00
MH-3560	1 7/8	5.00

* WLL and 5:1 Design Factor require pins to be used in pairs



Skookum Forest products are designed to be used with and tested with Wire Rope conforming to the following description:

- New 6 x 19 or 6 x 37 Class, EIP, IWRC, Right Regular Lay Wire Rope made to US specifications.
- Used for Logging / Skidding or Pulling Applications
- NOT FOR OVERHEAD LIFTING



WARNING: Misuse of rigging equipment can result in serious injury up to and including loss of life. Only competent trained professionals should use Skookum products. Thoroughly inspect all equipment before each and every use and never use damaged or worn products. Skookum disclaims any liability resulting from the misuse of its products. Please take a moment to carefully review our maintenance and warnings page for more information.



Guaranteed Tough Since 1890

MAINTENANCE & WARNINGS

MAINTENANCE, INSPECTION AND WORKING LOAD CRITERIA FOR SKOOKUM GROUP OF HOISTING BLOCKS, FAIRLEADS, SHEAVES, AND FORGINGS. LUBRICATION AND SCHEDULES:

Before leaving our manufacturing facilities all parts that require grease are lubricated with multipurpose, polyurea petroleum based grease of medium consistency. This does not relieve the end user of their responsibility of periodic lubrication. The following is a general lubrication schedule. The frequency of inspection and lubrication should be based on the frequency of use, harshness of environment, climatic conditions, and the user's own maintenance and lubrication schedules.

SHEAVES AND ROLLER LUBRICATION:

Bronze Bushings:

(Non self-lubricating type) every 8 hours of normal continuous operation, twice a month for normal intermittent use, or monthly if seldom used.

(Self-lubricating type) this type of bushing should never be greased. A light oil reservoir system is recommended under severe conditions.

- Roller/Ball Bearings - Every 24 hours of normal continuous operation, twice a month for normal intermittent use, or monthly if seldom used.
- Tapered Roller Bearings - Every 40-48 hours of normal continuous operation, or once a month for intermittent use.

Thrust Bearings and Thrust Washer Lubrication:

- Thrust Bearings - Twice a month for frequent normal swiveling or every 3 weeks for intermittent normal swiveling and/or straight static loading.
- Bronze/Brass Thrust Washers - Once a day for frequent normal swiveling or every 3 weeks for intermittently normal swiveling and/or straight loading.

STORAGE CONDITIONS:

If parts have been stored outside without adequate cover, bearings (particularly Roller, Ball, or Tapered Bearings) should be checked monthly and lubricated to reduce the risk of corrosion between matching metal parts. Before initial startup of stored equipment, it is highly recommended that parts be cleaned and lubricated prior to use, regardless of the last scheduled lubrication period.

WORKING LOAD LIMITS:

All ratings shown in Skookum literature are based upon the item being new or in "as new" condition.

Catalog ratings are considered to be the greatest load that should be applied to the item. Therefore, abnormal loading must be taken into consideration when selecting the item for use in any system. Continuous rapid shock, or surge loading, i.e. high cycle loading will rapidly reduce the Working Load and the life of the product. These conditions require more frequent inspection and testing, including additional N.D.E. (Non-destructive testing/examination).

Catalog ratings are based upon typical environmental conditions. Consideration must be given to item selection when unusual conditions are to be encountered. All ratings are in U.S. short tons of 2,000 lb per Ton.

The products shown are to be used in a tension or straight pull manner. Caution must be used to prevent the product from being subjected to side loading conditions that would cause additional and/or unintended loading.

All hook latches are intended to retain loose slings or devices under slack conditions. They are not intended to be antifouling devices. Caution should be to prevent the latch from supporting any part of the load. Periodic inspection of latches must be made to insure a proper operating condition.

Grinding, welding, and/or weld repair of any of our products without written consent by our company voids all warranty, whether written or expressed. It is recommended that you contact our engineering department for consultation before attempting any type of repair by welding or grinding.

Line sizes expressed in our catalog refer to regular 6 x 19 construction wire rope, not swaged rope.

INSPECTION AND WEAR:

Wear, misuse, overloading, deformation, intentional alteration, and other usage factors may necessitate a reduction in the product's working load rating, or a reduction in its design factor rating. It is recommended that all products be inspected

MAINTENANCE & WARNINGS (cont.)

on a regular basis to determine their serviceability. It is necessary to clean and inspect all items on a regular basis and keep accurate records of the inspection. The minimum industry standard is daily visual inspection and a monthly written and recorded inspection. Things to look for and inspections to perform include (but are not limited to) the following:

- Marks, nicks, gouges, scuffing, and cracks.
- Wear, especially excessive wear at load bearing points and threaded parts.
- Twists or bends in forged shackles and hooks.
- Unauthorized grinding, welding, cutting, or high heating conditions
- Opening or stretching of hooks, shackles and links
- Loose or worn retaining latches on hooks
- Loose nuts, pins, or missing cotter/clip pins
- Mushroomed contact points on shackles, hooks, and striking faces on hammers and splitting devices.
- N.D.E. Inspection as warranted (non-destructive testing examination such as Magnetic Particle, Die Penetrant, Ultrasonic, and/or X-Ray)

Any item showing evidence of, or failing any of the above inspections should be immediately removed from service. Items may be returned to Skookum (freight prepaid) for professional inspection for a minimum charge. If the item cannot be reworked or repaired, or is in an unsafe condition, we will notify the customer immediately and make arrangements for the disposal of the item.

TYPES OF LOADS:

Knowing the correct terminology of the load ratings helps in specifying the correct item for your application. The following load definitions are the ones most commonly used in our industry:

Working Load or Working Load Limit

The maximum recommended load that should be applied on the item. The terms Working Load (WL) and Working Load Limit (WLL) refer to straight in-line pull with respect to the centerline of the item unless otherwise noted.

PROOF LOAD

The average load to which an item may be subjected to before visual or permanent deformation occurs. It also refers to a testing procedure where a load is applied in the performance of a proof test.

ULTIMATE LOAD

The weighted average load at which the item being tested fails or will no longer supports the load.

SHOCK LOAD

Is a resulting load caused by the rapid change of movement such as impacting or jerking of a static load. A shock load is typically significantly greater than the static load. In some cases it will double the static load instantaneously and should be avoided as both a potential hazard to equipment operators and to the equipment itself.

DESIGN FACTOR:

This is an Industry term denoting theoretical reserve capability. This is usually expressed as a ratio such as 4 to 1 or 5 to 1 (4:1 or 5:1). It is normally determined by dividing the rated ultimate strength by the stated working load limit (WLL). It may also be based as a weighted average (as per the ultimate load definition above), or as a minimum factor. In which case the ultimate tested load meets or exceeds the stated design factor.

Terms to be avoided or not to be used at all:

Safe Working Load or Resultant Safe Working Load are not accepted terminology and do not denote specific product capabilities. Working Load or Working Load Limit are the proper descriptors.

Safety Factor is not an accepted terminology. Design Factor is the proper descriptor.

IMPORTANT NOTE REGARDING FORESTRY PRODUCT RATINGS:

Skookum Forest products are designed to be used with and tested with Wire Rope conforming to the following description:

- New 6 x 19 or 6 x 37 Class, EIP, IWRC, Right Regular Lay Wire Rope made to US specifications.
- Used for Logging / Skidding or Pulling Applications
- NOT FOR OVERHEAD LIFTING

MAINTENANCE & WARNINGS (cont.)

SKOOKUM SHACKLES, RIGGING, AND BLOCKS

This guide covers the application and maintenance for the Skookum, B.C.M., RopeMaster, and Ulven Brand Shackles and Rigging. It also includes the Skookum and Ulven Brand Blocks and Rigging products.

SKOOKUM SHACKLES:

Skookum Shackles are Forged Alloy Steel, and meet or exceed the criteria of ASME B30.26, Chapter 26-1, and/or the Federal Specification RR-C-271.

DESIGN FACTOR:

The Design Factor on standard catalog Skookum Shackles are based on a minimum of 5 to 1 (5:1). The Design Factor (ultimate capacity) is arrived at under ideal and controlled conditions and should never be used as a basis for reverse design engineering.

WORKING LOAD (RATED LOAD):

The working load or rated load is the maximum load that should be exerted on the item.

PROOF TESTING:

Proof testing is completed per customer request and/or at Skookum's discretion. As a rule, proofing of Skookum shackles requires testing at twice the stated Working Load Limit (WLL), or as required by ASME B30.26, Chapter 26-1, or in accordance with the RR-C-271. In some cases, the standard Skookum proof test exceeds both of these specifications and Skookum should be consulted with any special proof test requirements.

Standard process on all RR-C-271 proof testing shall be single point loading. All other Proof Tests shall fill up to 80% of the jaw width to properly center the load on the pin. It is recommended that spacers or washers be used to center the load during normal operations so no accidental side loading occurs.

See Figure SL-001.1 for recommendations using Skookum Shackles with Slings.

See Figure SL-001.2 side loaded reduction table for pad eye configuration. In all cases the pad eye width should be at least 80% of the Jaw width.

For special testing purposes such as periodic Magnetic Particle Inspection after proof testing see below for maximum percentage allowances for removing tooling/forging marks/ and minor indications. If grinding exceeds these percentages parts should be removed from service and Skookum Engineering should be consulted.

MAXIMUM CLEAN UP ALLOWED BY GRINDING FOR MPI PURPOSES

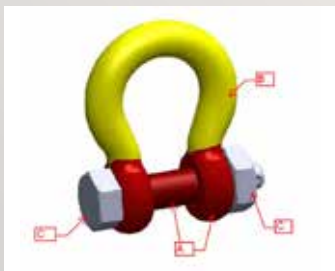

The following are maximum percentages of removal allowed if grinding out minor linear indications found during MPI testing.

- A. 3% to 4% Off of Catalog Dimensions
- B. 6% to 8% Off of Catalog Dimensions
- C. 15% to 20% On Non-Load Areas

SIDE LOADED REDUCTION TABLE FOR PAD EYE USAGE

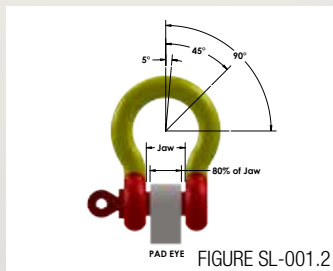

Angled loads must be applied in the plane of the Shackle Bow.

Side loading reduction Chart for Screw Pin and Bolt Type Shackles Only	
SIDE LOADING ANGLE (DEG)	% RATE LOAD REDUCTION
In-line 0° to 5°	None
6° to 45°	30%
46° to 90°	50%
Over 90°	Not recommended to load in this condition. Consult manufacturer or qualified person.
* In-Line Load is applied perpendicular to pin.	
** Never side load Round Pin Shackles.	
*** If angle exceeds 45° use a Bolt Type Shackle.	

For Shackles larger than 117 Tons, where the angle is greater than 5°, contact Skookum Engineering.

RECOMMENDATION USING SKOOKUM SHACKLES WITH SLINGS



Never exceed 120° Inclusive angle. Never use Round Pin Shackles.

Shackles symmetrically loaded with two legged slings having a maximum inclusive angle of 120° can be used to full rated Working Load Limit.

For Shackles larger than 117 Ton, the maximum angle is 90° for full working load limit. If inclusive angle is greater than 120°, Contact Skookum Engineering.

METRIC/DECIMAL EQUIVALENTS

	1/64	.015625	0.3969
1/32		.031250	0.7938
		.039370	- 1
	3/64	.046875	1.1906
1/16		.062500	1.5875
	5/64	.078125	1.9844
		.078740	- 2
3/32		.093750	2.3812
	7/64	.109375	2.7781
		.118110	- 3
1/8		.125000	3.1750
	9/64	.140625	3.5719
5/32		.156250	3.9688
		.157480	- 4
	11/64	.171875	4.3656
3/16		.187500	4.7625
		.196850	- 5
	13/64	.203125	5.1594
7/32		.218750	5.5562
	15/64	.234375	5.9531
		.236220	- 6
1/4		.250000	6.3500
	17/64	.265625	6.7469
		.275591	- 7
9/32		.281250	7.1438
	19/64	.296875	7.5406
5/16		.312500	7.9375
		.314961	- 8
	21/64	.328125	8.3344
11/32		.343750	8.7312
		.354331	- 9
	23/64	.359375	9.1281
3/8		.375000	9.5250
	25/64	.390625	9.9219
		.393701	- 10
13/32		.406250	10.3188
	27/64	.421875	10.7156
		.433071	- 11
7/16		.437500	11.1125
	29/64	.453125	11.5094
15/32		.468750	11.9062
		.472441	- 12
	31/64	.484375	12.3031
1/2		.500000	12.7000
		.511811	- 13

	33/64	.515625	13.0969
17/32		.531250	13.4938
	35/64	.546875	13.8906
		.551181	- 14
9/16		.562500	14.2875
	37/64	.578125	14.6844
		.590551	- 15
19/32		.593750	15.0812
	39/64	.609375	15.4781
5/8		.629921	15.8750
		.625000	- 16
	41/64	.640625	16.2719
21/32		.656250	16.6688
		.669291	- 17
	43/64	.671875	17.0656
11/16		.687500	17.4625
	45/64	.703125	17.8594
		.708661	- 18
23/32		.718750	18.2562
	47/64	.734375	18.6531
		.748031	- 19
3/4		.750000	19.0500
	49/64	.765625	19.4469
25/32		.781250	19.8438
		.787402	- 20
	51/64	.796875	20.2406
13/16		.826775	20.6375
		.812500	- 21
	53/64	.828125	21.0344
27/32		.843750	21.4312
	55/64	.859375	21.8281
		.866142	- 22
7/8		.875000	22.2250
	57/64	.890625	22.6219
		.905512	- 23
29/32		.906250	23.0188
	59/64	.921875	23.4156
15/16		.944882	23.8125
		.937500	- 24
	61/64	.953125	24.2094
31/32		.968750	24.6062
		.984252	- 25
	63/64	.984375	25.0031
1		1.00000	25.4000

Decimal Equivalents of Millimeters

mm	Inches	mm	Inches	mm	Inches	mm	Inches	mm	Inches	mm	Inches
25	0.98425	38	1.49606	51	2.00787	64	2.51968	77	3.03149	90	3.54330
26	1.02362	39	1.53543	52	2.04724	65	2.55905	78	3.07086	91	3.58267
27	1.06299	40	1.57480	53	2.08661	66	2.59842	79	3.11023	92	3.62204
28	1.10236	41	1.61417	54	2.12598	67	2.63779	80	3.14960	93	3.66141
29	1.14173	42	1.65354	55	2.16535	68	2.67716	81	3.18897	94	3.70078
30	1.18110	43	1.69291	56	2.20472	69	2.71653	82	3.22834	95	3.74015
31	1.22047	44	1.73228	57	2.24409	70	2.75590	83	3.26771	96	3.77952
32	1.25984	45	1.77165	58	2.28346	71	2.79527	84	3.30708	97	3.81889
33	1.29921	46	1.81102	59	2.32283	72	2.83464	85	3.34645	98	3.85826
34	1.33858	47	1.85039	60	2.36220	73	2.87401	86	3.38582	99	3.89763
35	1.37795	48	1.88976	61	2.40157	74	2.91338	87	3.42519	100	3.93700
36	1.41732	49	1.92913	62	2.44094	75	2.95275	88	3.46456		
37	1.45669	50	1.96850	63	2.48031	76	2.99212	89	3.50393		

1 Inch = 25.400 mm



Guaranteed Tough Since 1890

WARRANTY

Conditions of Sale & Limited Warranty - **Notice to customers. Please read carefully:**

These terms and conditions contain disclaimers of warranties and strict limitation of liability and remedies.

Manufacturer warrants to the original wholesaler or OEM purchaser and/or to the original retail purchaser only that the goods, equipment or merchandise described herein will be free from defects in material and workmanship for a period of twelve (12) months from date of manufacturers shipment. Should the goods, equipment or merchandise prove defective within twelve (12) month period. Skookum will, at its option, repair or replace the same when returned to its plant, charges prepaid. If Skookum is given written notice of any such claimed defect promptly and is submitted, freight prepaid, within such twelve (12) month period for examination. Repair and/or replacement at the option of Skookum shall be the sole and exclusive remedy of the buyer for breach of the above express warranty.

Except as expressly set forth herein, Skookum makes no warranty either express or implied, that the goods, equipment, or merchandise shall be merchantable or if for any particular purpose or use, nor does it make any other warranty, express, or implied statutory. Skookum shall have no liability for incident consequential, special, general or other damages arising from the use of its product including, but not limited to: failure of the goods, equipment, or merchandise to perform any general or particular function or purpose whether such damage or failure is due to mistake or deficiency in any design, formula, plan specification, advertising material, printed instructions, defective materials, defective or improper assembly or otherwise; the sole liability of Skookum being to repair or replace, at its option, defects in material or workmanship as stated in the preceding paragraph. Skookum shall not have any responsibility or liability for damage in shipment, during assembly, installation, erection, or that arising from accidents, abuse or improper operation of the goods, equipment or merchandise.

These terms and conditions shall supersede and, in case of conflict, shall have control over any other terms or provisions in any oral or written purchase order or other document pertaining to the goods, equipment or merchandise described herein, including any negotiations between parties or as suggested by any product catalog or descriptive literature. Nor does any distributor, dealer, franchisee, independent sales representative or other person, firm or corporation have authority to assume any other obligations or liability on behalf of Skookum, or to waive, modify or change these terms and conditions. We agree, in performing the work required by any purchase order, not to discriminate against any worker because of race, creed, color, sex or national origin.

In the event of stoppage or partial stoppage of our plants or shipments of the items ordered by the customer due to causes beyond our control (such as, but not limited to: strikes, differences with workmen, fires, floods, accidents, scarcity of labor, materials, power, fuel or transportation, difficulties, war-whether in this country or abroad, government regulations, orders or proclamations, laws, acts of public enemies, mobs or rioters, or acts of God) deliveries hereunder may be suspended or partially suspended, during the continuance of such interruption.

Warranty Disclaimer: The Warranty, whether expressed or implied, shall be void if parts are altered or repaired by other than Skookum, or by their approved agent. Approval shall be in writing and required before alterations or repairs are done.

By acceptance of our sales order acknowledgment copy you accept all the terms and provisions heretofore set forth and agree that the delivery of the merchandise described in said order shall be subject to no other terms and conditions whatsoever unless additional terms are made the subject of negotiation and are covered by separate written acceptance by us.

Receipt of acknowledgment by you without written objection to us within thirty days from the date of receipt of the merchandise described in said order shall constitute an acceptance by you of the terms hereof and an agreement that the delivery of the merchandise described in said order is subject to no other terms than those stated in this acceptance.

The provisions of the instrument shall be construed in accordance with, and the rights and liabilities of both the manufacturer and purchaser shall be controlled by the laws of the state of Oregon, USA, in force as of the date of shipment by the manufacturer.

TERMS - Miscellaneous

Prices and discounts are subject to change without notice. Orders accepted with the understanding that price and discounts prevailing at the time of shipment shall apply.

Drop Ship Fees - \$25.00 on orders up to \$500.00, \$50.00 on orders from \$501.00 to \$2000.00, and \$100.00 on orders from \$2001.00 and up. Will also include Will Call for end-users picking up on behalf of the Skookum dealer.

Shipment discrepancies must be documented. Notification of discrepancies in quantities of items shipped must be made within 15 days of receipt of shipment.

Material may not be returned without prior written permission. Requests to return material should include Skookum's original invoice number.

Any items not cataloged or items not shipped within the preceding 90 days are non-returnable. Items to be returned must be in new and unused condition.

Non-cataloged items or special engineered products canceled will be subject to a cancellation charge equal to the greater of the cost of labor and material incurred by the company and no less than 25% of net order value.

For standard items returned, a minimum restocking charge the greater of 25% or \$50 shall be made, with additional charges as required for repairing items not received in good condition.

Returned items must be freight prepaid, and all transportation costs previously assumed by Skookum will be charged back.

All items are FOB Hubbard, OR, unless otherwise noted.

SKOOKUM®

www.SKOOKUMTOUGH.com



Toll Free: 800.547.8211
Phone: 503.651.3175
Fax: 503.651.3409
Email: Sales_Team@ulvencompanies.com

Mailing Address:
2310 Industrial Ave
Hubbard, OR 97032