

# Crosby®



CROSBY® CROSBY CLAMP-CO® CROSBY KUPLEX® CROSBYIP® CROSBY MAGNEX®  
CROSBY STRAIGHTPOINT® CROSBY TRAWLEX® LEBUS® McKISSICK® NATIONAL®

With Product Warning & Application Information



<b>GLOSSARY</b> (Important terms and definitions) . . . . .	2
<b>QUALITY CONTINUUM</b> (What it takes to be Crosby or Equal, Product Bulletins) . . . . .	11
<b>WIRE ROPE END TERMINATIONS</b> (Clips, Sockets, Swage Fittings, Wirelock®) . . . . .	31
<b>SHACKLES</b> (Anchor, Chain, Bolt-Type, Screw Pin, Round Pin, Wide Body) . . . . .	73
<b>SLING SAVER FITTINGS</b> (Shackles, Hooks & Accessories specifically for Web & Round Slings) . . . . .	95
<b>HOOKS &amp; SWIVELS</b> (Hooks, Latches, Swivels) . . . . .	109
<b>RIGGING ACCESSORIES</b> (Thimbles, Links, Rings, Eyebolts, Turnbuckles) . . . . .	155
<b>CHAIN &amp; ACCESSORIES</b> (Chain, Grade 80 and 100 Fittings, Alloy Fittings, Loadbinders) . . . . .	217
<b>SHEAVES</b> (McKissick and Western) . . . . .	277
<b>MCKISSICK BLOCKS</b> (Construction Blocks, Crane Blocks, Overhaul Balls, Snatch Blocks, Oilfield Blocks) . . . . .	305
<b>WESTERN AND MARINE BLOCKS</b> (Wood Blocks, Steel Blocks, Snatch Blocks, Construction Blocks) . . . . .	393
<b>CROSBYIP PLATE CLAMPS / CLAMP CO CLAMPS</b> (Vertical, Horizontal, Beam, Drum and Special Lifting Clamps) . . . . .	409
<b>CROSBY TRAWLEX® AND ACCESSORIES</b> . . . . .	437
<b>SPECIAL PRODUCTS</b> (Special Engineered Product Forms) . . . . .	447
<b>RIGGING INFORMATION</b> (Basic sling angle information, Inspection and Replacement Guidelines per ASME B30.9) . . . . .	467
<b>ALPHABETICAL INDEX</b> . . . . .	477
<b>NUMERICAL INDEX</b> . . . . .	480



## CORPORATE OFFICES

2801 Dawson Rd., Tulsa, OK 74110 • P: 918.834.4611 • F: 918.832.0940  
 2600 North Central Expressway, Suite 100, Richardson, TX 75080  
[thecrosbygroup.com](http://thecrosbygroup.com)

## United States Facilities

**Crosby-Tulsa**  
 2857 Dawson Rd.  
 Tulsa, OK 74110-5042

**Crosby-Dallas**  
 2101 Exchange Dr.  
 Arlington, TX 76011-7823

**Crosby-Longview**  
 2414 Crosby Way  
 Longview, TX 75602

**Crosby-Little Rock**  
 2511 W. Main Street  
 Jacksonville, AR 72076-4213

## Canada Facility

**Crosby-Mississauga**  
 3660 Odyssey Drive, #4  
 Mississauga, Ontario,  
 Canada L5M 7N4  
 P: (877) 462-7672  
 F: (877) 260-5106



## Europe Facilities

**Crosby-Heist-op-den-Berg**  
 Industriepark Zone b N°26  
 2220 Heist-op-den-Berg  
 P: (+32) (0)15 75 71 25  
 F: (+32) (0)15 75 37 64

**Crosby-Cergy**  
 21, rue du Petit Albi  
 Parc d'Affaires Silic  
 95800 Cergy - St. Christophe  
 P: (+33) (0)1 34 201 180  
 F: (+33) (0)1 34 201 188

**Crosby-Ede**  
 Celsiusstraat 51  
 P.O. Box 518  
 6710 BM Ede  
 P: (+31) (0)318 690 999  
 F: (+31) (0)318 690 933

**Crosby-West Midlands**  
 Station Street  
 Cradley Heath  
 West Midlands B64 6AJ  
 P: (+44) (0)1226 290 516  
 F: (+44) (0)1226 240 118



# General Information

## GENERAL CAUTIONS AND WARNINGS

All products manufactured by The Crosby Group LLC, are sold with the express understanding that the purchaser is thoroughly familiar with the safe and proper use and application of the product.

Responsibility for the use and application of the products rests with the user. The Crosby Group disseminates products warnings and end user application information through various channels. In addition, Crosby provides formal product training seminars and our engineering personnel are readily available to answer your technical questions. For more information read the Crosby General Catalog, refer to Crosby's website at [www.thecrosbygroup.com](http://www.thecrosbygroup.com), or contact your Crosby distributor or Crosby direct at 918-834-4611.

Failure of the product can occur due to misapplication, abuse, or improper maintenance. Product failure could allow the load to become out of control, resulting in possible property damage, personal injury or death.

There are numerous government and industry standards that cover products made by Crosby. This catalog makes no attempt to reference all of them. We do reference the standards that are most frequently asked about.

Ratings shown in Crosby Group literature are applicable only to new or in "as-new" condition products.

Load Limit ratings indicate the greatest force or load a product can carry under usual environmental conditions. Shock loading and extraordinary conditions must be taken into account when selecting products for use in a system.

In general, the products displayed in Crosby Group literature are used as parts of a system being employed to accomplish a task. Therefore, we can only recommend within the Working Load Limits, or other stated limitations, the use of products for this purpose.

The Working Load Limit, or Design Factor, or Efficiency Rating of each Crosby product may be affected by wear, misuse, overloading, corrosion, deformation, intentional alteration, and other use conditions. Regular inspection must be conducted to determine whether use can be continued at the catalog assigned WLL, a reduced WLL, or whether the product must be withdrawn from service.

*Specific warning and application instructions are included in this catalog. The instructions can be found at the end of each product section. The symbol shown to the right can be found on the page for products that have application instructions included in this catalog. The page numbers that the specific product information can be found are shown in the box for easy reference.*

Crosby Group products generally are intended for tension or pull. Side loading must be avoided, as it exerts additional force or loading which the product is not designed to accommodate.

Welding Crosby load support parts or products can be hazardous. Knowledge of materials, heat treatment, and welding procedures are necessary for proper welding. Crosby Group should be consulted for information.

The assigned Ultimate Load Rating of Crosby Group products for the reeving of wire, manila, or synthetic rope is based upon design; the catalog ultimate strength for the rope parts, when totaled, may exceed the assigned Ultimate Load Rating.

The Working Load Limit of a sling must not exceed the lowest Working Load Limit of the components in the system.

The recommended Proof Load on all items in this catalog is 2 times the Working Load Limit unless otherwise shown.

Products that Crosby intends for swaging are identified in this catalog. For proper swaging machine training, operations and die selection, refer to specific product section in this manual. To develop other product for swaging requires knowledge of materials, heat treatment, product design, die design and performance of the final product.

Use only new genuine Crosby parts as replacements when servicing or repairing Crosby products.

Crosby products are to be considered as sparking, unless otherwise noted.

Product Label Replacement - In accordance with ANSI Z535.4, "Product Safety Labels" should be periodically inspected and cleaned. "Product Safety Labels" should be replaced when they are no longer legible. Current Crosby warning and application labels, for applicable products, are available from The Crosby Group LLC.

Two decimal and fractional dimensions shown in catalog are intended as nominal dimensions only. If three decimal dimensions are shown, contact Crosby for tolerance information.



## LOW TEMPERATURE SERVICE

- Crosby forged and cast steel products can be used in general service conditions down to temperatures of -40° F (-40° C).
- McKissick blocks can be used in general service conditions down to temperatures of -4° F (-20° C).
- For usage of the products above at temperatures 0° F (-18° C) and colder, good rigging practice requires special attention in the following areas:
  1. Lifting should be performed at a steady rate. Shock loading should be avoided.
  2. Equipment containing bearings should have increased inspection and maintenance schedule, and may require special lubrication.
  3. All lifting equipment should be given a thorough visual inspection before each lift.
  4. Remove nicks, gouges, or cracks by grinding (5% maximum material removal).
  5. Do not use fittings that have been welded or modified after leaving the factory.
  6. If determined to be necessary by the user, lifting equipment should undergo periodic inspection by dye penetrant or magnetic particle surface inspection.

For operation at temperatures below -40° F (-40° C), consider "Cold Tuff" products or contact Crosby Engineering.

## ELEVATED TEMPERATURE SERVICE

Crosby forged and cast steel products can be used in general service conditions up to temperatures of 400° F (204° C). The following should be considered when operating up to temperatures of 400° F (204° C).

1. Products that contain non-ferrous materials, and lubricants, plastics, etc. may be adversely affected by high temperatures, and typically should not exceed 200° F (93° C).
2. Galvanized, plated or painted fittings may suffer some or total degradation of the surface finish.
3. Extended exposure to elevated temperatures can cause severe surface scaling and significant permanent reduction of properties.

For other operating temperatures or products, contact Crosby Engineering.



## DEFINITIONS

**STATIC LOAD** - The load resulting from a constant applied force or load.

**WORKING LOAD LIMIT** - The maximum mass or force which the product is authorized to support in general service when the pull is applied in-line, unless noted otherwise, with respect to the centerline of the product. This term is used interchangeably with the following terms: WLL, Rated Load Value, Resultant Working Load.

**WORKING LOAD** - The maximum mass or force which the product is authorized to support in a particular service.

**PROOF LOAD** - The average force applied in the performance of a proof test; the average force to which a product may be subjected before deformation occurs.

**PROOF TEST** - A test applied to a product solely to determine injurious material or manufacturing defects.

**ULTIMATE LOAD** - The average load or force at which the product fails or no longer supports the load. Interchangeable with Ultimate Strength.

**SHOCK LOAD** - A force that results from the rapid application of a force (such as impacting or jerking) or rapid movement of a static load. A shock load significantly adds to the static load

**DESIGN FACTOR** - An industry term denoting a product's theoretical reserve capability; usually computed by dividing the catalog ultimate load by the Working Load Limit. Generally expressed as a ratio, e.g., 5:1.

**COMMERCIAL SURFACE QUALITY** - The surface condition of the products shown in this catalog. The surface condition associated with the normal methods of production of raw material and machined surfaces. More refined surface qualities are considered as special

**FATIGUE RATED** - Tested to a minimum standard of 20,000 cycles at 1.5 times the Working Load Limit. Will meet the requirements of the Euronorm standards for fatigue.

**ADJUSTED WORKING LOAD LIMIT** - The reduced maximum mass or force which the product is authorized to support for specific non-standard loading applications.

**Ton (T)** - North American unit of measure, equals 2,000 pounds. Also referred to as a short ton. Abbreviated by capital T.

**Tonne (t)** - Metric unit of measure, equals 1,000 kg. Abbreviated by lower case t.

## LIMITED WARRANTY AND LIMITATIONS OF LIABILITY

Purchaser and Crosby expressly agree that Crosby's warranty with respect to sale of its products is LIMITED solely to Crosby's choice of repair, replacement or refund of the purchase price of any product or part thereof determined by Crosby to be defective within the first 12 months following the transfer of title of the product from Crosby to the purchaser. Installation or operation of the product in any manner other than as recommended by Crosby, shall void the warranty. No warranty is made for components and accessories made by others when such items are warranted by their respective manufacturer. **Purchaser and Crosby expressly agree that upon termination of the aforementioned 12-month period, the purchased product carries no warranty whatsoever.** Purchaser and Crosby expressly agree that the remedies provided in this section are the purchaser's exclusive remedies in connection with the purchase or use of the product.

***Neither Purchaser, user nor any third party shall be entitled to recover from Crosby (1) any consequential, incidental, punitive, special or indirect damages of any nature, including but not limited to, the cost of any labor expended by others in connection with the goods sold by reason of any alleged non-conformity or breach of warranty on the part of Crosby or costs of material on account thereof, (2) damages of any kind for loss of profits, revenue, data or data use, or (3) damages of any kind for business interruption whether determinable or speculative, loss of business information, goodwill, reputation or privacy, (4), for costs of procuring substitute goods, software or services, incurred by Purchaser, user or any third party, however, arising, whether in an action in contract, tort, under statute or otherwise, and whether or not the possibility or likelihood of such damages were reasonably foreseeable.***

**ALL OTHER WARRANTIES, INCLUDING EXPRESS WARRANTIES AND THE IMPLIED WARRANTIES OF MERCHANTABILITY AND FITNESS FOR A PARTICULAR PURPOSE ARE HEREBY DISCLAIMED. ADDITIONALLY, CROSBY HEREBY DISCLAIMS ANY OF ITS OBLIGATIONS OR LIABILITIES ARISING FROM STATUTE, WARRANTY, CONTRACT, TORT OR NEGLIGENCE.**

**Complete Agreement:** This Warranty between purchaser and Crosby is complete. All prior or contemporaneous discussions, representations and/or understandings are merged into this Warranty. All prior or contemporaneous agreements between the parties are superseded by this Warranty.

**Choice of Law and Venue:** Purchaser and Crosby expressly agree that any dispute arising out of these Terms and all disputes concerning or relating to the purchase, use or operation of the goods shall be governed by the laws of the State of Oklahoma, excluding any conflicts of law rules and any lawsuit shall be filed in Tulsa, Oklahoma.











# Explanation of Symbols

C - Carbon, A - Alloy, B - Bronze, L - Hook supplied with latch kit, SS - Stainless Steel, S or SC - Self Colored, Painted or Oiled, G - Coated for corrosion protection; may include Hot Dip galvanizing, electrolytic depositing, dimetcoated, impact galvanizing, spraying, etc.

All ratings given in tons refer to short tons of 2,000 lb Ratings given in metric tons equal 2,204 lb, and are mentioned as "tonnes" (t) or "metric tons".

Hot Dip galvanized Crosby products meet or exceed ASTM A 153 requirements.









SYMBOL	EXPLANATION OF SYMBOLS
	<p><b>QUIC-CHECK®</b> is a patented concept developed by Crosby's Research and Development Department which represents Crosby's ongoing commitment to Quality. <b>QUIC-CHECK®</b> incorporates the strategic placement of marking indicators on traditional rigging products to indicate reference points designed to enhance the safe and proper use of Crosby products.</p>
	<p><b>Load Rated®</b> is a registered Crosby trademark that identifies products that have the Working Load Limit indicated or affixed to it</p>
	<p><b>Fatigue Rated®</b> is a registered Crosby trademark that identifies products that have proven to provide improved fatigue life (fatigue resistance) in actual use.</p>
	<p><b>Quenched and Tempered®</b> is a registered Crosby trademark identifying product that is heat treated utilizing Crosby's perfected quench and tempering methods.</p>
	<p><b>MAXTOUGH®</b> is a registered Crosby trademark identifying products that are statistically verified to meet or exceed impact values of 31 ft•lbf at -4° F (42 Joules at -20° C) based on a high level of confidence. The confidence level is an index of certainty. MAXTOUGH is another Value-Added benefit of The Crosby Group.</p>
	<p><b>Type Approved</b> is a symbol that identifies products that have been Type Approved by various third party organization Meeting a standard can be declared as a result of "TYPE APPROVAL" by a third party organization. Type Approval requires:</p> <ol style="list-style-type: none"> <li>(1) A <b>TYPE APPROVAL CERTIFICATE</b> that verifies that the product design complies with the referenced standard(s) and,</li> <li>(2) A <b>(MSA) MANUFACTURING SURVEY</b> that verifies that the manufacturing location has been verified as capable of making the product.</li> <li>(3) A <b>PRODUCT CERTIFICATE</b> must be made available that verifies that the product shipped meets the requirements of the <b>TYPE APPROVAL</b> and <b>MSA</b>. This product certificate must reference a serial number or .I.C. and is issued for each product produced.</li> </ol>
	<p>Products containing this logo are <b>RFID Equipped</b> and are designed to be used with the Crosby <b>QUIC-CHECK®</b> Inspection and Identification System (U.S. Patent 7,825,770)</p>
	<p><b>Crosby Certpro®</b> is a web-based system that Crosby or an Authorized Distributor can create a certified product certificate for genuine Crosby products. Product performance is key to lifting applications and proper certification of critical lifting products is often required. Certpro supports the following basic certifications</p> <ol style="list-style-type: none"> <li>(1) Standard C of C: Self declaration that the product is in conformance with the specifications and provisions set forth in Crosby literature current at the time of manufacture.</li> <li>(2) Material Certificates: Available for non-block products as a complement to standard C of C as well as other certifications, PIC is required.</li> <li>(3) Data Books: Available for selected products to support third party certification and other special testing requirements.</li> </ol>
	<p><b>Crosby Verification Pro®</b> is a web based system available on the Crosby website that allows customers to confirm that the certificate you hold in your hand matches the product information in the Crosby database. Verification Pro provides a second layer of confidence that the product supplied with the certificate is indeed a genuine Crosby product</p>

The Crosby Group reserves the right to change product design, materials, and specifications without incurring obligations. Reference to standards or specifications in Crosby literature is only intended to show a general compliance and must not be interpreted as meeting all terms of a contract or purchase order.





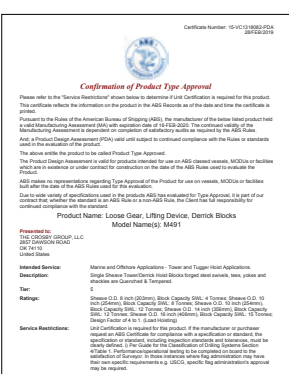





Several Crosby products have been Type approved by various third party organizations. Meeting a standard can be declared as a result of "TYPE APPROVAL" by a third party organization. Type approval requires:

1. A **TYPE APPROVAL CERTIFICATE** that verifies that the product design complies with the referenced standard(s), an
2. A **(MSA) MANUFACTURING SURVEY** that verifies that the manufacturing location has been verified as capable of making the product, a
3. A **PRODUCT CERTIFICATE** must be made available that verifies that the product shipped meets the requirements of the TYPE APPROVAL and MSA. This product certificate must reference a serial number or .I.C. and is issued for each product produced.



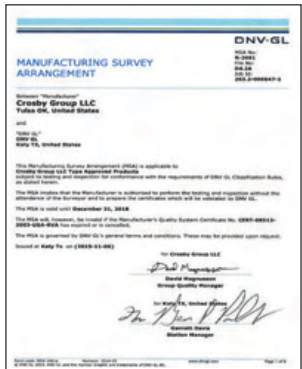





ABS / DNV LOCATOR	MANUFACTURING SURVEY (MSA)	TYPE APPROVAL CERTIFICATE	PRODUCT CERTIFICATE
<p align="center"><b>ABS HOOKS</b></p> <p><b>TA# 16-HS1542711-PDA</b></p> <p>Certificate Included with Standard 319, 320 and 322, 3322 hooks on pages 112 - 116.</p>			
<p align="center"><b>ABS SHACKLES</b></p> <p><b>TA# 16-HD1542710-PDA</b></p> <p>Certificate Included with Standard 209, 210, 2130, 2140 and 2150 Shackles on pages 77 - 83.</p>			
<p align="center"><b>ABS M-491 BLOCKS</b></p> <p><b>TA# 15VC1318082</b></p> <p>Certificate is available with all Standard M-491 blocks shown on page 371.</p>			

# Type Approved Products

ABS / DNV LOCATOR	MANUFACTURING SURVEY (MSA)	TYPE APPROVAL CERTIFICATE	PRODUCT CERTIFICATE
<p align="center"><b>DNV CT SHACKLES TA# S-8378</b></p> <p>Certificate is available with 2130CT and 2140CT shackles shown on page 87.</p>			
<p align="center"><b>DNV CT MASTER LINKS TA# S-8355</b></p> <p>Certificate is available with A-342CT and A-345CT links shown on page 160-161.</p>			
<p align="center"><b>DNV CT SIDE PULL HOIST RINGS TAD00000HJ</b></p> <p>DNV Side Pull Hoist Rings are special order hoist rings that must have the certificate requested upon order.</p>			

The Crosby Group reserves the right to change product design, materials, and specifications without incurring obligations. Reference to standards or specifications in Crosby literature is only intended to show a general compliance and must not be interpreted as meeting all terms of a contract or purchase order.



ABS / DNV LOCATOR	MANUFACTURING SURVEY (MSA)	TYPE APPROVAL CERTIFICATE	PRODUCT CERTIFICATE
<p><b>DNV OC MASTER LINKS TAS00001V</b></p> <p>Certificate is available with all standard A-344 and A-347 links shown on pages 162 - 163.</p>			
<p><b>DNV OC SHACKLES TA# S-8357</b></p> <p>Certificate is available for standard 2t through 25t. 2130 shackles shown on pages 79.</p>			
<p><b>DNV 2160 SHACKLES TAS00000K9</b></p> <p>Certificate and full test data book provided with standard 2160 shackles 18t through 1550t on pages 84 - 85.</p>			

The Crosby Group reserves the right to change product design, materials, and specifications without incurring obligations. Reference to standards or specifications in Crosby literature is only intended to show a general compliance and must not be interpreted as meeting all terms of a contract or purchase order.



In a world where things are not always what they seem... **how can you ensure genuine Crosby products are being used on the job site?**

A simple three-step process helps to ensure you are always supplied genuine Crosby product:

**STEP 1** Purchase your Crosby product only through authorized Crosby distributors. Crosby's large network of authorized distributors are poised to provide you the many value added services available from Crosby.

**STEP 2** When purchasing Crosby products, always require an authentic Certificate of Conformance (including the item's (PIC) Product Identification Code) generated from Crosby's on-line certificate retrieval system; available 24/7 only from your local authorized Crosby dealer.

CertPro® certificates provide you the assurance that you are receiving authentic Crosby products. A variety of certificate types are available through CertPro®. Examples include: Certificates of Conformance, Material Certificates and Type Approval Certificates



**STEP 3** If there are any questions about the authenticity of your Crosby CertPro® certificates, they can be verified through CrosbyVerificationPro®, our new on-line certificate system. Through Crosby VerificationPro®, YOU can verify the certificate's authenticity by simply entering information from the supplied certificate (the certificate number, the stock number, the Product Identification Code (PIC) and the name of the authorized Crosby dealer) onto the user friendly screen, located at our website.



[thecrosbygroup.com](http://thecrosbygroup.com)

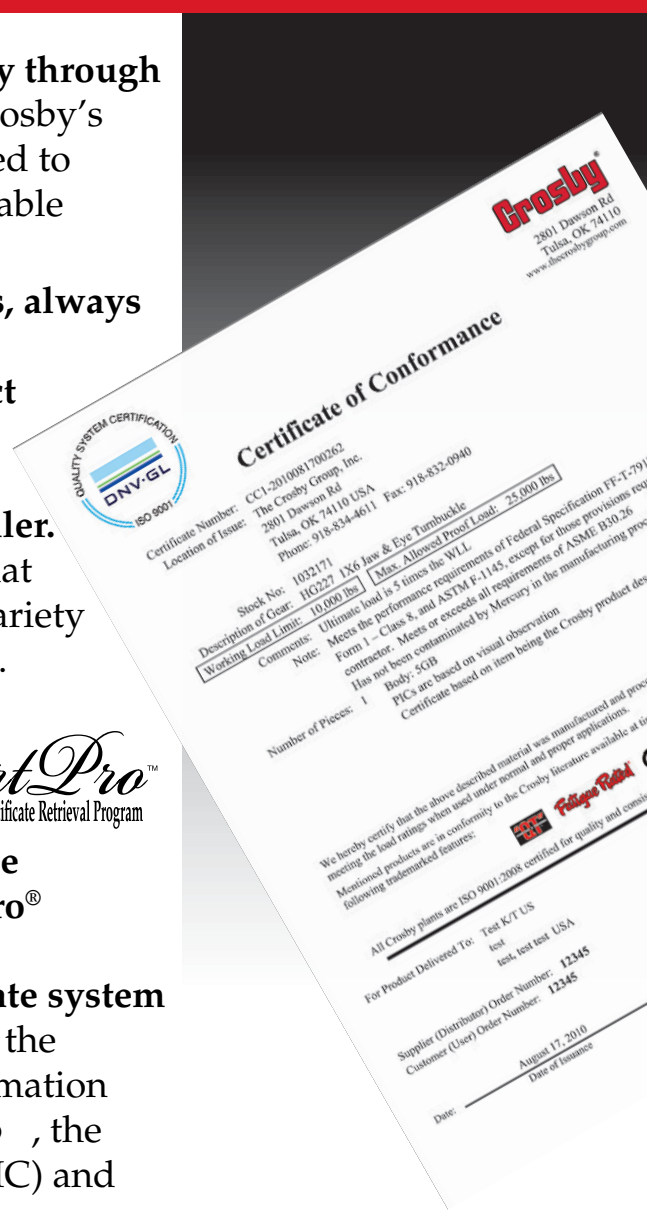



# Wireless Tension and Compression Load Monitoring Equipment

## Know the load

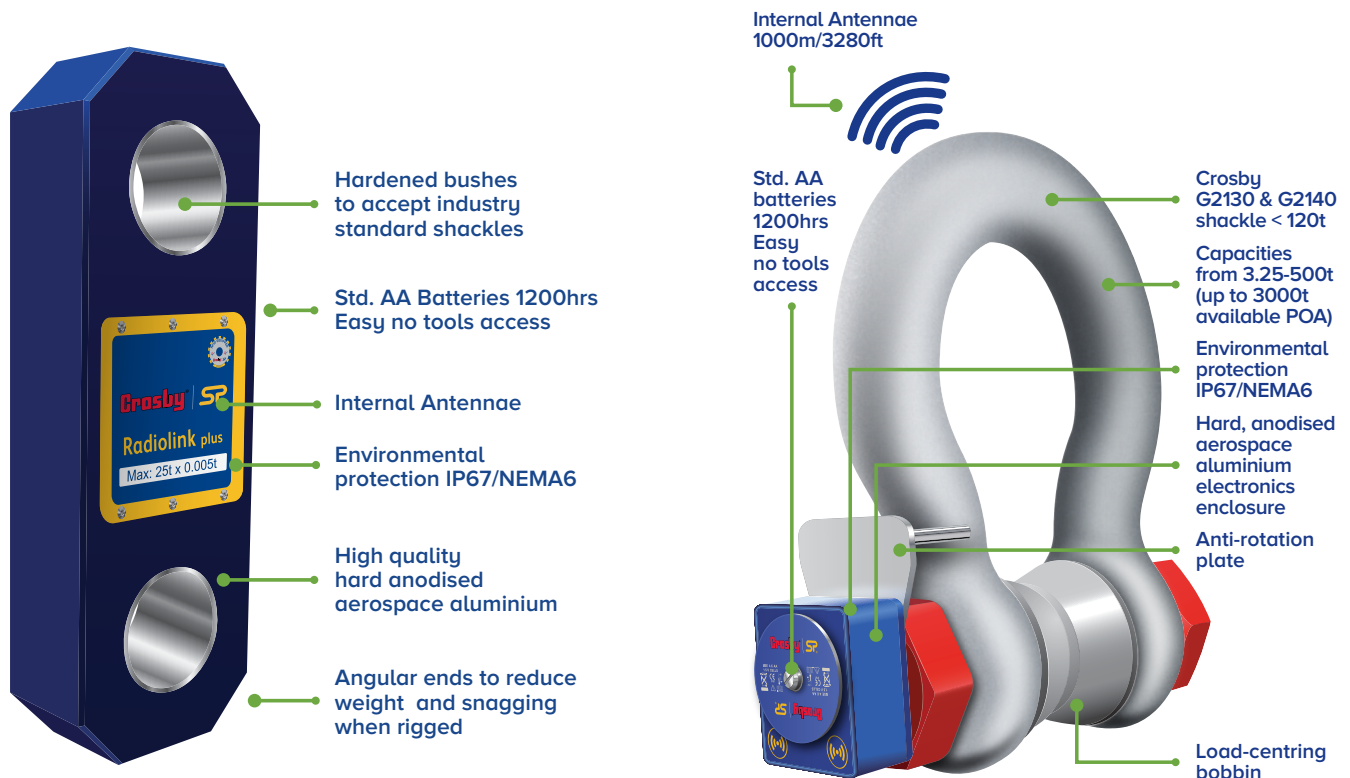

## Radiolink Plus

The Straightpoint Radiolink plus (RLP) is a DNV-GL type approved wireless tension load cell capable of weighing and dynamic load monitoring from 1t to 500t .

- Standard ATEX and IECEx version for zones 0,1&2

### Two versions of the RLP are available:

- Wireless long range 2.4GHz version to 1000m (3,280 ft)
- Bluetooth compatible on iOS or Android to 100m (328 ft)

## Wireless Loadshackle

The Straightpoint Wireless Loadshackle (WLS) for use with limited headroom or super heavy lift projects.

- WLL from 3.25t to 400t (up to 3000t)

### Two versions of the WLS are available:

- Wireless long range 2.4GHz version to 1000m (3,280 ft)
- Bluetooth compatible on iOS or Android to 100m (328 ft)

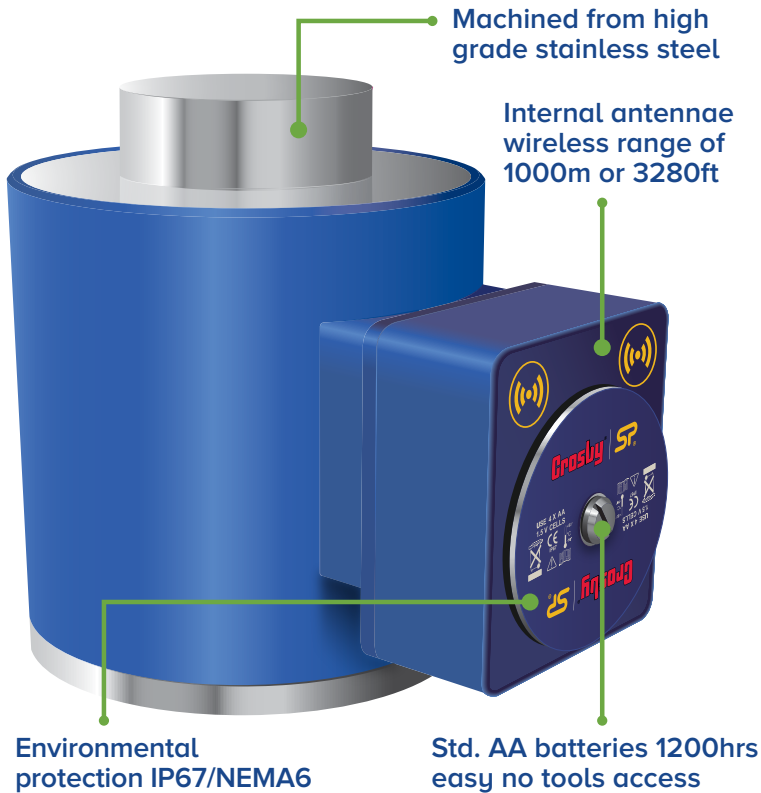

## Wireless Compression Load Cell

The Straightpoint Wireless Compression Load Cell (WNI). Eliminates hard to maintain cables saving time and money on large scale projects.

- Multiple compression loadcells can connect wirelessly to PC, USB dongle, or SW-HHP wireless handheld display
- Reduced maintenance costs by eliminating cables and connectors
- Increased flexibility for use on numerous heavy lift applications

### Two versions of the WLS are available:

- Wireless long range 2.4GHz version to 1000m (3,280 ft)
- Bluetooth compatible on iOS or Android to 100m (328 ft)



## Wireless Handheld Plus (SW-HHP)

The Handheld plus is a rugged and versatile digital handheld display with an extensive range of features. Providing a single point source to monitor load measurements in real-time.



Safety, reliability and quality are paramount in the lifting and rigging industries Straightpoint designs and manufactures to the highest standards including ISO9001, ATEX and DNV Type approvals.





**HR1000MCT "Cold TUFF" Hoist Ring**  
Page 179

Choose the new metric HR1000MCT for versatile and dependable material handling in extreme conditions such as subsea and other saltwater environments. Like our standard heavy lift hoist rings, the forged bail provides greater durability in potentially abusive environments.



**Crosby IPU10A Automatic Vertical Clamp**  
Page 413

Features of the new IPU10A "automatic closing" models allow the user to properly attach the clamp to the top edge of steel in hard to reach applications, eliminating the need for ladders or other potentially unsafe devices.



**Crosby SL150 Slide-Loc Lifting Point**  
Page 187

The new Crosby SL-150 Slide-Loc lifting point is an innovative alternative to eye bolts. At the center of the new design is a patent pending locking mechanism, making the lifting point well suited for quick attachment to the load surface, and a bail that swivels 360 degrees to assist with proper alignment of sling...all without the need for tools.



**G-2100 Release & Retrieve ROV Shackle with QUIC-Thread Bolt** • Page 90

The New Crosby Release and Retrieve shackles G-2100 and G-2110 were developed in conjunction with the world's top subsea specialists. Crosby ROV shackles feature an innovative patent pending captured bolt design, and API compliant features that are an industry first. Best of all, the shackles come factory ready and require no end user modification.



**S-13326AH SHUR-LOC® Handle Swivel Hook with Bearing** • Page 120 & 234

The SHUR-LOC® Handle Swivel Hook with Bearing features a handle opening big enough to accommodate almost any size gloved hand for complete control over the hook and load.

The lubricated bearing allows the user to better position loads when lifting. Made with forged alloy steel, the hook is suitable for use with Grade 100 or Grade 80 chain.



**S-1316AH SHUR-LOC® Handle Eye Hook** • Page 120 & 234

The SHUR-LOC® Handle Eye Hook gives you better control of your load without compromising the operator's safety. The new ergonomic handles are roomy enough for use with almost any size gloved hand for complete control over the hook and load. Made with forged alloy steel, the hook is suitable for use with Grade 100 or Grade 80 chain.

**IPPE10B(E) & IPPE10BNM**  
Page 418

The IPPE10B(E) & IPPE10BNM are perfect for lifting and transferring bundles of non-sagging steel plates in horizontal position. The jaw opening can be easily adjusted. Raising the handle opens the clamp. This facilitates the easy and quick placing or removing of the clamp.



**IPBK10 Beam Clamp**  
Page 419

The IPBK10 Beam Clamp is used for lifting, transferring and stacking H-Beams. A ring-center hoist eye allows for the beam flange to remain vertical. This series of clamps can be used in vertical and horizontal moving, transferring and stacking of different types of structural designs, such as H-Beams, angles, etc, depending on the application desired.



### THE QUALITY CONTINUUM

A symbol identifying six segments of Crosby's business that when viewed as one, differentiates Crosby in the market place.

The six qualities are:

*Customer Service*  
*Research & Development*  
*Engineering*  
*Manufacturing*  
*Complete Product Line*  
*Risk Management*

### CROSBY COMMUNICATION SYSTEM

#### PURPOSE

The Crosby Communication System has been developed to convey the positive aspects, or Value Added features of the Quality Continuum to the marketplace.

#### RESOURCES

The resources of the Crosby Communication System which are utilized to implement the program include:

*Trained Crosby Personnel*  
*Video Training Program*  
*Modular Training Presentations*  
*Crosby Literature*  
*Product Bulletins*  
*Warnings and Application Information*

The individual Product Bulletins, which address and identify many of the key elements that differentiate Crosby in the marketplace, are included in this section for your information.





### Personnel Platform

This brochure translates the rigging requirements established by OSHA concerning lifting personnel into various types of components that could be used to comply with the intent of the regulation.

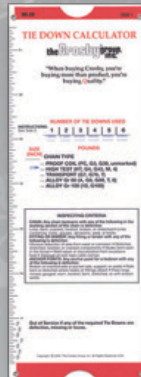

### Tie Down Calculator

This chart contains detail on various tie down related areas such as determining how many tie downs are required depending on what type of systems are used, determining the minimum number of tie downs that you must have to remain in service, and detailed inspection criteria. The information in the chart is adapted from the CVSA Cargo Securement Tie Down Guidelines, November 2003.

**Contact Your Local Authorized Crosby Distributor or Our Customer Service Department for more information.**

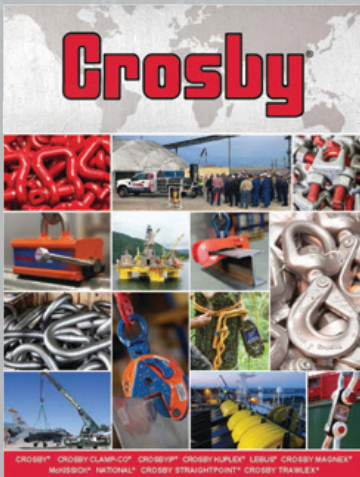

### General Catalog

Our most comprehensive piece of literature. The Crosby general catalog contains detailed engineering specifications, definitions, illustrations, and drawings, as well as application instruction and warning information on selected items to assist in selecting the proper equipment for the job.

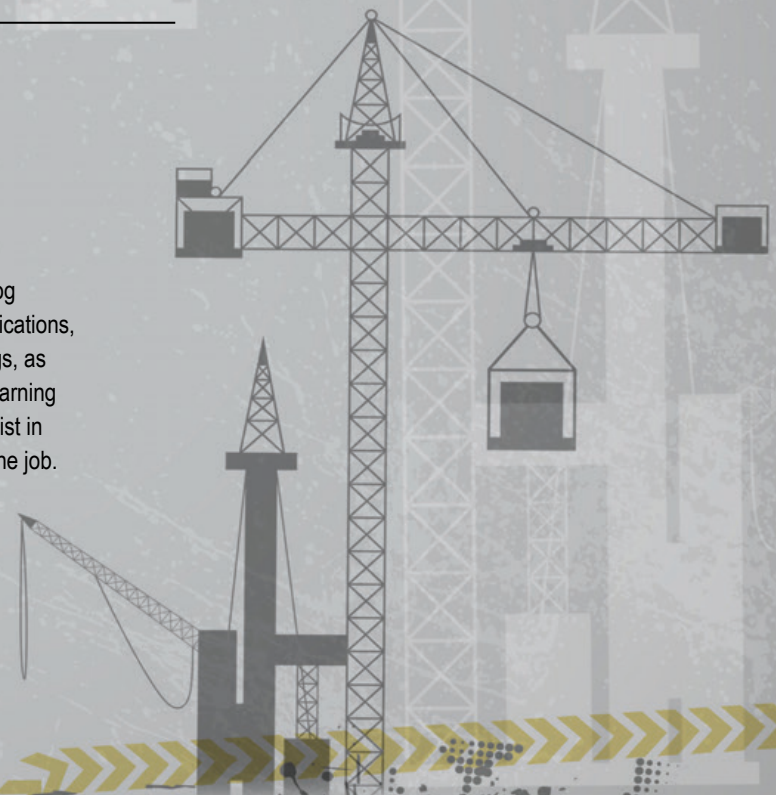





## Crosby Website Features...

### ON-LINE CATALOG

Check out the latest in Multi Language catalogs:

- English
- Portuguese
- Spanish
- Russian
- German
- Chinese
- Italian
- Korean
- French

### PRODUCT INFORMATION

Our online catalog also features information on...

- New Products
- Product
  - Drawings
  - Authenticity
  - Warnings
- MSDS Sheets

### TRAINING INFORMATION

We offer Training for our products.

- Seminar Schedule
- Request on-site Training
- Order training material
- Rigging aptitude test

### SALES REP LOCATOR

Find knowledgeable sales representatives near you.

### BUSINESS PARTNER CENTRAL

Log on to our specialized distributor services.



## Crosby Training Seminars

Distributor sponsored seminars are scheduled throughout the world, or can be held on-site at your location.



### CROSBY LITERATURE

Your best training material and selling tools. These product specific brochures contain important information on rigging requirements, product application and warning instructions plus engineering specifications, definitions, illustrations photos and drawings.



### CROSBY REFERENCE MATERIAL

**Tie Down Calculator** - contains details on various tie downs required for your type of system. Detailed inspection criteria adapted from the CVSA Cargo Securement Tie Down Guidelines.

**National Die Guide** - assists you in selecting the proper die to meet your swaging needs. The chart shows the correct stock number to use when ordering dies.

**Lifting Guide** - pocket size, laminated folding card with information on rigging, inspection, capacities and design factor. Each card is packed with information on sling angle, load distribution and hardware.



### CROSBY TRAINING WORKBOOKS

Crosby Seminar Workbooks provide an excellent source for product and application information, with many references to applicable standards. These workbooks are the same books used in our training seminars.



Scan this QR code with your smart device to view the full list of our training materials.

*The Market Leader: Yesterday Today and Tomorrow*

When you read on a contract the statement **“Crosby or Equal,”** you owe it to yourself and the personnel that will be using the product to understand that there is no equal to Crosby. The following information has been designed to help you determine the many “Value Added” features of Crosby products that are the foundation for the performance characteristics and technical support required from a quality manufacturer. You will see from the following information that **“When buying Crosby, you’re buying more than product, you’re buying Quality.”**

### Engineering Excellence

The majority of Crosby’s products are “Heat Treated”. The “Heat Treatment” allows the product to deform if overloading occurs, giving warning before ultimate failure. An “As-Forged,” or non-heat treated product, will break with little or no warning. This is called a “Catastrophic Failure”, and is a result of brittleness or lack of toughness in the non-heat treated product as compared to the “Heat Treated” product.

### Quality Control

The majority of the steel purchased by Crosby is isolated from production until approved by our metallurgical lab. Each product is individually “PIC Coded” (Product Identification Code) to allow traceability to its respective date of production and material certification

### Durability

Competitors' products cannot be substituted in place of Crosby's just because they look alike. Crosby products are manufactured with the highest design factors in the industry. Crosby's products are better able to withstand abusive field conditions because of the improved impact and fatigue characteristics designed into each item of our line. Crosby recognizes the importance of all four of these essential properties in its products: *Working Load Limit, Ductility, Fatigue and Toughness.*

### Recognized Dependability

Crosby is considered the standard of the industry, both nationally and internationally. This can be drawn from the fact that most contracts involving rigging products, in the U.S. and around the world, read “Crosby Only” or “Crosby or Equal”.

### Industry Education

Crosby has always been concerned that our users are knowledgeable with the installation, use, inspection, and maintenance of our products. Crosby offers a formal product instruction and warning program which includes such “Value Added” features as instruction sheets attached to individual items, comprehensive literature, and a video training program. A Technical Support Team is also ready to answer any questions in regard to our products or services. This instruction can be provided through training seminars and on-site engineering applications. These services provide important benefits, such as accident prevention which results in lower costs of doing business for our customers.

### Customer Service

The phrase Customer Service at Crosby means more than just having the product available when you need it. Customer Service also means having a full time, knowledgeable District Sales Representative available to serve you. It also means having a well trained and fully equipped Customer Service Department, a broad product line offering, 3200 Authorized Crosby distributors worldwide, and a Technical Support Team second to none. Finally, Customer Service means having a management team dedicated to ensure the previously mentioned services run smoothly so that your needs are met.

IF YOU NEED MORE INFORMATION ABOUT THESE VALUE ADDED BENEFITS, PLEASE CONSULT YOUR SAFETY AND RIGGING DEPARTMENT, YOUR LOCAL CROSBY DISTRIBUTOR, OR A CROSBY REPRESENTATIVE BEFORE MAKING YOUR DECISION!

# Crosby®

***Remember: “When buying Crosby, you’re buying more than product, you’re buying Quality.”***



# Quality Continuum

Crosby's Quality Continuum is a Symbol Identifying Six Segments of Our Business that, when Viewed as One, Differentiates Us in the Marketplace.

THE QUALITY CONTINUUM	THE VALUE ADDED FEATURES
<p><b>1 MANUFACTURING</b>                      Manufacturing is the process of turning a raw material into a finished product. When it comes to manufacturing, The Crosby Group has extensive and unique capabilities that equip it with the tools needed to provide the quality and type of fittings and blocks needed by our customers. Modern facilities and up-to-date processes support the manufacturing of our products within Crosby, by Crosby employees. Our Product Identification Code traces the manufacturing process from raw material to production, helping to insure that the proper controls are maintained.</p>	<ul style="list-style-type: none"> <li>• Modern facilities and state-of-the-art processes that support the manufacture of our products.</li> <li>• Extensive and unique capabilities that equip us with the tools needed to provide the quality and type of fittings and blocks needed by you, the customer.</li> <li>• Traceability of each product through the manufacturing process (from raw material to production) with our Product Identification Code (PIC , System which helps to insure that the proper controls are maintained.</li> </ul>
<p><b>2 RISK MANAGEMENT</b>                      Risk management is the practice of controlling or managing the factors of uncertain hazards. To Crosby, risk management requires that the risks of doing business must be reduced by concrete steps that have an impact throughout the business, from the manufacturer to user. Training and formal Product Warnings are major tools that Crosby has made available to support this effort.</p>	<ul style="list-style-type: none"> <li>• Comprehensive product literature.</li> <li>• Formal product instruction and warning program available to all users of Crosby products.</li> <li>• Many products are individually bagged or tagged with product warning and proper application information.</li> <li>• Training videos are available on several subjects.</li> <li>• Crosby Product Training Seminars are available to users.</li> </ul>
<p><b>3 RESEARCH AND DEVELOPMENT</b>                      Research and Development is the ongoing effort to realize the potential of improved products resulting from scholarly and scientific investigation. At Crosby, our research and development is focused by our staff who draw upon the state-of-the-art facilities available in our centralized laboratory in Tulsa, OK.</p>	<ul style="list-style-type: none"> <li>• Development of manufacturing processes for improved product performance.</li> <li>• Enhanced material toughness and properties through the selection of raw material and proper metallurgical processing.</li> <li>• Support of the effort to provide more efficient product design utilizing less raw material and common design.</li> </ul>
<p><b>4 COMPLETE PRODUCT LINE</b>                      Crosby is a worldwide company that is the premier source of blocks and fittings for the lifting and material handling industries. As a single source, Crosby offers a full line of products that is the broadest selection available to the lifting and materials handling industries.</p>	<ul style="list-style-type: none"> <li>• Scaffold pulleys to the largest lifting tackle in the world.</li> <li>• Forged Wire Rope Clips from 1/8" to 3".</li> <li>• Shackles from 1/3 tonne to 1200 tonne.</li> <li>• A variety of hooks from 1/3 tonne to 300 tonne.</li> <li>• A complete assortment of links, rings, forged swivels and thrust bearing swivels.</li> <li>• Product available in both carbon steel and alloy steel.</li> <li>• Roll Forged sheaves to "Cold Tuff" sleeves and other swaging products</li> <li>• Custom designed products to meet your specific needs</li> </ul>
<p><b>5 CUSTOMER SERVICE</b>                      "Customer Service is what the customer says it is." Crosby takes this definition serious! . We recognize that customer service begins with availability of product, order placement and tracking, and accurate information. But at Crosby we KNOW that Customer Service is more than just having the product available when you need it. It is the company-wide effort required to drive the organization to discover and meet our customers' expectations.</p>	<ul style="list-style-type: none"> <li>• Full time, knowledgeable District Sales Representatives.</li> <li>• A well trained and fully equipped Customer Service Department which can address standard products.</li> <li>• An Engineered Products Group that coordinates customers' special needs from design through manufacturing and application.</li> <li>• A Technical Support Team ready to explain our products and service.</li> <li>• A Management Team dedicated to the principle that "Customer Service is what the customer says it is."</li> </ul>
<p><b>6 ENGINEERING</b>                      Engineering is the application of scientific principles to practical ends in the design, construction and use of equipment and systems. Crosby engineers its products to perform. The application of finite element analysis is but one example of the engineering expertise available at Crosby that has resulted in Crosby being considered the standard of the industry, nationally and internationally.</p>	<ul style="list-style-type: none"> <li>• Proper selected material and heat treatment process that allows for superior strength and impact and fatigue performance.</li> <li>• Active participants in professional societies and committees including ASTM, CVSA, API, ASME/ANSI.</li> <li>• Extensive expertise in computer aided design (CAD), Finite Element Analysis, Non-destructive Testing and Failure Analysis of Products.</li> <li>• ISO 9001 Certified</li> </ul>

**Remember: "When buying Crosby, you're buying more than product, you're buying Quality."**



## Questions & Answers

### What is the Crosby Quality Continuum?

The Crosby Quality Continuum is a symbol that identifies six segments of Crosby's business that, when viewed as one, differentiates Crosby from the competition in the marketplace. The six (6) segments are Customer Service, Engineering, Manufacturing, Risk Management, Research and Development and a Complete Product Line.

### What is the Communication System?

The Crosby Communication System is a systematic effort to convey the positive aspects, or Value Added features of the Quality Continuum, to the marketplace.

### What is the Audience for the Crosby Communication System?

The Crosby Communication System recognizes its audience as including: Crosby employees, Authorized Crosby Distributors, End Users of Crosby, and Institutional buyers or standards setting organizations.

### What are Some of the Resources Available?

The Crosby Communication System can successfully draw upon the many skilled and knowledgeable people within Crosby, our Video Training Programs, the product bulletins, Crosby product literature, and the product presentations that have been prepared.

### What Type of Training is Available?

Crosby offers comprehensive product and application seminars around the world that address most Crosby product lines. Customized training sessions are also possible. In addition to product application, the sessions can also address inspection requirements, proper use, applicable standards, and importance of metallurgical properties. The training sessions may also include workshops to improve the learning experience.

### How Can This Help the User of Crosby Products?

Crosby's users can benefit from the Crosby Communication System by recognizing the impact that Crosby's Value Added features can have on employee skills, employee safety, worker compensation costs, productivity, insurance premiums, and the ability to meet OSHA and other standards.

### How Did These Concepts Develop Through The Years?

Crosby has always been concerned that our users be knowledgeable about the installation, use, inspection, and maintenance of our products. It was in 1987 that Crosby developed the theme "It's Crosby, It's Quality" to highlight the Quality built into the full line of products. This evolved into the Quality Continuum concept in 1988 and 1989, when we recognized that: "When buying Crosby, you're buying more than product, you're buying Quality." Then in 1990, the Crosby Communication System was formalized.



# "There is No Equal"

The Market Leader: Yesterday Today and Tomorrow

## World Standards

### CROSBY ISO 9001

The International Standardization Organization (ISO) brought standardization to the international level in 1987 by defining three levels of quality assurance. These are ISO 9001, ISO 9002, and ISO 9003. ISO 9001 is the most comprehensive level. This level involves design, development, production, and shipping. A total of 20 quality system elements apply to ISO 9001. ISO 9001 requires that all procedures, work instructions, processes and related activities be documented.

Certification to ISO 9001 requires a "third party" audit of all facilities prior to attainment and ongoing auditing every six months.

Certification to ISO 9001 is a solid foundation on which to build and clear evidence that the organization "does what it says." Attainment of ISO 9001 forms the basis for meeting other world standards and provides customers with documented proof of the organization's ability to consistently provide product quality and performance.

Adherence to ISO 9001 is rapidly becoming a major element of purchasing contracts throughout the world.

### THE COMPETITION

**Ask:** Do they meet ISO 9001 standards?

**Ask:** Are they an ISO 9001 certified company

**Ask:** If not, do they plan to, and do they have an implementation schedule?

**Ask:** If not, how will they support the future needs of international companies and the Department of Defense?

**Ask:** What other "world standards" of performance do they meet?



Crosby is proud to have all of our facilities, Worldwide, awarded certification for our Quality Assurance Program according to ISO 9001 by DET NORSKE VERITAS (DNV). The criteria outlined by ISO 9001 have been adopted by the company and its employees over the years at Crosby through our ongoing quality programs. Quality has been built into our products and corporate philosophy from the beginning.

"This internationally accredited certification is a true measurement of Crosby's Quality leadership, and its commitment and leadership in Quality."

Crosby made the commitment and investment needed to attain ISO 9001 certification for one reason, to support the future needs of our distributors and end users worldwide.



### AMERICAN PETROLEUM INSTITUTE (API)

The American Petroleum Institute provides third party certification for products used in the oilfield and other petroleum related activities. They provide quality assurance certification under the API-Q1 program. Manufacturers who meet their criteria qualify to manufacture under the API-Q1 program and to utilize the API monogram. API also provides design and manufacturing criteria, for API-8C. All oilfield blocks should meet API-8C criteria.

### THE COMPETITION

**Ask:** Are they certified to API-Q1?

**Ask:** Do they have capability to meet API-8C when required?



McKissick is certified under API-Q1 to manufacture blocks and sheaves for use in the oilfield. All oilfield blocks are designed and manufactured to API-8C requirements.



### OTHER WORLD STANDARDS

- American Bureau of Shipping (A.B.S.)
- Lloyds Register of Shipping (Lloyd's)
- DET NORSKE VERITAS (DNV)
- Association of Belgian Industry for Safety and Health (AIB-VINÇOTTE), (AV), (VGS)
- Control Organization of German Industry for Safety and Health (DIN)
- Netherland Labor Inspection (AI)
- Nuclear Regulatory Commission (NRC)
- Defense Contract Administration Services Management Area (DCAS)
- Registro Italiano Navale (RINA)

### THE COMPETITION

**Ask:** What world standards are they familiar with?

**Ask:** Can they demonstrate the ability to meet these standards when needed?

**Ask:** Do they have quality systems and product performance needed to document adherence to these standards?



Crosby has demonstrated capability in various countries and with many products. Crosby actively participates in standards-setting committees in both the United States and Europe. Crosby has frequently certified shackles, sheaves, blocks, and hooks to various world standards when required.

**Remember: "When buying Crosby, you're buying more than product, you're buying Quality."**

## Third Party Certificatio

Third Party certification by product provides one or more of the following services

- **Inspection • Certification Service • Testing Service •**

This Certification can be confirmed to their standards, the customer's standards, or the manufacturer's own standards. Crosby, if requested at time of order, will work with you to certify any of our products to any third party organization.

### ISO 9001 CERTIFICATION PROVIDES YOU:

- **THIRD PARTY CERTIFICATION** that the Crosby Group meets the rigorous requirements of ISO 9001.
- **THIRD PARTY PROOF** that Crosby's Quality Assurance System is ongoing through a comprehensive audit program.
- **THIRD PARTY PROOF** that Crosby meets the high standards of design, manufacture and service now demanded by world markets.
- **MANUFACTURING ACCOUNTABILITY. ISO 9001** certification assures you that at Crosby, "WE DO WHAT WE SAY WE DO" at all of our manufacturing facilities. This, coupled with Crosby's comprehensive traceability system (PIC) and our Material Verification Program provides total accountability.
- **AUDIT SAVINGS** – Sourcing from Crosby enables you the opportunity to reduce your time and cost associated with your audits or third party audits. This is due to the fact that, by being ISO 9001 certified, Crosby is regularly audited by a third party.
- **WORLD COMPETITIVENESS** – Sourcing from Crosby will allow you to participate and be competitive in more markets throughout the world. Many major end users who operate on a worldwide level have already begun to require their suppliers be ISO 9000 certified or offer products that are produced by an ISO 9001 certified source.
- **A LONG TERM PARTNER** - Crosby's ability to meet ISO 9001 standards and to maintain third party certification makes it clear that the Crosby Group is a long term partner you can depend on to provide the needed product at required performance levels. The ISO 9001 certification forms a solid foundation from which we deliver all of the value added features represented by our Quality Continuum.
- **SUPPORT** – Crosby will support committed distributors in their efforts to define and accomplish what is needed for them to attain ISO 9002 certification.



*Crosby Group LLC; Tulsa, OK,  
Longview, TX, Jacksonville, AR,  
Putte, Mechelen, and Heist-op-den-Berg,  
Belgium, Ede, The Netherlands, West  
Midlands, England, Boulay and  
Joiny-sur-Meuse, France.*







# "There is No Equal"

The Market Leader: Yesterday Today and Tomorrow

## Identificatio

### PRODUCT IDENTIFICATION

The most effective method of assuring that the product you are purchasing is as reliable as possible is to purchase components supplied by companies of known reputation who maintain consistent and adequate quality. The company should clearly mark its components and finished products with the company name or logo, the component size or working load limit, and a code that is actively used by the manufacturer to control material and processes.

### THE COMPETITION

- Ask:** Do they have a traceability system?
- Ask:** If yes, is their traceability system also utilized for cast fittings, swage fittings an all load-bearing components?



Crosby forges the Product Identification Code (PIC), each item's size or Working Load Limit (or a cross-reference code to working load limit) and "Crosby" or its logo into each product.

**Load Rated**

### MATERIAL TRACEABILITY

A forged-in identification code should be used to record the material grade and origin. This record should trace the material to the heat lot of material of steel as rolled at the supplying mill. Verification checks of all materials purchased for forging must be done to insure that the steel supplied meets the specifications required. This verification should be traceable by a forged-in product identification code. In summary, the source and verification of material actually used in each forging must be able to be determined through appropriate documentation.

### THE COMPETITION

- Ask:** Do they have a permanently marked code in each product that traces material back to a verified certificatio
- Ask:** Do they test each heat of steel with their own testing facilities?



Crosby uses the Product Identification Code (PIC) to maintain material control from the steel mill, to receipt at our plant, to verification, and throughout the manufacturing process. Crosby can provide certified material analysis for each production lot, traceable by the Product Identification Code (PIC). Crosby, through its own laboratory, verifies the analysis of each heat of steel. Crosby purchases only special bar forging quality steel with specific cleanliness requirements and guaranteed hardenability.

### MANUFACTURING CONTROL

The permanent identification code should be used to maintain a record of which manufacturing facility produced the product as well as the approximate production dates. All quality records should reference the product identification code so that a history can be maintained. All product performance testing for audit and engineering purposes should also reference the product identification code.

### THE COMPETITION

- Ask:** Do their products have a permanent code that is used to maintain control as product is manufactured?



Crosby uses the Product Identification Code (PIC) to maintain control of its products as they are manufactured.

### PERFORMANCE & APPLICATION DATA

Detailed performance, application, and warning information will assist you in the proper use of products. This information is most effective when provided in supporting brochures and engineering information. An identification marking must be used to reference this information by use of a cross reference between the product code and the literature.

Proper performance data should include each item's working load limit, proof load and design factor. It should also include the item's manufacturing processes, such as heat treatment and galvanizing, and list any specification the product meets or exceeds.

### THE COMPETITION

- Ask:** What performance and application information do they provide?
- Ask:** Are there markings in products to aid in the proper use of the fitting
- Ask:** Is a comprehensive product warning system provided?
- Ask:** What training support is provided?



Crosby provides a detailed catalog that comprehensively describes each product's performance. The Crosby Product Warning System provides detailed application and warning information on selected products. In addition, training seminars and videos are also available. Selected products incorporate markings forged into the product to aid in the proper use of the fitting



**Remember: "When buying Crosby, you're buying more than product, you're buying Quality."**

## Identification and Labeling on the Product by Product Group

	Crosby Logo	Size	Working Load Limit	Rated in Metric Tons (t)	Product Identification Code	Serial Number	QUIC-CHECK® Markings	QUIC-CHECK® RFID Equipped
SHACKLES	X	X	X	X	X		X	25t and larger
SHANK HOOKS	X	Both size and working load limit are identified with a frame size that can be referenced back to our literature.		X	X			
EYE HOOKS	X	X	X	X	X			
OTHER FORGED HOOKS	X	X			X		S-322	
SNATCH BLOCKS	X	X	X	X	X*			4-1/2" and larger
CROSBY CLIPS	X	X			X*			
FIST GRIP CLIPS	X	X			X			
TURNBUCKLES	X	X			X			
LOAD BINDERS	X	X	X		X			
EYE BOLTS	X	X			X			
LINKS	X	X			X		X	
TAPERED SWIVEL BEARINGS	X	X		X	X			
CHAIN COMPONENTS	X	X			X			
SWAGE SOCKETS	X	X			X		X	
SLEEVES & BUTTONS	X	X			X			
380 BLOCK	McKissick	X	X		X	X		X
680 BLOCK	McKissick	X	X		X	X		X
OIL FIELD	McKissick	X	X		X	X		X
750 BRIDGE CRANE BLOCKS	McKissick	X	X	X		X		X
SHACKLES CT & 2160	X	X	X	X	X	X	CT Only	X
SWIVEL HOIST RINGS	X	X	X	Selected Sizes	X			X
ELIMINATOR CHAIN	X	X			X		X	
LIFTING CLAMPS	X	X	X	X		X		X
ANGULAR CONTACT SWIVEL BEARINGS	X	X	X		X			

\* Forged Components

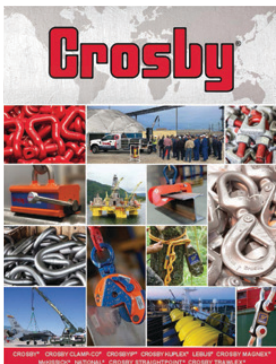

### GENERAL CATALOG

Our most comprehensive piece of literature. The Crosby general catalog contains detailed engineering specifications as well as definitions, illustrations, and drawings to assist in selecting the proper equipment for the job.



For CE-LABEL: Inquire for Full Details and Application Information.





# "There is No Equal"

The Market Leader: Yesterday Today and Tomorrow

## Heat Treatment

### HEAT TREATMENT

The heat treatment of steel is an ancient art science that dates back to the Iron Age. When strength and hardness of steel were needed, heat treatment provided the answer. Today the heat treatment of steel has been refined to a sophisticated science. It is now possible to greatly enhance the strength, ductility, and resilience of steel through a properly controlled heat treatment process. The "as forged" fitting results in variability that is detrimental in applications that require toughness. Normalizing, spheroidized annealing, and quench and tempering are heat treat processes. Proper heat treatment eliminates the risk of cooling variation at the forging process. This is true of all steels regardless of material grades.

### THE COMPETITION

**Ask:** Are load bearing fittings heat treated

**Ask:** If so, what type of heat treat process is used?

Some supply critical fittings in an "as forged" or "as cast" condition.



Crosby has fully qualified heat treat operations at its plants. Utilizing these facilities, Crosby heat treats all fittings that are load bearing components. Crosby minimizes risk by the effective heat treatment of its fittings. Heat treatment is an essential element of Crosby's Risk Management Program. We do not take shortcuts for the sake of cutting cost. For the benefit of reducing cost, a non heat treated product compromises the performance ability of the product. In addition, Crosby's metallurgical laboratory provides the support needed to assure the results.

### QUENCHED AND TEMPERED

Quenching and Tempering of steel has been found to be the heat treatment best suited to fully develop the strength and enhance the grain flow of carbon and alloy forgings. The quenched and tempered product will deform before ultimate failure, thus giving warning. The quenching process is rapid cooling in water or oil, after heating, to form a strong but brittle structure. The tempering process is the reheating of the steel to obtain the desired strength while increasing the ductility and toughness. Quench and tempering provides the consistency of performance needed by all critical applications, especially overhead lifting.

### THE COMPETITION

**Ask:** What products do they quench and temper?

**Ask:** Are their products that are exposed to high stress quenched and tempered?

**Ask:** If not, why are they willing to accept inferior impact and toughness properties of non quenched and tempered products?

Many normalize their forgings, but do not quench and temper.



Crosby fittings which are exposed to high stress applications and designed as load bearing elements are quenched and tempered. The Quench and Tempering process is the most consistent method of assuring that every fitting performs as needed, especially in overhead lifting.



### MATERIAL CONTROL

The proper heat treatment of forged fittings depends on the appropriate selection of materials and use of heat treat procedures. Fine grained, special bar forging quality steel of specific cleanliness requirements and guaranteed hardenability in the appropriate grades must be used. Proper selection of steel is NOT ENOUGH, however. The control and management of these steels, from purchase through the entire manufacturing process, is essential to assure that the proper results are attained in the designated product. This control should utilize a production traceability program.

### THE COMPETITION

**Ask:** Do they have identification code forged into the product that traces material back to verified certification

**Ask:** Are all heat records maintained by the traceability code?

Most do not provide traceability of material.



Crosby uses the Product Identification Code (PIC) for material control from receipt and verification of steel, and throughout the entire manufacturing process. Crosby can provide certified material analysis for each production lot

PIC  
Product Identification Cod

### ULTIMATE STRENGTH, DUCTILITY, IMPACT & FATIGUE PROPERTIES

The mechanical properties of steel when a load is very rapidly applied is known as its *impact* strength. Forged fittings must be able to have impact strengths that match the requirements of their application, especially in cold temperatures. The ability of a steel to withstand repeated applications of a load is measured by fatigue testing. The proper heat treatment of forgings, which includes quenching and tempering, can develop these properties to their desired level in a consistent and reliable manner. The ability to perform when overloaded is known as *ductility*.

### THE COMPETITION

**Ask:** Are the products designed and manufactured with considerations for strength, fatigue, impact, and ductility?

Some do not utilize materials that have good impact and fatigue properties.



Crosby's product line benefits from the selection of steel and the heat treatment process that allows for superior strength, ductility, impact, and fatigue performance. The product deforms if overloaded, giving warning before ultimate failure. All of these properties are essential if the product is to perform time after time. They are also important to assure that the inspection criteria set forth by ANSI will effectively monitor the ability of the fitting to continue in service

Remember: "When buying Crosby, you're buying more than product, you're buying Quality."



Heat Treatment Process by Product Groups	
PRODUCT	HEAT TREATMENT
SHACKLES	Bows - Quenched and Tempered Pins - Quenched and Tempered
EYE HOOKS	Quenched and Tempered
SHANK HOOKS	Quenched and Tempered
LINKS	Quenched and Tempered
RINGS	Quenched and Tempered
SWIVELS	Quenched and Tempered
TURNBUCKLES	All ends are Quenched and Tempered or Normalized Bodies Normalized
PAD EYES	Quenched and Tempered
EYE BOLTS	Quenched and Tempered
LOAD BINDERS	Quenched and Tempered
SWAGE SOCKETS	Spheroidized Annealed
SWAGE SLEEVES	Cold Tuff. A proprietary heat treat process that maximizes swageability of the sleeve at low temperatures.
SPELTER SOCKETS	Normalized

## MICROSTRUCTURES FOR VARIOUS HEAT TREATMENT PROCESSES

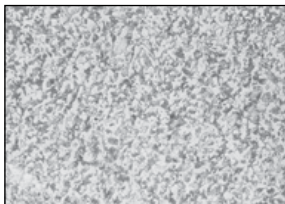

AS FORGED

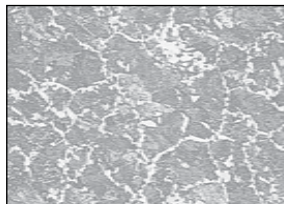

NORMALIZED

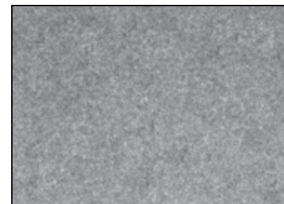

QUENCHED AND TEMPERED

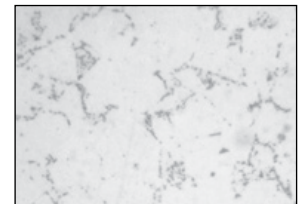

COLD TUFF®



*Remember: "When buying Crosby, you're buying more than product, you're buying Quality."*



# "There is No Equal"

The Market Leader: Yesterday Today and Tomorrow

## Material Properties

### PROCESS IS IMPORTANT

The material used in a forged fitting, such as carbon or alloy steel, determines the potential properties. The manufacturing processes determine what the properties will actually be. The material must be special bar forging quality steel and fine grained. The heating of steel to forging temperature must be properly controlled to insure that the steel is not "injured" by overheating. Proper forging equipment and techniques must be employed to assure proper material flow in the dies and tooling. The heat treatment process must be well defined and precisely controlled.

### THE COMPETITION

- Ask:** What processes do they consider important?
- Ask:** How do they select their material?
- Ask:** Is the steel fine grained
- Ask:** Are standards established to insure sufficient cleanliness of the steel



Crosby's attention to material selection, forging techniques, machining, and heat treatment processes assures the properties required will be attained, thus providing superior performance of the product. Crosby has specific and demanding cleanliness requirements. Crosby provides a video on metallurgy that highlights these facts.

### TENSILE STRENGTH & DUCTILITY

The mechanical properties that are important when lifting a load under normal conditions are tensile strength and ductility. The ability to carry a load increases with the tensile (pulling) strength of the steel. The ability of steel to deform in an overload condition is known as its ductility. Both of these factors enter greatly into determining the working load limit of a forging. Ductility is measured by standard engineering tests of elongation and reduction of area. It is also measured by how much deformation the fitting incurs when overloaded. The tensile strength determines the actual working load, while ductility allows the product to deform significantly when overloaded, thus giving warning before ultimate failure.

### THE COMPETITION

- Ask:** Do they have an active program to determine tensile and ductility properties?
- Ask:** Are testing audits performed continuously on all products?
- Ask:** Is the actual deformation of a fitting when overloaded a major consideration for their shackles?



Crosby has an active program to determine tensile and ductility properties. Testing audits are continuously performed on all products. Crosby's design philosophy considers the deformation of a fitting when loading is a key requirement

### FATIGUE PROPERTIES

The mechanical properties of steel when a load is repeatedly applied is known as its fatigue strength. Fatigue testing determines the ability of a material to withstand repeated applications of a load. The load by itself may be too small to produce a failure. There are three factors involved when considering fatigue strength. They are: the number of cycles at which a crack initiates, the number of cycles at which the crack starts to grow, and the number of cycles at which the fitting fails. One accepted method of fatigue rating fittings is to test them to 1-1/2 times the working load limit for 20,000 cycles, without failure. This standard test is accepted as indicating indefinite life when used within the working load limit under normal circumstances.

### THE COMPETITION

- Ask:** Does the material selection process recognize fatigue properties?
- Ask:** Do they have an active program to "design in" and test fatigue properties?
- Ask:** Is there a program in place to fatigue rate all load bearing products that are used in critical applications?



Crosby has an active program to determine fatigue properties. Included in this program is the use of finite element design methods to predict possible weak areas, which in turn allows us to design in superior fatigue properties. Crosby specifies material of specific cleanliness and guarantee hardenability which enhances fatigue. Crosby designs and manufactures its products with fatigue in mind. Crosby has a program in place that will result in all load bearing products used in critical applications being fatigue rated.

### IMPACT PROPERTIES

The mechanical properties of steel when a load is very rapidly applied is known as its impact strength. Impact tests are made by applying a sudden load to a test piece and measuring the energy absorbed when the specimen breaks. The "tougher" the material, the greater the energy required to break the piece. A brittle piece can absorb virtually no energy upon breaking. The Charpy V Notched Impact test is one common method of performing the testing and measurement. Fittings must be able to have impact strengths that match the requirements of their application at all temperatures, even low temperatures commonly found in winter conditions. The difficulty of crack initiation and crack growth under impact is an important consideration.

### THE COMPETITION

- Ask:** Does the material selection process recognize impact properties?
- Ask:** Do they have an active program to perform actual testing of impact properties?
- Ask:** Do they recognize the need for good impact properties, i.e., the need for crack initiation and growth to be difficult throughout the normal operating temperature of 0° to 75° F (-18°C + 24°C)?



Crosby recognizes the importance of impact properties and has an active program to determine impact properties at various temperatures of each material used in the various heat treat conditions. Crosby products are designed to be used in a wide range of temperatures. Crosby specifies material of specific cleanliness and guaranteed hardenability which enhances fatigue and impact properties.

### PERFORMANCE

Performance of a fitting requires a tensile strength that meets working load limits, ductility that allows deformation when overloaded, fatigue properties that support use time after time, and impact properties that provide toughness. All of these properties are essential if the product is to perform time after time in adverse conditions. They are also important to assure that the inspection criteria set forth by ANSI will effectively monitor the ability of the fitting to continue in service

### THE COMPETITION

- Ask:** Does the fitting have required tensile strength, ductility, fatigue and impact properties?
- Ask:** Are all the material properties met?



Crosby designs its fittings to include required working load limits and design factors. Equally important are the ductility, fatigue, and impact properties. Crosby provides you with material properties that minimize the risk of failure. No shortcuts in processing are made to save cost while sacrificing any of these performance elements.

## Material Properties by Product Groups

PROPERTY	DESCRIPTION	PRODUCT GROUP*
<b>TENSILE STRENGTH</b>	Crosby can provide typical hardness, tensile, and typical yield strength values.	Hooks, Shackles, Turnbuckles, and Chain Fittings
<b>DUCTILITY</b>	Crosby can provide typical reduction of area and elongation values upon special request.	Hooks, Shackles, Turnbuckles, and Chain Fittings
<b>IMPACT PROPERTIES</b>	Crosby's quenched and tempered products have enhanced impact properties for greater toughness at all temperatures. If requested at the time of order, Crosby can provide Charpy impact properties.	Hooks, Shackles, Turnbuckles, and Chain Fittings
<b>FATIGUE PROPERTIES</b>	Crosby products are being designed to meet specific fatigue performance levels. If requested at the time of order, these fatigue properties can be provided.	Hoist Hooks, Shackles, Eye Bolts, Turnbuckles, Swivel Hoist Rings, Chain Fittings and Snatch Blocks are Fatigue rated to 20,000 cycles at 1-1/2 times the Working Load Limit.
<b>PROOF TESTING</b>	Proof testing and certification are furnished standard with some products. If requested at the time of order, proof testing certification can be provided on most of Crosby's remaining product line, with the exception of products such as swage sockets and sleeves, spelter sockets, thimbles, etc.	All Products
<b>QC 1400 AUDITS</b>	Crosby's QC 1400 program provides reduction of area, elongation values, as well as hardness, tensile, and yield strength values for each production lot of hoist hooks. These factors are traceable by the Product Identification Code (PIC) program.	Hoist Hooks Only
<b>MAG CERTIFICATION, ULTRA SONIC, X-RAY, AND DYE PENETRANT TESTING</b>	If requested at the time of order, different non-destructive testing and certification is available	All Products
<b>CHEMISTRY ANALYSIS</b>	Each heat of steel is individually verified to confirm chemical analysis prior to manufacturing.	All Products

\* Products listed are those most commonly requested to be provided with specified properties. The material properties may also be available on other products upon request.





# Crosby®

... in the future, as in the past, look to Crosby for innovation, education and product leadership.

Since 1889 The Crosby Group has been driven to become the single source for accessories used in the lifting and material handling industry. Growing through product development, uncompromising quality and aggressive acquisitions of market leading companies, Crosby moves forward towards this goal.





Understanding:

---

# The Crosby Group Product Warnings



# Product Warning and Application Information and Their Importance to You.

*“Men who value lives and loads . . .”* is more than just a slogan to the Crosby Group. It is a constant reminder to us that our products are often in work environments which can be dangerous. It is also a constant reminder that our products must remain of the highest quality and design.

Our products are used as components of a *“Work System”* for lifting, towing, tying down, and hauling. Used properly in such a *“Work System,”* Crosby products have been proven to be among the best designed and safest in our industry. Used improperly, however, a *“Work System”* can be rendered inefficient and unsafe. It is absolutely critical that those who use our products be trained in how to use them correctly. Designing and fabricating rigging properly requires specialized training. If you or your employees lack proper training in approved rigging practices, **DO NOT ATTEMPT TO DESIGN OR FABRICATE ANY RIGGING.**

In addition to providing high quality products, we also provide warning and application instructions for our products. These warnings and instructions are only a portion of our entire customer communication system that we use to disseminate information concerning product warnings and application instructions.

These warnings and application instructions are reviewed and discussed with Distributors and End Users, and revised when appropriate. Our commercial literature discusses Safety issues before presenting any other product information. We provide product safety literature to our Distributor network for sharing with their customers. It would be impossible for any warnings to contain all of the possible misapplication associated with the use of Crosby products. Crosby warnings are intended to identify only those risks which are most common. As a rigging or designer of rigging, it is your explicit responsibility to consider the risk factors prior to putting any rigging device or products into use.

We have also produced the brochure *“Understanding: The Crosby Group Product Warnings”* to further enhance our existing warning and application instructions. We strongly recommend that you read it, use it in your Safety Training Programs, and make it available to the product users such as your customers and those who work in your facilities. If you would like to receive additional copies, please contact your Crosby Group Representative or contact us direct at the address shown in the front of this catalog or telephone us at (1-800-772-1500).

Working together, we can ensure that *“Men who value lives and loads”* will continue to use Crosby products confidently and safely .

***Remember: “When buying Crosby, you’re buying more than product, you’re buying Quality.”***



# CROSBY WARNING ELEMENTS

Let's turn to the basic elements and formats of the Crosby Group warnings. In most Crosby warnings, four basic elements or types of information are provided:

1. A "Signal Word" such as "DANGER", "WARNING", or "CAUTION." This word is meant to attract the attention of the user to the warning statement. The signal word also identifies the degree of potential danger or risk in using the product.
2. A "Hazard Statement" such as "FAILURE TO USE TACKLE BLOCK CORRECTLY MAY CAUSE LOAD TO SLIP OR FALL." This statement is meant to inform or remind the user of factors involved in the task or work environment that can create a hazard.
3. A "Consequence Statement" such as "FAILURE TO FOLLOW APPLICATION INSTRUCTIONS MAY RESULT IN SERIOUS INJURY OR DEATH." This statement is meant to inform or remind the user that failure to avoid the hazard can have harmful consequences.
4. An "Instruction Statement" such as "PREPARE WIRE ROPE TERMINATION ONLY AS INSTRUCTED." This statement is meant to inform or remind the user of the proper steps or procedures for using the product safely and avoiding the hazard.

## SIGNAL WORDS

In Crosby warnings, a "signal word" is used to attract attention of the user to the warning. As indicated below, another purpose of the signal word is to identify the level of risk or hazard involved. Sometimes, the signal word will be accompanied by a "safety alert symbol" such as an exclamation point inside a triangle. As discussed later in this catalog, the signal word will always appear within a box or panel separated from the remainder of the warning by a border and, in some cases, may have a contrasting background color such as red, orange, or yellow. The majority of Crosby warnings use the signal words:



This indicates a situation in which a hazard is imminent and will result in a high probability of serious injury or death.



This indicates a potential hazardous situation which could result in some probability of serious injury or death.



This indicates a potential hazardous situation which could result in minor injury or moderate injury.

Crosby warnings use these signal words for alerting product users to potential hazards which can result in personal injury or death. For hazards involving potential damage to property, Crosby uses other signal words such as "IMPORTANT" or "NOTICE."

# WARNING COLOR CODES

Some Crosby warnings will use a contrasting color within the warning to reinforce the word message and/or to attempt to draw attention of the user to the warning message. When colors are used for these purposes, they will appear as background for the signal word panel.

Three colors are used in the Crosby warning system:

<b>RED</b>
<p>This will appear in some warnings which use the signal word "DANGER," indicating the highest degree of risk. When red is used in the signal word panel, white letters are used for the word "DANGER." If a safety alert symbol is used along with the signal word, such as an exclamation mark inside of a triangle, the triangle will be solid white and the exclamation mark will be red.</p>

<b>ORANGE</b>
<p>This will appear in some warnings which use the signal word "WARNING." When orange is used in the signal word panel, black letters are used for the word "WARNING." If a safety alert symbol is used along with the signal word, such as an exclamation mark inside of a triangle, the triangle will be solid black and the exclamation mark will be orange.</p>

<b>YELLOW</b>
<p>This will appear in some warnings which use the signal word "CAUTION." When yellow is used in the signal word panel, black letters are used for the word "CAUTION." If a safety alert symbol is used along with the signal word, such as an exclamation mark inside of a triangle, the triangle will be solid black and the exclamation mark will be yellow.</p>

# WARNING FORMAT

Crosby warnings on tags, labels, and within application instructions are displayed in a similar format. Warnings are usually set apart from other information by a border, contrasting color, or both. Typically, Crosby warnings are displayed in a "box," set apart by a border, and consisting of two or three "panels within the box." Specifically

- The signal word (and alert symbol if used) appears in the upper panel of the box.
- The hazard statement, consequence statement, and instruction statement appears in the lower panel of the box.
- In a warning which uses three panels, the third panel will be pictorial which also identifies the hazard or indicates how to avoid the hazard

Here is an example of the Crosby Warning for Forged Eye Bolts, demonstrating the alert, hazard, consequence and instruction elements:

<b>SIGNAL WORD / ALERT SYMBOL</b>		 <b>WARNING</b>
<b>HAZARD &amp; CONSEQUENCE STATEMENT</b>		<ul style="list-style-type: none"> <li>● Loads may slip or fall if proper eye bolt assembly and lifting procedures are not used.</li> <li>● A falling load can seriously injure or kill.</li> <li>● Read, understand these instructions, and follow all eye bolt safety information presented here.</li> <li>● Read, understand, and follow information in diagrams and charts below before using eye bolt assemblies.</li> </ul>
<b>INSTRUCTION STATEMENT</b>		

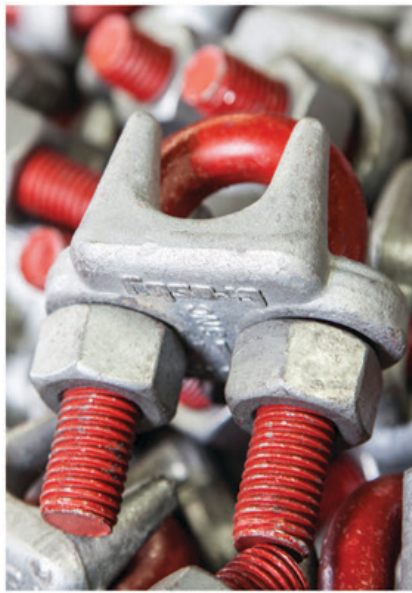

# WIRE ROPE END FITTINGS

With Product Warning and Application Information





G-450



"There is No Equal"

The Market Leader: Yesterday Today and Tomorrow



G-429

## Wire Rope End Fittings

### FORGED FOR CRITICAL APPLICATIONS

The proper performance of forged clips depends on proper manufacturing practices that include good forging techniques and accurate machining. Forged clips provide a greater rope bearing surface and more consistent strength than malleable cast iron clips. Fist Grip clips provide a saddle for both the "live" and the "dead" end. Fewer forged clips are required for each termination than with malleable cast iron clips. Forged clips reduce the possibility of hidden defects that are sometimes present in malleable cast iron clips. Malleable cast iron clips should only be used in non-critical applications. ASME, OSHA, and ASTM recommend only forged clips for critical applications.

### THE COMPETITION

- Ask:** *Is the clip forged?*
- Ask:** *Is an adequate cradle provided in the clip base for the wire rope?*

Malleable cast iron clips are sometimes improperly used as replacements for forged clips.



Crosby provides forged "Red" U-Bolt® Clips and forged Fist Grip clips which meet or exceed Federal Specification Number FF-C-450E and are considered the industry standard.

### FULL LINE

The proper application of forged clips requires that the correct type, size, number, and installation instructions be used (See APPLICATION INFORMATION below for more information). Availability of a full range of sizes of forged U-bolt clips and forged Fist Grip clips are essential for design flexibility.

### THE COMPETITION

- Ask:** *Do they have both Fist Grip and U-bolt clips available?*
  - Ask:** *Do they have a full range of forged wire rope clip sizes?*
- No competitor has the full line of forged U-Bolt clips and Fist Grip clips that Crosby has.



Only Crosby provides forged "Red" U-Bolt® Clips from 1-1/8" to 3-1/2" and forged Fist Grip clips from 3/16" to 1-1/2".

\* The 3-1/2" base is a steel casting.

### IDENTIFICATION

The clip's size, manufacturer's logo, and a traceability code should be clearly embossed in the forging of the clip. These three elements are essential in developing total confidence in the product.

### THE COMPETITION

- Ask:** *Is the manufacturer's name and size of clip clearly marked?*
- Ask:** *Do they have a traceability system that is actively used in the manufacturing process?*

Most do not have a traceability system.



Crosby clearly embosses its logo, the size, and the Product Identification Code (PIC) into all Crosby "Red" U-bolt® Clip bases and Fist Grip clips. Crosby's traceability system is actively used throughout the manufacturing of forged clips. The material analysis for each heat of steel is verified within our own laboratory.

### APPLICATION INFORMATION

Detailed application information will assist you in the proper installation of wire rope clips. This information is most effective when provided at the point of application, as well as in supporting brochures and engineering information. The manufacturer must provide this specific information. Generic information will not provide all the needed application instructions. A formal application and warning system that attracts the attention of the user, clearly informs the user of the factors involved in the task, and informs the user with the proper application procedures as needed.

### THE COMPETITION

- Ask:** *Does each clip have the application and warning information?*
- Most competitors do not have application and warnings information with each clip.



Crosby provides detailed application and warning information for all forged clips. Each clip is individually bagged or tagged with the application and warning information. Testing and evaluation of special applications can be performed upon special request.

**Remember: "When buying Crosby, you're buying more than product, you're buying Quality."**

- **Full Line:** Crosby provides both forged "Red" U-Bolt® Clips and forged Fist Grip Clips.
- **Forged:** Crosby "Red" U-Bolt® Clips have forged bases on all sizes, except 2-3/4" and 3-1/2" base is a steel casting. The entire clip is galvanized to resist corrosive and rusting action. Clip sizes 1/8" through 1-1/2" have U-Bolts with rolled threads which enhance the strength of the material and fatigue properties.
- **Forged:** Fist Grip Clips are forged, and the entire clip is galvanized. The double saddle design eliminates the possibility of incorrect installation. Designed as an integral part of the clip, the bolts are opposite one another (see G-429 example below). As result, the nuts can be installed in such a way as to enable the operator to swing the wrench in a full arc for ease of installation.
- **Application Information:** Application and warning information is available for both Crosby "Red" U-Bolt® Clips and Fist Grip Clips. The Crosby Warning System is designed to attract the attention of the user, clearly inform the user of the factors involved in the task, and provide the user with proper application procedures. Each Crosby "Red" U-Bolt® Clip and Fist Grip Clip is either bagged or tagged with appropriate application and warning information, thus ensuring that the information is available at the point of application for each and every clip during installation.
- **Material Analysis:** Crosby can provide certified material (mill) analysis for each production lot, traceable by the Product Identification Code (PIC). Crosby, through its own laboratory, verifies the analysis of each heat of steel.
- **Testing:** Crosby periodically audits the termination efficiencies of the "Red" U-Bolt Clips and Fist Grip Clips. Upon special request, Crosby will determine the efficiencies of clip assemblies when applied to special rope constructions and special applications.

G-450



G-429



S-421T



S-423T



G-517



G-416



G-417



S-409



S-501



S-502



S-505



S-319SWG





**G-450**

**Red-U-Bolt® Clip**

Crosby Clips, all sizes 1/4" and larger, meet the performance requirements of Federal Specification FF-C-450E TYPE 1 CLASS 1, except for those provisions required of the contractor. For additional information, see page 452.

- Each base has a Product Identification Code (PIC) for material traceability, the name CROSBY or CG, and a size forged into it.
- Based on the catalog breaking strength of wire rope, Crosby wire rope clips have an efficiency rating of 80% for 1/8" through 7/8" sizes, and 90% for sizes 1" through 3-1/2".
- Entire Clip is Galvanized to resist corrosive and rusting action.
- Sizes 1/8" through 2-1/2" and 3" have forged bases.
- All Clips are individually bagged or tagged with proper application instructions and warning information.
- Clip sizes up through 1-1/2" have rolled threads.
- Meets or exceeds all requirements of ASME B30.26 including identification, ductility, design factor, proof load and temperature requirements. Importantly, these wire rope clips meet other critical performance requirements including fatigue life, impact properties and material traceability, not addressed by ASME B30.26.
- Look for the Red-U-Bolt®, your assurance of Genuine Crosby Clips.



**G-450 Crosby Clips**

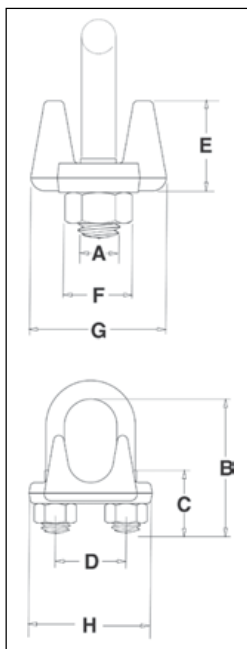

Rope Size		G-450 Stock No.	Std. Package Qty.	Weight Per 100 (lb)	Dimensions (in)							
(in)	(mm)				A	B	C	D	E	F	G	H
1/8	3-4*	1010015	100	6	.22	.72	.44	.47	.37	.38	.81	.99
3/16*	5*	1010033	100	10	.25	.97	.56	.59	.50	.44	.94	1.18
1/4	6-7	1010051	100	19	.31	1.03	.50	.75	.66	.56	1.19	1.43
5/16	8	1010079	100	28	.38	1.38	.75	.88	.73	.69	1.31	1.66
3/8	9-10	1010097	100	48	.44	1.50	.75	1.00	.91	.75	1.63	1.94
7/16 - 1/2	11-13	1010131	50	80	.50	1.88	1.00	1.19	1.13	.88	1.91	2.28
9/16 - 5/8	14-16	1010177	50	110	.56	2.25	1.25	1.31	1.34	.94	2.06	2.50
3/4	18-20	1010195	25	142	.62	2.75	1.44	1.50	1.39	1.06	2.25	2.84
7/8	22	1010211	25	212	.75	3.12	1.62	1.75	1.58	1.25	2.44	3.16
1	24-26	1010239	10	252	.75	3.50	1.81	1.88	1.77	1.25	2.63	3.47
1-1/8	28-30	1010257	10	283	.75	3.88	2.00	2.00	1.91	1.25	2.81	3.59
1-1/4	32-34	1010275	10	438	.88	4.44	2.22	2.34	2.17	1.44	3.13	4.13
1-3/8	36	1010293	10	442	.88	4.44	2.22	2.34	2.31	1.44	3.13	4.19
1-1/2	38	1010319	10	544	.88	4.94	2.38	2.59	2.44	1.44	3.41	4.44
1-5/8	41-42	1010337	Bulk	704	1.00	5.31	2.62	2.75	2.66	1.63	3.63	4.75
1-3/4	44-46	1010355	Bulk	934	1.13	5.75	2.75	3.06	2.92	1.81	3.81	5.24
2	48-52	1010373	Bulk	1300	1.25	6.44	3.00	3.38	3.03	2.00	4.44	5.88
2-1/4	56-58	1010391	Bulk	1600	1.25	7.13	3.19	3.88	3.19	2.00	4.56	6.38
2-1/2	62-65	1010417	Bulk	1900	1.25	7.69	3.44	4.13	3.69	2.00	4.69	6.63
** 2-3/4	** 68-72	1010435	Bulk	2300	1.25	8.31	3.56	4.38	4.88	2.00	5.00	6.88
3	75-78	1010453	Bulk	3100	1.50	9.19	3.88	4.75	4.44	2.38	5.31	7.61
** 3-1/2	** 85-90	1010426	Bulk	4000	1.50	10.75	4.50	5.50	6.00	2.38	6.19	8.38

\* Electro-plated U-Bolt and Nuts. \*\* 2-3/4" and 3-1/2" base is made of cast steel.



# Fist Grip® Wire Rope Clips



**G-429**  
Fist Grip® Clip  
3/16" - 5/8"

Fist Grip® wire clips meet or exceed the performance requirements of Federal Specification FF-C-450E Type III, Class 1, except for those provisions required of the contractor. For additional information, see page 452.

- Entire clip is Galvanized to resist corrosive and rusting action.
- Based on the catalog breaking strength of wire rope, Crosby wire rope clips have an efficiency rating of 80% for 3/16" through 7/8" sizes, and 90% for sizes 1" through 1-1/2"
- Bolts are an integral part of the saddle. Nuts can be installed in such a way as to enable the operator to swing the wrench in a full arc for fast installation.
- All sizes have forged steel saddles.
- All Clips are individually bagged or tagged with proper application instructions and warning information.
- Meets or exceeds all requirements of ASME B30.26 including identification, ductility, design factor, proof load and temperature requirements. Importantly, these wire rope clips meet other critical performance requirements including fatigue life, impact properties and material traceability, not addressed by ASME B30.26.
- Assembled with standard heavy hex nuts.



**G-429**  
Fist Grip® Clip  
3/4" - 1-1/2"

Wire Rope  
End Fittings

3/16" - 5/8"

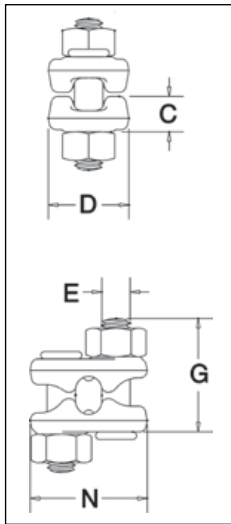

3/4" - 1-1/2"

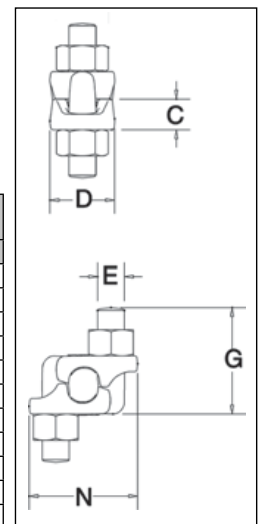

## G-429 Fist Grip® Clips

Rope Size		G-429 Stock No.	Std. Package Qty.	Weight Per 100 (lb)	Dimensions (in)				
(in)*	(mm)				C	D	E	G	N
3/16 - 1/4	5-7	1010471	100	23	.40	.94	.38	1.41	1.44
5/16	8	1010499	100	28	.47	1.06	.38	1.50	1.54
3/8	10	1010514	50	40	.51	1.06	.44	1.84	1.78
7/16 - 1/2	11-13	1010532	50	62	.59	1.25	.50	2.21	2.15
9/16 - 5/8	14-16	1010550	50	103	.72	1.50	.63	2.72	2.57
3/4	18-20	1010578	25	175	.86	1.81	.75	2.94	2.67
7/8	22	1010596	25	225	.97	2.12	.75	3.31	2.86
1	24-26	1010612	10	300	1.13	2.25	.75	3.72	3.06
1-1/8	28-30	1010630	10	400	1.28	2.38	.88	4.22	3.44
1-1/4	32-34	1010658	10	400	1.34	2.50	.88	4.25	3.56
1-3/8 - 1-1/2	36-40	1010676	Bulk	700	1.56	3.00	1.00	5.56	4.12

\* Sizes through 5/8" incorporate New Style Design.

**WIRE ROPE CLIPS  
TRAINING VIDEO**  
CROSBY G-450 & G-429



[youtube.com/thecrosbygroup](https://youtube.com/thecrosbygroup)

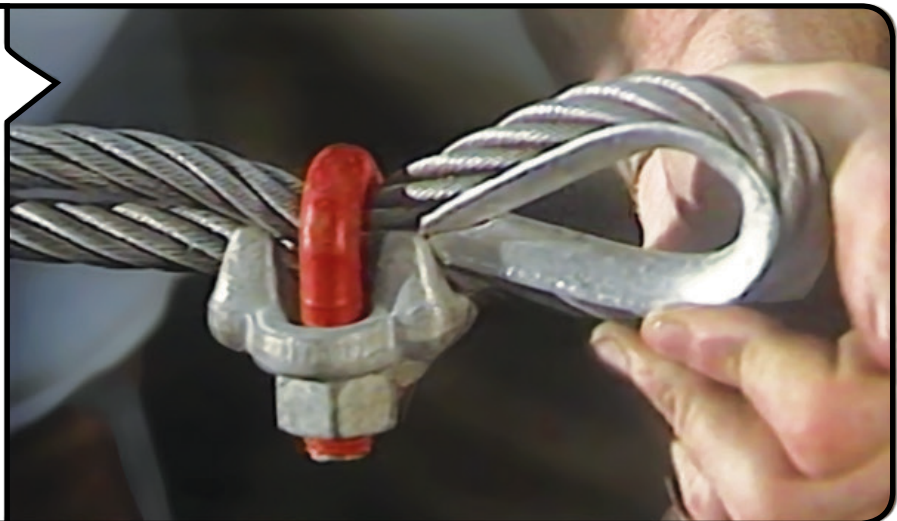



**S-421T**

Wedge sockets meet the performance requirements of Federal Specification RR-S-550F, Type C, except those provisions required of the contractor. For additional information, see page 452.

- Wedge socket terminations have an efficiency rating of 80% based on the catalog strength of XXI wire rope.
- Meets or exceeds all requirements of ASME B30.26 including identification, ductility, design factor, proof load and temperature requirements. Importantly, these sockets meet other critical performance requirements including fatigue life, impact properties and material traceability, not addressed by ASME B30.26.
- Type Approval certification in accordance with ABS RULES FOR CONDITIONS OF CLASSIFICATION, PART 1 2017 STEEL VESSELS AND ABS GUIDE FOR CERTIFICATION OF LIFTING APPLIANCES 2017 available. Certificates available when requested at time of order and may include additional charges
- Basket is cast steel and individually magnetic particle inspected.
- Pin diameter and jaw opening allows wedge and socket to be used in conjunction with closed swage and spelter sockets.
- Secures the tail or “dead end” of the wire rope to the wedge, thus eliminates loss or “Punch out” of the wedge.
- Eliminates the need for an extra piece of rope, and is easily installed.
- The TERMINATOR™ wedge eliminates the potential breaking off of the tail due to fatigue.
- The tail, which is secured by the base of the clip and the wedge, is left undeformed.
- Incorporates Crosby’s patented QUIC-CHECK® “Go” and “No-Go” feature cast into the wedge. The proper size rope is determined when the following criteria are met:
  - 1) The wire rope should pass thru the “Go” hole in the wedge.
  - 2) The wire rope should NOT pass thru the “No-Go” hole in the wedge.
- Utilizes standard Crosby Red-U-Bolt® wire rope clip.
- The 3/8 through 1-1/8 standard S-421 wedge socket can be retrofitted with the new style TERMINATOR wedge.
- **Available with Bolt, Nut, and Cotter Pin.**
- U.S. patent 5,553,360, Canada patent 2,217,004 and foreign equivalents.
- Meets the performance requirements of EN 13411-6.
- Available with API-2C certification upon request

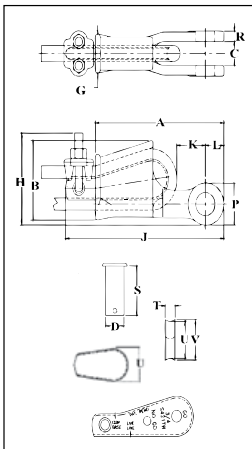

Scan this QR code with your smart device to view our Terminator video.



SEE APPLICATION AND WARNING INFORMATION

Page 58  
Para Español: [www.thecrosbygroup.com](http://www.thecrosbygroup.com)

**S-421T WEDGE SOCKETS** (Assembly includes Socket, Wedge, Pin and Wire Rope Clip)

Wire Rope Dia.		S-421T Stock No.	Weight Each (lb)	Wedge Only	Weight Each (lb)	Standard Bolt, Nut & Cotter Assy	Weight Each (lb)
(in)	(mm)						
3/8	9-10	1035000	3.30	1035555	.50	2038971	.38
1/2	11-13	1035009	6.10	1035564	1.05	2038972	.69
5/8	14-16	1035018	10.5	1035573	1.79	2038974	1.15
3/4	18-19	1035027	16.4	1035582	2.60	2038976	1.91
7/8	20-22	1035036	24.8	1035591	4.00	2038978	3.23
1	24-26	1035045	35.5	1035600	5.37	2038980	5.40
1-1/8	28	1035054	48.8	1035609	7.30	2038982	7.50
1-1/4	30-32	1035063	71.5	1035618	10.60	2038984	10.34

Wire Rope Dia.		S-421T Stock No.	S-421TB Stock No.	Dimensions (in)														
(in)	(mm)			A	B	C +/- .09	D	G	H	J*	K*	L	P	R	S	T	U	V
3/8	9-10	1035000	1035203	5.69	2.72	.81	.81	1.38	3.06	7.80	1.88	.88	1.56	.44	2.13	.44	1.25	1.38
1/2	11-13	1035009	1035212	6.88	3.47	1.00	1.00	1.62	3.76	8.91	1.26	1.06	1.94	.50	2.56	.53	1.75	1.88
5/8	14-16	1035018	1035221	8.25	4.30	1.25	1.19	2.12	4.47	10.75	1.99	1.22	2.25	.56	3.25	.69	2.00	2.19
3/4	18-19	1035027	1035230	9.88	5.12	1.50	1.38	2.44	5.28	12.36	2.41	1.40	2.63	.66	3.63	.78	2.34	2.56
7/8	20-22	1035036	1035249	11.25	5.85	1.75	1.63	2.69	6.16	14.37	2.48	1.67	3.13	.75	4.31	.88	2.69	2.94
1	24-26	1035045	1035258	12.81	6.32	2.00	2.00	2.94	6.96	16.29	3.04	2.00	3.75	.88	4.70	1.03	2.88	3.28
1-1/8	28	1035054	1035267	14.38	6.92	2.25	2.25	3.31	7.62	18.34	2.56	2.25	4.25	1.00	5.44	1.10	3.25	3.56
1-1/4	30-32	1035063	1035276	16.34	8.73	2.62	2.50	3.56	9.39	20.48	2.94	2.34	4.50	1.06	6.13	1.19	4.62	4.94

\* Nominal **NOTE:** For intermediate wire rope sizes, use next larger size socket. The S-423T Super TERMINATOR wedge is designed to be assembled only into the Crosby S-421T TERMINATOR socket body. **IMPORTANT:** The S-423TW for sizes 5/8" through 1-1/8" (14mm through 28mm) will fit respective size standard Crosby S-421T basket. The 1-1/4" (30-32mm) S-423TW will only fit the Crosby S-421T 1-1/4" basket marked with TERMINATOR.

# US-422T Utility Wedge Sockets



## US-422T

Most sizes now incorporate the Crosby TERMINATOR design and may vary in shape from above product shown.

- Basket is cast steel and individually magnetic particle inspected.
- Wedge socket terminations have an efficiency rating of 80% based on the catalog strength of XXI wire rope.
- Wedges are color coded for easy identification
  - Blue - largest wire line size for socket.
  - Black - mid size wire line for socket.
    - 7/16" on US4
    - 9/16" on US5
  - Orange - smallest wire line size for socket.
- Cast into each socket is the name "McKissick", "Crosby" or "CG", its model number and its wire line range.
- By simply changing out the wedge, each socket can be utilized for various wire line sizes (Ensure correct wedge is used for wire rope size).
- Cast into each wedge is the model number of the socket and the wire line size for which the wedge is to be used.
- Load pin is forged and headed on one end.
- Incorporates Crosby's patented QUIC-CHECK® "Go" and "No-Go" feature cast into the wedge. The proper size rope is determined when the following criteria are met:
  - 1) The wire rope should pass thru the "Go" hole in the wedge.
  - 2) The wire rope should NOT pass thru the "No-Go" hole in the wedge.
- US-422T wedge sockets contain a hammer pad (lip) to assist in proper securement of termination.
- Meets or exceeds all requirements of ASME B30.26 including identification, ductility, design factor, proof load and temperature requirements. Importantly, these sockets meet other critical performance requirements including fatigue life, impact properties and material traceability, not addressed by ASME B30.26.
- UWO-422T Wedges are to be used only with the US-422T Wedge Socket Assemblies.
- Available with API-2C certification upon request

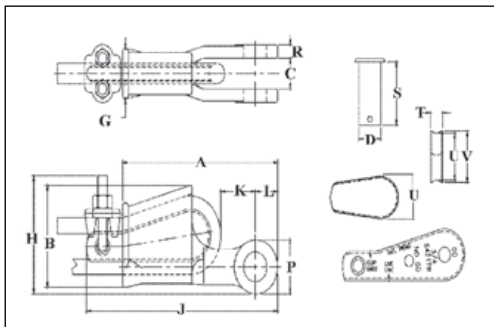

Scan this QR code with your smart device to view our Terminator video.



## US-422T Utility Wedge Sockets

Model No.	Wire Rope Size		US-422T Stock No.	Weight Each (lb)	Wedge Only Stock No.	Weight Each (lb)	Dimensions (in)														
	(in)	(mm)					A	B	C +/- .09	D	G	H	J	K	L	P	R	S	T	U	V
US4T	3/8	10	1044300	4.6	1047310	.6	6.81	3.55	1.00	1.00	1.63	2.81	8.43	1.38	1.06	1.94	.50	2.53	.44	1.91	2.14
US4T	7/16	11	1044309	4.6	1047301	.6	6.81	3.55	1.00	1.00	1.63	2.81	8.73	1.08	1.06	1.94	.50	2.53	.53	1.76	1.88
US4T	1/2	13	1044318	4.6	1047329	.6	6.81	3.55	1.00	1.00	1.63	2.81	8.73	1.02	1.06	1.94	.50	2.53	.53	1.76	1.88
US5T	1/2	13	1044327	8.5	1047338	1.0	9.19	4.23	1.41	1.25	2.13	3.31	11.19	1.84	1.50	3.00	.63	3.25	.75	1.92	2.16
US5T	9/16	14	1044336	8.5	1047347	1.0	9.19	4.23	1.41	1.25	2.13	3.31	11.47	2.40	1.50	3.00	.63	3.25	.69	2.00	2.18
US5T	5/8	16	1044345	8.5	1047356	1.0	9.19	4.23	1.41	1.25	2.13	3.31	11.47	2.34	1.50	3.00	.63	3.25	.69	2.00	2.18
US6T	5/8	16	1044354	9.4	1047365	1.4	9.45	4.70	1.50	1.25	2.24	3.63	11.91	2.48	1.50	3.00	.56	3.25	.88	2.38	2.75
US6T	3/4	19	1044363	9.4	1047374	1.4	9.45	4.70	1.50	1.25	2.24	3.63	11.81	2.03	1.50	3.00	.56	3.25	.88	2.13	2.63
US8AT	5/8	16	1044372	19.8	1047383	4.3	10.59	5.68	1.81	1.63	2.38	5.53	13.19	1.91	1.53	2.88	.75	4.13	.69	3.26	3.50
US8AT	3/4	19	1044381	20.4	1047392	4.8	10.59	5.68	1.81	1.63	2.38	5.84	13.54	2.38	1.53	2.88	.75	4.13	.78	3.12	3.38
US7*	7/8	22	1038580	16.5	1046674	2.6	11.26	5.11	1.31	1.25	2.69	—	—	2.56	1.63	3.26	.66	3.25	1.06	2.12	2.56
US7*	1	25	1038589	16.5	1046683	2.6	11.26	5.11	1.31	1.25	2.69	—	—	2.56	1.63	3.26	.66	3.25	1.06	1.88	2.38
US8T	7/8	22	1044404	31.5	1047425	7.6	12.77	6.96	1.81	1.63	3.06	7.20	16.02	2.87	1.65	3.12	.75	4.13	.88	3.88	4.18
US8T	1	25	1044417	32.5	1047431	8.6	12.77	6.96	1.81	1.63	3.06	7.31	16.41	2.32	1.65	3.12	.75	4.13	1.03	3.76	4.06
US10T	1-1/8	28	1044426	55.4	1047440	12.5	15.94	8.62	1.81	1.63	3.57	9.15	19.72	3.26	2.19	4.38	.75	4.13	1.09	4.76	5.06
US10T	1-1/4	32	1044435	58.0	1047459	15.0	15.94	8.62	1.81	1.63	3.57	9.39	20.22	2.83	2.19	4.38	.75	4.13	1.19	4.62	4.94
US11T	1-1/8	28	1044444	60.6	1047468	12.5	16.34	8.73	2.62	2.50	3.56	9.15	19.97	3.37	2.34	4.50	1.06	6.13	1.09	4.76	5.06
US11T	1-1/4	32	1044453	64.9	1047477	15.0	16.34	8.73	2.62	2.50	3.56	9.39	20.48	2.94	2.34	4.50	1.06	6.13	1.19	4.62	4.94

\* Non-TERMINATOR Style.



The Crosby S-423T Super TERMINATOR is the first wedge socket designed to take advantage of the performance properties associated with high performance, high strength, compacted strand, rotation resistant wire rope.

**The Crosby Super TERMINATOR offers several advantages over traditional methods of wedge socket terminations:**

- The innovative design will significantly increase the termination efficiency over existing wedge sockets available today.
- Terminations on most ropes have a minimum efficiency rating of 80% of the rope's catalog breaking strength.
- Design eliminates the difficulty of properly seating the wedge with high performance, high strength, compacted strand, rotation resistant wire rope into a wedge socket termination.
- Proper application of the Super TERMINATOR eliminates the "first load" requirement of conventional wedge socket terminations.
- US Patent 8,375,527 B1.

**Additional Features:**

- Wire rope sizes available: 5/8" through 1 1/4," 14mm through 32mm.
- Available as a complete assembly, or as a wedge kit that can be retrofitted onto existing Crosby S-421T TERMINATOR wedge sockets.
- Wedge accessories provided with a zinc finish.
- Meets or exceeds all ASME B30.26 requirements including: identification, ductility, design factor, proof load, and temperature requirements. Importantly, they meet other critical performance criteria not addressed by ASME B30.26 including: fatigue life, impact properties and material traceability.
- Available with bolt, nut and cotter (S-423TB).

**The Super TERMINATOR by Crosby.  
The first wedge socket termination  
designed specifically for high  
performance wire rope.**

**S-423T  
Super  
Terminator**



**Crosby**<sup>®</sup>

thecrosbygroup.com

# S-423T Super Terminator



## S-423T

Wedge sockets meet the performance requirements of Federal Specification RR-S-550F, Type C, except those provisions required of the contractor. For additional information, see page 452 of General Catalog.

- The 423T wedge socket terminations have a minimum efficiency rating on most high performance, high strength, compacted strand, rotation resistant wire ropes of 80% based on the catalog breaking strength of the various ropes.\*\*
- Design eliminates the difficulty of properly seating the wedge with high performance wire rope into a wedge socket termination.
- Proper application of the Super TERMINATOR eliminates the "first load" requirement of conventional wedge socket terminations.
- S-423TW Wedge Kit can be retrofitted onto existing Crosby S-421 TERMINATOR wedge sockets.
- Wedge and accessories provided with a zinc finish
- Meets the performance requirements of EN13411-6.
- Meets or exceeds all requirements of ASME B30.26 including identification, ductility, design factor, proof load and temperature requirements. Importantly, these sockets meet other critical performance requirements including fatigue life, impact properties and material traceability, not addressed by ASME B30.26.
- US Patent 6,898,827.
- Basket is cast steel and individually magnetic particle inspected.
- Pin diameter and jaw opening allows wedge and socket to be used in conjunction with closed swage and spelter sockets.
- Secures the tail or "dead end" of the wire rope to the wedge, thus eliminates loss or "punch out" of the wedge.
- Eliminates the need for an extra piece of rope, and is easily installed.
- The TERMINATOR® wedge eliminates the potential breaking off of the tail due to fatigue.
- The tail, which is secured by the base of the clip and the tension device, is left undeformed.
- Available with Bolt, Nut, and Cotter Pin.
- Available with API-2C certification upon request.

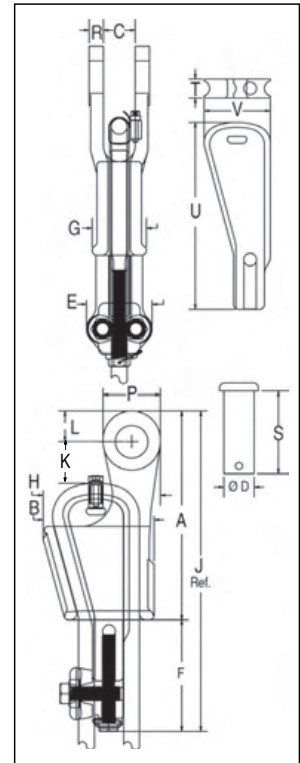

Scan this QR code with your smart device to view our Super Terminator video.



**\*\*Due to the unique construction of various ropes, Crosby cannot make a broad general statement that all current and future design of ropes, when properly assembled with the Super TERMINATOR, will achieve a minimum 80% termination efficiency. Contact wire rope manufacturer or Crosby engineering (918-834-4611) to determine efficiency rating for a specific rope**



## S-423T WEDGE SOCKETS Assembly includes Socket, Wedge, Pin, Wire Rope Clip, Tensioner, Bolts and Secondary Retention Wire.

Wire Rope Dia.		S-423T Assembly with Round Pin and Cotter Pin			S-423TB Assembly with Bolt, Nut and Cotter Pin			S-423TW** Wedge Kit		
(in)	(mm)	S-423T Stock No.	S-423T Weight Each		S-423TB Stock No.	S-423TB Weight Each		S-423TW Stock No.	S423TW Weight Each	
			(lb)	(kg)		(lb)	(kg)		(lb)	(kg)
5/8	14- 16	1035123	12.7	5.8	1035218	13.1	5.9	1034018	5.2	2.4
3/4	18-19	1035132	19.4	8.8	1035227	19.1	8.7	1034027	7.2	3.3
7/8	20-22	1035141	28.8	13.1	1035236	27.8	12.6	1034036	10.3	4.7
1	24-26	1035150	39.2	17.8	1035245	37.3	16.9	1034045	11.9	5.4
1-1/8	28	1035169	57.1	25.9	1035254	57.9	25.9	1034054	19.9	9.0
1-1/4	30-32	1035178	88.6	40.2	1035272	88.1	39.9	1034063	33.8	15.3

\*\*Kit contains Wedge, Wire Rope Clip and Bolts, Tensioner Bolt and Secondary Retention Wire.

Wire Rope Dia.		S-423T Stock No.	Dimensions (in)																
(in)	(mm)		A	B	C	D	E	F	G	H	J*	K	L	P	R	S	T	U	V
5/8	14-16	1035123	8.25	4.50	1.25	1.19	3.00	4.06	2.13	4.61	12.31	1.09	1.22	2.25	.56	3.25	.75	6.88	2.60
3/4	18-19	1035132	9.88	5.20	1.50	1.38	3.25	4.81	2.44	5.37	14.69	1.50	1.40	2.62	.66	3.63	.88	7.65	3.02
7/8	20-22	1035141	11.25	5.88	1.75	1.63	3.81	5.73	2.69	6.16	16.98	1.59	1.67	3.13	.75	4.31	1.00	9.47	3.47
1	24-26	1035150	12.81	6.56	2.00	2.00	3.81	5.73	2.94	7.05	18.54	1.44	2.01	3.75	.88	4.70	1.13	10.41	3.82
1-1/8	28	1035169	14.38	6.94	2.25	2.25	4.00	6.85	3.38	7.81	21.23	1.12	2.26	4.25	1.00	5.44	1.25	11.83	4.22
1-1/4	30-32	1035178	16.34	8.63	2.62	2.50	4.50	7.76	3.57	9.38	24.10	1.50	2.34	4.50	1.06	6.62	1.38	13.87	5.82

\* Nominal NOTE: For intermediate wire rope sizes, use next larger size socket. The S-423T Super TERMINATOR wedge is designed to be assembled only into the Crosby S-421T TERMINATOR socket body. IMPORTANT: The S-423TW for sizes 5/8" through 1-1/8" will fit respective size standard Crosby S-421 basket. The 1-1/4" S-423TW will only fit the Crosby S-421 1-1/4" basket marked with TERMINATOR.

## Button Spelter Sockets



**SB-427  
Button Spelter  
Socket**

- Available in six sizes from 1/2" to 1-1/2", (13mm - 38mm).
- Button Spelter terminations have a 100% efficiency rating, based on the catalog strength of the wire rope.
- Designed for use with mobile cranes. Can be used to terminate high performance, rotation resistant ropes, and standard 6 strand ropes.
- Easy to install assembly utilizes Crosby WIRELOCK® socketing compound.
- Sockets and buttons are re-usable.
- Replacement buttons and sockets are available.
- Locking feature available to prevent rotation of rope.
- Button contains cap with eye that can be attached to, and used to pull, rope during reeving process.
- Manufactured to the requirements of API-2C.

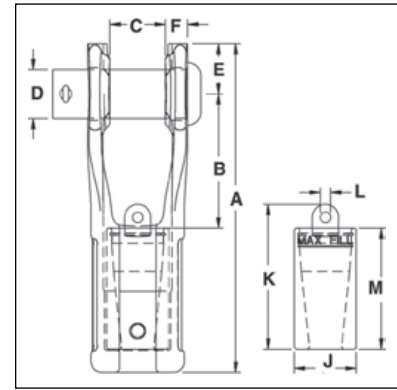

### SB-427 Button Spelter Sockets

Wire Rope Size		SB-427 Stock No.	Ultimate Load (t)	Weight Each (lb)	Button Only Stock No.	Dimensions (in)										Tolerance +/-
(in)	(mm)					A	B	C	D	E	F	J	K	L	M	C
1/2 - 5/8	13-16	1052005	27	6.1	1052309	7.94	3.23	1.28	1.19	1.22	.57	1.50	3.50	.25	2.93	.06
5/8 - 3/4	16-19	1052014	45	10.3	1052318	9.44	3.88	1.53	1.38	1.44	.66	1.75	4.28	.38	3.43	.06
3/4 - 7/8	19-22	1052023	57	17.1	1052327	10.81	4.41	1.78	1.62	1.69	.75	2.06	4.78	.38	3.96	.06
7/8 - 1	22-26	1052032	82	29.2	1052336	12.88	5.48	2.03	2.00	2.00	.89	2.44	5.62	.62	4.52	.09
1-1/8 - 1-1/4	28-32	1052041	136	46.0	1052345	14.90	5.68	2.53	2.25	2.50	1.11	2.94	7.08	.75	5.72	.09
1-3/8 - 1-1/2	35-38	1052050	161	78.0	1052354	18.06	7.17	3.03	2.75	2.75	1.24	3.62	8.08	.75	6.76	.09

### SB-427TB (Bolt, Nut and Cotter Pin)

Wire Rope Size		SB-427TB Stock No.	Ultimate Load (t)	Weight Each (lb)	Button Only Stock No.	Dimensions (in)										Tolerance +/-
(in)	(mm)					A	B	C	D	E	F	J	K	L	M	C
1/2 - 5/8	13-16	1052406	27	6.1	1052309	7.94	3.23	1.28	1.19	1.22	.57	1.50	3.50	.25	2.93	.06
5/8 - 3/4	16-19	1052415	45	10.3	1052318	9.44	3.88	1.53	1.38	1.44	.66	1.75	4.28	.38	3.43	.06
3/4 - 7/8	19-22	1052424	57	17.1	1052327	10.81	4.41	1.78	1.62	1.69	.75	2.06	4.78	.38	3.96	.06
7/8 - 1	22-26	1052433	82	29.2	1052336	12.88	5.48	2.03	2.00	2.00	.89	2.44	5.62	.62	4.52	.09
1-1/8 - 1-1/4	28-32	1052442	136	46.0	1052345	14.90	5.68	2.53	2.25	2.50	1.11	2.94	7.08	.75	5.72	.09
1-3/8 - 1-1/2	35-38	1052451	161	78.0	1052354	18.06	7.17	3.03	2.75	2.75	1.24	3.62	8.08	.75	6.76	.09

### Wirelock® Requirements

Wire Rope Size		WIRELOCK Required (cc)	WIRELOCK Stock No.	WIRELOCK Kit Size (cc)
(in)	(mm)			
1/2 - 5/8	13-16	35	1039602	100
5/8 - 3/4	16-19	60	1039602	100
3/4 - 7/8	19-22	100	1039602	100
7/8 - 1	22-26	140	1039602*	100
1-1/8 - 1-1/4	28-32	250	1039604	250
1-3/8 - 1-1/2	35-38	420	1039606	500

\* 2 kits required.



Scan this QR code with your smart device to view our Wedge and Button Sockets video.



# Mooring Spelter Sockets



**G-517  
Mooring  
Spelter Socket**

- Wide range of sizes available:
  - 1-1/4" through 4" Wireline
- "M-Line" socket terminations have a 100% efficiency rating, based on the catalog strength of the wire rope. Ratings are based on recommended use with 6 x 7, 6 x 19, or 6 x 37 IPS or XIP (EIP), XXIP (EEIP), RRL, FC, or IWRC wire rope. Strand constructed with minimal number of wires (e.g. 1 x 7) requires special consideration that socket basket length be five (5) times the strand diameter or fifty (50) times the wire diameter, whichever is the greater.
- Galvanized finish
- Designed for today's higher strength classes of wire rope.
- Design of bail allows for easy connection to shackles and other connecting links.
- Socket design utilizes features to keep cone from rotating.

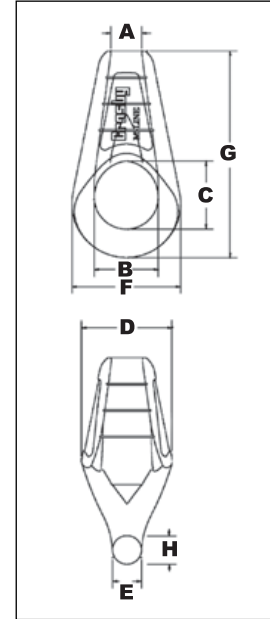

All Cast Mooring Sockets are Individually Magnetic Particle Inspected and Ultrasonic Inspected.

## G-517 "M-Line" Mooring Sockets

Wire Rope Size		Ultimate Load (t)	G-517 Stock No.	Weight Each (lb)	Dimensions (in)							
(in)	(mm)				A	B	C	D	E	F	G	H
1-1/4 - 1-3/8	32-35	113	1004943	17	1.63	3.09	3.63	4.45	1.44	5.13	10.89	1.53
1-1/2 - 1-5/8	38-41	136	1004961	30	1.95	3.69	4.32	5.43	1.60	6.31	13.00	1.81
1-3/4 - 1-7/8	44-48	181	1004989	43	2.23	4.16	4.53	6.30	1.84	7.22	14.11	2.09
2 - 2-1/8	50-54	227	1005002	57	2.50	4.75	5.26	7.02	2.09	8.25	16.02	2.24
2-1/4 - 2-3/8	57-60	277	1005020	76	2.78	5.25	5.78	7.72	2.31	9.16	17.90	2.62
2-1/2 - 2-5/8	64-67	363	1005048	106	3.05	5.88	6.71	8.53	2.69	10.13	19.89	2.66
2-3/4 - 2-7/8	70-73	454	1005066	138	3.33	6.50	7.13	9.35	3.00	11.09	21.63	2.98
3 - 3-1/8	76-79	544	1005084	193	3.50	7.25	7.74	10.30	3.25	12.31	23.50	3.24
3-1/4 - 3-3/8	82-86	635	1005105	229	3.81	7.62	8.80	10.94	3.50	13.13	25.75	3.43
3-1/2 - 3-5/8	88-92	735	1005123	279	4.15	8.00	9.06	11.72	3.69	13.96	27.70	4.12
3-3/4 - 4	95-102	907	1005141	384	4.39	8.75	10.50	12.91	3.69	15.88	30.13	4.46

## Open Spelter Sockets



**G-416 / S-416**

Open Grooved Sockets meet the performance requirements of Federal Specification RR-S-550, Type A, except for those provisions required of the contractor. For additional information, see page 452.

- Forged Steel Sockets through 1-1/2", cast alloy steel 1-5/8" through 4".
- Spelter socket terminations have an efficiency rating of 100%, based on the catalog strength of wire rope.
- Ratings are based on the recommended use with 6 x 7, 6 x 19 or 6 x 37, IPS or XIP (EIP), XXIP (EEIP), RRL, FC or IWRC wire rope.
- Strand constructed with minimal number of wires (e.g. 1 x 7) requires special consideration that socket basket length be five (5) times the strand diameter or fifty (50) times the wire diameter, whichever is the greater.

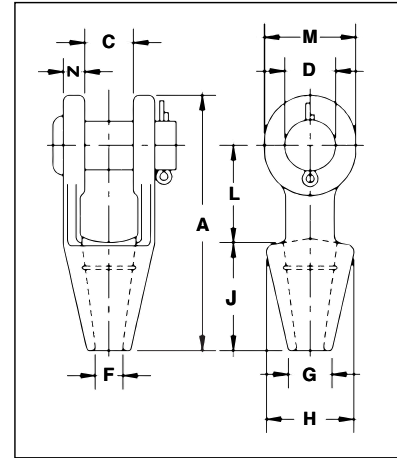

**NOTICE: All cast steel sockets 1-5/8" and larger are magnetic particle inspected and ultrasonic inspected. Proof testing available on special order.**

**Drawing illustrates one groove used on sockets 5/16" through 3/4". Sizes 7/8" through 1-1/2" use 2 grooves. Sizes 1-5/8" and larger use 3 grooves.**

### G-416 / S-416 Open Spelter Sockets

Rope Dia.		Structural Strand Dia. (in)	Ultimate Load (t)	Stock No.		Weight Each (lb)	Dimensions (in)										Tolerance +/-
(in)	(mm)			G-416 Galv.	S-416 S.C.		A	C	D	F	G	H	J	L	M	N	
5/16-3/8	8-10	—	12	1039637	1039646	1.30	4.84	.81	.81	.50	.81	1.69	2.25	1.75	1.50	.44	.06
7/16-1/2	11-13	—	20	1039655	1039664	2.25	5.56	1.00	1.00	.56	.94	1.88	2.50	2.00	1.88	.50	.06
9/16-5/8	14-16	1/2	27	1039673	1039682	3.60	6.75	1.25	1.19	.69	1.13	2.25	3.00	2.50	2.25	.56	.06
3/4	18	9/16-5/8	43	1039691	1039708	5.83	7.94	1.50	1.38	.81	1.25	2.62	3.50	3.00	2.62	.62	.06
7/8	20-22	11/16-3/4	55	1039717	1039726	9.65	9.25	1.75	1.63	.94	1.50	3.25	4.00	3.50	3.13	.80	.06
1	24-26	13/16-7/8	78	1039735	1039744	15.50	10.56	2.00	2.00	1.13	1.75	3.75	4.50	4.00	3.75	.88	.06
1-1/8	28-30	15/16-1	92	1039753	1039762	21.50	11.81	2.25	2.25	1.25	2.00	4.12	5.00	4.62	4.12	1.00	.12
1-1/4 - 1-3/8	32-35	1-1/16 - 1-1/8	136	1039771	1039780	31.00	13.19	2.50	2.50	1.50	2.25	4.75	5.50	5.00	4.75	1.13	.12
1-1/2	38	1-3/16 - 1-1/4	170	1039799	1039806	47.25	15.12	3.00	2.75	1.63	2.75	5.25	6.00	6.00	5.38	1.19	.12
* 1-5/8	* 40-42	1-5/16 - 1-3/8	188	1039815	1039824	55.00	16.25	3.00	3.00	1.75	3.00	5.50	6.50	6.00	5.75	1.31	.12
* 1-3/4 - 1-7/8	* 44-48	1-7/16 - 1-5/8	268	1039833	1039842	82.00	18.25	3.50	3.50	2.00	3.13	6.38	7.50	7.00	6.50	1.56	.12
* 2 - 2-1/8	* 50-54	1-11/16 - 1-3/4	291	1039851	1039860	129.00	21.50	4.00	3.75	2.25	3.75	7.38	8.50	9.00	7.00	1.81	.12
* 2-1/4 - 2-3/8	* 56-60	1-13/16 - 1-7/8	360	1039879	1039888	167.00	23.50	4.50	4.25	2.50	4.00	8.25	9.00	10.00	7.75	2.13	.12
* 2-1/2 - 2-5/8	* 64-67	1-15/16 - 2-1/8	424	1041633	1041642	252.00	25.50	5.00	4.75	2.88	4.50	9.25	9.75	10.75	8.50	2.38	.12
* 2-3/4 - 2-7/8	* 70-73	2-3/16 - 2-7/16	511	1041651	1041660	315.00	27.25	5.25	5.00	3.12	4.88	10.50	11.00	11.00	9.00	2.88	.25
* 3 - 3-1/8	* 75-80	2-1/2 - 2-5/8	563	1041679	1041688	380.00	29.00	5.75	5.25	3.38	5.25	11.12	12.00	11.25	9.50	3.00	.25
* 3-1/4 - 3-3/8	* 82-86	2-3/4 - 2-7/8	722	1041697	1041704	434.00	30.88	6.25	5.50	3.62	5.75	11.88	13.00	11.75	10.00	3.12	.25
* 3-1/2 - 3-5/8	* 88-92	3 - 3-1/8	779	1041713	1041722	563.00	33.25	6.75	6.00	3.88	6.50	12.38	14.00	12.50	10.75	3.25	.25
* 3-3/4 - 4	* 94-102	—	875	1041731	1041740	783.00	36.25	7.50	7.00	4.25	7.25	13.62	15.00	13.50	12.50	3.50	.25

\* Cast Alloy Steel. **NOTE: AVAILABLE WITH BOLT NUT AND COTTER. CONTACT CROSBY FOR MORE INFORMATION.**

# Closed Spelter Sockets



**G-417 / S-417**

Closed Grooved Sockets meet the performance requirements of Federal Specification RR-S-550, Type B, except for those provisions required of the contractor. For additional information, see page 452..

- Forged Steel Sockets through 1-1/2", cast alloy steel 1-5/8" through 4".
- Spelter socket terminations have an efficiency rating of 100%, based on the catalog strength of wire rope.
- Ratings are based on recommended use with 6 x 7, 6 x 19, or 6 x 37, IPS or XIP (EIP), XXIP (EEIP), RRL, FC, or IWRC wire rope.
- Strand constructed with minimal number of wires (e.g. 1 x 7) requires special consideration that socket basket length be five (5) times the strand diameter or fifty (50) times the wire diameter, whichever is the greater.

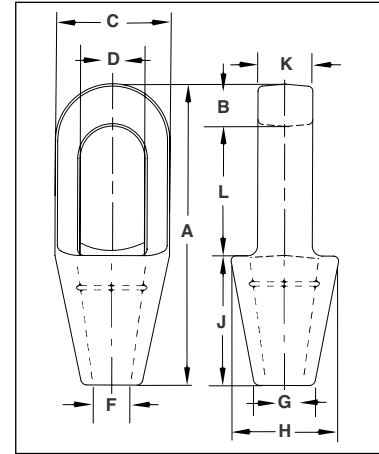

**NOTICE: All cast steel sockets 1-5/8" and larger are magnetic particle inspected and ultrasonic inspected. Proof testing available on special order.**

**Drawing illustrates one groove used on sockets 5/16" through 3/4". Sizes 7/8" through 1-1/2" use 2 grooves. Sizes 1-5/8" and larger use 3 grooves.**

## G-417 / S-417 Closed Spelter Sockets

Rope Dia.		Structural Strand Dia. (in)	Ultimate Load (t)	Stock No.		Weight Each (lb)	Dimensions (in)									
				G-417 Galv.	S-417 S.C.		A	B	C	D*	F	G	H	J	K	L
5/16 - 3/8	8-10	—	12.0	1039913	1039922	.75	4.94	.62	1.69	.97	.50	.81	1.69	2.25	.69	2.06
7/16 - 1/2	11-13	—	20.0	1039931	1039940	1.50	5.50	.69	2.00	1.16	.56	.94	2.00	2.50	.88	2.31
9/16 - 5/8	14-16	1/2	30.8	1039959	1039968	2.50	6.31	.81	2.63	1.41	.69	1.12	2.38	3.00	1.00	2.50
3/4	18	9/16 - 5/8	43.5	1039977	1039986	4.25	7.62	1.06	3.00	1.66	.88	1.25	2.75	3.50	1.25	3.06
7/8	20-22	11/16 - 3/4	65.3	1039995	1040000	7.25	8.75	1.25	3.63	1.94	1.00	1.50	3.25	4.00	1.50	3.50
1	24-26	13/16 - 7/8	81.6	1040019	1040028	10.50	9.91	1.41	4.13	2.30	1.13	1.75	3.75	4.50	1.75	4.00
1-1/8	28-30	15/16 - 1	100	1040037	1040046	14.25	11.00	1.50	4.50	2.56	1.25	2.00	4.13	5.00	2.00	4.50
1-1/4 - 1-3/8	32-35	1-1/16 - 1-1/8	136	1040055	1040064	19.75	12.12	1.63	5.00	2.81	1.50	2.25	4.75	5.50	2.25	5.00
1-1/2	38	1-3/16 - 1-1/4	170	1040073	1040082	29.20	13.94	1.94	5.38	3.19	1.63	2.75	5.25	6.00	2.50	6.00
† 1-5/8	† 40-42	1-5/16 - 1-3/8	188	1040091	1040108	36.00	15.13	2.13	5.75	3.25	1.75	3.00	5.50	6.50	2.75	6.50
† 1-3/4 - 1-7/8	† 44-48	1-7/16 - 1-5/8	268	1040117	1040126	57.25	17.25	2.19	6.75	3.75	2.00	3.13	6.38	7.50	3.00	7.56
† 2 - 2-1/8	† 50-54	1-11/16 - 1-3/4	309	1040135	1040144	79.00	19.87	2.44	7.63	4.38	2.25	3.75	7.38	8.50	3.25	8.81
† 2-1/4 - 2-3/8	† 56-60	1-13/16 - 1-7/8	360	1040153	1040162	105.00	21.50	2.75	8.50	5.00	2.63	4.13	8.25	9.00	3.63	9.75
† 2-1/2 - 2-5/8	† 64-67	1-15/16 - 2-1/8	424	1041759	1041768	140.00	23.50	3.12	9.50	5.50	2.88	4.50	9.25	9.75	4.00	10.62
† 2-3/4 - 2-7/8	† 70-73	2-3/16 - 2-7/16	549	1041777	1041786	220.00	25.38	3.12	10.75	6.25	3.12	4.88	10.19	11.00	4.88	11.25
† 3 - 3-1/8	† 75-80	2-1/2 - 2-5/8	656	1041795	1041802	276.00	27.12	3.37	11.50	6.75	3.38	5.25	11.50	12.00	5.25	11.75
† 3-1/4 - 3-3/8	† 82-86	2-3/4 - 2-7/8	750	1041811	1041820	313.00	29.25	4.00	12.25	7.25	3.62	5.75	12.25	13.00	5.75	12.25
† 3-1/2 - 3-5/8	† 88-92	3 - 3-1/8	820	1041839	1041848	400.00	31.00	4.00	13.00	7.75	3.88	6.31	13.00	14.00	6.25	13.00
† 3-3/4 - 4	† 94 - 102	—	1005	1041857	1041866	542.00	33.25	4.25	14.25	8.50	4.25	7.25	14.25	15.00	7.00	14.00

\* Diameter of pin must not exceed pin used on companion 416 socket. Reference adjacent page "D" dimension. † Cast Alloy Steel.





**S-505 Swaging Sleeve**

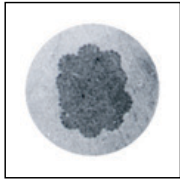

Cross Section of Swaged Sleeve



Scan this QR code with your smart device to view our QUIC-PASS Swaging System video.

- For Flemish eye wire rope splicing.
- Designed for low temperature toughness.
- Resists cracking when swaged (equals or exceeds stainless steel sleeves).
- Special processed low carbon steel.
- “COLD TUFF”<sup>®</sup> for better swageability.
- Can be stamped for identification after swaging without concern for fractures when following these directions.
  - Use round corner stamps to a maximum depth of 0.015 in. (1/64). The area for stamping should be on the side of the sleeve in the plane of the sling eye, and no less than 0.250 in. (1/4) from either end of the sleeve.
- Standard Steel Sleeve terminations have efficiency ratings as follows based on the catalog strength of wire rope.
- Do not use on wire rope size other than size shown.

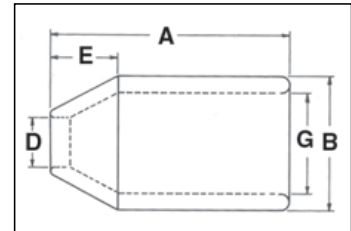

NOTE: See Page 45 for dimensional information.

S-505 Termination Efficiency		
Size (in)	Type of Wire Rope *	
	IWRC	FC
1/4 - 1	96%	93%
1-1/8 - 2	92%	89%
2-1/4 and Larger	90%	87%



**\*\* NOTE:** S-505 Standard Sleeves are recommended for use with 6 x 19 or 6 x 37, IPS or XIP (EIP), XXIP (EEIP), RRL, FC or IWRC wire rope. Before using any National Swage fitting with any other type la , construction or grade of wire rope, it is recommended that the termination be destructive and documented to prove the adequacy of the assembly to be manufactured.

## National QUIC-PASS<sup>®</sup> Swaging System

*“The Next Generation in Swaging Systems”*

### QUIC-PASS<sup>®</sup>

The **QUIC-PASS<sup>®</sup>** swaging system allows “Flemish style” wire rope terminations to be swaged in only two passes.

This is accomplished while maintaining currently published efficiency ratings and utilizing National Swage S-505 Standard “COLD TUFF”<sup>®</sup> Steel Sleeves.

- Allows the swaging process to be completed in just two passes. Resulting in a 50-75% reduction in the number of passes required with conventional swaging systems.
- Allows the dies to close completely with each pass, resulting in...
  - An increase in overall swaging process efficiencies (the job can be performed quicker).
  - A reduction in the complexity of swaging (the concern for excess flashing between dies has been eliminated).
  - A reduction in training time needed for operators (more user friendly).
- The finished sleeve has a “Hex” appearance that provides a QUIC-CHEC<sup>®</sup> look to determine if the termination has been swaged and provides a flat su face that allows for ease of I.D. stamping on the finished sleeve.

For additional swaging information, please refer to the Wire Rope End Terminations User’s Manual.

# National Steel Swaging Sleeves

## S-505 COLD TUFF® Standard Steel Sleeves

S-505 Standard Steel Sleeve Specifications												Swager / Die Data		
S-505 Stock No.	Rope Size		Weight Per 100 (lb)	Pkg. Qty.	Before Swage Dimensions (in)					Maximum After Swage Dimensions (in)		Standard Round Dies		QUIC-PASS Dies
	(in)	(mm)			A	B	D	E	G	Standard Die	QUIC-PASS Die	Die Description	Standard Die Stock No.	QUIC-PASS Die Stock No.
1041063	1/4	6-7	5	250	1.00	.66	.31	.28	.47	.57	.565	1/4 Taper	1197528	1923530
1041090	5/16	8	14	200	1.50	.91	.44	.44	.62	.75	.769	3/8 Taper	1192364	1923551
1041107	3/8	9-10	14	100	1.50	.91	.47	.39	.66	.75	.769	3/8 Taper	1192364	1923551
1041125	7/16	11	33	50	2.00	1.22	.55	.65	.85	1.01	1.016	1/2 Taper	1192408	1923572
1041143	1/2	13	29	50	2.00	1.22	.63	.56	.91	1.01	1.016	1/2 Taper	1192408	1923572
1041161	9/16	14	64	25	2.75	1.47	.69	.63	1.03	1.24	1.247	5/8 Taper	1192444	1923593
1041189	5/8	16	56	25	2.75	1.47	.75	.63	1.09	1.24	1.247	5/8 Taper	1192444	1923593
1041205	3/4	18-19	88	20	3.19	1.72	.91	.84	1.28	1.46	1.475	3/4 Taper	1192462	1923614
1041223	7/8	22	131	10	3.56	2.03	1.03	1.00	1.53	1.68	1.738	7/8 Taper	1192480	1923635
1041241	1	25-26	195	10	4.00	2.28	1.16	1.13	1.72	1.93	1.955	1 Taper	1192505	1923656
1041269	1-1/8	28-29	260	Bulk	4.81	2.50	1.28	1.25	1.94	2.13	2.170	1-1/8 Open 1st Stage 2nd Stage	1192523 1192541	1923677
1041287	1-1/4	31-32	355	Bulk	5.19	2.78	1.44	1.41	2.16	2.32	2.405	1-1/4 Open 1st Stage 2nd Stage	1192621 1192587	1923698
1041303	1-3/8	34-35	423	Bulk	5.81	3.00	1.56	1.56	2.38	2.52	2.610	1-3/8 Open 1st Stage 2nd Stage	1192667 1192621	1923717
1041321	1-1/2	37-38	499	Bulk	6.25	3.25	1.69	1.69	2.63	2.71	2.835	1-1/2 Open 1st Stage 2nd Stage	1192649 1192667	1923736

Note: Fittings designed only to be used on exact sizes listed.

## S-505 COLD TUFF® Standard Steel Sleeves

S-505 Standard Steel Sleeve Specifications												Swager / Die Data				
S-505 Stock No.	Rope Size		Weight Per 100 (lb)	Pkg. Qty.	Before Swage Dimensions (in)					Maximum After Swage Dimensions (in)	Die Description	Stock No.				
	(in)	(mm)			A	B	D	E	G			500 Tons 1000 Tons 1500 Tons 5x7	Front Load		Side Load	
											1500 Ton 6x12	3000 Ton 6x12	1500 Ton 6x12	3000 Ton 6x12		
1041349	1-3/4	44-45	805	Bulk	7.25	3.84	1.94	1.97	3.13	3.10	1192685 1192701	—	—	—	—	
1041367	2	50-52	1132	Bulk	8.50	4.38	2.25	2.25	3.63	3.56	1192729 1192747	—	—	—	—	
1041385	2-1/4	56-57	1936	Bulk	9.56	5.03	2.50	2.53	4.03	4.12	1192765 1192783	1191089 1191043	1191089 1191043	—	1195085 1195067	
1041401	2-1/2	62-64	2352	Bulk	10.50	5.50	2.75	2.81	4.50	4.50	—	1191061 1191089	1191061 1191089	1195370 1195469	1195076 1195085	
1041429	2-3/4	68-70	2800	Bulk	11.50	5.75	3.00	3.09	4.75	4.70	—	1191034 1191052	1191034 1191052	1195389 1195478	1195094 1195101	
1041447	3	75-76	2940	Bulk	12.00	6.00	3.25	3.38	5.00	4.96	—	1193201 1193229	1193201 1193229	1195398 1195487	1195110 1195129	
1041483	3-1/2	87-89	4640	Bulk	14.00	7.00	3.88	3.94	5.84	5.77	—	1193247 1193265	1193247 1193265	—	1195138 1195147	
1041492	3-3/4	93-95	5500	Bulk	15.00	7.50	4.06	4.25	6.31	6.23	—	—	1191114 1191132	—	1195263 1195272	
1041508	4	100-105	6800	Bulk	16.00	8.13	4.38	4.50	6.81	6.69	—	—	1191150 1191178	—	1195156 1195165	
1041526	4-1/2	112-114	10000	Bulk	18.00	9.13	4.88	5.06	7.66	7.45	—	—	1191187 1191203	—	1195174 1195183	

Note: Fittings designed only to be used on exact sizes listed.

Intermediate Metric Die Chart

Sleeve and Swaging Die Requirements for Intermediate Sizes of Metric Wire Rope							
S-505 Stock No.	S-505 Sleeve Size	Metric Wire Rope Size (mm)	Standard Round Dies				Maximum After Swage Dimension (in)
			1st Stage Die		2nd Stage Die		
			Die No.	Die Description	Die No.	Die Description	
1041143	1/2	12	1190881	5 x 7 Double Cavity	—		.990
1041223	7/8	20	1190901	5 x 7 Double Cavity	—		1.620
1041241	1	24	1190921	5 x 7 Double Cavity	—		1.880
1041321	1-1/2	36	1192649	5 x 7	1190941	5 x 7	2.630
1041349	1-3/4	40	1192685	5 x 7	1190961	5 x 7	2.950
1041367	2	48	1192729	5 x 7	1190971	5 x 7	3.460
1041401	2-1/2	60	1192809	5 x 7	1190981	5 x 7	4.370
1041401	2-1/2	60	1191061	6 x 12	1190991	6 x 12	4.370
1041487	3	72	1193201	6 x 12	1191001	6 x 12	4.810
1041483	3-1/2	80	1193247	6 x 12	1191101	6 x 12	5.450
1041483	3-1/2	84	1193247	6 x 12	1191121	6 x 12	5.550

QUIC-PASS® system not available for these metric rope sizes. Note: Fittings designed only to be used on exact sizes listed.



# Open Swage Sockets



**S-501  
Open Swage  
Sockets**

- Forged from special bar quality carbon steel, suitable for cold forming.
- Swage Socket terminations have an efficiency rating of 100% based on the catalog strength of wire rope.
- Hardness controlled by spheroidize annealing.
- Stamp for identification after swaging without concern for fractures (as per directions in Wire Rope End Terminations User's Manual).
- Swage sockets incorporate a reduced machined area of the shank which is equivalent to the proper "After Swage" dimension. Before swaging, this provides for an obvious visual difference in the shank diameter. After swaging, a uniform shank diameter is created allowing for a QUIC-CHECK® and permanent visual inspection opportunity.
- Designed to quickly determine whether the socket has been through the swaging operation and assist in field inspections, it does not eliminate the need to perform standard production inspections which include gauging for the proper "After Swage" dimensions or proof loading.

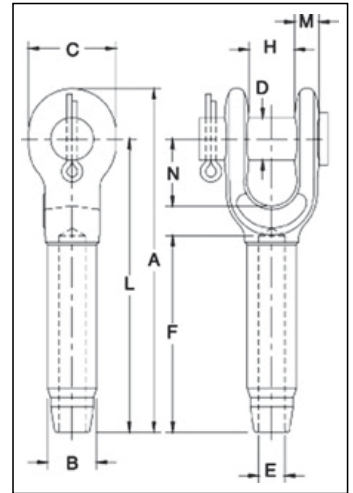

**NOTE:** S-501 Swage Sockets are recommended for use with 6 x 19 or 6 x 37, IPS or XIP (EIP), XXIP (EEIP), RRL, FC or IWRC wire rope. Before using any National Swage fitting with any other type la, construction or grade of wire rope, it is recommended that the termination be destructive tested and documented to prove the adequacy of the assembly to be manufactured. In accordance with ASME B30.9, all slings terminated with swage sockets shall be proof loaded.\*



## S-501 Open Swage Sockets

S-501 and S-501B Open Socket Specifications															Swager / Die Data							
S-501 Stock No.	S-501B Stock No. †	Rope Size		Wt. Each (lb)	Ultimate Load** (t)	Before Swage Dimensions (in)										Tolerance +/-	Max. After Swage Dim. (in)	Die Description	Stock No.			
		(in)	(mm)			A	B	C	D	E	F	H	L	M	N				H	500 Ton 5 x 7	1500 Ton 6 x 12	1500 Ton 6 x 12
1039021	1054001	1/4	6	.52	5.4	4.78	.50	1.38	.69	.27	2.19	.69	4.00	.38	1.47	.06	.46	1/4 Socket	1192845	-	-	-
1039049	1054010	5/16	8	1.12	11.8	6.30	.78	1.62	.81	.34	3.25	.80	5.34	.48	1.67	.06	.71	5/16-3/8 Socket	1192863	-	-	-
1039067	1054029	3/8	9-10	1.30	13.6	6.30	.78	1.62	.81	.41	3.25	.80	5.34	.48	1.67	.06	.71	5/16-3/8 Socket	1192863	-	-	-
1039085	1054038	7/16	11-12	2.08	18.1	7.82	1.01	2.00	1.00	.49	4.31	1.00	6.69	.56	1.96	.06	.91	7/16-1/2 Socket	1192881	-	-	-
1039101	1054047	1/2	13	2.08	21.3	7.82	1.01	2.00	1.00	.55	4.31	1.00	6.69	.56	1.96	.06	.91	7/16-1/2 Socket	1192881	-	-	-
1039129	1054056	9/16	14	4.67	31.8	9.54	1.27	2.38	1.19	.61	5.38	1.25	8.13	.68	2.21	.06	1.16	9/16-5/8 Socket	1192907	-	-	-
1039147	1054065	5/8	16	4.51	34.9	9.54	1.27	2.38	1.19	.68	5.38	1.25	8.13	.68	2.21	.06	1.16	9/16-5/8 Socket	1192907	-	-	-
1039165	1054074	3/4	18-20	7.97	43.5	11.61	1.56	2.75	1.38	.80	6.44	1.50	10.00	.80	2.69	.06	1.42	3/4 Socket	1192925	-	-	-
1039183	1054083	7/8	22	11.52	51.5	13.37	1.72	3.13	1.63	.94	7.50	1.75	11.63	.94	3.20	.07	1.55	7/8 Socket	1192943	-	-	-
1039209	1054092	1	24-26	17.80	71.4	15.47	2.00	3.69	2.00	1.07	8.63	2.00	13.38	1.07	3.68	.08	1.80	1 Socket	1192961	-	-	-
1039227	1054104	1-1/8	28	25.25	83.3	17.35	2.25	4.12	2.25	1.19	9.63	2.25	15.00	1.19	4.18	.10	2.05	1-1/8 Socket	1192989	-	-	-
1039245	1054113	1-1/4	32	35.56	109	19.20	2.53	4.59	2.50	1.34	10.69	2.50	16.50	1.27	4.68	.10	2.30	1-1/4 Socket	1193005	-	-	-
1039263	1054122	1-3/8	34-36	43.75	136	21.10	2.81	5.25	2.50	1.46	11.88	2.41	18.13	1.46	5.25	.10	2.56	1-3/8 Socket	1193023	-	-	-
1039281	1054131	1-1/2	38-40	58.50	181	23.17	3.08	5.50	2.75	1.59	12.81	3.00	19.75	1.70	5.70	.10	2.81	1-1/2 Socket	1193041	1191267	1195355	1195192
1039307	1054140	1-3/4	44	88.75	228	26.70	3.40	6.25	3.50	1.87	15.06	3.50	23.00	2.11	6.67	.10	3.06	1-3/4 Socket	1193069	1191276	1195367	1195209
1042767	1054159	2	48-52	146.2	272	31.15	3.94	7.80	3.75	2.12	17.06	4.00	26.75	1.81	8.19	.10	3.56	2 Socket	1193087	1191294	1195379	1195218

\*Maximum Proof Load shall not exceed 50% of XXIP rope catalog breaking strength. \*\* The Ultimate Loads of 3/4" through 1 1/4" sizes have been increased to meet the requirements for 8 strand 2160 Grade pendants. † Assembly with bolt, nut and cotter pin. Note: Fittings designed only to be used on exact sizes listed.



**S-502  
Closed Swage  
Sockets**

- Forged from special bar quality carbon steel, suitable for cold forming.
- Swage Socket terminations have an efficiency rating of 100% based on the catalog strength of wire rope.
- Hardness controlled by spheroidize annealing.
- Stamp for identification after swaging without concern for fractures (as per directions in Wire Rope End Terminations User's Manual).
- Swage sockets incorporate a reduced machined area of the shank which is equivalent to the proper "After Swage" dimension. Before swaging, this provides for an obvious visual difference in the shank diameter. After swaging, a uniform shank diameter is created allowing for a **QUIC-CHECK®** and permanent visual inspection opportunity.
- Designed to quickly determine whether the socket has been through the swaging operation and assist in field inspections, it does not eliminate the need to perform standard production inspections which include gauging for the proper "After Swage" dimensions or proof loading.

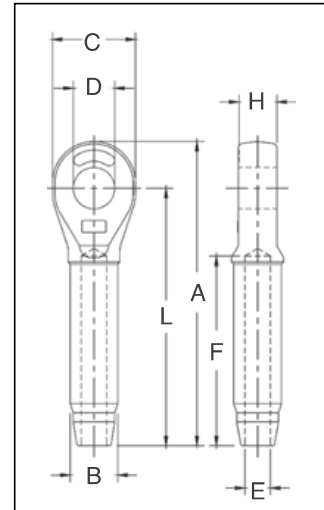

**NOTE:** S-502 Swage Sockets are recommended for use with 6 x 19 or 6 x 37, IPS or XIP (EIP), XXIP (EEIP), RRL, FC or IWRC wire rope. Before using any National Swage fitting with any other type la , construction or grade of wire rope, it is recommended that the termination be destructive tested and documented to prove the adequacy of the assembly to be manufactured. In accordance with ASME B30.9, all slings terminated with swage sockets shall be proof loaded.\*



## S-502 Closed Swage Sockets

S-502 Closed Socket Specifications													Swager / Die Data					
S-502 Stock No.	Rope Size		Wt. Each (lb)	Ultimate Load** (t)	Before Swage Dimensions (in)							Max. After Swage Dim. (in)	Die Description	Stock No.		Side Load		
	(in)	(mm)			A	B	C	D	E	F	H			L	500 1000 1500 Ton 5 x 7	1500 3000 Ton 6 x 12	1500 Ton 6 x 12	3000 Ton 6 x 12
1039325	1/4	6	.33	5.4	4.28	.50	1.38	.76	.27	2.19	.50	3.50	.46	1/4 Socket	1192845	-	-	-
1039343	5/16	8	.75	11.8	5.42	.77	1.62	.88	.34	3.25	.68	4.50	.71	5/16-3/8 Socket	1192863	-	-	-
1039361	3/8	9-10	.72	13.6	5.42	.78	1.62	.88	.41	3.25	.68	4.50	.71	5/16-3/8 Socket	1192863	-	-	-
1039389	7/16	11-12	1.42	18.1	6.88	1.01	2.00	1.07	.49	4.31	.87	5.75	.91	7/16-1/2 Socket	1192881	-	-	-
1039405	1/2	13	1.42	21.3	6.88	1.01	2.00	1.07	.55	4.31	.87	5.75	.91	7/16-1/2 Socket	1192881	-	-	-
1039423	9/16	14	2.92	31.8	8.59	1.27	2.38	1.28	.61	5.38	1.14	7.25	1.16	9/16-5/8 Socket	1192907	-	-	-
1039441	5/8	16	2.85	34.9	8.59	1.27	2.38	1.28	.68	5.38	1.14	7.25	1.16	9/16-5/8 Socket	1192907	-	-	-
1039469	3/4	18-20	5.00	43.5	10.25	1.56	2.88	1.49	.80	6.44	1.33	8.63	1.42	3/4 Socket	1192925	-	-	-
1039487	7/8	22	6.80	51.5	11.87	1.72	3.12	1.73	.94	7.50	1.53	10.09	1.55	7/8 Socket	1192943	-	-	-
1039502	1	24-26	10.40	71.4	13.56	2.00	3.62	2.11	1.07	8.63	1.78	11.50	1.80	1 Socket	1192961	-	-	-
1039520	1-1/8	28	14.82	83.3	15.03	2.25	4.00	2.37	1.19	9.75	2.03	12.75	2.05	1-1/8 Socket	1192989	-	-	-
1039548	1-1/4	32	21.57	109	16.94	2.53	4.50	2.62	1.34	10.81	2.25	14.38	2.30	1-1/4 Socket	1193005	-	-	-
1039566	1-3/8	34-36	28.54	136	18.59	2.81	5.00	2.62	1.46	11.88	2.29	15.75	2.56	1-3/8 Socket	1193023	-	-	-
1039584	1-1/2	38-40	38.06	181	20.13	3.08	5.38	2.87	1.59	12.81	2.56	17.00	2.81	1-1/2 Socket	1193041	1191267	1195355	1195192
1039600	1-3/4	44	51.00	228	23.56	3.40	6.25	3.63	1.87	15.06	3.08	20.00	3.06	1-3/4 Socket	1193069	1191276	1195367	1195209
1042589	2	48-52	89.25	272	27.13	3.94	7.25	3.88	2.12	17.06	3.31	23.00	3.56	2 Socket	1193087	1191294	1195379	1195218

\* Maximum Proof Load shall not exceed 50% of XXIP rope catalog breaking strength. \*\*The Ultimate Loads of 3/4" through 1 1/4" sizes have been increased to meet the requirements for 8 strand 2160 Grade pendants. Note: Fittings designed only to be used on exact sizes listed.

# National Swage Buttons



**S-409 Swage Buttons**

- Swage Button terminations have an efficiency rating of 98% based on the catalog strength of wire rope.
- Special processed, low carbon steel.
- COLD TUFF® for better swageability.
- Stamp for identification after swaging without concern for fractures (as per directions in the Wire Rope End Terminations User's Manual).

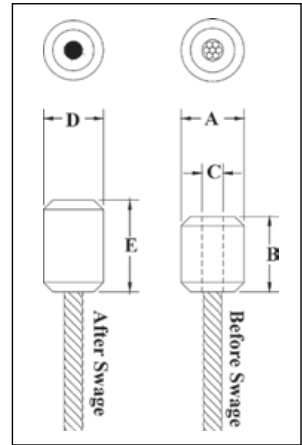

Wire Rope End Fittings



**NOTE:** S-409 Buttons are recommended for use with 6 x 19 or 6 x 37, IPS or XIP (EIP), RRL, FC or IWRC wire rope. Before using any National Swage fitting with any other type la , construction or grade of wire rope, it is recommended that the termination be destructive tested and documented to prove the adequacy of the assembly to be manufactured.

## S-409 COLD TUFF® Buttons

S-409 Steel Swage Button Specifications										Swager / Die Data	
S-409 Stock No.	Size No.	Rope Size		Weight Per 100 (lb)	Before Swage Dimensions (in)			After Swage Dimensions (in)		Die Description	Stock No. 500 Tons 1000 Tons 1500 Tons 5 x 7
		(in)	(mm)		A	B	C	D Maximum After Swage Dimensions	E Length*		
1040171	1 SB	1/8	3	2	.42	.50	.14	.40	.61	1/8 - 1/4 Button	1191621
1040215	3 SB	3/16	5	4	.56	.70	.20	.52	.84	1/4 1st Stage	1197528
1040251	5 SB	1/4	6-7	8	.68	1.06	.31	.58	1.41	1/8 - 1/4 Button	1191621
1040297	7 SB	5/16	8	16	.88	1.13	.36	.77	1.33	3/8 1st Stage	1192364
1040313	8 SB	3/8	9-10	15	.88	1.48	.42	.77	1.69	3/8 1st stage	1192364
1040331	9 SB	7/16	11	30	1.13	1.63	.48	1.03	1.94	1/2 1st Stage	1192408
1040359	10 SB	1/2	13	50	1.31	1.89	.55	1.16	2.17	5/8 Socket	1192907
1040377	11 SB	9/16	14	70	1.44	2.02	.61	1.29	2.41	9/16 - 5/8 Button	1191665
1040395	12 SB	5/8	16	100	1.56	2.42	.67	1.42	2.89	3/4 Socket	1192925
1040411	13 SB	3/4	18-20	131	1.68	2.74	.80	1.55	3.25	3/4 1st Stage	1192462
1040439	14 SB	7/8	22	220	2.00	3.27	.94	1.80	3.86	7/8 1st Stage	1192480
1040457	15 SB	1	25-26	310	2.25	3.67	1.06	2.05	4.36	1 1st Stage	1192505
1040475	16 SB	1-1/8	28-29	450	2.56	4.05	1.19	2.30	4.81	1-1/8 1st Stage	1192523
1040493	17 SB	1-1/4	31-32	650	2.81	4.57	1.33	2.56	5.42	1-3/8 Socket	1193023

\* NOTE: Length is measured from outside end of termination. Fittings designed only to be used on exact sizes listed.



# National Swage Duplex Sleeves



**S-506  
Duplex Sleeves**

- For turnback wire rope splicing.
- Special processed low carbon steel.
- Turnback terminations have efficiency ratings of 94% based on the catalog strength of wire rope.
- Designed for lower temperature toughness.
- Resists cracking when swaged (equals or exceeds stainless steel sleeves).
- COLD TUFF® for better swageability.
- Stamp for identification after swaging without concern for fractures (as per directions in the Wire Rope End Termination User's Manual).

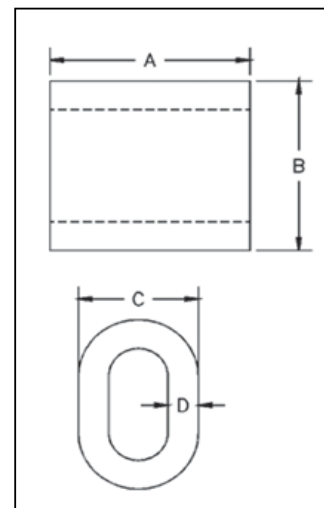

**NOTE:** S-506 Sleeves are recommended for use with 6 x 19 or 6 x 37, IPS or XIP (EIP), RRL, FC or IWRC wire rope. Before using any National Swage fitting with any other type la , construction or grade of wire rope, it is recommended that the termination be destructive tested and documented to prove the adequacy of the assembly to be manufactured.

## S-506 COLD TUFF® Duplex Non-Tapered Sleeves

S-506 Steel Duplex Non-Tapered Sleeve Specifications										Swager / Die Data		
S-506 Stock No.	Rope Size		Weight Per 100 (lb)	Pkg. Qty.	Before Swage Dimensions (in)				Max. After Swage Dimensions (in)	Die Description	Stock No. 500 Tons 1000 Tons 1500 Tons 5 x 7	
	(in)	(mm)			A	B	C	D				
	1039334	5/16			8	17	200	1.25				1.06
1039352	3/8	9-10	13	100	1.25	1.12	.81	.14	.77	3/8 1st Stage	1192364	
1039370	7/16	11	31	50	1.63	1.41	1.02	.19	1.03	1/2 1st Stage	1192408	
1039398	1/2	13	27	50	1.63	1.44	1.02	.16	1.03	1/2 1st Stage	1192408	
1039414	9/16	14	63	25	2.25	1.72	1.23	.23	1.29	5/8 1st Stage	1192444	
1039432	5/8	16	54	25	2.25	1.84	1.28	.20	1.29	5/8 1st Stage	1192444	
1039450	3/4	18-20	91	10	2.63	2.16	1.52	.23	1.55	3/4 1st Stage	1192462	
1039478	7/8	22	126	10	2.88	2.50	1.75	.27	1.80	7/8 1st Stage	1192480	
1039496	1	25-26	187	10	3.06	2.84	2.00	.33	2.05	1 1st Stage	1192505	
1039539	1-1/4	30-32	384	Bulk	4.06	3.50	2.50	.38	2.56	1-3/8 Socket	1193023	

Note: Fittings designed only to be used on exact sizes listed.

# Shank Hooks For Swaging



**S-319SWG  
Shank Hook**

- Wide range of sizes available:
  - Working Load Limit: 0.4-14 Ton
  - Wire Rope sizes: 3/16" through 1-1/8".
- Swage shank hook terminations have an efficiency rating of 95% based on the catalog strength of wire rope.
- Quenched and Tempered. Heat treat process allows for ease of swaging.
- Forged Carbon Steel.
- Design Factor of 5:1.
- Black Oxide finish on body (Shank is uncoated)
- Utilizes standard Crosby 319N shank hooks with interlocking hook tip. Each hook has a pre-drilled cam which can be equipped with a latch.
- Utilizes standard National Swage swaging dies.
- All hooks incorporate Crosby's patented **QUIC-CHECK®** markings (Angle Indicators and Throat Deformation Indicators). See page 113 for detailed information.

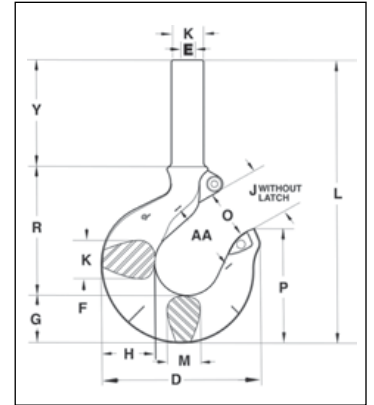

**NOTE:** For use with 6 X 19 or 6 X 37, IPS or XIP (EIP), XXIP (EEIP), RRL, FC, or IWRC wire rope.

Before using any Crosby fitting with any other type *la*, construction or grade of wire rope, it is recommended that the termination be destructively tested and documented to prove the adequacy of the assembly to be manufactured. Refer to swage socket or swage button instructions in the National Swage Swaging Products and Procedures Brochure for proper swaging techniques.

## S-319SWG Shank Hooks for Swaging

Wire Rope Size		Hook ID Code†	Working Load Limit (Tons)*	S-319SWG Stock No.	Weight Each (lb)	Required Swaging Die		Maximum After Swage Diameter (in)
(in)	(mm)					Die Description	Die Stock No.	
3/16	5	DC	0.4	1053002	.55	1/8" Button	1191621	.40
1/4	6-7	FC	0.7	1053011	.77	1/4" Socket	1192845	.46
5/16	8	GC	1.1	1053020	1.26	1/4" Button	1191621	.58
5/16	8	HC	1.1	1053039	1.83	3/8" Socket	1192863	.71
3/8	9-10	HC	1.6	1053048	1.80	3/8" Socket	1192863	.71
7/16	11	IC	2.1	1053057	3.63	1/2" Socket	1192881	.91
1/2	12-13	IC	2.8	1053066	3.58	1/2" Socket	1192881	.91
9/16	14-15	JC	3.5	1053075	7.37	5/8" Socket	1192907	1.16
5/8	16	JC	4.3	1053084	7.30	5/8" Socket	1192907	1.16
3/4	18	KC	6.2	1053093	12.73	3/4" Socket	1192925	1.42
7/8	20-22	LC	8.3	1053100	17.58	7/8" Socket	1192949	1.55
1	24-26	NC	11.0	1053119	31.46	1" Socket	1192961	1.80
1-1/8	28-30	OC **	14.0	1053128	53.73	1-1/8" Socket	1192989	2.05

\* Minimum Ultimate Load is 5 times the Working Load Limit. \*\* ID Code "O" is original 319 style hook. † See tables on pages 123 - 125 for correct latch per Hook ID Code.

Wire Rope Size		S-319SWG Stock No.	Dimensions (in)														
(in)	(mm)		B	D	E	F	G	H	J	K	L	M	O	P	R	Y	AA**
3/16	5	1053002	.44	2.86	.20	.63	.73	.81	.93	.63	5.18	.63	.93	1.96	2.39	2.00	1.50
1/4	6-7	1053011	.50	3.15	.27	.69	.84	.94	.97	.71	5.72	.71	.97	2.22	2.63	2.25	2.00
5/16	8	1053020	.65	3.59	.34	.75	1.00	1.16	1.06	.88	6.39	.88	1.06	2.44	2.80	2.50	2.00
5/16	8	1053039	.77	3.99	.34	.81	1.14	1.31	1.19	.94	7.18	.94	1.16	2.78	3.21	2.75	2.00
3/8	9-10	1053048	.77	3.99	.41	.81	1.14	1.31	1.19	.94	7.18	.94	1.16	2.78	3.21	2.75	2.00
7/16	11	1053057	.98	4.84	.48	1.00	1.44	1.63	1.50	1.31	8.70	1.13	1.41	3.47	3.92	3.25	2.50
1/2	12-13	1053066	.98	4.84	.55	1.00	1.44	1.63	1.50	1.31	8.70	1.13	1.41	3.47	3.92	3.25	2.50
9/16	14-15	1053075	1.25	6.27	.61	1.25	1.82	2.06	1.78	1.66	10.51	1.44	1.69	4.59	4.86	3.75	3.00
5/8	16	1053084	1.25	6.27	.67	1.25	1.82	2.06	1.78	1.66	10.51	1.44	1.69	4.59	4.86	3.75	3.00
3/4	18	1053093	1.55	7.54	.80	1.50	2.26	2.63	2.41	1.88	12.63	1.63	2.22	5.25	6.00	4.25	4.00
7/8	20-22	1053100	1.70	8.33	.94	1.63	2.60	2.94	2.62	2.19	13.60	1.94	2.41	5.69	6.51	4.38	4.00
1	24-26	1053119	1.98	10.38	1.06	2.13	3.01	3.50	3.41	2.69	16.80	2.38	3.19	6.88	8.30	5.38	4.00
1-1/8	28-30	1053128	2.25	13.63	1.19	2.50	3.62	4.62	4.00	3.00	23.09	3.00	3.25	8.78	9.43	9.75	6.50

\*\* Deformation Indicators. Note: Fittings designed only to be used on exact sizes listed.





# “The Standard” in Cell Tower Securement



When it comes to the securement of cell towers, Crosby® sets the industry standard with superior products, in-depth training, and time-tested expertise. For years, we have fulfilled the unique needs of each and every cell tower company that we’ve partnered with.



**Turnbuckle Fittings**



**Wire Rope End Fittings**



# Crosby®

NEW!

## Crosby MAGNEX™ Lifting Magnet



## Fast and Efficient Lifting for Plates, Round Steel, or Any Similarly Shaped Fabrications

- Solid steel construction with recessed area, reducing risk of damage to tags for identification and technical user information
- Fully welded construction, minimizing maintenance costs
- Innovative and patented easy switch stop block, equipped with ballbearing and ergonomic handle for increased safety and ease of use
- Individually Proof Tested to 3 times the Working Load Limit with certification
- Each product is individually serialized, with the serial number and Proof Load test date stamped on body
- User manual with test certificate included with each magnet
- 5-year warranty on magnetic system
- CE certified including test certificate in accordance with EN 13155
- Maintenance replacement kits are available
- Can be used on both flat and round steel surfaces



Rig Safe. Rig Smart. Rig Crosby.®

[thecrosbygroup.com](http://thecrosbygroup.com)



## RESIN FOR SPELTER SOCKETS

Note: For use on 416, 417, 427 and 517 spelter sockets only.



- 100% termination efficiency .
- Temperature operating range is -65° F to +240° F (-54°C to +116°C).
- Ideal for on-site applications.
- No hazardous molten metal.
- Improved fatigue life.
- Pouring temperature without booster pack is 48° F to 110° F (6.67°C to 43.3°C).
- One booster pack if pouring temperature is 35° F to 48° F (1.67°C to 8.89°C).
- Two booster packs if pouring temperature is 27° F to 35° F (-2.78°C to +1.67°C).
- Refer to Crosby® Wire Rope End Terminations Manual for more information.
- Storage temperature is 68° F (20° C) max. Store in well ventilated area away from sunlight and sources of ignition.



### APPROVALS:

Lloyds Register of Shipping

Det Norske Veritas (DNV)

United States Coast Guard

Registro Italiano Navale

Germanischer Lloyd

United States Navy

American Bureau of Shipping

ISO 17.558

DNV-OS-E304



U.S. Department of Transportation  
United States Coast Guard



### NATO Numbers:

100cc	8030-21-902-1823
250cc	8030-21-902-1824
500cc	8030-21-902-1825
1000cc	8030-21-902-1826

Witnessed and tested by American Bureau of Shipping. (ABS)

### Approximate U.S. Measurements:

250cc's Kit      1 Cup

## WIRELOCK® W416-7 Socket Compound

W416-7 Kits				Booster Pak Stock No.
Kit Size	Kit Per Case	Stock No.	Weight Each (lb)	
100	20	1039602	.62	1039603
250	12	1039604	1.25	1039605
500	12	1039606	2.54	1039607
1000	12	1039608	4.59	1039609
2000	12	1039610	9.00	1039611

## Guide to amount WIRELOCK® Required

Wire Rope Size		WIRELOCK® Required (cc)	Wire Rope Size		WIRELOCK® Required (cc)
(in)	(mm)		(in)	(mm)	
1/4	6-7	9	1-3/4	44	700
5/16	8	17	1-7/8	48	700
3/8	9-10	17	2	51	1265
7/16	11	35	2-1/8	54	1265
1/2	13	35	2-1/4	56	1410
9/16	14	52	2-3/8	60	1410
5/8	16	52	2-1/2	64	1830
3/4	20	86	2-5/8	67	1830
7/8	22	125	2-3/4	70	2250
1	26	160	3	76	3160
1-1/8	28	210	3-1/4	82	3795
1-1/4	32	350	3-1/2	88	4920
1-3/8	36	350	3-3/4	94	5980
1-1/2	40	420	4	102	7730
1-5/8	42	495	—	—	—

Wirelock is a hazardous material regulated by US DOT, ICAO/IATA and IMO for transportation.



# CROSBY® SPELTER BUTTON SB-427B

## APPLICATION INSTRUCTIONS



### Scope

This procedure is provided to give instructions for installation of wire rope into the Crosby® SB-427B Spelter Button using WIRELOCK® socketing material, or zinc socketing material. **Additionally, instructions regarding the reuse of spelter buttons are included.** The spelter button is part of a socket assembly that includes a socket basket, pin, cotter pin and button. If there are any questions regarding these instructions, please contact The Crosby Group LLC at (918) 834-4611 and request technical assistance.

NOTE: Many high performance ropes require special attention to prevent rope damage during cutting, seizing and brooming in preparation for the speltering operation. Attention to the special instructions is required to ensure proper termination efficiency. Consult rope manufacturer for specific details.

### Installation

Install button on the rope so that the live end of the rope extends out of small inside diameter of the button. Broomed end of rope should be pulled into button and placed completely to the "MAX FILL" line marked on the button to ensure correct length of engagement with socketing material.

### Socketing using WIRELOCK® Resin Material

Seizing, cleaning, brooming and preparation of wire rope and pouring of WIRELOCK® is to be carried out per instructions provided in the *Wire Rope End Terminations User's Manual*, and *WIRELOCK® Warnings and Application Instructions* located on the WIRELOCK® Product or in the Crosby General Catalog.

### Socketing Using Zinc Spelter Material

Seizing, cleaning, brooming and preparation of the wire rope, and pouring of zinc is to be carried out in accordance with recommendations of the Crosby® *Wire Rope End Terminations Manual* or other approved procedures.

Note: Before operation of the wire rope assembly, it is recommended that all poured sockets, whether with zinc or resin, be proof loaded to seat the cone.

### Reuse Of Crosby® Spelter Buttons

The following are general guidelines for the reuse of a Crosby® SB-427B Button. The use and inspection of used buttons are the responsibility of the user.

#### Procedure For Removing Spelter Cone

- Cut the rope close ( $\frac{1}{2}$ " ) to the nose end of the button and press the cone out of the button.
- For metallurgical, medical and environmental reasons, we do not recommend the use of heat to remove the spelter cone.
  - However, if this is the only means available for removing the zinc cone, care should be taken not to exceed 850°F (450°C) surface temperature. The preferred method would be a slow heat in a temperature controlled oven. If a torch (rosebud) is used, the heated area shall be monitored with a Tempil stick or a temperature indicator to prevent localized heating from exceeding the 850°F (450°C) limit.
- To remove a WIRELOCK® cone, heat the surface of the button to 350°F (177°C) (do not exceed the 850°F (450°C) limit for any localized hot spot). Leave for 5-10 minutes, then drive the cone out with a hammer and drift.

#### Selection Of Buttons For Reuse

- Use only buttons that:
  - Do not show discoloration from excessive heating.
  - Do not show any signs of welding.
  - Select only buttons that have been cleaned and have passed a Magnetic Particle Inspection by a qualified technician (level II ASNT-SNT-TC-1A-88) per ASTM E709. Acceptance criteria shall be per ASTM E125, Types II-VIII, Degree 1. No cracks are acceptable.
  - Select only buttons that do not show any signs of overloading or wear.
  - Select buttons that are free from nicks, gouges and abrasions. Indications may be repaired by lightly grinding until surfaces are smooth, provided they do not reduce the dimensions by more than 10% of the nominal catalog dimension.
  - Select buttons that are not distorted, bent or deformed.



**NOTE: Buttons having any of the indications as outlined above shall not be reused.**

# CROSBY® FORGED WIRE ROPE CLIP

## WARNINGS & APPLICATION INSTRUCTIONS



**G-450**  
**(Red-U-Bolt®)**

### ⚠ WARNING

- Failure to read, understand, and follow these instructions may cause death or serious injury.
- Read and understand these instructions before using clips.
- Match the same size clip to the same size wire rope.
- Prepare wire rope end termination only as instructed.
- Do not use with plastic coated wire rope.
- Apply first load to test the assembly. This load should be of equal or greater weight than loads expected in use. Next, check and retighten nuts to recommended torque (See Table 1).

Efficiency ratings for wire rope end terminations are based upon the minimum breaking force of wire rope. The efficiency rating of a properly prepared loop or thimble-eye termination for clip sizes 1/8" through 7/8" is 80%, and for sizes 1" through 3-1/2" is 90%.

The number of clips shown (see Table 1) is based upon using RRL or RLL wire rope, 6 x 19 or 6 x 37 Class, FC or IWRC; IPS or XIP, XXIP. If Seale construction or similar large outer wire type construction in the 6 x 19 Class is to be used for sizes 1 inch and larger, add one additional clip. If a pulley (sheave) is used for turning back the wire rope, add one additional clip.

The number of clips shown also applies to rotation-resistant RRL wire rope, 8 x 19 Class, IPS, XIP, XXIP sizes 1-1/2 inch and smaller; and to rotation-resistant RLL wire rope, 19 x 7 Class, IPS, XIP, XXIP sizes 1-1/2 inch and smaller.

For other classes of wire rope not mentioned above, we recommend contacting Crosby Engineering at the address or telephone number on the back cover to ensure the desired efficiency rating.

The style of wire rope termination used for any application is the obligation of the user.

### For OSHA (Construction) applications, see OSHA 1926.251.

1. Refer to Table 1 following these instructions. Turn back specified amount of rope from thimble or loop. Apply first clip one base width from dead end of rope. Apply U-Bolt over dead end of wire rope – live end rests in saddle (Never saddle a dead horse!). Use torque wrench to tighten nuts evenly, alternate from one nut to the other until reaching the recommended torque. (See Figure 1)



Figure 1

2. When two clips are required, apply the second clip as near the loop or thimble as possible. Use torque wrench to tighten nuts evenly, alternating until reaching the recommended torque. When more than two clips are required, apply the second clip as near the loop or thimble as possible, turn nuts on second clip firmly, but do not tighten. (See Figure 2)

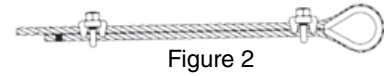

Figure 2

3. When three or more clips are required, space additional clips equally between first two – take up rope slack – use torque wrench to tighten



Figure 3

nuts on each clip evenly, alternating from one clip nut to the other until reaching recommended torque (See Figure 3).

4. If a pulley (sheave) is used in place of a thimble, add one additional clip. Clip spacing should be as shown (See Figure 4).

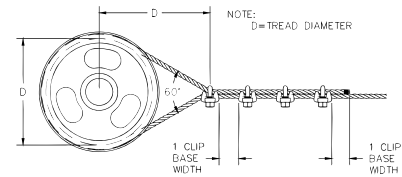

Figure 4

### 5. WIRE ROPE SPLICING PROCEDURES:

The preferred method of splicing two wire ropes together is to use inter-locking turnback eyes with thimbles, using the recommended number of clips on each eye (See Figure 5).



Figure 5

An alternate method is to use twice the number of clips as used for a turnback termination. The rope ends are placed parallel to each other,

overlapping by twice the turnback amount shown in the application instructions. The minimum number of clips should be installed on each dead end (See Figure 6). Spacing, installation torque, and other instructions still apply.

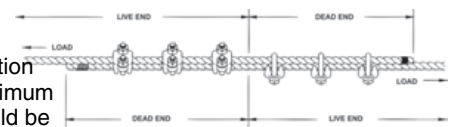

Figure 6

### 6. IMPORTANT

Apply first load to test the assembly. This load should be of equal or greater weight than loads expected in use. Next, check and use torque wrench to retighten nuts to recommended torque.

In accordance with good rigging and maintenance practices, the wire rope end termination should be inspected periodically for wear, abuse, and general adequacy.

Clip Size/ Rope Size		Minimum No. of Clips	Amount of Rope to Turn Back in inches	* Torque in ft•lbf
(in)	(mm)			
1/8	3-4	2	3-1/4	4.5
3/16	5	2	3-3/4	7.5
1/4	6-7	2	4-3/4	15
5/16	8	2	5-1/4	30
3/8	9-10	2	6-1/2	45
7/16	11-12	2	7	65
1/2	13	3	11-1/2	65
9/16	14-15	3	12	95
5/8	16	3	12	95
3/4	18-20	4	18	130
7/8	22	4	19	225
1	24-25	5	26	225
1-1/8	28-30	6	34	225
1-1/4	33-34	7	44	360
1-3/8	36	7	44	360
1-1/2	38-40	8	54	360
1-5/8	41-42	8	58	430
1-3/4	44-46	8	61	590
2	48-52	8	71	750
2-1/4	56-58	8	73	750
2-1/2	62-65	9	84	750
2-3/4	68-72	10	100	750
3	75-78	10	106	1200
3-1/2	85-90	12	149	1200

If a pulley (sheave) is used for turning back the wire rope, add one additional clip. See Figure 4.

If a greater number of clips are used than shown in the table, the amount of turnback should be increased proportionately.

\*The tightening torque values shown are based upon the threads being clean, dry, and free of lubrication.



# CROSBY® FIST GRIP® CLIPS

## WARNINGS & APPLICATION INSTRUCTIONS



**New Style Fist Grip®**  
3/16" - 5/8"



**Fist Grip® Clips**  
3/4" - 1-1/2"

### WARNING

- Failure to read, understand, and follow these instructions may cause death or serious injury.
- Read and understand these instructions before using clips.
- Match the same size clip to the same size wire rope.
- Do not mismatch Crosby clips with other manufacturer's clips.
- Prepare wire rope end termination only as instructed.
- Do not use with plastic coated wire rope.
- Apply first load to test the assembly. This load should be of equal or greater weight than loads expected in use. Next, check and retighten nuts to recommended torque (See Table 1).

Efficiency ratings for wire rope end terminations are based upon the minimum breaking force of wire rope. The efficiency rating of a properly prepared loop or thimble-eye termination for clip sizes 1/8" through 7/8" is 80%, and for sizes 1" through 3-1/2" is 90%.

The number of clips shown (see Table 1) is based upon using RRL or RLL wire rope, 6 x 19 or 6 x 37 Class, FC or IWRC; IPS or XIP, XXIP. If Seale construction or similar large outer wire type construction in the 6 x 19 Class is to be used for sizes 1 inch and larger, add one additional clip. If a pulley (sheave) is used for turning back the wire rope, add one additional clip.

The number of clips shown also applies to rotation-resistant RRL wire rope, 8 x 19 Class, IPS, XIP, XXIP sizes 1-1/2 inch and smaller; and to rotation-resistant RRL wire rope, 19 x 7 Class, IPS, XIP, XXIP sizes 1-1/2 inch and smaller.

For other classes of wire rope not mentioned above, we recommend contacting Crosby Engineering at the address or telephone number on the back cover to ensure the desired efficiency rating.

The style of wire rope termination used for any application is the obligation of the user.

### For OSHA (Construction) applications, see OSHA 1926.251.

1. Refer to Table 1 in following these instructions. Turn back specified amount of rope from thimble or loop.

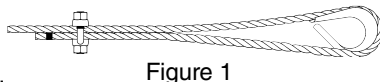

Figure 1

Apply first clip one base width from dead end of rope. Use torque wrench to tighten nuts evenly, alternating from one nut to the other until reaching the recommended torque. (See Figure 1)

2. When two clips are required, apply the second clip as near the loop or thimble as possible. Use torque wrench to tighten nuts evenly, alternating until reaching the recommended torque.

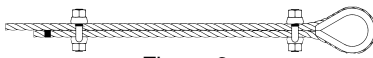

Figure 2

When more than two clips are required, apply the second clip as near the loop or thimble as possible, turn nuts on second clip firmly, but do not tighten (See Figure 2).

3. When three or more additional clips are required, space additional clips equally between first two – take up rope slack – use torque wrench to tighten nuts on each clip evenly, alternating from one nut to the other until reaching recommended torque. (See Figure 3)

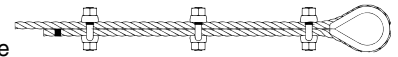

Figure 3

4. If a pulley (sheave) is used in place of a thimble, add one additional Fist Grip. Fist Grip spacing should be as shown. (See Figure 4)

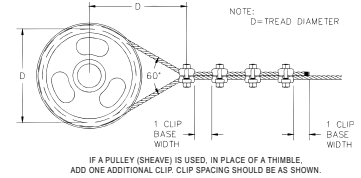

Figure 4

### 5. WIRE ROPE SPLICING PROCEDURES:

The preferred method of splicing two wire ropes together is to use inter-locking turnback eyes with thimbles, using the recommended number of clips on each eye (See Figure 5).



Figure 5

An alternate method is to use twice the number of clips as used for a turnback termination.

The rope ends are placed parallel to each other, overlapping by twice the turnback amount shown in the application instructions. The minimum number of clips should be installed on each dead end (See Figure 6). Spacing, installation torque, and other instructions still apply.

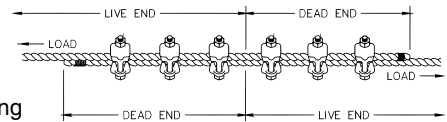

Figure 6

### 6. IMPORTANT

Apply first load to test the assembly. This load should be of equal or greater weight than loads expected in use. Next, check and use torque wrench to retighten nuts to recommended torque.

In accordance with good rigging and maintenance practices, the wire rope end termination should be inspected periodically for wear, abuse, and general adequacy.

Clip Size/ Rope Size		Minimum No. of Clips	Amount of Rope to Turn Back in Inches	* Torque in ft•lbf
(in)	(mm)			
3/16	5	2	4	30
1/4	6-7	2	4	30
5/16	8	2	5	30
3/8	9-10	2	5-1/4	45
7/16	11-12	2	6-1/2	65
1/2	13	3	11	65
9/16	14-15	3	12-3/4	130
5/8	16	3	13-1/2	130
3/4	18-20	3	16	225
7/8	22	4	26	225
1	24-25	5	37	225
1-1/8	28-30	5	41	360
1-1/4	32-34	6	55	360
1-3/8	36	6	62	500
1-1/2	38-40	7	78	500

If a pulley (sheave) is used for turning back the wire rope, add one additional clip. See Figure 4.

If a greater number of clips are used than shown in the table, the amount of turnback should be increased proportionately.

\*The tightening torque values shown are based upon the threads being clean, dry, and free of lubrication.

## CROSBY TERMINATOR

### WARNINGS & APPLICATION INSTRUCTIONS

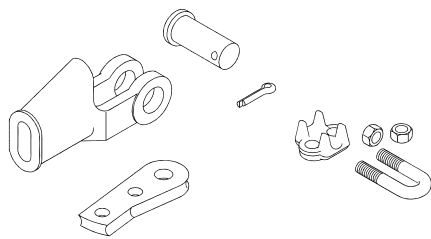

#### S-421T / US-422T CROSBY "TERMINATOR"

**NOTE:** The design of the basket for the S-421T 1-1/4" TERMINATOR® Wedge Socket does not allow proper fit to the old style Crosby S-421W wedge (see Fig. 1). **Do not assemble or use.** The design of the basket for each US-422T TERMINATOR Wedge Socket does not allow proper fit to the old style UWO-422 wedge (See Fig. 1). **Do not assemble or use.** All S-421T and US-422T TERMINATOR baskets are marked with a capital "T" or TERMINATOR.

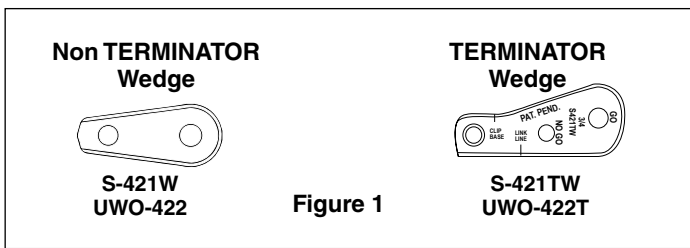

**QUIC-CHECK®** "Go" and "No-Go" features cast into wedge. The proper size wire rope is determined when the following criteria are met:  
1. The wire rope shall pass thru the "Go" hole in the wedge.  
2. The wire rope shall NOT pass thru the "No-Go" hole in the wedge.



#### Important Safety Information – Read and Follow Inspection/Maintenance Safety

- Always inspect socket, wedge and pin before using.
- Do not use part showing cracks.
- Do not use modified or substitute parts.
- Repair minor nicks or gouges to socket or pin by lightly grinding until surfaces are smooth. Do not reduce original dimension more than 10%. Do not repair by welding.
- Inspect permanent assemblies annually, or more often in severe operating conditions.
- Do not mix and match wedges or pins between models or sizes.
- Always select the proper wedge and socket for the wire rope size.

#### Assembly Safety

- Use only with standard 6 to 8 strand wire rope of designated size. For intermediate size rope, use next larger size socket. For example: When using 9/16" diameter wire rope use a 5/8" size Wedge Socket Assembly. Welding of the tail on standard wire rope is not recommended. Seizing of the tail is preferred following the recommended practices of the wire rope manufacturer. The tail length of the dead end should be a minimum of 6 rope diameters but not less than 6" (See Figure 2).
- **To use with Rotation Resistant wire rope** (special wire rope constructions with 8 or more outer strands) ensure that the dead end is welded, brazed or seized before inserting the wire rope into the wedge socket to prevent core slippage or loss of rope lay. Seizing of the tail is preferred following the recommended practices of the wire rope manufacturer. The tail length of the dead end should be a minimum of 20 rope diameters but not less than 6" (See Figure 2).
- Properly match socket, wedge and clip (See Table 1) to wire rope size.
- Align live end of rope, with center line of pin (See Figure 2).

- Secure dead end section of rope (See Figure 2).
- Tighten nuts on clip to recommended torque (See Table 1).
- Do not attach dead end to live end or install wedge backwards (See Fig. 3).
- Use a hammer to seat Wedge and Rope as deep into socket as possible before applying first load.

### WARNING

- **Loads may slip or fall if the Wedge Socket is not properly installed.**
- **Load misapplied in direct contact with the wedge can dislodge the wedge and cause loss of load.**
- **A falling load can seriously injure or kill.**
- **Read and understand these instructions before installing the Wedge Socket.**
- **Do not side load the Wedge Socket.**
- **Apply first load to fully seat the Wedge and Wire Rope in the socket. This load should be of equal or greater weight than loads expected in use.**
- **Do not interchange wedges between S-421T and US422T or between sizes.**
- **Do not assemble an old style 1-1/4" (30-32mm) S-421W wedge into an S-421T 1-1/4" (30-32mm) TERMINATOR basket.**
- **Do not assemble an old style UWO-422 wedge into a US-422T TERMINATOR basket.**

Figure 2

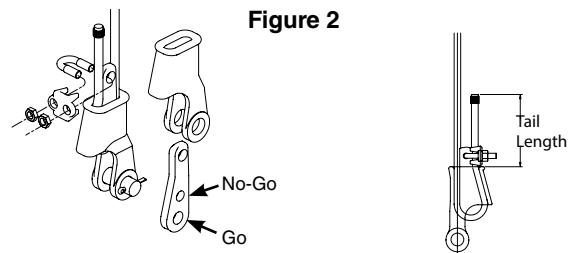

#### \*Tail Length

Standard 6 to 8 Strand Wire Rope	Rotation Resistant Wire Rope
A minimum of 6 rope diameters, but not less than 6"	A minimum of 20 rope diameters, but not less than 6"

TABLE 1

Rope Size (in)	3/8	1/2	5/8	3/4	7/8	1	1-1/8	1-1/4
Clip Size (in)	3/8	1/2	5/8	3/4	7/8	1	1-1/8	1-1/4
* Torque ft•lbf	45	65	95	130	225	225	225	360

\* The tightening torque values shown are based upon the threads being clean, dry, and free of lubrication.

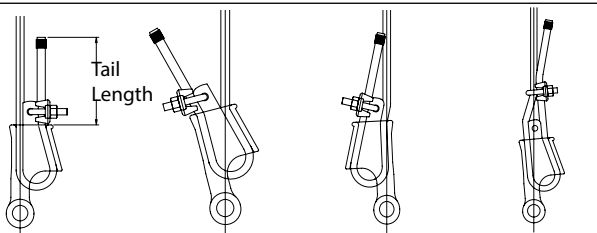

Figure 3

#### Operating Safety

- Apply first load to fully seat the Wedge and Wire Rope in the socket. This load should be of equal or greater weight than loads expected in use.
- Efficiency rating of the Wedge Socket termination is based upon the catalog breaking strength of Wire Rope. The efficiency of a properly assembled Wedge Socket is 80%.
- During use, do not strike the dead end section or wedge with any other elements of the rigging (Called two blocking).
- Do not allow a direct load to contact the wedge.

# SUPER TERMINATOR WEDGE SOCKET

## WARNINGS & APPLICATION INSTRUCTIONS

US Patented 6,898,827.

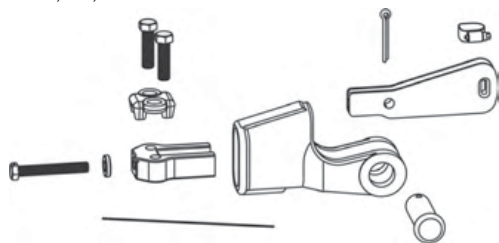

### S-423T "SUPER TERMINATOR"

The intended purpose of the SUPER TERMINATOR is to offer a Wedge Socket termination, which when assembled properly with high performance, high strength, compacted strand, rotation resistant wire rope will achieve an 80% termination efficiency. Due to the unique construction of these ropes, Crosby cannot make a broad general statement that all current and future designed ropes, when properly assembled with a SUPER TERMINATOR, will achieve a minimum 80% termination efficiency (To determine the efficiency rating for a specific rope, contact Crosby Engineering at 918-834-4611).

The SUPER TERMINATOR may be purchased as a complete Wedge Socket assembly or the Wedge assembly may be purchased for retrofit onto your Crosby S-421T wedge socket basket.

The Crosby S-423T SUPER TERMINATOR Wedge is designed to be assembled only into the Crosby S-421T socket basket. For the 1-1/4" S-423T, assemble only on to S-421T basket marked TERMINATOR.

### Important Safety Information - Read and Understand Inspection/Maintenance Safety

- Always inspect socket, wedge and pin before using.
- Do not use part showing cracks.
- Do not use modified or substitute parts.
- Repair minor nicks or gouges to socket or pin by lightly grinding until surfaces are smooth. Do not reduce original dimension more than 10%. Do not repair by welding.
- Inspect permanent assemblies annually, or more often in severe operating conditions.
- Do not mix and match wedges or pins between models or sizes.
- Always select the proper wedge and socket for the wire rope size.

### Assembly Safety

- Properly match socket and wedge assembly to wire rope size.
- Ensure the dead end is properly seized before inserting the wire rope into the wedge socket basket. High performance, high strength, compacted strand, rotation resistant wire ropes are sensitive to seizing methods. For specific seizing procedures, contact the wire rope manufacturer.
- The tail length of the dead end should be a minimum of 20 rope diameters but not less than 10" (See Fig. 1).
- Mount wedge socket basket in vice.
- Insert live end of wire rope into wedge basket, aligning live end of rope with center line of pin. Make a loop and return. (See Figure 2).
- Pull on live line to remove excess out of loop, leaving enough room to properly insert wedge into basket. (See Figure 3).
- Secure rope to SUPER TERMINATOR Wedge with clamp (See Figure 4).
- Pull Wedge and rope into basket until tensioner bolt, with washers properly applied, can engage threads in nose of wedge. Auxiliary power may be required to fully pull wedge and rope into basket. (See Figure 5).
- Use torque wrench to tighten tensioner bolt to recommended torque value, properly seating wedge and rope into basket. Reference Table 1 for recommended Torque in Ft Lbs.
- Secure dead end section of rope with clip base. Tighten bolts to recommended torque values (See Table 1).
- Properly install wire to securely lock tensioner bolt to tensioner (See Figure 6).
- Do not attach dead end to live end or install wedge backwards (See Figure 7).

### Operating Safety

- Proper application of the Super TERMINATOR eliminates the "first load" requirement of conventional wedge socket terminations.
- Efficiency rating of the Wedge Socket termination is based upon the catalog breaking strength of Wire Rope. The efficiency

of a properly assembled Super Terminator on most high performance, high strength, compacted strand, rotation resistant ropes will achieve 80% of catalog breaking strength of rope, depending on the unique construction of these ropes (To determine the efficiency rating for a specific rope, contact Crosby Engineering at 918-834-4611).

- During use, do not strike the dead end section or wedge with any other elements of the rigging (Called two blocking).
- The SUPER TERMINATOR wedge socket may also be used with standard 6 to 8 strand and rotation resistant wire rope (special wire rope constructions with 8 or more strands).
- Do not allow direct load to contact the wedge.

### WARNING

- Loads may slip or fall if the Wedge Socket is not properly installed.
- A falling load can seriously injure or kill.
- Load misapplied in direct contact with the wedge can dislodge the wedge and cause loss of load.
- Read and understand these instructions before installing the Wedge Socket.
- Do not side load the Wedge Socket.
- Apply recommended torque to tensioner and clip bolts, and properly install wire to securely lock tensioner bolt to tensioner.
- Do not assemble the S-423 Wedge in any brand or model socket basket other than the Crosby S-421T TERMINATOR.
- The size is marked on the socket basket and wedge, do not interchange wedge between sizes.

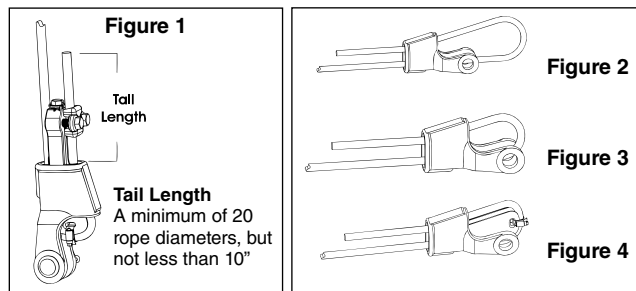

Wedge Size (in)	Tensioner Bolt Torque ft • lbf*	Clip Bolts Torque ft • lbf*
5/8	110	95
3/4	150	130
7/8	380	225
1	380	225
1-1/8	600	225
1-1/4	900	360

\* The tightening torque values shown are based upon the threads being clean, dry, and free of lubrication.

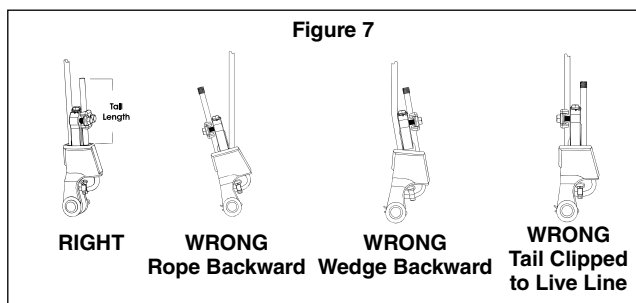
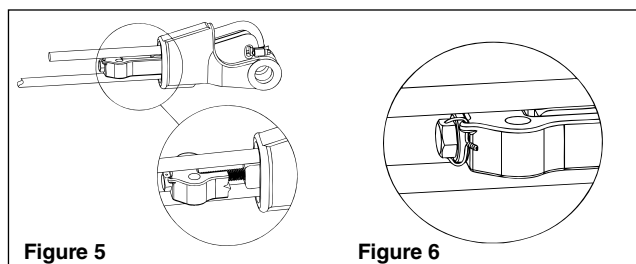



## WEDGE SOCKET

### WARNINGS & APPLICATION INSTRUCTIONS

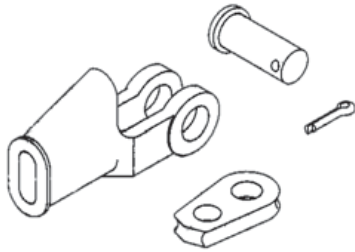

S-421 / US-422

### Important Safety Information - Read and Follow Inspection/Maintenance Safety

- Always inspect socket, wedge and pin before using.
- Do not use part showing cracks.
- Do not modify or substitute parts.
- Repair minor nicks or gouges to socket or pin by lightly grinding until surface are smooth. Do not reduce original dimension more than 10%. Do not repair by welding.
- Inspect permanent assemblies annually, or more often in severe operating conditions.
- Do not mix and match wedges or pins between models or sizes.
- Always select the wedge and socket for the wire rope size.

### Assembly Safety

- Use only with standard 6 to 8 strand wire rope of designated size. For intermediate size rope, use next larger size socket. For example: When using 9/16" diameter wire rope use a 5/8" size Wedge Socket Assembly. Welding of the tail on standard wire rope is not recommended. Seizing of the tail is preferred following the recommended practices of the wire rope manufacturer. The tail length of the dead end should be a minimum of 6 rope diameters but not less than 6".
- Align live end of rope, with center line of pin (See Figure 1).
- Secure dead end section of rope (See Figure 1).
- DO NOT ATTACH DEAD END TO LIVE END (See Figure 1).
- Use a hammer to seat Wedge and Rope as deep into socket as possible before applying first load.
- To use with Rotation Resistant wire rope (special wire rope constructions with 8 or more outer strands) ensure that the dead end is welded, brazed or seized before inserting the wire rope into wedge socket to prevent core slippage or loss of rope lay. The tail length of the dead end should be a minimum of 20 rope diameters but not less than 6" (Figure 1).

### ⚠ WARNING

- Loads may slip or fall if the Wedge Socket is not properly installed.
- Load misapplied in direct contact with the wedge can dislodge the wedge and cause loss of load.
- A falling load can seriously injure or kill.
- Read and understand these instructions before installing the Wedge Socket.
- Do not side load the Wedge Socket.
- Do not interchange Crosby wedge socket, wedge or pin with non Crosby Wedge socket, wedge or pin.
- Apply first load to fully seat the Wedge and Wire Rope in the socket. This load should be of equal or greater weight than loads expected in use.
- Do not interchange wedge between S-421 and US-422 or between sizes.

Figure 1

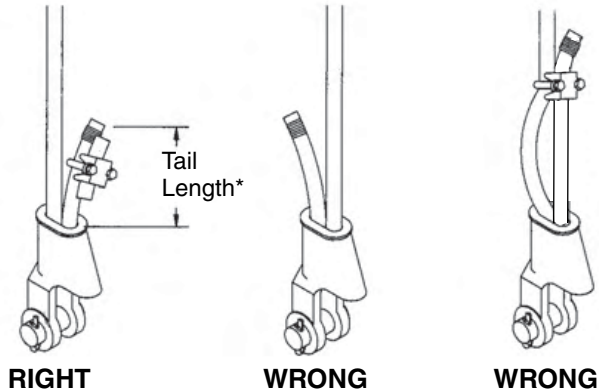

\*Tail Length  
Standard 6 to 8 strand wire rope  
A minimum of 6 rope diameters, but not less than 6"  
(i.e. - For 1" rope: Tail Length = 1" x 6 = 6")

Rotation Resistant Wire Rope  
A minimum of 20 rope diameters, but not less than 6"  
(i.e. - For 1" rope: Tail Length = 1" x 20 = 20")

### Operating Safety

- Apply first load to fully seat the Wedge and Wire Rope in the socket. This load should be of equal or greater weight than loads expected in use.
- Efficiency rating of the Wedge Socket termination is based upon the catalog breaking strength of Wire Rope. The efficiency of properly assembled Wedge Socket is 80%.
- During use, do not strike the dead end section with any other elements of the rigging (Called two-blocking).
- Do not allow a direct load to contact the wedge.

# CROSBY® SHANK HOOKS FOR SWAGING WARNINGS & APPLICATION INSTRUCTIONS

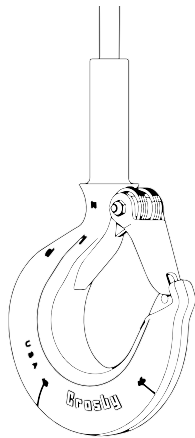

**S-319SWG**

- S-319SWG hooks are recommended for use with 6 x 19 or 6 x 37, IPS or XIP (EIP), XXIP (EEIP), RRL, FC or IWRC wire rope. Before using any National Swage fitting with any other type lay, construction or grade of wire rope, it is recommended that the termination be destructively tested and documented to prove the adequacy of the assembly to be manufactured.
- Use only Crosby shank hooks designed exclusively for swaging.
- A visual periodic inspection for cracks, nicks, wear gouges and deformation as part of a comprehensive documented inspection program should be conducted by trained personnel in compliance with the schedule in ASME B30.10.
- For hooks used in frequent load cycles or pulsating loads, the hook should be periodically inspected by magnetic particle or dye penetrant.
- Never use a hook whose throat opening has been increased, or whose tip has been bent more than 10 degrees out of plane from the hook body, or is in any other way distorted or bent.
- Note: A latch will not work properly on a hook with a bent or worn tip.
- Never use a hook that is worn beyond the limits shown in Figure 1.

- Remove from service any hook with a crack, nick, or gouge. Hooks with a nick or gouge shall be repaired by grinding lengthwise, following the contour of the hook, provided that the reduced dimension is within the limits shown in Figure 1. Contact Crosby Engineering to evaluate any crack.

**⚠ WARNING**

- Loads may disengage from hook if proper procedures are not followed.
- A falling load may cause serious injury or death.
- See OSHA Rule 1926.1431(g)(1)(i)(A) and 1926.1501(g)(4)(iv)(B) for personnel hoisting by cranes or derricks. A Crosby 319 hook with a PL Latch attached (when secured with bolt, nut and pin) may be used for lifting personnel. A Crosby S-319N hook with an S-4320 Latch attached (when secured with cotter pin or bolt, nut and pin) may be used for lifting personnel.
- Hook must always support the load. The load must never be supported by the latch.
- Never exceed the Working Load Limit (WLL) of the wire rope and hook system.
- Read and understand “National Swage Swaging Products and Procedures” manual before swaging the hook.

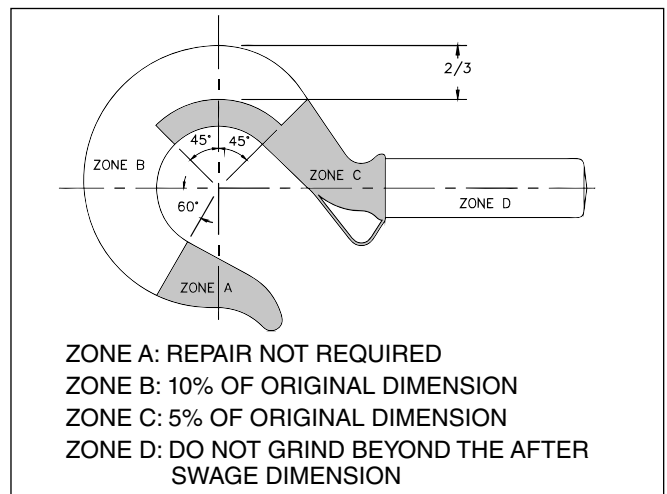

Figure 1

## Warning and Application Instructions For Crosby® Hook Latch Kit

### Important Safety Information – Read & Follow

- Always inspect hook and latch before using.
- Never use a latch that is distorted or bent.
- Always make sure spring will force the latch against the tip of the hook.
- Always make sure hook supports the load. The latch must never support the load (See Figures 1 & 2).
- When placing two (2) sling legs in hooks, make sure the angle between the legs is less than 90° and if the hook or load is tilted, nothing bears against the bottom of this latch (See Figures 3 & 4).
- Latches are intended to retain loose sling or devices under slack conditions.

- Latches are not intended to be an anti-fouling device.

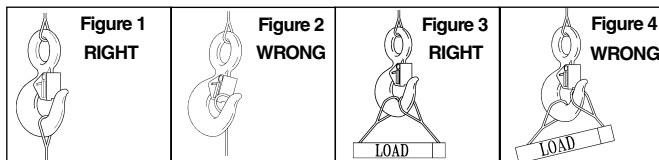

**⚠ WARNING**

- Loads may disengage from hook if proper procedures are not followed.
- A falling load may cause serious injury or death.
- See OSHA Rule 1926.1431(g)(1)(i)(A) and 1926.1501(g)(4)(iv)(B) for personnel hoisting for cranes and derricks. Only a Crosby or McKissick hook with a PL Latch attached and secured with bolt, nut and cotter (or Crosby Toggle Pin) or a Crosby hook with an S-4320 Latch attached and secured with a cotter pin, or a Crosby SHUR-LOC® hook in the locked position may be used for any personnel hoisting. A hook with a Crosby SS-4055 latch attached shall NOT be used for personnel lifting.
- Hook must always support the load. The load must never be supported by the latch.
- Read and understand these instructions before using hook and latch.

- Never repair, alter, rework, or reshape a hook by welding, heating, burning, or bending.
- Never side load, back load, or tip load a hook (See Figure 2).
- The use of a latch may be mandatory by regulations or safety codes; e.g., OSHA, MSHA, ASME B30, insurance, etc. (Note: When using latches, see instructions in *Understanding: The Crosby Group Product Warnings* for further information.)
- Always make sure the hook supports the load (See Figure 3). The latch must never support the load (See Figure 4).
- When placing two (2) sling legs in hook, make sure the angle from the vertical to the outermost leg is not greater than 45°, and the included angle between the legs does not exceed 90°\* (See Figure 5).

\* For angles greater than 90°, or more than two (2) legs, a master link or bolt type anchor shackle should be used to attach the legs of the sling to the hook.

- See ASME B30.10 “Hooks” for additional information.
- In accordance with ASME B30.9, all slings terminated by swaging shall be proof tested.
- S-319SWG hooks are designed to be a component of a system, and therefore rated based on the working limit of the system of which they are attached.
- The frame code on each S-319SWG hook is to facilitate proper latch selection only, and has no reference to the working load limit of the hook.

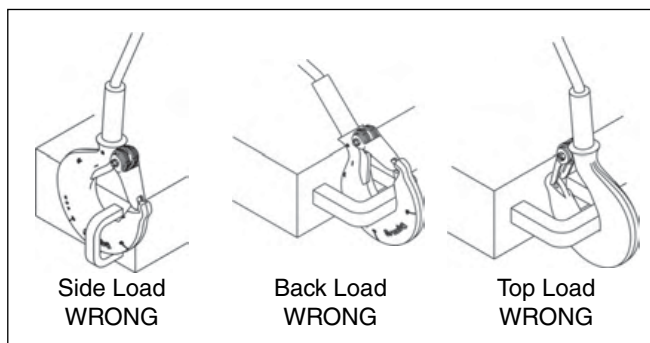

**Figure 2**

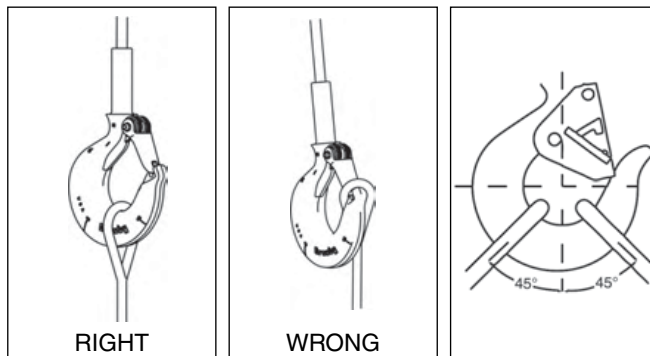

**Figure 3**

**Figure 4**

**Figure 5**

Wire Rope Size (in)	Hook Frame I.D. Code†	Required Swaging Die		Maximum After Swage Dimensions (in)
		Stock No.	Description	
3/16	DC	1191621	1/8" Swage Button Die	0.40
1/4	FC	1192845	1/4" Swage Socket Die	0.46
5/16	GC	1191621	1/4" Swage Button Die	0.58
5/16	HC	1192863	3/8" Swage Socket Die	0.71
3/8	HC	1192863	3/8" Swage Socket Die	0.71
7/16	IC	1192881	1/2" Swage Socket Die	0.91
1/2	IC	1192881	1/2" Swage Socket Die	0.91
9/16	JC	1192907	5/8" Swage Socket Die	1.16
5/8	JC	1192907	5/8" Swage Socket Die	1.16
3/4	KC	1192925	3/4" Swage Socket Die	1.42
7/8	LC	1192949	7/8" Swage Socket Die	1.55
1	NC	1192961	1" Swage Socket Die	1.80
1-1/8	OC**	1192989	1-1/8" Swage Socket Die	2.05

\*\* S319C Style Hook † See tables on pages 121 - 122 for correct latch per Hook ID Code.



# WIRELOCK®

## WARNINGS & APPLICATION INSTRUCTIONS

### ⚠ WARNING

- Incorrect use of WIRELOCK® can result in an unsafe termination which may lead to serious injury, death, or property damage.
- Do not use WIRELOCK® with stainless steel rope in salt water environment applications.
- Use only soft annealed iron wire for seizing.
- Do not use any other wire (copper, brass, stainless, etc.) for seizing.
- Never use an assembly until the WIRELOCK® has gelled and cured.
- Remove any non-metallic coating from the broomed area.
- Non Crosby sockets with large grooves need to have those grooves filled before use with WIRELOCK®.
- Read, understand, and follow these instructions and those on product containers before using WIRELOCK®.

The following simplified, step-by-step instructions should be used only as a guide for experienced, trained users. *For full information, consult the Wire Rope End Terminations Manual, API (American Petroleum Institute) Recommended Practice 9B, ISO Standards, Wire Rope Manufacturers Catalogs, and Wire Rope Sling Users Manual.*

### STEP 1 – SOCKET SELECTION

1. WIRELOCK® is recommended for use with Crosby 416-417 Spelter Sockets. Structural strand requires a socket with the basket length approximately 5 times the strand diameter or fifty (50) times the wire diameter, whichever is greater, to achieve 100% efficiency. Consult the Wire Rope End Terminations Manual for proper selection of Wire Rope or Structural Strand sockets.
2. For use with sockets other than Crosby 416-417 consult the socket manufacturer or Crosby Engineering.
3. Sockets used with WIRELOCK® shall comply with Federal or International (CEN, ISO) Standards.
4. WIRELOCK®, as with all socketing media, depends upon the wedging action of the cone within the socket basket to develop full efficiency. A rough finish inside the socket may increase the load at which seating will occur. Seating is required to develop the wedging action.

### STEP 2 – MEASURE AND SEIZE

The rope ends to be socketed should be of sufficient length so that the end of the unalaid wires (from the strands) will be at the top of the socket basket. Seizing should be placed at a distance from the end equal to the length of the basket of the socket.

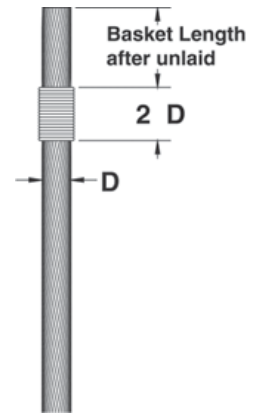

### STEP 3 – BROOMING

1. Unlay the individual strands and fully broom out the wires of the wire rope and IWRC as far as the seizing. The wires should be separated but not straightened.
2. Cut out any fiber core.
3. Unlay the individual wires from each strand, including the IWRC, completely, down to the seizing.
4. Remove any plastic material from broomed area.



### STEP 4 – CLEANING

1. The method of cleaning will depend on the lubricant and/or coating on the wire.
2. The methods and materials used for cleaning should comply with the current EPA or local regulations.
3. Consult your Wire Rope supplier or Wire Rope manufacturer for recommended material and methods. Follow the solvent supplier's recommendations for cleaning the broomed end.
4. Allow the broom to dry thoroughly.

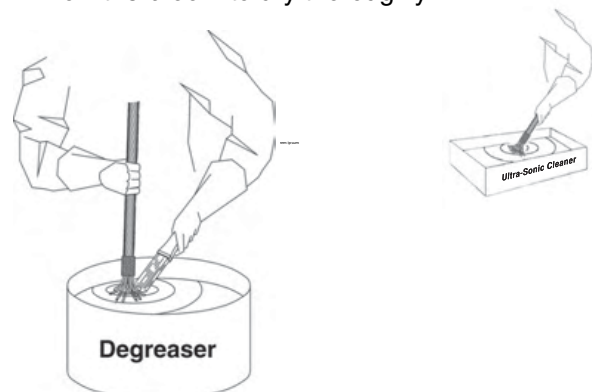

### STEP 5 – POSITIONING OF SOCKET

1. Position socket over the broom until it reaches the seizing on the wire rope. The wires should be LEVEL with the top of the socket basket.
2. Clamp rope and socket vertically ensuring alignment of their axes.
3. **CAUTION: DO NOT USE OVERSIZED SOCKETS FOR WIRE ROPE.**

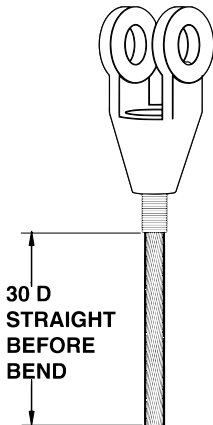

### STEP 6 – SEAL SOCKET

Seal the base of the socket with putty or plasticine to prevent leakage of the **WIRELOCK®**.



### STEP 7 – WIRELOCK® KITS

1. **WIRELOCK®** kits are pre-measured and consist of two (2) containers – one (1) with resin and one (1) with granular compound.
2. Use the complete kit – **NEVER MIX LESS THAN THE TOTAL CONTENTS OF BOTH CONTAINERS.**
3. Each kit has a shelf life clearly marked on each container and this must be observed. **NEVER USE OUT-OF-DATE KITS.**

### STEP 8 – MIXING AND POURING

1. Mix and pour **WIRELOCK®** within the temperature range of 48° to 110° F. Booster kits are available for reduced temperatures.
2. Wirelock is set up to gel in 20 minutes at 65° F. For every 18° F rise in temperature the gel time will halve. At 83° F the gel time will be 10 minutes and at 101° F it will be 5 minutes. To give extra working time of pot life it is worth considering refrigerating the kits for two hours prior to mixing and pouring. The socket should also be as cool as possible - out of direct sunlight, as an example.
3. Pour all the resin into a container containing all the granular compound and mix thoroughly for two (2) minutes with a flat paddle.
4. The **WIRELOCK®** will turn a green blue color. If it does not turn a green blue after mixing, **DO NOT USE.**
5. Immediately after mixing, slowly pour the mixture down one side of the socket until the socket basket is full.
6. Check for leakage at nose of socket, add putty if required.

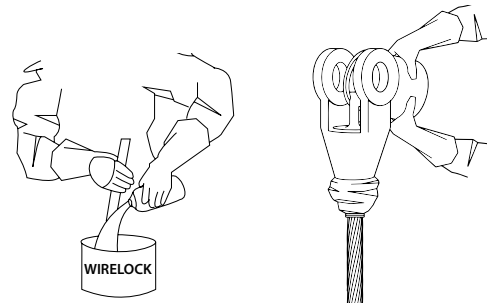

### STEP 9 – CURING

**WIRELOCK®** will gel in approximately 20 minutes, in a temperature range 65° F (18° C) to 75° F (24° C).

1. The socket must remain undisturbed in the vertical position for an additional ten (10) minutes after gel is complete.
2. The socket will be ready for service 60 minutes after gelling.
3. Never heat sockets to accelerate gel or curing.



### STEP 10 – RE-LUBRICATION

Re-lubricate wire rope as required.

### STEP 11 – PROOF LOADING

Whenever possible, the assembly should be proof loaded. In accordance with ASME B30.9.

### ALTERNATE SEIZING AND BROOMING METHOD

Reference the **Wire Rope End Terminations User's Manual** from Crosby for an alternative socketing method.

#### **CAUTION**

- **WIRELOCK®** resin, in liquid state, is flammable.
- Chemicals used in this product can give off toxic fumes and can burn eyes and skin.
- Never use out-of-date material.
- Use only in well-ventilated work areas.
- Never breathe fumes directly or for extended time.
- Always wear safety glasses to protect eyes.
- Always wear gloves to protect hands.
- Avoid direct contact with skin anywhere.

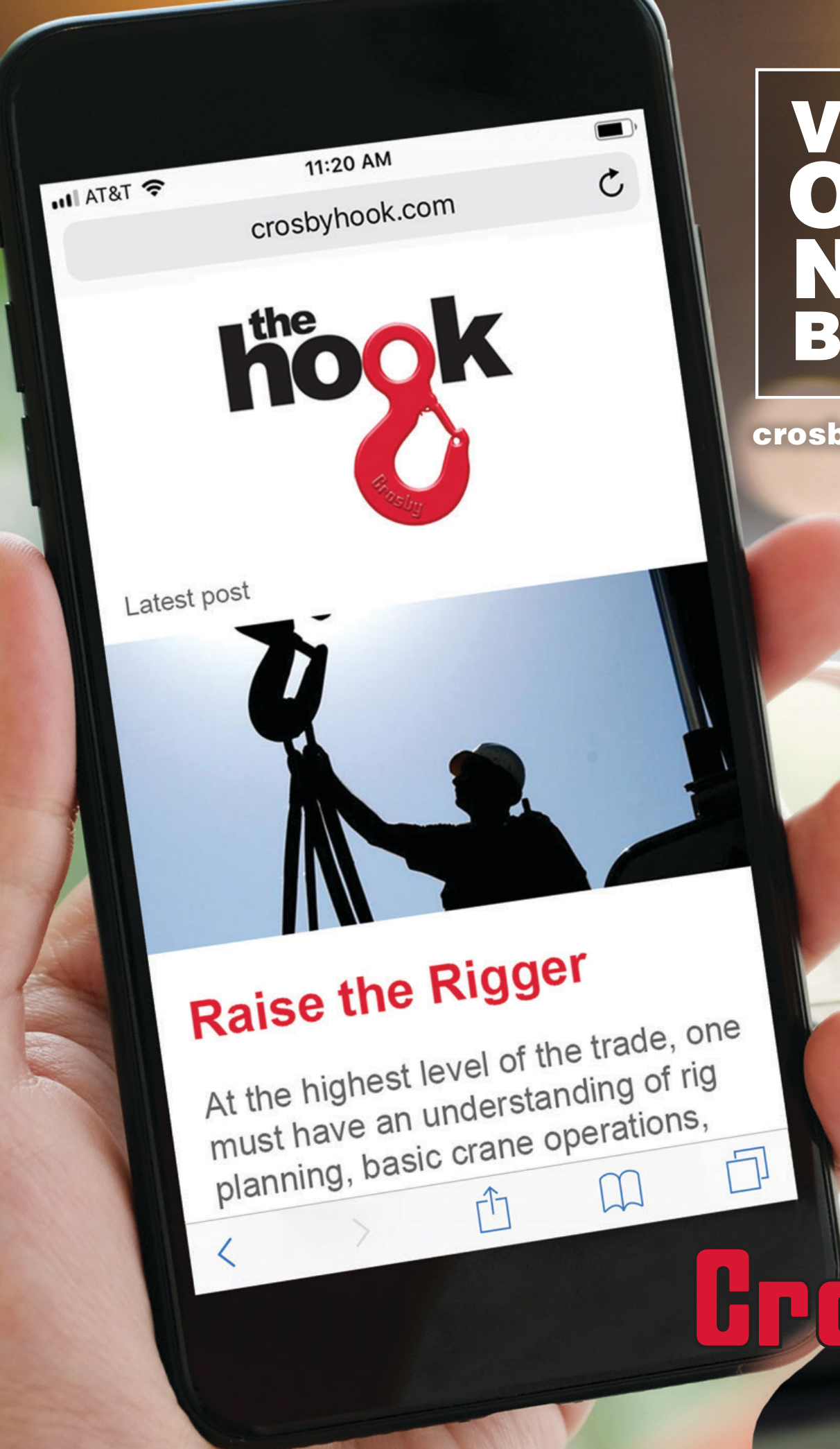

11:20 AM

AT&T

crosbyhook.com



Latest post



## Raise the Rigger

At the highest level of the trade, one must have an understanding of rig planning, basic crane operations,



**VISIT  
OUR  
NEW  
BLOG**

[crosbyhook.com](http://crosbyhook.com)

**Crosby**<sup>®</sup>



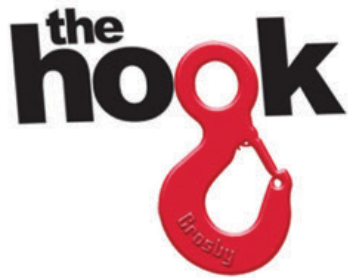

in f t i

## Raise the Rigger

The industry is evolving at a rapid pace. Helicopters are now utilized as lifting equipment to move loads, while other forms of transportation often require an element of securing the load to prevent unintentional movement. Rigging is often the last line of defense between success and disaster. Lives, limbs, and property are constantly at stake, only further emphasizing the need for widespread competency.

Today's riggers must understand the regulations and standards that apply. It represents progress that there is now a better comprehension of basic, intermediate, advanced, certified, and qualified rigger competencies. [Read more](#)



### Recent posts

[Slings: Angles & Multiples](#)

[Raise the Rigger](#)

[Advancements in wireless rope calibration](#)

### Tweets

**Crosby**



# Crosby®



**VISIT  
OUR  
NEW  
BLOG**

# **New from the global leader in rigging, lifting and securement**

Stay informed about the latest industry insights  
and trends at [crosbyhook.com](https://www.crosbyhook.com).



# STAY INFORMED ABOUT CROSBY



Logos shown are the property of their respective owners. Use does not constitute product endorsement.

Follow the leader  
in rigging, lifting  
and securement

# Crosby<sup>®</sup>

#rigcrosby  
#knowtheload



## NATIONAL DIE INFORMATION

### CAUTION

- **Improper die selection could result in significant loss of efficiency in the termination.**

National dies and die holders are made solely for swaging properly designed fittings on wire rope, and any other uses are prohibited.

The swaging operation results in a high degree of cold metal flow. The movement that occurs between the fitting and the dies will cause wear of the dies. Therefore, to prolong the life of the dies, it is important to always lubricate die faces and cavities between each pass with a light weight oil or high pressure grease.

When scores appear in the die cavities, the dies should be removed from service.

### **NEVER EXCEED THE WORKING LOAD LIMIT OF DIES OR DIE HOLDERS.**

All National Standard dies 1/4" through 1" include an open channel die cavity and a tapered die cavity in the same die block.

#### **Dies for S-505 Standard Steel Sleeves (Flemish Eyes)**

*Die sizes for 1/4" through 1"*

Swaging 1/4" through 1" Standard Steel S-505 sleeves on Flemish Eye terminations requires the use of the taper cavity only. Refer to page 24 of the *Wire Rope End Termination User's Manual* for proper die selection.

*Die sizes for 1-1/8" and above*

Swaging 1-1/8" and larger Standard Steel S-505 sleeves on Flemish Eye terminations requires using 2 sets of open channel dies (1st stage and 2nd stage) for each size. Beginning with the 1st stage die and finishing with the 2nd stage die will achieve proper after swage dimensions. Dies for S-505 Sleeves 1-1/8" and larger are single cavity with open channel. Refer to page 24 of the *Wire Rope End Termination User's Manual* for proper die selection.

#### **Using S-505 Sleeves with Metric Ropes**

Although Crosby National S-505 Standard Steel sleeves are designed to be used with most metric ropes, there are selected "intermediate" sizes of metric ropes that when swaged in standard National dies utilizing Crosby National S-505 sleeves do not achieve required after swage dimensions and efficiencies. To ensure all 505 sleeves achieve the required efficiency when used with metric ropes, Crosby provides special National swaging dies to be used in conjunction with selected size metric ropes. These new dies will produce the required efficiencies and after swage dimensions.

The table found on page 46 of this catalog or page 25 of the *Wire Rope End Termination User's Manual* identifies the new dies that are required to properly swage the selected intermediate size wire ropes not covered in the standard product offering found on page 45 of this catalog or page 24 of the manual.

*Dies for 6mm through 26mm (except 12mm, 20mm and 24mm)*

Swaging on 6mm through 26mm metric ropes for Flemish Eye slings requires the selection of the proper S-505 Standard Steel sleeve and the use of the tapered cavity only. Refer to page 24 of the *Wire Rope End Termination User's Manual* for proper sleeve and die selection.

*Dies for 12mm, 20mm and 24mm*

Swaging on 12mm, 20mm and 24mm metric ropes for Flemish Eye slings requires the selection of the proper S-505 Standard Steel sleeve and the use of both the open cavity and tapered cavity in special dies. Refer to page 25 of the *Wire Rope End Termination User's Manual* for proper sleeve and die selection.

*Dies for 28mm and larger*

Swaging on 28mm and larger metric ropes for Flemish Eye slings requires the selection of the proper S-505 Standard Steel sleeve and the use of 2 sets of open channel dies (1st stage and 2nd stage) for each size. Beginning with the 1st stage die and finishing with the 2nd stage die will achieve proper after swage dimensions. Dies for S-505 sleeves 28mm and larger are single cavity with open channel. Refer to page 24 of the *Wire Rope End Termination User's Manual* for proper sleeve and die selection.

Important: If the specific size metric rope required is not listed on page 24 of the *Wire Rope End Termination User's Manual* refer to Intermediate Metric Die Chart on page 25 of the manual for proper sleeve and die selection.

*Dies for QUIC-PASS® Swaging System – 1/4" through 1-1/2"*

The QUIC-PASS® swaging system allows "Flemish style" wire rope terminations to be swaged in only two passes. This is accomplished while maintaining currently published efficiency ratings and utilizing National Swage S-505 Standard "COLD TUFF"® Steel Sleeves.

The special design of the QUIC-PASS® dies allows the swaging process to be completed in just two passes, resulting in a 50-75% reduction in the number of passes required with conventional swaging systems. Unlike standard round dies, the QUIC-PASS® dies close completely with each pass, resulting in an increase in overall swaging process efficiencies (the job can be performed quicker), a reduction in the complexity of swaging (the concern for excess flashing between dies has been eliminated) and a reduction in training time needed for operators (more user friendly).

The finished sleeve has a "Hex" appearance that provides a QUIC-CHECK® look to determine if the termination has been swaged and provides a flat surface that allows for ease of I.D. stamping on the finished sleeve. Refer to page 24 of the *Wire Rope End Termination User's Manual* for proper die selection.

**Dies for S-501 & S-502 Swage Sockets**

Swaging all S-501 & S-502 Swage Sockets requires the use of single cavity die. This is a special die designed with a relief for swage sockets and extra length to swage the full length of the shank. Refer to pages 36 and 37 of the *Wire Rope End Termination User's Manual* for proper die selection.

*Swage Sockets for Spiral Strand Rope*

Our tests indicate that if the spiral strand is 1 x 19 or greater, and the ultimate strength does not exceed Table 1 of ASTM A586, you can use dies for size swage sockets up to the 1-1/4". For sizes greater than 1-1/4" the following will apply:

1. Closed S-502 Sockets: One (1) socket size larger with shank modified for actual strand diameter 1-3/8" through 2".
2. Open S-501 Sockets: One (1) socket size larger with shank modified for actual strand diameter 1-3/8" through 2".
3. If the strand is of greater strength than Table 1 of ASTM A586 or has less metallic area, we must recalculate the design and test for adequacy.

**Dies for S-506 Turnback Sleeves**

Turnback eye terminations using 5/16" through 1" S-506 Sleeves utilize the S-505 Standard Steel Sleeve die (1st Stage open channel die only). The 1-1/4" S-506 Sleeve utilizes the 1-3/8" socket (S-501 and S-502) die. Refer to page 46 of the *Wire Rope End Termination User's Manual* for proper die selection.

**Dies for S-409 Buttons**

Buttons are swaged in open channel dies. Refer to page 42 of the *Wire Rope End Termination User's Manual* or page 47 of this catalog for proper die selection.

Specific recommended swaging practices can be found in each product section of this catalog. The proper die selection and the recommended maximum after swage dimensions are referenced in the section of this catalog that contains the product you are swaging. This information can also be found in the National Swage Die Guide, or by referring to the National Swage Die Chart.

Dies and die adapters to fit other type swaging machines are available upon request (Refer to page 19 of the *Wire Rope End Termination User's Manual*).



**Single Cavity Die**

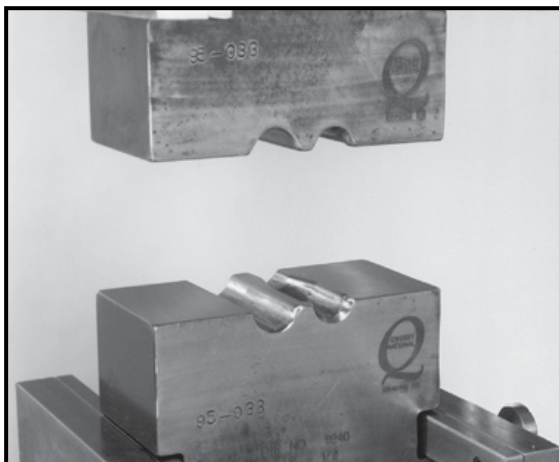

**Two Cavity Die**



**Never use dies that are cracked, worn or abraided (galled).**

## After Swage Inspection Procedures

### ⚠ WARNING

- Read, understand, and follow these instructions before using the National QUIC-PASS® Swaging System.
- Improper after swage dimensions can result in sling failure resulting in property damage, serious injury or death.
- Always gauge or measure the after swage dimensions to ensure proper sling performance.
- Using National Swaging System with ropes and termination styles other than shown in these procedures may reduce the performance of the termination and lead to premature failure.
- When using rope constructions other than shown in this procedure, the termination must be destructive tested and documented to prove adequacy of the assembly to be manufactured.
- The QUIC-PASS® Swaging System is designed only for “Flemish Eye” terminations using National S-505 Standard Steel Sleeves.
- The QUIC-PASS® Swaging System is not designed for Cable-Laid wire rope slings.

### Checking Swaging Dimensions

One of the important considerations in producing a quality termination is the overall diameter of the fitting after the swaging process is complete. Since all dies wear, and the swaged fitting used in terminations has spring back, the results of swaging should be checked periodically to determine the wear condition of the die as well as to ensure the fitting is swaged to proper dimensions.

### Key Facts About After Swage Dimensions:

1. In addition to worn dies, not achieving the proper after swage dimension can also be due to the die not being fully closed during swaging. Dies showing excessive wear should be replaced.
2. The effective swaging that dies can accomplish stops when the die lands touch each other. Any continued swaging adds needless wear and strain on the dies and swaging machine.
3. By placing a light oil on the die faces and in the cavity, the dies will be lubricated as well as protected.
4. The oozing of the oil from the faces of the dies as they touch will indicate when the dies have closed. At this point, stop the swaging cycle.
5. Additional swaging adds needless wear and strain to the dies and swaging machine.
6. Never use dies that are cracked, worn or abraded (galled).
7. The Crosby Group does not recommend the checking of die dimensions as an acceptable method of determining the quality of a swage sleeve, button, ferrule, or socket.
8. It is our recommendation that the checking of the after swage dimension of the swaged fitting is the most accurate indicator of a properly swaged termination. Measuring the die cavity only is not an acceptable process control check.
9. If the die cavity wears, the dies are not closed completely during swaging. If an inadequate number of presses are used, it could be quickly identified by checking the after swage dimension of the part.
10. Swaging Machine not producing sufficient tonnage will affect after swage dimensions.

### No-Go Gauge Information

To assist in checking the after swage dimensions of the fitting, the Crosby Group provides the National No-Go Gauges. When used correctly the National No-Go Gauges can determine if the fittings were swaged to the proper diameter. We would recommend that all Crosby products or product swaged in Crosby dies be checked with the proper gauge to determine the acceptability of the swaging process.

- Gauges are made of hardened alloy steel and machined to strict tolerances.
- Gauge can be used to verify that all fittings have been swaged properly.
- After swage dimensions not within the maximum limits may result from worn dies or improper swaging techniques.
- Other type gauges are available upon request.
- National No-Go Gauges are available for a variety of products (See Table 1).
- **No-Go Gauges and QUIC-PASS® No-Go Gauges are not interchangeable.**

Table 1 - Standard Round No-Go Gauges		
Fitting	Size	Part No.
505 Sleeve	1/4 - 7/8	1095512
505 Sleeve	1 - 1-1/2	1095521
505 Sleeve	1-3/4	1095530
505 Sleeve	2	1095549
505 Sleeve	2-1/4	1095558
505 Sleeve	2-1/2	1095567
505 Sleeve	2-3/4	1095576
505 Sleeve	3	1095585
505 Sleeve	3-1/2	1095594
505 Sleeve	3-3/4	1095601
505 Sleeve	4	1095610
501/502 Socket	1/4 - 1	1095647
501/502 Socket	1-1/8 - 1-3/4	1095656
501/502 Socket	2	1095665

### Using No-Go Gauges

When swaged properly, the gauge will go up and down (see Figure 1) and around the full length of the fitting (see Figure 2).

For the proper after swage dimensions, see the section in this publication for the specific product you are swaging.

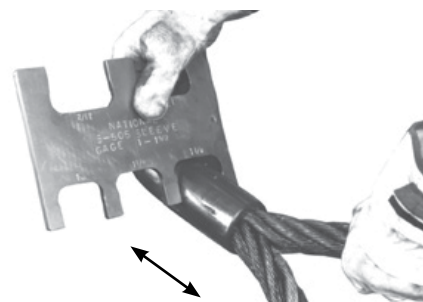

Figure 1

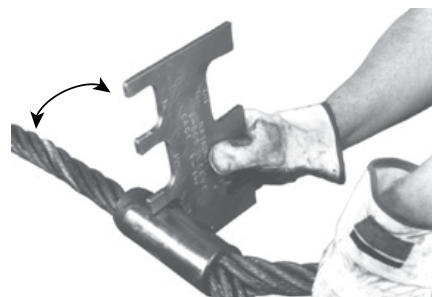

Figure 2



## QUIC-PASS® No-Go Gauges

As a further aid, QUIC-PASS® No-Go gauges are available for checking the sleeve's dimensions after swaging is complete.

- Gauges are made of hardened alloy steel and machined to strict tolerances.
- Gauge can be used to verify that all sleeves have been swaged properly.
- "After Swage" dimensions not within the maximum limits may result from worn dies or improper swaging techniques.
- **No-Go Gauges and QUIC-PASS® No-Go Gauges are not interchangeable.**

QUIC-PASS® No-Go Gauges	
Sleeve and Size	Stock No.
No-Go Gauge for S-505 1/4" - 7/8"	1923705
No-Go Gauge for S-505 1" - 1-1/4"	1923712
No-Go Gauge for S-505 1-3/8" - 1-1/2"	1923714

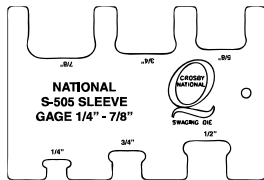

**Stock No.  
1923705**

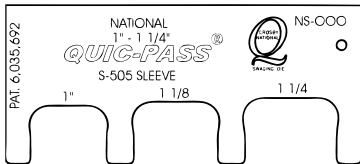

**Stock No.  
1923712**

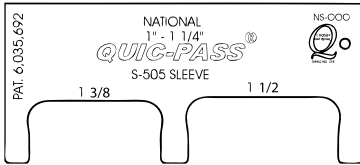

**Stock No.  
1923714**

Use a National QUIC-PASS® No-Go Gauge to check the after swage dimensions to ensure that it has been swaged to the proper dimension. When swaged properly, the gauge will slide up and down the full length of the sleeve on all three sets of opposing flats.

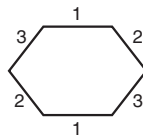

## QUIC-PASS® Maximum After Swage Dimensions

Size (in)	Maximum "After Swage" Dimension (in)
1/4	0.565
5/16 - 3/8	0.769
7/16 - 1/2	1.016
9/16 - 5/8	1.247
3/4	1.475
7/8	1.738
1	1.955
1-1/8	2.170
1-1/4	2.405
1-3/8	2.610
1-1/2	2.835

## Important Safety Information

- **Crosby does not recommend** a "Texas Tuck" style termination with Crosby National S-505 "COLD TUFF®" Standard Steel Sleeves.
- Only Crosby National S-505 "COLD TUFF®" Standard Steel Sleeves are recommended when using the QUIC-PASS® Swaging System.
- National S-505 Standard Steel Sleeves, when used with the QUIC-PASS® Swaging System, are only recommended for use with one (1) part 6 X 19 or 6 X 37, IPS or XIP (EIP), XXIP (EEIP), RRL, IWRC rope.
- The condition of the swaging machine can cause sleeve "After Swage" size not to be within the proper dimensions. Example: worn bushings, loose tie rods, loose die holders, misaligned platens, worn pins, worn linkage, etc.
- Swaging dies being worn, damaged, misused, or undersized can cause sleeve "After Swage" size not to be within the proper dimension.
- Swaging die holders excessively worn, damaged, misused or loose can cause sleeve "After Swage" size not to be within the proper dimension. Only use QUIC-PASS® dies and die holders inspected and properly secured in National swaging machines.
- Always refer to Warning and Application information found in this catalog and *Wire Rope End Terminations User's Manual*.



# SHACKLES

With Product Warning and Application Information





G-209

Crosby®

"There is No Equal"

The Market Leader: Yesterday Today and Tomorrow



G-2130

## Shackles

**DESIGN**

The theoretical reserve capability of carbon shackles should be as a minimum 5 to 1, and alloy shackles a minimum of 5 to 1\*. Known as the DESIGN FACTOR, it is usually computed by dividing the catalog ultimate load by the working load limit. The ultimate load is the average load or force at which the product fails or no longer supports the load. The working load limit is the maximum mass or force which the product is authorized to support in general service. The design factor is generally expressed as a ratio such as 5 to 1. Also important to the design of shackles is the selection of proper steel to support fatigue, ductility and impact properties.

**THE COMPETITION**

**Ask:** What is the Working Load Limit and design factor for shackles?

**Ask:** Is deformation upon overloading a critical consideration in their design?

**Ask:** Do they jeopardize other properties by having hardness high in order to increase working load or design factor?

Crosby®

Crosby carbon shackles have the highest design factor (6 to 1) in the industry. All of Crosby's design factors are documented. Crosby purchases only special bar forging quality steel with cleanliness and guaranteed harden ability. All material chemistry is independently verified prior to manufacturing. The design of Crosby shackles assures that strength, ductility and fatigue properties are met.

Load Rated®

**CLOSED DIE FORGED**

The proper performance of premium shackles depends on good manufacturing techniques that include proper forging and accurate machining. Closed die forging of shackles assures clear lettering, superior grain flow, and consistent dimensional accuracy. A closed die forged bow allows for an increased cross section that, when coupled with quench and tempering, enhances strength and ductility. Closed die bow forgings combined with close tolerance pin holes assures good fatigue life. Close pin-to-hole tolerance has been proven to be critical for good fatigue life, particularly with screw pin shackles.

**THE COMPETITION**

**Ask:** Are their shackles closed die forged with close tolerance pin holes?

**Ask:** Do their shackles have good fatigue life?

**Ask:** Do their shackles have a fatigue life that meets the new world standards?

Many forge bows utilize an open die forging process which allows for inconsistent dimensional accuracy and increased pin hole clearance, thus jeopardizing the fatigue life of the shackle in actual use.

Crosby®

Each shackle is closed die forged. Closed die forging produces consistent dimensions. A closed die forged bow allows for an increased cross section that, when coupled with quench and tempering, enhances strength and ductility. Close tolerance holes and concentric pins with good surface finishes are provided by Crosby and are proven to provide improved fatigue life in actual use. Crosby shackles are fatigue rated as well as load rated. Close pin to hole tolerance has been proven to be critical for good fatigue life, particularly with screw pin shackles.

Fatigue Rated®

**QUENCHED AND TEMPERED**

Quench and tempering assures the uniformity of performance and maximizes the properties of the steel. This means that each shackle meets its rated strength and has required ductility, toughness, impact and fatigue properties. The requirements of your job demand this reliability and consistency. This quench and tempering process develops a tough material that reduces the risk of brittle, catastrophic failure. The shackle bow will deform if overloading occurs, giving warning before ultimate failure.

**THE COMPETITION**

**Ask:** Are their bows and pins quenched and tempered?

**Ask:** If not, are they willing to accept the increased risk of inconsistency?

**Ask:** If not, why are they willing to accept inferior impact, toughness, and product deformation?

**Ask:** Why do many manufacturers not recommend non-heat-treated shackles for overhead lifting?

**Ask:** Why do some recommend Quench and Tempering for alloy but not carbon grades?

Many normalize the shackle bows. As a result, desired properties are not achieved. A few even provide bows in an "as-forged" condition, resulting in the possibility of brittle failure.

Crosby®

All Crosby shackle bows and pins are quenched and tempered, which enhances their performance under cold temperatures and adverse field conditions. Crosby's Quenched and Tempered carbon shackles are recommended for all critical applications including overhead lifting. Alloy shackles are recommended when specific dimensional requirements dictate a size that require higher working load limits. Crosby's Quenched and Tempered shackles provide the tensile strength, ductility, impact and fatigue properties that are essential if they are to perform time after time in adverse conditions. These properties assure that the inspection criteria set forth by ANSI will effectively monitor the ability of the shackles to continue in service.

"QT"  
QUENCHED & TEMPERED**IDENTIFICATION AND APPLICATION INFORMATION**

The proper application of shackles requires that the correct type and size of shackle be used. The shackle's working load limit, its size, a traceability code and the manufacturer's name should be clearly and boldly marked in the bow. Traceability of the material chemistry and properties is essential for total confidence in the product. Material chemistry should be independently verified prior to manufacturing.

**THE COMPETITION**

**Ask:** Do they have an active traceability system used in manufacturing?

**Ask:** Is the material chemistry independently verified?

**Ask:** What training support is provided?

Crosby®

Crosby forges "Crosby" or "CG", the Working Load Limit, and the Product Identification Code (PIC) into each bow and "Crosby" or "CG", and the Product Identification Code (PIC) into each pin of its full line of screw pin, round pin, and bolt type anchor and chain shackles. Seminars conducted by Crosby provide training on the proper use of shackles. Crosby training packets, supplied free to attendees of Crosby seminars, provide training materials needed to explain the proper use of shackles.

QUIC-CHECK®



\* G-2160 Wide Body Shackles are metric rated at 5 to 1. G-2140 Shackles, 200 ton and above, are rated at 4 to 1 in short tons.

**Remember: "When buying Crosby, you're buying more than product, you're buying Quality."**



- **Charpy impact properties:** Crosby's Quenched and Tempered shackles have enhanced impact properties for greater toughness at all temperatures. If requested at the time of order, Crosby can provide Charpy impact properties.
- **Fatigue properties:** Fatigue properties are available for 1/3 to 55 metric ton shackles. These Crosby shackles are fatigue rated to 20,000 cycles at 1-1/2 times the Working Load Limit.
- **Ductility properties:** Typical ductility properties are available for all sizes upon special request.
- **Hardness levels and material tensile strengths:** Typical values are available for all sizes of shackles, and actual values can be furnished if requested at the time of order.
- **Proof Testing:** If requested at the time of order, shackles can be proof tested with certificates.
- **Mag Certification:** If requested at the time of order, shackles can be Mag inspected with certificates.
- **Certification:** Certification to world class standards is available upon special request at the time of order; American Bureau of Shipping, Lloyds Register of Shipping, Det Norske Veritas, American Petroleum Institute, RINA, Nuclear Regulatory Commission, and several other worldwide standards.
- **Applications:** **Round Pin Shackles** can be used in tie down, towing, suspension or lifting applications where the load is strictly applied in-line. **Screw Pin Shackles** can be used in any application where a round pin shackle is used. In addition, screw pin shackles can be used for applications involving side-loading circumstances. Reduced working load limits are required for side-loading applications. **Bolt-Type Shackles** can be used in any application where round pin or screw pin shackles are used. In addition, they are recommended for permanent or long-term installations and where the load may slide on the shackle pin causing the pin to rotate.
- **Material analysis:** Crosby can provide certified material (mill) analysis for each production lot, traceable by the Product Identification Code (PIC). Crosby, through its own laboratory, verifies the analysis of each heat of steel. Crosby purchases only **special bar** forging quality steel with specific cleanliness requirements and guaranteed hardenability.
- **Field inspection:** Written instructions for visual, magnaflux, and dye penetrant inspection of shackles are available from Crosby. In addition, acceptance criteria and repair procedures for shackles are available.
- **QUIC-CHECK®:** Shackles incorporate two marking indicators forged into the shackle bow at 45° angles from vertical. These are utilized to quickly check the approximate angle of a two-legged hitch or check the angle of a single leg hitch. If the load is off vertical or side loaded a reduction in the working load limit of the shackle is required.

### G-209

*Screw pin anchor shackles meet the performance requirements of Federal Specification RR-C-271G, Type IVA, Grade A, Class 2, except for those provisions required of the contractor.*



### G-213

*Round pin anchor shackles meet the performance requirements of Federal Specification RR-C-271G, Type IVA, Grade A, Class 1, except for those provisions required of the contractor.*



### G-2130

*Bolt-type anchor shackles meet the performance requirements of Federal Specification RR-C-271G, Type IVA, Grade A, Class 3, except for those provisions required of the contractor.*



### G-210

*Screw pin chain shackles meet the performance requirements of Federal Specification RR-C-271G, Type IVB, Grade A, Class 2, except for those provisions required of the contractor.*



### G-215

*Round pin chain shackles meet the performance requirements of Federal Specification RR-C-271G, Type IVB, Grade A, Class 1, except for those provisions required of the contractor.*



### G-2150

*Bolt-type chain shackles meet the performance requirements of Federal Specification RR-C-271G, Type IVB, Grade A, Class 3, except for those provisions required of the contractor.*

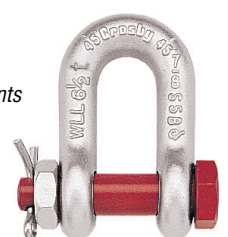



### G-213/S-213

G-213 Round pin anchor shackles meet the performance requirements of Federal Specification RR-C-271G, Type IVA, Grade A, Class 1, except for those provisions required of the contractor. For additional information, see page 452.



### G-215/S-215

G-215 Round pin chain shackles meet the performance requirements of Federal Specification RR-C-271G Type IVB, Grade A, Class 1, except for those provisions required of the contractor. For additional information, see page 476.

- Capacities 1/2 through 35 metric tons.
- Forged - Quenched and Tempered, with alloy pins.
- Working Load Limit permanently shown on every shackle.
- Hot Dip galvanized or Self Colored.
- Sizes 3/8 inch and below are mechanically galvanized.
- Fatigue rated.
- Shackles 25t and larger are **RFID EQUIPPED**.
- Shackles can be furnished proof tested with certificates to designated standards, such as ABS, DNV, Lloyds, or other certification. Charges for proof testing and certification available when requested at the time of order.
- Shackles are Quenched and Tempered and can meet DNV impact requirements of 42 Joules (31 ft•lbf) at -20° C (-4° F).
- Look for the Red Pin® . . . the mark of genuine Crosby quality.



**SEE APPLICATION INFORMATION**

On Page 92 of the General Catalog  
Para Español: [www.thecrosbygroup.com](http://www.thecrosbygroup.com)

## G-213 / S-213 Round Pin Anchor Shackles

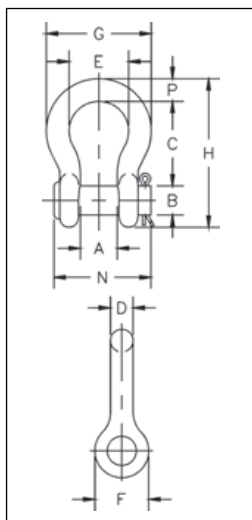

Nominal Size (in)	Working Load Limit (t)*	Stock No.		Weight Each (lb)	Dimensions (in)										Tolerance +/-	
		G-213	S-213		A	B	C	D	E	F	G	H	N	P	C	A
1/4	1/2	1018017	1018026	.13	.47	.31	1.13	.25	.78	.61	1.28	1.84	1.34	.25	.06	.06
5/16	3/4	1018035	1018044	.18	.53	.38	1.22	.31	.84	.75	1.47	2.09	1.59	.31	.06	.06
3/8	1	1018053	1018062	.29	.66	.44	1.44	.38	1.03	.91	1.78	2.49	1.86	.38	.13	.06
7/16	1-1/2	1018071	1018080	.38	.75	.50	1.69	.44	1.16	1.06	2.03	2.91	2.13	.44	.13	.06
1/2	2	1018099	1018106	.71	.81	.63	1.88	.50	1.31	1.19	2.31	3.28	2.38	.50	.13	.06
5/8	3-1/4	1018115	1018124	1.50	1.06	.75	2.38	.63	1.69	1.50	2.94	4.19	2.91	.69	.13	.06
3/4	4-3/4	1018133	1018142	2.32	1.25	.88	2.81	.75	2.00	1.81	3.50	4.97	3.44	.81	.25	.06
7/8	6-1/2	1018151	1018160	3.49	1.44	1.00	3.31	.88	2.28	2.09	4.03	5.83	4.81	.97	.25	.06
1	8-1/2	1018179	1018188	5.00	1.69	1.13	3.75	1.00	2.69	2.38	4.69	6.56	4.53	1.06	.25	.06
1-1/8	9-1/2	1018197	1018204	6.97	1.81	1.25	4.25	1.13	2.91	2.69	5.16	7.47	5.13	1.25	.25	.06
1-1/4	12	1018213	1018222	9.75	2.03	1.38	4.69	1.29	3.25	3.00	5.75	8.25	5.50	1.38	.25	.06
1-3/8	13-1/2	1018231	1018240	13.25	2.25	1.50	5.25	1.42	3.63	3.31	6.38	9.16	6.13	1.50	.25	.13
1-1/2	17	1018259	1018268	17.25	2.38	1.63	5.75	1.54	3.88	3.63	6.88	10.00	6.50	1.62	.25	.13
1-3/4	25	1018277	1018286	29.46	2.88	2.00	7.00	1.84	5.00	4.19	8.86	12.34	7.75	2.25	.25	.13
2	35	1018295	1018302	45.75	3.25	2.25	7.75	2.08	5.75	4.81	9.97	13.68	8.75	2.40	.25	.13

\* NOTE: Maximum Proof Load is 2 times the Working Load Limit. Minimum Ultimate Strength is 6 times the Working Load Limit. DO NOT SIDE LOAD ROUND PIN SHACKLES.

## G-215 / S-215 Round Pin Chain Shackles

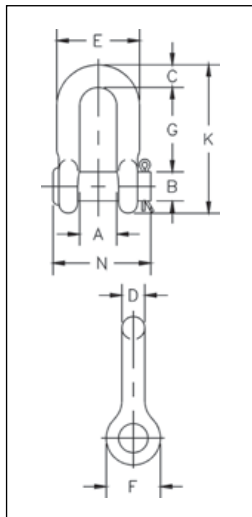

Nominal Size (in)	Working Load Limit (t)*	Stock No.		Weight Each (lb)	Dimensions (in)										Tolerance +/-	
		G-215	S-215		A	B	C	D	E	F	G	K	N	G	A	
1/4	1/2	1018810	1018829	.10	.47	.31	.25	.25	.97	.62	.91	1.59	1.34	.06	.06	
5/16	3/4	1018838	1018847	.18	.53	.38	.31	.31	1.15	.75	1.07	1.91	1.63	.06	.06	
3/8	1	1018856	1018865	.25	.66	.44	.38	.38	1.42	.92	1.28	2.31	1.86	.13	.06	
7/16	1-1/2	1018874	1018883	.40	.75	.50	.44	.44	1.63	1.06	1.48	2.67	2.13	.13	.06	
1/2	2	1018892	1018909	.50	.81	.63	.50	.50	1.81	1.18	1.66	3.03	2.38	.13	.06	
5/8	3-1/4	1018918	1018927	1.21	1.06	.75	.63	.63	2.32	1.50	2.04	3.76	2.91	.13	.06	
3/4	4-3/4	1018936	1018945	2.00	1.25	.88	.81	.75	2.75	1.81	2.40	4.53	3.44	.25	.06	
7/8	6-1/2	1018954	1018963	3.28	1.44	1.00	.97	.88	3.20	2.10	2.86	5.33	3.81	.25	.06	
1	8-1/2	1018972	1018981	4.75	1.69	1.13	1.00	1.00	3.69	2.38	3.24	5.94	4.53	.25	.06	
1-1/8	9-1/2	1018990	1019007	6.30	1.81	1.25	1.25	1.13	4.07	2.68	3.61	6.78	5.13	.25	.06	
1-1/4	12	1019016	1019025	9.00	2.03	1.38	1.38	1.25	4.53	3.00	3.97	7.50	5.50	.25	.13	
1-3/8	13-1/2	1019034	1019043	12.00	2.25	1.50	1.50	1.38	5.01	3.31	4.43	8.28	6.13	.25	.13	
1-1/2	17	1019052	1019061	16.15	2.38	1.63	1.62	1.50	5.38	3.62	4.87	9.05	6.50	.25	.13	
1-3/4	25	1019070	1019089	29.96	2.88	2.00	2.12	1.75	6.38	4.19	5.82	10.97	7.75	.25	.13	
2	35	1019098	1019105	43.25	3.25	2.25	2.36	2.10	7.25	5.00	6.82	12.74	8.75	.25	.13	

\* NOTE: Maximum Proof Load is 2 times the Working Load Limit. Minimum Ultimate Strength is 6 times the Working Load Limit. DO NOT SIDE LOAD ROUND PIN SHACKLES.



# Crosby® Screw Pin Shackles



## G-209/S-209

G-209 Screw pin anchor shackles meet the performance requirements of Federal Specification RR-C-271G Type IVA, Grade A, Class 2, except for those provisions required of the contractor. For additional information, see page 452.

- Capacities 1/3 thru 55 metric tons, grade 6.
- Forged - Quenched and Tempered, with alloy pins.
- Working Load Limit and grade "6" permanently shown on every shackle.
- Hot Dip galvanized or self colored.
- Sizes 3/8 inch and below are mechanically galvanized.
- Fatigue rated.
- Shackles 25t and larger are RFID EQUIPPED.
- Shackles can be furnished proof tested with certificates to designated standards, such as ABS, DNV, Lloyds, or other certification. Proof testing and certification available when requested at the time of order, charges will apply.
- Approved for use at -40° C (-40° F) to 204° C (400° F).
- All 209 and 210 shackles can meet charpy requirements of 42 Joules (31 ft•lbf) avg. at -20° C (-4° F) upon special request.
- Meets or exceeds all requirements of ASME B30.26.
- Type Approval certification in accordance with ABS 2016 Steel Vessel Rules and ABS Guide for Certification of Lifting Appliances available. Certificates available when requested at time of order and may include additional charges.
- Look for the Red Pin® . . . the mark of genuine Crosby quality.



## G-210/S-210

G-210 Screw pin anchor shackles meet the performance requirements of Federal Specification RR-C-271G Type IVB, Grade A, Class 2, except for those provisions required of the contractor. For additional information, see page 452.

Shackles

Load Rated Fatigue Rated



QUIC-CHECK®



MAXTOUGH®



**SEE APPLICATION INFORMATION**  
On Page 92 of the General Catalog  
Para Español: www.thecrosbygroup.com

## G-209 / S-209 Screw Pin Anchor Shackles

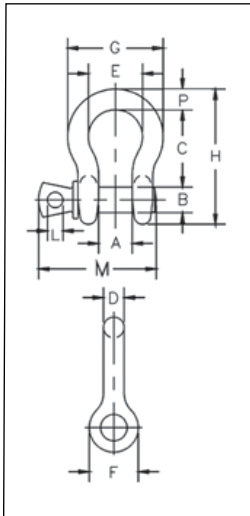

Nominal Size (in)	Working Load Limit (t)*	Stock No.		Weight Each (lb)	Dimensions (in)											Tolerance +/-	
		G-209	S-209		A	B	C	D	E	F	G	H	L	M	P	C	A
3/16	1/3	1018357	-	.06	.38	.25	.88	.19	.60	.56	.98	1.47	.16	1.14	.19	.06	.06
1/4	1/2	1018375	1018384	.10	.47	.31	1.13	.25	.78	.61	1.28	1.84	.19	1.43	.25	.06	.06
5/16	3/4	1018393	1018400	.18	.53	.38	1.22	.31	.84	.75	1.47	2.09	.22	1.71	.31	.06	.06
3/8	1	1018419	1018428	.31	.66	.44	1.44	.38	1.03	.91	1.78	2.49	.25	2.02	.38	.13	.06
7/16	1-1/2	1018437	1018446	.38	.75	.50	1.69	.44	1.16	1.06	2.03	2.91	.31	2.37	.44	.13	.06
1/2	2	1018455	1018464	.72	.81	.63	1.88	.50	1.31	1.19	2.31	3.28	.38	2.69	.50	.13	.06
5/8	3-1/4	1018473	1018482	1.37	1.06	.75	2.38	.63	1.69	1.50	2.94	4.19	.44	3.34	.69	.13	.06
3/4	4-3/4	1018491	1018507	2.35	1.25	.88	2.81	.75	2.00	1.81	3.50	4.97	.50	3.97	.81	.25	.06
7/8	6-1/2	1018516	1018525	3.62	1.44	1.00	3.31	.88	2.28	2.09	4.03	5.83	.50	4.50	.97	.25	.06
1	8-1/2	1018534	1018543	5.03	1.69	1.13	3.75	1.00	2.69	2.38	4.69	6.56	.56	5.13	1.06	.25	.06
1-1/8	9-1/2	1018552	1018561	7.41	1.81	1.25	4.25	1.16	2.91	2.69	5.16	7.47	.63	5.71	1.25	.25	.06
1-1/4	12	1018570	1018589	9.50	2.03	1.38	4.69	1.29	3.25	3.00	5.75	8.25	.69	6.25	1.38	.25	.06
1-3/8	13-1/2	1018598	1018605	13.53	2.25	1.50	5.25	1.42	3.63	3.31	6.38	9.16	.75	6.83	1.50	.25	.13
1-1/2	17	1018614	1018623	17.20	2.38	1.63	5.75	1.54	3.88	3.63	6.88	10.00	.81	7.33	1.62	.25	.13
1-3/4	25	1018632	1018641	27.78	2.88	2.00	7.00	1.84	5.00	4.19	8.86	12.34	1.00	9.06	2.25	.25	.13
2	35	1018650	1018669	45.00	3.25	2.25	7.75	2.08	5.75	4.81	9.97	13.68	1.22	10.35	2.40	.25	.13
2-1/2	55	1018678	1018687	85.75	4.13	2.75	10.50	2.71	7.25	5.69	12.87	17.84	1.38	13.00	3.13	.25	.25

## G-210 / S-210 Screw Pin Chain Shackles

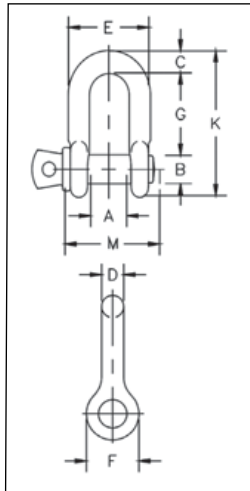

Nominal Size (in)	Working Load Limit (t)*	Stock No.		Weight Each (lb)	Dimensions (in)											Tolerance +/-	
		G-210	S-210		A	B	C	D	E	F	G	K	L	M	G	A	
1/4	1/2	1019150	1019169	.11	.47	.31	.25	.25	.97	.62	.97	1.59	.19	1.43	.06	.06	
5/16	3/4	1019178	1019187	.17	.53	.38	.31	.31	1.15	.75	1.07	1.91	.22	1.71	.06	.06	
3/8	1	1019196	1019203	.28	.66	.44	.38	.38	1.42	.92	1.28	2.31	.25	2.02	.13	.06	
7/16	1-1/2	1019212	1019221	.43	.75	.50	.44	.44	1.63	1.06	1.48	2.67	.31	2.37	.13	.06	
1/2	2	1019230	1019249	.59	.81	.63	.50	.50	1.81	1.18	1.66	3.03	.38	2.69	.13	.06	
5/8	3-1/4	1019258	1019267	1.25	1.06	.75	.63	.63	2.32	1.50	2.04	3.76	.44	3.34	.13	.06	
3/4	4-3/4	1019276	1019285	2.63	1.25	.88	.81	.75	2.75	1.81	2.40	4.53	.50	3.97	.25	.06	
7/8	6-1/2	1019294	1019301	3.16	1.44	1.00	.97	.88	3.20	2.10	2.86	5.33	.50	4.50	.25	.06	
1	8-1/2	1019310	1019329	4.75	1.69	1.13	1.00	1.00	3.69	2.38	3.24	5.94	.56	5.13	.25	.06	
1-1/8	9-1/2	1019338	1019347	6.75	1.81	1.25	1.25	1.13	4.07	2.69	3.61	6.78	.63	5.71	.25	.06	
1-1/4	12	1019356	1019365	9.06	2.03	1.38	1.38	1.25	4.53	3.00	3.97	7.50	.69	6.25	.25	.06	
1-3/8	13-1/2	1019374	1019383	11.63	2.25	1.50	1.50	1.38	5.01	3.31	4.43	8.28	.75	6.53	.25	.13	
1-1/2	17	1019392	1019409	15.95	2.38	1.63	1.62	1.50	5.38	3.62	4.87	9.05	.81	7.33	.25	.13	
1-3/4	25	1019418	1019427	26.75	2.88	2.00	2.12	1.75	6.38	4.19	5.78	10.97	1.00	9.06	.25	.13	
2	35	1019436	1019445	42.31	3.25	2.25	2.36	2.10	7.25	5.00	6.77	12.74	1.13	10.35	.25	.13	
2-1/2	55	1019454	1019463	71.75	4.12	2.75	2.63	2.63	9.38	5.68	8.07	14.85	1.38	13.00	.25	.25	

\* NOTE: Maximum Proof Load is 2 times the Working Load Limit. Minimum Ultimate Strength is 6 times the Working Load Limit. For Working Load Limit reduction due to side loading applications, see page 94.



# Crosby® Alloy Screw Pin Shackles



**G-209A**

Screw pin anchor shackles meet the performance requirements of Federal Specification RR-C 271G, Type IVA, Grade B, Class 2, except for those provisions required of the contractor. For additional information, see page 452.

- Capacities 2 thru 21 metric tons. Meets performance requirements of Grade 8 shackles.
- Forged Alloy Steel – Quenched and Tempered, with alloy pins.
- Working Load Limit permanently shown on every shackle.
- Hot Dip Galvanized.
- Sizes 3/8 inch and below are mechanically galvanized.
- Shackles can be furnished proof tested with certificates to designated standards, such as ABS, DNV, Lloyds, or other certification. Charges for proof testing and certification available when requested at the time of order.
- Approved for use at -40° C (-40° F) to 204° C (400° F).
- Meets or exceeds all requirements of ASME B30.26 including identification, ductility, design factor, proof load and temperature requirements. Importantly, these shackles meet other critical performance requirements including impact properties and material traceability, not addressed by ASME B30.26.

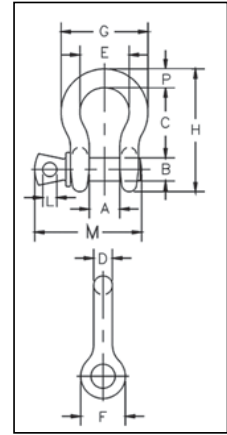

**SEE APPLICATION INFORMATION**

On Page 92 of the General Catalog  
Para Español: www.thecrosbygroup.com

## G-209A Alloy Screw Pin Shackles

Nominal Size (in)	Working Load Limit (t)*	G-209A Stock No.	Weight Each (lb)	Dimensions (in)												Tolerance +/-	
				A	B	C	D	E	F	G	H	L	M	P	C	A	
3/8	2	1017450	.31	.66	.44	1.44	.38	1.03	.91	1.78	2.49	.25	2.03	.38	.13	.06	
7/16	2-2/3	1017472	.38	.75	.50	1.69	.44	1.16	1.06	2.03	2.91	.31	2.38	.44	.13	.06	
1/2	3-1/3	1017494	.63	.81	.63	1.88	.50	1.31	1.19	2.31	3.28	.38	2.69	.50	.13	.06	
5/8	5	1017516	1.38	1.06	.75	2.38	.63	1.69	1.50	2.94	4.19	.44	3.34	.69	.13	.06	
3/4	7	1017538	2.35	1.25	.88	2.81	.75	2.00	1.81	3.50	4.97	.50	3.97	.81	.25	.06	
7/8	9-1/2	1017560	3.61	1.44	1.00	3.31	.88	2.28	2.09	4.03	5.83	.50	4.50	.97	.25	.06	
1	12-1/2	1017582	5.32	1.69	1.13	3.75	1.00	2.69	2.38	4.69	6.56	.56	5.07	1.06	.25	.06	
1-1/8	15	1017604	7.25	1.81	1.25	4.25	1.16	2.91	2.69	5.16	7.47	.63	5.59	1.25	.25	.06	
1-1/4	18	1017626	9.88	2.03	1.38	4.69	1.29	3.25	3.00	5.75	8.25	.69	6.16	1.38	.25	.06	
1-3/8	21	1017648	13.25	2.25	1.50	5.25	1.42	3.63	3.31	6.38	9.16	.75	6.84	1.50	.25	.13	

\* Maximum Proof Load is 2 times the Working Load Limit (metric tons) and 2.2 times the Working Load Limit (short tons). Minimum Ultimate Strength is 4.5 times the Working Load Limit for metric tonnes, and 5 times the Working Load Limit for short tons. For Working Load Limit reduction due to side loading applications, see page 94.



**G-2169**



**S-2169**

- Capacities of 7, 12.5 and 18 metric tons.
- Quenched and Tempered for maximum strength.
- Forged Alloy Steel.
- Available in galvanized and self colored finish
- Individually proof tested and magnetic particle inspected. Crosby certification available at time of order.
- Meets or exceeds all requirements of ASME B30.26 including identification, ductility, design factor, proof load and temperature requirements. Importantly, these shackles meet other critical performance requirements including fatigue life, impact properties and material traceability, not addressed by ASME B30.26.
- Look for the Red Pin® . . . the mark of genuine Crosby quality.

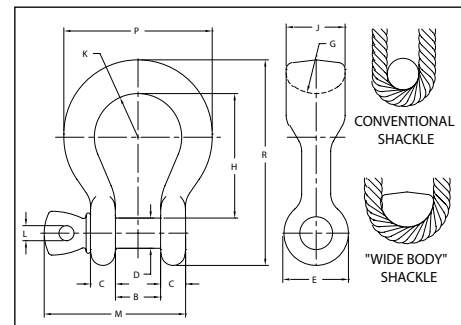

**SEE APPLICATION INFORMATION**

On Page 92 of the General Catalog  
Para Español: www.thecrosbygroup.com

## G-2169 / S-2169 Alloy Screw Pin “Wide Body” Shackles

Working Load Limit (t)*	G-2169 Stock No.	S-2169 Stock No.	Weight Each (lb)	Dimensions (in)												
				B +/- .25	C	D +/- .02	E	G	H	J	K	L	M	P	R	
7	1021655	1021664	3.5	1.25	.69	.88	1.82	1.25	3.56	1.60	1.25	.50	3.97	4.10	5.87	
12.5	1021673	1021682	8.8	1.69	.92	1.13	2.38	1.37	4.63	2.13	1.63	.56	5.13	5.51	7.63	
18	1021691	1021699	13	2.03	1.16	1.38	2.69	1.50	5.81	2.50	2.00	.69	6.25	6.76	9.38	

\* Ultimate Load is 5 times the Working Load Limit. Proof Load is 2 times the Working Load Limit.

# Crosby® Bolt Type Shackles



## G-2130 / S-2130

Bolt Type Anchor shackles with thin head bolt - nut with cotter pin. Meets the performance requirements of Federal Specification RR-C 271G, Type IVA, Grade A, Class 3, except for those provisions required of the contractor. For additional information, see page 452.

- Capacities 1/3 thru 150 metric tons, grade 6.
- Working Load Limit and grade "6" permanently shown on every shackle.
- Forged – Quenched and Tempered, with alloy bolts.
- Hot Dip galvanized or self colored. (85, 120, and 150 metric ton shackles are all hot dip galvanized bows and the bolts are Dimetcoated® and painted red)
- Sizes 3/8 and below are mechanically galvanized.
- Fatigue rated (1/3t - 55t).
- Shackles 25t and larger are **RFID EQUIPPED**.
- Approved for use at -40° C (-40° F) to 204° C (400° F).
- Meets or exceeds all requirements of ASME B30.26.
- Shackles 85 metric tons and larger are individually proof tested to 2.0 times the working load limit.
- Type Approval certification in accordance with ABS 2016 Steel Vessel Rules ABS Guide for Certification of Lifting Appliances available. Certificates available when requested at time of order and may include additional charges.
- 3.1 Certification as standard available for charpy and statistical proof test from 3.25t up to 25 tons to DNV2.7-1 and EN13889.
- Crosby 3.25t through 25t G2130OC anchor shackles are type approved to DNV Certification Notes 2.7-1- Offshore Containers. These Crosby shackles are statistical proof and impact tested to 42 Joules (31 ft•lbf) min. avg. at -20° C (-4° F). The tests are conducted by Crosby and 3.1 test certification is available upon request. Refer to page 87 for Crosby COLD TUFF® shackles that meet the additional requirements of DNV rules for certification of lifting applications - Loose Gear.
- All other 2130 shackles can meet charpy requirements of 42 Joules (31 ft•lbf) avg at -20° C (-4° F) when requested at time of order.
- Look for the Red Pin® . . . the mark of genuine Crosby quality.

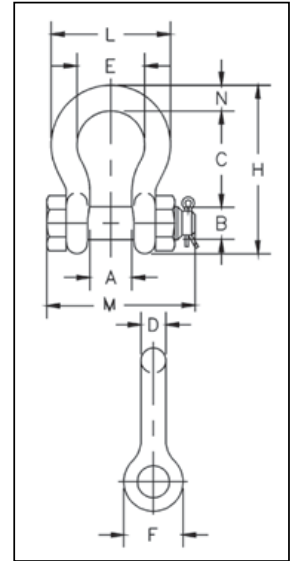

Shackles



**SEE APPLICATION INFORMATION**  
On Page 92 of the General Catalog  
Para Español: [www.thecrosbygroup.com](http://www.thecrosbygroup.com)

## G-2130 / S-2130 Bolt Type Anchor Shackles

Nominal Size (in)	Working Load Limit (t)*	Stock No.			Weight Each (lb)	Dimensions (in)											Tolerance +/-	
		G-2130	S-2130	G-2130OC		A	B	C	D	E	F	H	L	M	N	C	A	
3/16	1/3 ‡	1019464	-	-	.06	.38	.25	.88	.19	.60	.56	1.47	.98	1.29	.19	.06	.06	
1/4	1/2	1019466	-	-	.11	.47	.31	1.13	.25	.78	.61	1.84	1.28	1.56	.25	.06	.06	
5/16	3/4	1019468	-	-	.22	.53	.38	1.22	.31	.84	.75	2.09	1.47	1.82	.31	.06	.06	
3/8	1	1019470	-	-	.33	.66	.44	1.44	.38	1.03	.91	2.49	1.78	2.17	.38	.13	.06	
7/16	1-1/2	1019471	-	-	.49	.75	.50	1.69	.44	1.16	1.06	2.91	2.03	2.51	.44	.13	.06	
1/2	2	1019472	1019481	-	.79	.81	.64	1.88	.50	1.31	1.19	3.28	2.31	2.80	.50	.13	.06	
5/8	3-1/4	1019490	1019506	1262013	1.68	1.06	.77	2.38	.63	1.69	1.50	4.19	2.94	3.56	.69	.13	.06	
3/4	4-3/4	1019515	1019524	1262022	2.72	1.25	.89	2.81	.75	2.00	1.81	4.97	3.50	4.15	.81	.25	.06	
7/8	6-1/2	1019533	1019542	1262031	3.95	1.44	1.02	3.31	.88	2.28	2.09	5.83	4.03	4.82	.97	.25	.06	
1	8-1/2	1019551	1019560	1262040	5.66	1.69	1.15	3.75	1.00	2.69	2.38	6.56	4.69	5.39	1.06	.25	.06	
1-1/8	9-1/2	1019579	1019588	1262059	8.27	1.81	1.25	4.25	1.13	2.91	2.69	7.47	5.16	5.90	1.25	.25	.06	
1-1/4	12	1019597	1019604	1262068	11.71	2.03	1.40	4.69	1.29	3.25	3.00	8.25	5.75	6.69	1.38	.25	.06	
1-3/8	13-1/2	1019613	1019622	1262077	15.83	2.25	1.53	5.25	1.42	3.63	3.31	9.16	6.38	7.21	1.50	.25	.13	
1-1/2	17	1019631	1019640	1262086	19.00	2.38	1.66	5.75	1.53	3.88	3.63	10.00	6.88	7.73	1.62	.25	.13	
1-3/4	25	1019659	1019668	1262095	33.91	2.88	2.04	7.00	1.84	5.00	4.19	12.34	8.80	9.68	2.25	.25	.13	
2	35	1019677	1019686	-	52.25	3.25	2.30	7.75	2.08	5.75	4.81	13.68	10.15	10.81	2.40	.25	.13	
2-1/2	55	1019695	1019702	-	98.25	4.13	2.80	10.50	2.71	7.25	5.69	17.90	12.75	13.58	3.13	.25	.25	
3	† 85	1019711	-	-	154.00	5.00	3.30	13.00	3.12	7.88	6.50	21.50	14.62	15.13	3.62	.25	.25	
3-1/2	† 120 ‡	1019739	-	-	265.00	5.25	3.76	14.63	3.62	9.00	8.00	24.88	17.02	17.00	4.38	.25	.25	
4	† 150 ‡	1019757	-	-	338.00	5.50	4.26	14.50	4.00	10.00	9.00	25.68	18.00	17.75	4.56	.25	.25	

\* NOTE: Maximum Proof Load is 2 times the Working Load Limit. Minimum Ultimate Strength is 6 times the Working Load Limit. For Working Load Limit reduction due to side loading applications, see page 94. † Individually Proof Tested with certification. ‡ Furnished in Anchor style only and furnished with eyebolts for handling.



**G-2150 / S-2150**

Bolt Type chain shackles with thin hex head bolt - nut with cotter pin. Meets the performance requirements of Federal Specification RR-C 271G, Type IVB, Grade A, Class 3, except for those provisions required of the contractor. For additional information, see page 452.

- Capacities 1/2 thru 85 metric tons, grade 6.
- Working Load Limit and grade "6" permanently shown on every shackle.
- Forged — Quenched and Tempered, with alloy pins.
- Hot Dip galvanized or self colored. (85, 120, and 150-metric ton shackles are all hot dip galvanized bows and the bolts are Dimetcoated® and painted red).
- Sizes 3/8 inch and below are mechanically galvanized.
- Fatigue rated (1/2t - 55t).
- Shackles 25t and larger are **RFID EQUIPPED**.
- Approved for use at -40° C (-40 degrees F) to 204° C (400° F).
- Meets or exceeds all requirements of ASME B30.26.
- Sizes 1/2 - 25t meet the performance requirements of EN13889:2003.
- Shackles 55 metric tons and smaller can be furnished proof tested with certificate to designated standards, such as ABS, DNV, Lloyds, or other certification where requested at time of order.
- Type Approval certification in accordance with ABS 2016 Steel Vessel Rules and 2016 ABS Guide for Certification of Lifting Appliance. Certificates available when requested at time of order and may include additional charges.
- All 2150 shackles can meet charpy requirements of 42 Joules (31 ft•lb) avg at -20° C (-4° F) upon special request.
- Look for the Red Pin® . . . the mark of genuine Crosby quality.

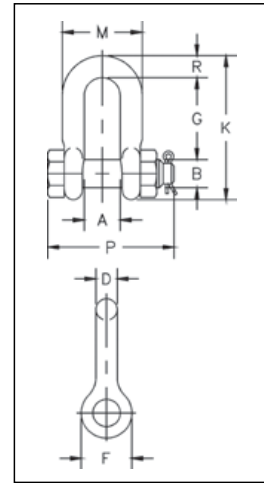

**SEE APPLICATION INFORMATION**  
 On Page 92 of the General Catalog  
 Para Español: www.thecrosbygroup.com

**G-2150 / S-2150 Bolt Type Chain Shackles**

Nominal Size (in)	Working Load Limit (t)*	Stock No.		Weight Each (lb)	Dimensions (in)										Tolerance +/-	
		G-2150	S-2150		A	B	D	F	G	K	M	P	R	G	A	
1/4	1/2	1019768	-	.13	.47	.31	.25	.62	.91	1.59	.97	1.56	.25	.06	.06	
5/16	3/4	1019770	-	.23	.53	.38	.31	.75	1.07	1.91	1.15	1.82	.31	.06	.06	
3/8	1	1019772	-	.33	.66	.44	.38	.92	1.28	2.31	1.42	2.17	.38	.13	.06	
7/16	1-1/2	1019774	-	.49	.75	.50	.44	1.06	1.48	2.67	1.63	2.51	.44	.13	.06	
1/2	2	1019775	1019784	.75	.81	.64	.50	1.18	1.66	3.03	1.81	2.80	.50	.13	.06	
5/8	3-1/4	1019793	1019800	1.47	1.06	.77	.63	1.50	2.04	3.76	2.32	3.56	.63	.13	.06	
3/4	4-3/4	1019819	1019828	2.52	1.25	.89	.75	1.81	2.40	4.53	2.75	4.15	.81	.25	.06	
7/8	6-1/2	1019837	1019846	3.85	1.44	1.02	.88	2.10	2.86	5.33	3.20	4.82	.97	.25	.06	
1	8-1/2	1019855	1019864	5.55	1.69	1.15	1.00	2.38	3.24	5.94	3.69	5.39	1.00	.25	.06	
1-1/8	9-1/2	1019873	1019882	7.60	1.81	1.25	1.13	2.68	3.61	6.78	4.07	5.90	1.25	.25	.06	
1-1/4	12	1019891	1019908	10.81	2.03	1.40	1.25	3.00	3.97	7.50	4.53	6.69	1.38	.25	.06	
1-3/8	13-1/2	1019917	1019926	13.75	2.25	1.53	1.38	3.31	4.43	8.28	5.01	7.21	1.50	.25	.13	
1-1/2	17	1019935	1019944	18.50	2.38	1.66	1.50	3.62	4.87	9.05	5.38	7.73	1.62	.25	.13	
1-3/4	25	1019953	1019962	31.40	2.88	2.04	1.75	4.19	5.82	10.97	6.38	9.33	2.12	.25	.13	
2	35	1019971	1019980	46.75	3.25	2.30	2.10	5.00	6.82	12.74	7.25	10.41	2.36	.25	.13	
2-1/2	55	1019999	1020004	85.00	4.12	2.80	2.63	5.68	8.07	14.85	9.38	13.58	2.63	.25	.25	
3	† 85	1020013	-	124.25	5.00	3.25	3.00	6.50	8.56	16.87	11.00	15.13	3.50	.25	.25	

\* NOTE: Maximum Proof Load is 2 times the Working Load Limit. Minimum Ultimate Strength is 6 times the Working Load Limit. For Working Load Limit reduction due to side loading applications, see page 94. † Individually Proof Tested with certification



# Crosby® Bolt Type Shackles



**G-2130A**

Bolt Type Anchor shackles with thin head bolt – nut with cotter pin. Meets the performance requirements of Federal Specification R-C-271G, Type IVA, Grade B, Class 3, except for those provisions required of the contractor. For additional information, see page 452.

- Capacities 2 to 17 metric tons.
- Meets or exceeds all requirements of Grade 8 shackles.
- Working Load Limit permanently shown on every shackle.
- Forged Alloy Steel – Quenched and Tempered, with bow and bolt.
- Hot Dip galvanized.
- Shackles can be **RFID EQUIPPED**.
- Meets or exceeds all requirements of ASME B30.26 including identification, ductility, design factor, proof load and temperature requirements. Importantly, G-2130A meet other critical performance requirements including impact properties and material traceability, not addressed by ASME B30.26.
- Shackles can be furnished proof tested with certificates to designated standards, such as ABS, DNV, Lloyds, or other certification when requested at time of order.
- Type Approval and certification in accordance with DNV 2.7-1 O fshore Containers.
- Shackles are Quenched and Tempered and meet DNV impact requirements of 42 Joules (31 ft•lbf) at -40° C (-40° F).

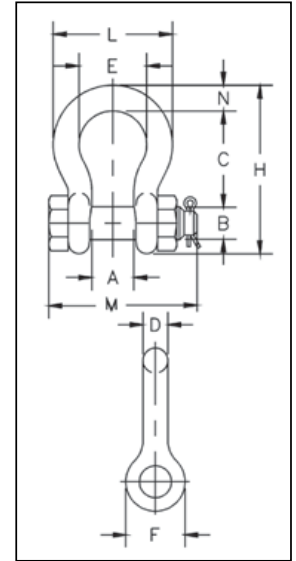

Shackles



**SEE APPLICATION INFORMATION**  
On Page 92 of the General Catalog  
Para Español: [www.thecrosbygroup.com](http://www.thecrosbygroup.com)

## G-2130A Alloy Bolt Bolt Type Shackles Grade 8

Nominal Size (in)	Working Load Limit (t)*	G-2130A Stock No.	Weight Each (lb)	Dimensions (in)										Tolerance +/-	
				A	B	C	D	E	F	H	L	M	N	C	A
1/2	2	1219472	.79	.81	.63	1.88	0.50	1.31	1.19	3.29	2.30	2.80	0.50	0.13	0.06
5/8	3-1/4	1219491	1.37	1.06	.75	2.38	0.63	1.69	1.50	4.18	2.94	3.56	0.69	0.25	0.06
3/4	4-3/4	1219516	2.71	1.25	.88	2.82	0.75	2.01	1.81	4.96	3.51	4.15	0.81	0.25	0.06
7/8	6-1/2	1219534	3.95	1.44	1.00	3.31	0.88	2.29	2.09	5.83	4.02	4.82	0.97	0.25	0.06
1	8-1/2	1219552	5.03	1.69	1.10	3.76	1.00	2.70	2.38	6.58	4.69	5.39	1.06	0.25	0.06
1-1/8	9-1/2	1219578	8.27	1.81	1.25	4.26	1.13	2.92	2.70	7.49	5.16	5.90	1.25	0.25	0.06
1-1/4	12	1219598	11.7	2.03	1.38	4.69	1.25	3.25	2.99	8.27	5.75	6.69	1.38	0.25	0.06
1-3/8	13-1/2	1219614	15.8	2.25	1.50	5.24	1.38	3.62	3.31	9.18	6.38	7.21	1.50	0.25	0.13
1-1/2	17	1219632	19.0	2.38	1.63	5.75	1.50	3.88	3.62	10.0	6.90	7.73	1.62	0.25	0.13

\* NOTE: Maximum Proof Load is 2 times the Working Load Limit. Minimum Ultimate Strength is 8 times the Working Load Limit. For Working Load Limit reduction due to side loading applications, see page 94.



### Testing the Limits

In 2013, Sir Ranulph Fiennes and five colleague set out to test the limits of human endurance and achieve the feat of becoming the first individual to cross the continent of Antarctica in winter. As a proud partner in this endeavor, Crosby provided its full range of COLD TUFF® products, which are specifically manufactured to function in extreme environments such as those encountered throughout the expedition—including temperatures as low as -90° C.





**G-2140 / S-2140**

G-2140 meets the performance requirements of Federal Specification RR-C-271G, Type IVA, Grade B, Class 3, except for those provisions required of the contractor. For additional information, see page 452.

- Quenched and Tempered.
- Alloy bows, Alloy bolts.
- Forged Alloy Steel 2 thru 200 metric tons. Cast Alloy Steel 250 thru 400 metric tons. Meets performance requirements of Grade 8 shackles.
- Working Load Limit is permanently shown on every shackle.
- 30, 40, 55, and 85 metric ton shackle bows are available galvanized or self colored with bolts that are galvanized and painted red.
- Sizes 3/8 inch and below are mechanically galvanized.
- 120, 150, 175 metric ton shackle bows are hot-dip galvanized; bolts are Dimetcoted and painted red.
- 400 metric ton shackle bows are Dimetcoted; bolts are Dimetcoted and painted red.
- Sizes 1-1/2 and larger are **RFID EQUIPPED**.
- Approved for use at -40° C (-40° F) to 204° C (400° F).
- Shackles are Quenched and Tempered and can meet DNV impact requirements of 42 Joules (31 ft•lbf) at -20° C (-4° F).
- All sizes are individually proof tested to 2.0 times the Working Load Limit.
- Refer to page 87 for Crosby COLD TUFF® shackles that meet the additional requirements of DNV rules for certification of lifting applications - Loose Gea .
- Shackles 200 metric tons and larger are provided as follows.
  - Serialized bolt and bow
  - Material certification (chemical)
  - Magnetic particle inspected.
  - Certification must be requested at time of orde .
- Meets or exceeds all requirements of ASME B30.26 including identification, ductility , design factor, proof load and temperature requirements. 2140 shackles meet other critical performance requirements including impact properties and material traceability, not addressed by ASME B30.26.
- Type Approval certification in accordance with ABS 2016 Steel Vessel Rules and 2016 ABS Guide for Certification of Liftin Appliances. Certificates available when requested at time of order and ma include additional charges.
- Look for the Red Pin® . . . the mark of genuine Crosby quality.

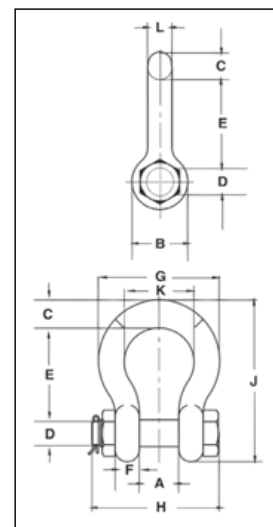

**SEE APPLICATION INFORMATION**

On Page 92 of the General Catalog  
Para Español: [www.thecrosbygroup.com](http://www.thecrosbygroup.com)

## G-2140 / S-2140 Crosby® Alloy Bolt Type Anchor Shackles

Nominal Shackle Size (in)	Working Load Limit (t)*	Stock No.			Weight Each (lb)	Dimensions (in)														Tolerance + / -	
		G-2140	S-2140	G-2140OC		A	B	C	D +/- .02	E	F	G	H	J	K	L	M	N	A	E	
3/8	2	1021015	-	-	0.33	0.66	0.91	0.38	0.44	1.44	0.38	1.78	2.17	2.49	1.03	0.38	-	-	0.06	0.13	
7/16	2 2/3	1021020	-	-	0.49	0.75	1.06	0.44	0.50	1.69	0.41	2.03	2.51	2.91	1.16	0.44	-	-	0.06	0.13	
1/2	3 1/3	1021029	-	-	0.79	0.81	1.19	0.50	0.64	1.88	0.46	2.31	2.80	3.28	1.31	0.50	-	-	0.06	0.13	
5/8	5	1021038	-	-	1.68	1.06	1.50	0.69	0.77	2.38	0.58	2.94	3.56	4.19	1.69	0.63	-	-	0.06	0.13	
3/4	7	1021047	-	-	2.72	1.25	1.81	0.81	0.89	2.81	0.69	3.50	4.15	4.97	2.00	0.75	-	-	0.06	0.25	
7/8	9 1/2	1021056	-	-	3.95	1.44	2.09	0.97	1.02	3.31	0.81	4.03	4.82	5.83	2.28	0.88	-	-	0.06	0.25	
1	12 1/2	1021065	-	-	5.66	1.69	2.38	1.06	1.15	3.75	0.92	4.69	5.39	6.56	2.69	1.00	-	-	0.06	0.25	
1 1/8	15	1021074	-	-	8.27	1.81	2.69	1.25	1.25	4.25	1.04	5.16	5.90	7.47	2.91	1.13	-	-	0.06	0.25	
1 1/4	18	1021083	-	-	11.7	2.03	3.00	1.38	1.40	4.69	1.16	5.75	6.69	8.25	3.25	1.29	-	-	0.06	0.25	
1 3/8	21	1021092	-	-	15.8	2.25	3.31	1.50	1.53	5.25	1.28	6.38	7.21	9.16	3.63	1.42	-	-	0.13	0.25	
1-1/2	30	1021110	1021129	1262407	18.8	2.38	3.62	1.62	1.63	5.75	1.39	6.88	7.73	10.00	3.88	1.53	-	-	0.13	0.25	
1-3/4	40	1021138	1021147	1262416	33.8	2.88	4.19	2.25	2.00	7.00	1.75	8.81	9.33	12.34	5.00	1.84	-	-	0.13	0.25	
2	55	1021156	1021165	1262425	49.9	3.25	4.81	2.40	2.25	7.75	2.00	10.16	10.41	13.68	5.75	2.08	-	-	0.13	0.25	
2-1/2	85	1021174	1021183	1262434	103	4.12	5.81	3.12	2.75	10.50	2.62	12.75	13.58	17.90	7.25	2.71	-	-	0.25	0.25	
3	120	1021192	-	1262443	162	5.00	6.50	3.63	3.25	13.00	3.00	14.62	15.13	21.50	7.88	3.12	-	-	0.25	0.25	
3-1/2	† 150	1021218	-	1262452	327	5.25	8.00	4.38	3.75	14.63	3.75	17.02	20.33	24.88	9.00	3.62	4.00	1.80	0.25	0.25	
4	† 175	1021236	-	1262461	318	5.50	9.00	4.56	4.25	14.50	4.00	18.00	21.20	25.68	10.00	4.00	4.00	1.80	0.25	0.25	
4-3/4	† 200	1021234	-	-	461	7.25	10.50	5.00	4.75	15.19	4.58	20.84	24.04	27.81	11.00	4.75	4.00	1.80	0.25	0.25	
5	† 250	1021243	-	-	608	8.50	12.00	5.62	5.00	18.50	4.85	23.62	24.87	32.61	13.00	5.00	4.00	1.80	0.25	0.25	
6	† 300	1021252	-	-	797	8.38	13.00	6.06	6.00	18.72	4.89	24.76	26.22	34.28	13.00	5.88	4.00	1.80	0.25	0.25	
7**	† 400	1021478	-	-	1289	8.25	14.00	7.25	7.00	22.50	6.50	26.00	29.66	40.25	13.00	6.00	4.00	1.80	0.25	0.25	

\* Note: Maximum Proof Load is 2 times the Working Load Limit. Minimum Ultimate Load is 5 times the Working Load Limit on 2 thru 21 metric tons. For sizes 30 thru 175 metric tons, Minimum Ultimate Load is 5.4 times the Working Load Limit for 200 thru 400 metric tons, Minimum Ultimate Load is 4 times the Working Load Limit. \*\* Cast Alloy Steel. † Furnished with Round Head Bolts with an handle for handling. For Working Load Limit reduction due to side loading applications, see page 94.

# Crosby® Alloy Easy-Loc® Shackles



## G-2140E

G-2140E meets the performance requirements of Federal Specification RR-C-271G, Type IVA, Grade B, Class 3, except for those provisions required of the contractor. For additional information, see page 452.

- Quenched and Tempered.
- Alloy bows, Alloy bolts.
- Forged Alloy Steel 200 thru 300 metric tons. Meets performance requirements of Grade 8 shackles.
- Working Load Limit is permanently shown on every shackle.
- 200, 250, and 300 metric ton shackle bows are Dimetcoated®; pins are Dimetcoated and painted red.
- All sizes are larger than 1-1/2 IN, **RFID EQUIPPED**.
- Approved for use at -40° C (-40° F) to 204° C (400° F).
- Shackles are Quenched and Tempered and can meet DNV impact requirements of 42 Joules (31 ft•lbf) at -20° C (-4° F).
- All sizes are individually proof tested to 2.0 times the Working Load Limit.
- Refer to page 87 for Crosby COLD TUFF® shackles that meet the additional requirements of DNV rules for certification of lifting applications - Loose Gear.
- Shackles are provided as follows:
  - Serialized bolt and bow
  - Material certification (chemical)
  - Magnetic particle inspected.
  - Certification must be requested at time of order.
- Meets or exceeds all requirements of ASME B30.26 including identification, ductility, design factor, proof load and temperature requirements. Importantly, these shackles meet other critical performance requirements including impact properties and material traceability, not addressed by ASME B30.26.
- Type Approval certification in accordance with ABS 2016 Steel Vessel Rules and 2016 ABS Guide for Certification of Lifting Appliances. Certificates available when requested at time of order and may include additional charges.
- Look for the Red Pin® . . . the mark of genuine Crosby quality.

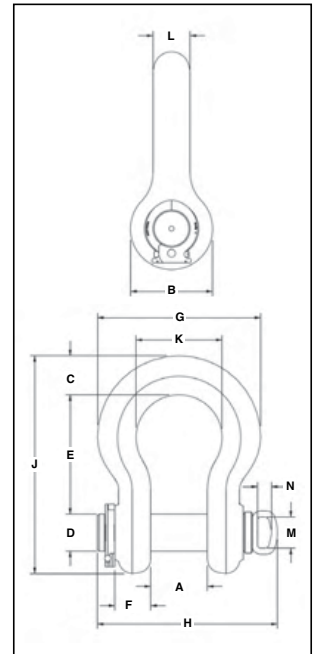

**SEE APPLICATION INFORMATION**  
 On Page 92 of the General Catalog  
 Para Español: [www.thecrosbygroup.com](http://www.thecrosbygroup.com)

## G-2140E Crosby® Alloy Easy-Loc Shackles

Nominal Shackle Size (in)	Working Load Limit (t)*	Stock No.	Weight Each (lb)	Dimensions (in)														Tolerance +/-	
				A	B	C	D +/- .02	E	F	G	H	J	K	L	M	N	A	E	
4-3/4	† 200	1021475	458	7.25	10.50	5.00	4.75	15.19	4.58	20.84	23.01	27.81	11.00	4.75	4.00	1.80	0.25	0.25	
5	† 250	1021484	597	8.50	12.00	5.63	5.00	18.50	4.48	23.63	23.84	32.63	13.00	5.00	4.00	1.80	0.25	0.25	
6	† 300	1021493	791	8.38	13.00	6.06	6.00	18.72	4.89	24.76	25.01	34.28	13.00	5.88	4.00	1.80	0.25	0.25	

\* Note: Maximum Proof Load is 2 times the Working Load Limit. For 200 thru 400 metric tons, Minimum Ultimate Load is 4 times the Working Load Limit. † Furnished with Round Head Bolts with a handle for handling. For Working Load Limit reduction due to side loading applications, see page 94.





**G-2160 / S-2160**

- All sizes Quenched and Tempered for maximum strength.
- Forged alloy steel from 7 thru 300 metric tons.
- Cast alloy steel from 400 thru 1550 metric tons.
- Proof tested as follows:
  - 7 thru 75 metric tons and 200 thru 300 metric tons: 2 x WLL.
  - 125 metric tons: 1.6 x WLL.
  - 400 metric tons and higher: 1.33 x WLL.
- All ratings are in metric tons, embossed on side of bow.
- G-2160, (7 thru 55t), are Hot Dip Galvanized and pins are painted red.
- G-2160, (75t and larger), bows are furnished Dimetcoated, and pins are Dimetcoated, then painted red.
- S-2160 bows and pins are painted red.
- Shackles, 30t and larger, are **RFID EQUIPPED**.
- Can be used to connect Synthetic Web Slings, Synthetic Round Slings or Wire Rope Slings.
- Increase in shackle bow radius provides minimum 58% gain in sling bearing surface and eliminates need for a thimble.
- Increases usable sling strength minimum of 15% and greatly improves life of wire rope slings.
- Approved for use at -40° C (-40° F) to 204° C (400° F).
- Bow and bolt are certified to meet charpy impact testing of 42 Joules (31 f • lbf) min. avg. at -20° C (-4° F).
- All 2160 shackles are individually proof tested and magnetic particle inspected. Crosby certification available at time of order.
- Shackles requiring ABS, Lloyds and other certifications are available upon special request and must be specified a time of order.
- Type approved and certification to DNV Rules for Certification of Lifting Appliances, and are produced in accordance with DNV MSA requirements. Databook is provided that includes required documents.
  - Serialization / Identification
  - Material Testing (Physical / Chemical / Charpy)
  - Proof Testing
- Look for the Red Pin® . . . the mark of genuine Crosby quality.

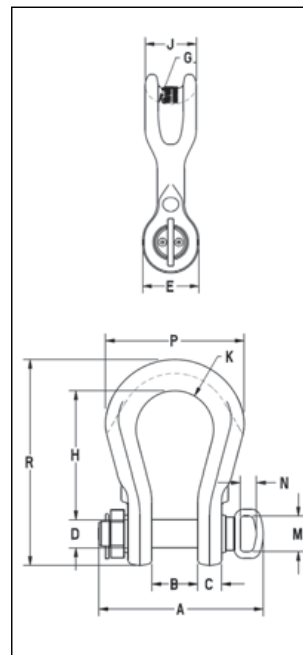

**SEE APPLICATION INFORMATION**

On Page 92 of the General Catalog  
Para Español: [www.thecrosbygroup.com](http://www.thecrosbygroup.com)

## G-2160 / S-2160 Crosby® “Wide Body” Shackles

Working Load Limit (t)*	Stock No.		Weight Each (lb)	Dimensions (in)														Effective Body Diameter
	G-2160	S-2160		A	B +/- .25	C	D +/- .02	E	G	H	J	K	M	N	P	R		
7	1021256	1021548	4.0	4.14	1.25	.69	.88	1.82	1.25	3.56	1.60	1.25	-	-	4.10	5.87	2.1	
12.5	1021265	1021557	8.8	5.38	1.69	.92	1.13	2.38	1.37	4.63	2.13	1.63	-	-	5.51	7.63	2.4	
18	1021274	1021566	14.9	6.69	2.03	1.16	1.38	2.69	1.50	5.81	2.50	2.00	-	-	6.76	9.38	2.8	
30	1021283	1021575	26.5	7.69	2.37	1.38	1.63	3.50	2.50	6.94	3.13	2.50	-	-	8.50	11.38	4.1	
40	1021285	1021584	46.0	9.28	2.88	1.69	2.00	4.00	1.75	8.06	3.75	3.00	-	-	10.62	13.62	3.6	
55	1021287	1021593	68.0	10.36	3.25	2.00	2.25	4.63	2.00	9.36	4.50	3.50	-	-	12.26	15.63	4.3	
75	1022101	-	112	15.04	4.13	2.12	2.75	5.34	3.75	11.53	5.00	3.64	4.00	1.80	12.28	18.66	6.3	
125	1022110	-	193	17.70	5.12	2.66	3.15	6.50	3.75	14.37	5.91	4.33	4.00	1.80	15.47	23.00	6.8	
200	1022118	-	420	19.35	5.91	2.94	4.12	8.41	5.25	18.91	8.56	5.42	4.00	1.80	20.47	30.44	9.5	
300	1022127	-	805	22.61	7.38	3.84	5.25	10.50	6.13	23.63	10.38	6.31	4.00	1.80	24.00	37.66	11.4	
400	1021334	-	1143	30.27	8.66	5.16	6.30	12.56	7.99	22.64	12.60	7.28	4.00	1.80	27.17	38.78	14.3	
500	1021343	-	1439	33.35	9.84	5.73	7.09	13.39	8.09	24.81	13.39	8.86	4.00	1.80	31.10	42.72	14.8	
600	1021352	-	2132	36.02	10.83	6.23	7.87	15.50	13.00	27.56	14.57	9.74	5.75	2.25	34.05	47.24	20.3	
700	1021361	-	2579	38.91	11.81	6.59	8.46	17.03	8.87	28.94	15.75	10.63	5.75	2.25	37.01	50.18	16.6	
800	1021254	-	3025	41.66	12.80	7.30	9.06	17.69	9.76	29.53	16.54	10.92	5.75	2.25	38.39	52.09	18.0	
900	1021389	-	3678	43.73	13.78	7.78	9.84	18.81	13.00	29.82	18.81	11.52	5.75	2.25	40.35	54.59	22.4	
1000	1021370	-	4079	45.98	14.96	8.33	10.63	20.00	10.26	29.92	18.11	12.11	5.75	2.25	42.32	55.31	19.3	
1250	1021272	-	5320	49.86	16.99	9.16	11.81	22.56	13.92	36.61	20.87	12.70	-	-	46.26	65.35	24.4	
1550	1021281	-	8302	54.89	18.31	11.10	12.60	24.25	12.52	42.32	22.82	13.29	-	-	51.81	74.63	23.9	

\*Note: Maximum Proof Load is 2 times the Working Load Limit on 75 thru 300 metric tons (except for 125 metric tons which is proof tested to 1.6 times the Working Load Limit). Minimum Ultimate Load is 5 times the Working Load Limit on 75 thru 300 metric tons. Maximum Proof Load is 1.33 times the Working Load Limit on 400 thru 1550 metric tons. Minimum Ultimate Load is 4.5 times the Working Load Limit on 400 thru 1550 metric tons.

# Crosby® Wide Body Shackles



**G-2160E**

- All sizes Quenched and Tempered for maximum strength.
- Forged alloy steel from 75 through 300 metric tons.
- Proof tested as follows:
  - 7-75 metric tons and 200-300 metric tons: 2 x WLL.
  - 125 metric tons: 1.6 x WLL.
- All ratings are in metric tons, embossed on side of bow.
- G-2160E, (75t and larger), bows are furnished Dimetcoated, and pins are Dimetcoated, then painted red.
- Shackles are **RFID EQUIPPED**.
- Can be used to connect HIGH STRENGTH Synthetic Web Slings, HIGH STRENGTH Synthetic Round Slings or Wire Rope Slings.
- Increase in shackle bow radius provides minimum 58% gain in sling bearing surface and eliminates need for a thimble.
- Increases usable sling strength minimum of 15% and greatly improves life of wire rope slings.
- Approved for use at -40° C (-40° F) to 204 degrees C (400° F).
- Bow and bolt are certified to meet charpy impact testing of 42 Joules (31 ft•lbf) min. avg. at -20° C (-4 degrees F).
- All 2160E shackles are individually proof tested and magnetic particle inspected. Crosby certification available at time of order.
- Shackles requiring ABS, Lloyds and other certifications are available upon special request and must be specified at time of order.
- Shackles have DNV Type Approval to Rules for Certification of Lifting Appliances, and are produced in accordance with DNV MSA requirements. Databook is provided that includes required documents.
  - Serialization / Identification
  - Material Testing (Physical / Chemical / Charpy)
  - Proof Testing
- Look for the Red Pin® . . . the mark of genuine Crosby quality.

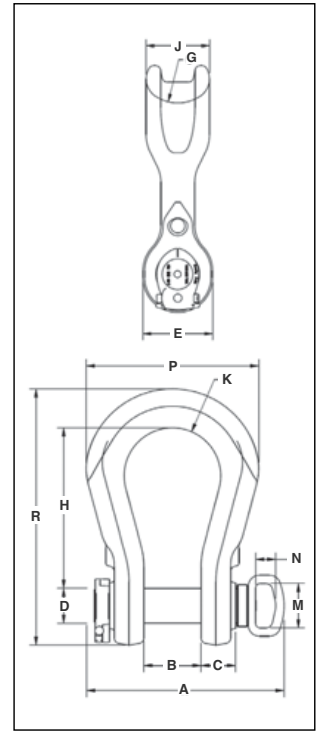

Shackles



**SEE APPLICATION INFORMATION**  
 On Page 92 of the General Catalog  
 Para Español: [www.thecrosbygroup.com](http://www.thecrosbygroup.com)

## G-2160E Crosby® Easy-Loc “Wide Body” Shackles

Working Load Limit (t)*	Stock No.		Weight Each (lb)	Dimensions (in)														Effective Body Diameter
	G-2160E	S-2160E		A	B +/- .25	C	D +/- .02	E	G	H	J	K	M	N	P	R		
75	1021500	–	110	15.04	4.13	2.39	2.75	5.34	3.75	11.54	5.00	3.64	4.00	1.80	12.64	18.66	6.3	
125	1021509	–	190	17.70	5.12	3.10	3.15	6.50	3.75	14.37	5.91	4.33	4.00	1.80	15.47	23.00	6.8	
200	1021518	–	408	19.35	5.91	3.39	4.12	8.41	5.25	18.91	8.56	5.42	4.00	1.80	20.27	30.44	9.5	
300	1021527	–	787	22.61	7.38	4.30	5.25	10.50	6.13	23.63	10.38	6.31	4.00	1.80	23.93	37.51	11.4	

\*Note: Maximum Proof Load is 2 times the Working Load Limit on 75 thru 300 metric tons (except for 125 metric tons which is proof tested to 1.6 times the Working Load Limit). Minimum Ultimate Load is 5 times the Working Load Limit on 75 thru 300 metric tons.



**G-2170**  
Grommet  
Shackle



Scan our QR Code with your smart device to visit the online flye .

- All sizes Quenched and Tempered for maximum strength.
- All sizes cast alloy steel.
- All ratings are in metric tons, embossed on side of bow.
- G-2170 bows are furnished Dimetcoated and pins are Dimetcoated, then painted red.
- All sizes are **RFID EQUIPPED** in bow and pin.
- Designed for use with single or double large diameter grommets.
- Extra large sling contact area improves efficiency of the grommet sling
- Shackles utilize new Easy-Loc bolt system
- Large machined flat on ears that can be drilled and tapped for adapting other accessories.
- Increases usable sling strength minimum of 60% and greatly improves life of grommet slings.
- Bow and bolt are certified to meet charpy impact testing of 42 Joules (31 ft•lbf) min. avg. at -20° C (-4° F).
- All 2170 shackles are individually proof tested and magnetic particle inspected.
- Shackles requiring ABS, Lloyds, and other certifications are available upon special request and must be specified at time of order .
- All 2170 shackles can meet requirements of DNV Rules for Certification of Lifting Appliances upon special request and must be specified t time of order.
  - Serialization / Identificatio
  - Material Testing (Physical / Chemical / Charpy)
  - Proof Testing
- Look for the Red Pin®...the mark of genuine Crosby quality.

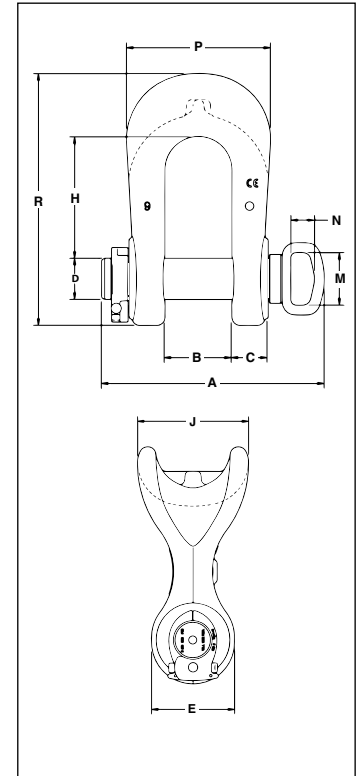

**SEE APPLICATION INFORMATION**

On Page 92 of the General Catalog  
Para Español: [www.thecrosbygroup.com](http://www.thecrosbygroup.com)

## G-2170 Crosby® Grommet Shackles

Working Load Limit (t)*	Stock No.	Weight Each (lb)	Dimensions (in)											Effective Body Diameter
			A	B +/- .25	C	D +/- .02	E	H	J	M	N	P	R	
75	1023147	115	15.04	4.13	2.39	2.75	5.50	7.77	7.50	4.00	1.80	9.38	16.20	11.25
125	1023156	179	17.01	5.13	2.75	3.15	6.72	9.31	9.00	4.00	1.80	11.00	19.25	13.50
200	1023174	374	19.35	5.91	3.39	4.12	9.00	11.64	12.90	4.00	1.80	13.63	25.01	18.45
300	1023183	692	22.61	7.38	4.30	5.25	11.13	15.20	15.50	4.00	1.80	17.00	31.82	22.75
500	1022119	1671	29.95	9.84	6.00	7.09	13.75	19.72	20.00	4.00	1.80	23.00	41.44	30.00

\* Note: Maximum Proof Load is 2 times the Working Load Limit on 75 thru 300 metric tons. Minimum Ultimate Load is 5 times the Working Load Limit on 75 thru 300 metric tons. Maximum Proof Load is 1.33 times the Working Load Limit on 500 metric tons. Minimum Ultimate Load is 4.5 times the Working Load Limit on 500 metric tons.



# Crosby® COLD TUFF® Shackles



G-2130CT / G-2140CT



- Forged - Quenched and Tempered, with alloy bolt.
  - G-2130CT - Carbon Steel
  - G-2140CT - Alloy Steel
- Working Load Limit permanently shown on every shackle.
- Individually serialized with certification
- Fatigue Rated (G-2130CT only).
- Shackles 25t and larger are **RFID EQUIPPED**.
- All sizes are individually proof tested to 2.0 times the Working Load Limit.
- Finish is inorganic zinc primer.
- Bow and bolt are certified to meet charpy impact testing of 42 Joules (31 f • lbf) min. avg. at -20° C (-4° F).
- Individually mag inspected with certification
- Type Approval and certification in accordance with DNV 2.7-1 O shore Containers, and Rules for Certification of Lifting Appliances, DNV-OS-E101 and are produced in accordance with DNV MSA requirements, including required documents.
- DNV certified minimum design temperature -4° . May be used at -50°F (-45° C) in non DNV applications.
- Refer to page 167 for COLD TUFF® Master Links and Master Link assemblies.

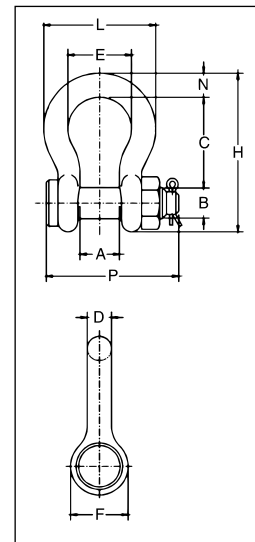

Shackles



**SEE APPLICATION INFORMATION**  
 On Page 92 of the General Catalog  
 Para Español: www.thecrosbygroup.com

## Crosby® G-2130CT COLD TUFF®

Nominal Shackle Size (in)	Working Load Limit (t)*	G-2130CT Stock No.	Weight Each (lb)	Dimensions (in)										Tolerance +/-	
				A	B	C	D	E	F	H	L	N	P	A	C
3/4	4-3/4	1260568	2.72	1.25	.88	2.81	.75	2.00	1.81	4.97	3.50	.81	4.25	.06	.25
7/8	6-1/2	1260577	3.87	1.44	1.00	3.31	.88	2.28	2.09	5.83	4.03	.97	4.71	.06	.25
1	8-1/2	1260586	5.66	1.69	1.13	3.75	1.03	2.69	2.38	6.56	4.69	1.06	5.38	.06	.25
1-1/8	9-1/2	1260595	8.26	1.81	1.25	4.25	1.13	2.91	2.69	7.47	5.16	1.25	5.90	.06	.25
1-1/4	12	1260604	11.71	2.03	1.38	4.69	1.29	3.25	3.00	8.25	5.75	1.38	6.63	.06	.25
1-3/8	13-1/2	1260613	15.1	2.25	1.50	5.25	1.38	3.63	3.31	9.16	6.38	1.50	7.21	.13	.25
1-1/2	17	1260622	20.8	2.38	1.63	5.75	1.54	3.88	3.63	10.00	6.88	1.62	7.66	.13	.25
1-3/4	25	1260633	33.9	2.88	2.00	7.00	1.84	5.00	4.19	12.34	8.86	2.25	9.19	.13	.25

Bolt Type Anchor shackle with thin head bolt - nut with cotter pin. Meets the performance requirements of Federal Specification RR-C-271 Type IVA, Grade A, Class 3, except for those provisions required of the contractor. For additional information, see page 466.



\* NOTE: Maximum Proof Load is 2 times the Working Load Limit. 4-3/4t - 25t, Minimum Ultimate Load is 5.4 times the Working Load Limit. For Working Load Limit reduction due to side loading applications, see page 94.

## Crosby® G-2140CT COLD TUFF® Shackles

Nominal Shackle Size (in)	Working Load Limit (t)*	G-2140CT Stock No.	Weight Each (lb)	Dimensions (in)										Tolerance +/-	
				A	B	C	D	E	F	H	L	N	P	A	C
1-1/2	30	1260801	20.8	2.38	1.63	5.75	1.54	3.88	3.62	10.00	6.88	1.62	7.73	.13	.25
1-3/4	40	1260812	33.9	2.88	2.00	7.00	1.84	5.00	4.19	12.34	8.81	2.25	9.33	.13	.25
2	55	1260823	52.0	3.25	2.25	7.75	2.08	5.75	4.81	13.68	10.16	2.40	10.41	.13	.25
2-1/2	85	1260834	96.0	4.12	2.75	10.50	2.72	7.25	5.69	17.84	12.87	3.12	13.58	.25	.25
3	120	1260843	178.0	5.00	3.25	13.00	3.11	7.88	6.50	21.50	14.36	3.63	15.13	.25	.25
3-1/2	† 150	1260852	265.0	5.25	3.75	14.63	3.62	9.00	8.00	24.62	16.50	4.12	17.62	.25	.25
4	† 175	1260861	338.0	5.50	4.25	14.5	4.10	10.00	9.00	25.69	18.42	4.56	20.37	.25	.25
4-3/4	† 200	1260870	450.0	7.25	4.75	15.63	4.50	11.00	10.50	29.25	21.00	6.00	21.21	.25	.25
5	† 250	1260889	600.0	8.50	5.00	20.00	4.50	13.00	12.00	35.00	24.50	6.50	22.68	.25	.25

Bolt Type Anchor shackle with thin head bolt - nut with cotter pin. Meets the performance requirements of Federal Specification RR-C-271 Type IVA, Grade B, Class 3, except for those provisions required of the contractor. For additional information, see page 466.



\* NOTE: Maximum Proof Load is 2 times the Working Load Limit. 30t - 175t, Minimum Ultimate Load is 5.4 times the Working Load Limit. 200t and larger, Minimum Ultimate Load is 4 times the Working Load Limit. † Furnished with Round Head Bolts with welded handle. For Working Load Limit reduction due to side loading applications, see page 94.



# Shackle Bolt Securement MADE EASY

The Patent Pending Easy-Loc V2™ shackle bolt securement system will change the way you make your next critical lift. It's shackle bolt securement made as easy as 1,2,3.

Wide opening ergonomic grip provides easy access for all hand sizes

Both shackle and pin are RFID equipped

316 stainless steel design resists corrosion

The new Easy-Loc V2™ can be retrofitted on all original Crosby Easy-Loc® Shackles

No cotter pin or tools required



**1** Open collar



**2** Push collar onto bolt



**3** Close collar

- No cotter pins or tools required, reducing install/release time up to 90%
- Meets all industry standards
- Up to 60% lighter than conventional nut and cotter pin design

**Crosby**®

Made in the U.S.A.

Contact your local authorized Crosby distributor or visit at [thecrosbygroup.com](http://thecrosbygroup.com)



# Crosby® Specialty Shackles



**S-209T  
THEATRICAL  
SHACKLE**

- Sizes: 3/8" through 3/4"
- Capacities: 1 through 4-3/4 metric tonnes.
- Forged - Quenched and Tempered, with alloy pins.
- Working Load Limit permanently shown on every shackle.
- Flat black baked on powder coat finish
- Fatigue Rated.
- Industry leading 6 to 1 design factor.
- Screw pin anchor shackles meet the performance requirement of Federal Specification RR-C-271G, Type IVA, Grade A, Class 2, except for those provisions required of the contractor.
- Meets the performance requirements of EN 13889.
- Meets or exceeds all requirements of ASME B30.26 including identification, ductility, design factor, proof load and temperature requirements. Importantly, these shackles meet other critical performance requirements including fatigue life, impact properties and material traceability, not addressed by ASME B30.26.

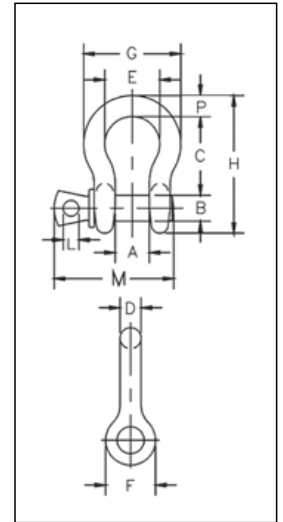

Shackles



**SEE APPLICATION INFORMATION**  
On Page 92 of the General Catalog  
Para Español: [www.thecrosbygroup.com](http://www.thecrosbygroup.com)

## S-209T Theatrical Shackles

Nominal Size (in)	Working Load Limit (t)*	S-209T Stock No.	Weight Each (lb)	Dimensions (in)											Tolerance +/-	
				A	B	C	D	E	F	G	H	L	M	P	C	A
3/8	1	1018706	.31	.66	.44	1.44	.38	1.03	.91	1.78	2.49	.25	2.02	.38	.13	.06
7/16	1-1/2	1018724	.38	.75	.50	1.69	.40	1.16	1.06	2.03	2.91	.31	2.37	.44	.13	.06
1/2	2	1018742	.72	.81	.63	.188	.50	1.31	1.19	2.31	3.28	.38	2.69	.50	.13	.06
5/8	3-1/4	1018760	1.37	1.06	.75	2.38	.63	1.69	1.50	2.94	4.19	.44	3.34	.69	.13	.06
3/4	4-3/4	1018778	2.35	1.25	.88	2.81	.75	2.00	1.81	3.50	4.97	.50	3.97	.81	.25	.06

\* Minimum Ultimate Load is 6 times the Working Load Limit. Maximum Proof Load is 2.0 times the Working Load Limit.

### **S-209T...The "Crosby"**

When you're looking for the top-named shackle used for theatrical and stage rigging applications, ask for a "Crosby"—the name synonymous with quality, safety and heavy lifting. The S-209T shackle is enhanced with a flat black baked-on power coat finish that causes the shackle to blend in with stage surroundings. This guarantees "behind-the-scene" strength and dependability without detracting the eye from on-stage action.





# Crosby® Release & Retrieve ROV Shackle

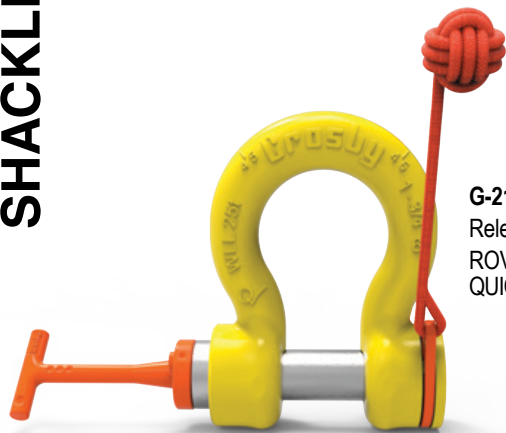

**G-2100**  
Release & Retrieve  
ROV Shackle with  
QUIC-Thread Bolt



**G-2110**  
Release & Retrieve  
ROV Shackle with  
Non - Thread Bolt

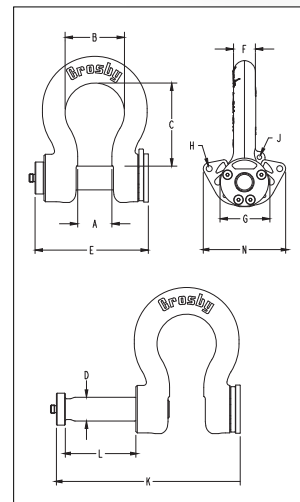
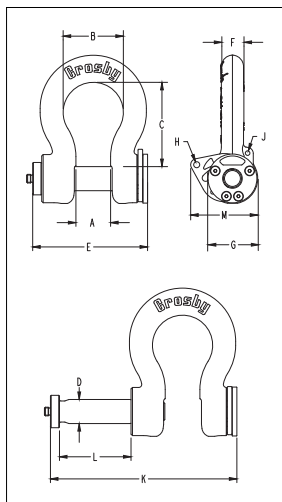

- Forged alloy bow with an industry best 6 to 1 performance design factor.
- Patent pending captured bolt can withstand over 2,000 lbs. (907 kg) of pull-out force.
- Galvanized bow with an API RP 17H color compliant coating.
- Galvanized alloy bolt (Non-Threaded) (**G-2110**)
- On average, QUIC-Thread bolt requires only 3.5 rotations for full engagement (**G-2100**)
- Raised pad for serialization.
- API RP 17H compliant 316 stainless steel handles available in T, D, F, and Eye models (sold separately)
- Built in eyelets for optional tether points.
- Monkey fist(s) included
- Capacities from 9-1/2t through 85t.
- Forged Steel, Quenched & Tempered, with alloy pins.
- Working Load Limit permanently shown on every shackle.
- **QUIC-CHECK®** deformation and angle indicators forged on the bow.

Load Rated®



**SEE APPLICATION INFORMATION**  
On Page 92 of the General Catalog  
Para Español: [www.thecrosbygroup.com](http://www.thecrosbygroup.com)

## G-2100 ROV Release & Retrieve Shackle — QUIC-Threaded

Working Load Limit (t)*	Stock No.	Weight Each (lb)	Dimensions (in)											
			A	B	C	D	E	F	G	H	J	K	L	N
9.5	2038739	11.4	1.81	2.91	4.25	1.25	7.33	1.16	2.68	0.38	0.31	11.54	4.21	4.97
12	2038762	13.8	2.03	3.25	4.69	1.38	7.75	1.29	3.00	0.38	0.31	12.25	4.50	4.97
17	2038785	23.7	2.38	3.88	5.75	1.63	8.54	1.53	3.62	0.50	0.31	13.74	5.20	6.28
25	2038614	38.6	2.88	5.00	7.00	2.00	9.54	1.84	4.20	0.50	0.38	15.48	5.94	6.94
35	2038808	51.2	3.25	5.75	7.74	2.28	10.41	2.08	4.82	0.50	0.38	16.97	6.56	6.94
55	2038831	108	4.12	7.25	10.49	2.78	12.61	2.72	5.81	0.50	0.38	20.74	8.13	8.53
85	2038877	157	5.00	7.88	12.98	3.28	14.23	3.12	6.50	0.50	0.50	23.61	9.38	8.53

\*Minimum Ultimate Load is 6 times the Working Load Limit in metric tons. \*Note: Maximum Proof Loads are 2xWLL in metric tons.

## G-2110 ROV Release & Retrieve Shackle — Non-Threaded

Working Load Limit (t)*	Stock No.	Weight Each (lb)	Dimensions (in)											
			A	B	C	D	E	F	G	H	J	K	L	N
9.5	2038740	11.4	1.81	2.91	4.25	1.25	7.33	1.16	2.68	0.38	0.31	11.54	4.21	4.97
12	2038763	13.8	2.03	3.25	4.69	1.38	7.75	1.29	3.00	0.38	0.31	12.25	4.50	4.97
17	2038786	23.7	2.38	3.88	5.75	1.63	8.54	1.53	3.62	0.50	0.31	13.74	5.20	6.28
25	2038621	38.6	2.88	5.00	7.00	2.00	9.54	1.84	4.20	0.50	0.38	15.48	5.94	6.94
35	2038809	51.2	3.25	5.75	7.74	2.28	10.41	2.08	4.82	0.50	0.38	16.97	6.56	6.94
55	2038832	108	4.12	7.25	10.49	2.78	12.61	2.72	5.81	0.50	0.38	20.74	8.13	8.53
85	2038878	157	5.00	7.88	12.98	3.28	14.23	3.12	6.50	0.50	0.50	23.61	9.38	8.53

\*Minimum Ultimate Load is 6 times the Working Load Limit in metric tons. \*Note: Maximum Proof Loads are 2xWLL in metric tons.

# ROV Handles Options and Configurations



“D” Handle

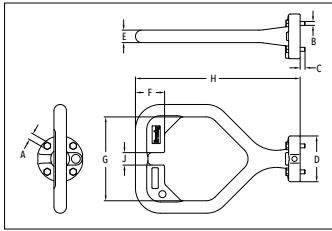

“F” Handle

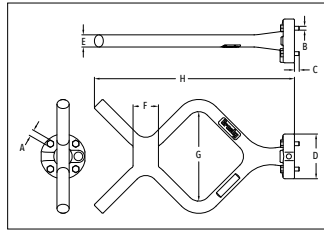

“Eye” Handle

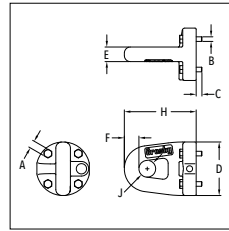

“T” Handle

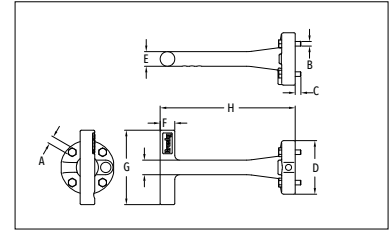

- New Interchangeable handles for ROV shackle bolts.
- For use with G-2100 and G-2110 ROV shackles only.
- Handles are stainless steel and Painted fluorescent orange.
- “D” and “F” handle kits available containing handle, retaining bolts, and individual packet of Loctite for easy installation.
- Handles are RFID equipped.



**NOTE: ROV Hooks available on page 130 and 131.**

## G-42100H ROV Handles

Handle Style	Stock No.	Weight Each (lb)	Dimensions (in)									
			A	B	C	D	E	F	G	H	J	K
D	1021324	4.5	0.28	0.24	0.29	2.75	0.75	1.75	5.04	9.9	0.75	-
F	1021315	5.0	0.28	0.24	0.29	2.75	0.75	1.56	5.5	12.29	-	-
T	1021306	2.4	0.28	0.24	0.29	2.75	0.75	0.75	3.82	6.18	-	0.75
Eye	1021333	2.1	0.28	0.24	0.29	2.75	0.75	0.75	-	3.69	0.86	-



G-209R ROV SHACKLE

- Capacities from 6-1/2t through 55t.
- Forged Steel, Quenched & Tempered, with alloy pins.
- Working Load Limit permanently shown on every shackle.
- Fatigue rated.
- **QUIC-CHECK®** deformation and angle indicators forged on the bow.
- All ROV shackle bows are galvanized, then painted fluorescent yellow.
- Look for the Red Pin® . . . the mark of genuine Crosby quality.

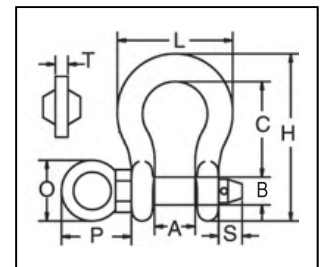

**SEE APPLICATION INFORMATION**

On Page 92 of the General Catalog  
Para Español: [www.thecrosbygroup.com](http://www.thecrosbygroup.com)

## G-209R Subsea Shackles

Working Load Limit (t)*	G-209R Stock No.	Weight Each (lb)	Dimensions (in)									
			A +/- .25	B	C	H	L	O	P	S	T	
6-1/2	1020872	3.62	1.44	1.00	3.31	5.83	4.03	1.18	2.28	.65	.39	
8-1/2	1020902	5.03	1.69	1.13	3.75	6.56	4.69	1.18	2.40	.73	.39	
9-1/2	1020932	7.41	1.81	1.25	4.25	7.47	5.16	2.28	3.27	.75	.47	
12	1020952	9.50	2.03	1.38	4.69	8.25	5.75	2.28	3.31	.89	.47	
13-1/2	1020972	13.53	2.25	1.50	5.25	9.16	6.38	2.36	3.58	.91	.59	
17	1020992	17.20	2.38	1.63	5.75	10.00	6.88	2.36	3.66	1.18	.59	
25	1021102	27.78	2.88	2.00	7.00	12.34	8.86	2.16	4.49	1.14	.69	
35	1021125	45.00	3.25	2.25	7.75	13.68	9.97	2.60	5.12	1.18	.79	
55	1021158	85.75	4.13	2.75	10.50	17.84	12.87	2.76	5.63	1.50	.98	

\* Minimum Ultimate Load is 5 times the Working Load Limit. Maximum Proof Load is 2.0 times the Working Load Limit.

## Round Pin Shackles



G/S-213



G/S-215

**Round Pin Shackles** can be used in tie down, towing, suspension or lifting applications where the load is strictly applied in-line. Round pin shackles should never be used in rigging applications to gather multiple sling legs, or where side loading conditions may occur.

## Bolt-Type Shackles



G/S-2130

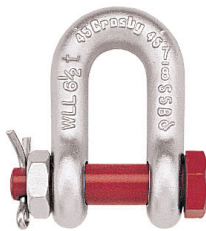

G/S-2150



G/S-2140



G/S-2160

**Bolt-Type Shackles** can be used in any application where round pin or screw pin shackles are used. In addition, they are recommended for permanent or long term installations and where the load may slide on the shackle pin causing the pin to rotate. The bolt-type shackle's secondary securement system, utilizing a nut and cotter, eliminates the requirement to tighten pin before each lift or movement of load.

## Screw Pin Shackles



G/S-209



S-209T



G-209A



G/S-210



S-253



G-2169

**Screw Pin Shackles** are used in Pick and Place\* applications. For permanent or long-term installations, Crosby recommends the use of bolt type shackles.

If you choose to disregard Crosby's recommendation, the screw pin shall be secured from rotation or loosening (Page 93).

Screw pin shackles can be used for applications involving side-loading circumstances. Reduced working load limits are required for side-loading applications. While in service, do not allow the screw pin to be rotated by a live line, such as a choker application.

\* Pick and Place application: Pick (move) a load and place as required. Tighten screw pin before each pick.

## QUIC-CHECK®



All Crosby Shackles, with the exception of 2160, 2169, 2170, 252 and 253 styles incorporate markings forged into the product that address an easy to use **QUIC-CHECK®** feature. Angle indicators are forged into the shackle bow at 45 degree\*\* angles from vertical. These are utilized on screw pin and bolt type shackles to quickly check the approximate angle of a two-legged hitch, or quickly

check the angle of a single leg hitch when the shackle pin is secured and the pull of the load is off vertical (side loaded), thus requiring a reduction in the working load limit of the shackle.

\*\* **Round Pin Shackles** utilize the 45 degree **QUIC-CHECK®** indicators to ensure load is applied strictly in-line.

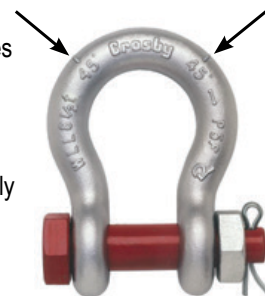

G-2130



## RIGGING PRACTICE SHACKLES

Screw pin shall be fully engaged. If designed for a cotter pin, it shall be used and maintained. Applied load should be centered in the bow to prevent side loading. Multiple sling legs should not be applied to the pin. If side loaded, the rated load shall be reduced according to Table 1 on pages 94.

## Screw Pin Shackles Pin Security

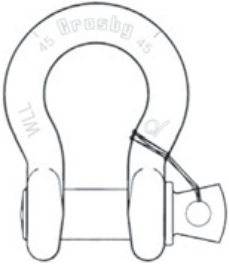

### MOUSE SCREW PIN WHEN USED IN LONG-TERM OR HIGH-VIBRATION APPLICATIONS.

Mouse or Mousing (screw pin shackle) is a secondary securement method used to secure screw pin from rotation or loosening. Annealed iron wire is looped through hole in collar of pin and around adjacent leg of shackle body with wire ends securely twisted together.

## Shackles

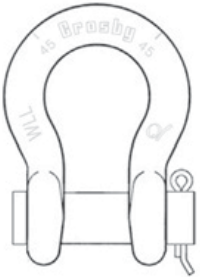

### ROUND PIN

Do not side load, do not use as a collector ring, always use cotter pin.

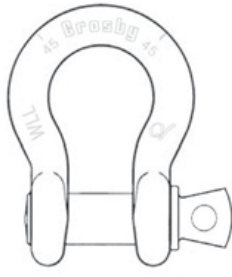

### SCREW PIN

Use when picking and placing a load, tighten pin prior to each lift.

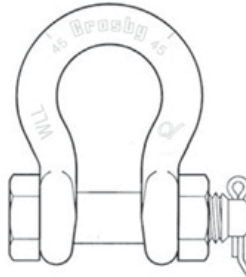

### BOLT-TYPE

Use in permanent or long-term installations, always use nut and cotter.

## Connection of Slings to Shackles



Diameter of shackle must be greater than wire rope diameter if no thimble in eye.



Shackle must be large enough to avoid pinching of synthetic slings.

## Bolt-Type Shackles

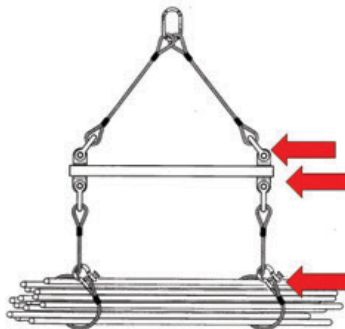

Use Bolt-Type Shackle when a permanent or long-term connection.

Use a screw pin shackle when it will be a temporary connection.

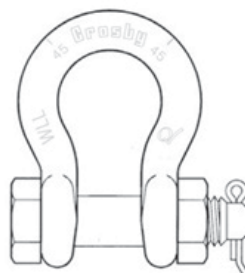

## WIRE ROPE SLINGS AND CONNECTIONS TO FITTINGS

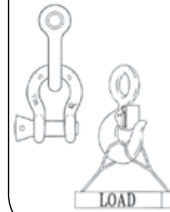

USE A THIMBLE TO PROTECT SLING AND TO INCREASE D/d

NEVER PLACE EYE OVER A FITTING SMALLER DIAMETER OR WIDTH THAN THE ROPE'S DIAMETER

## WIRE ROPE SLINGS AND CONNECTIONS TO FITTINGS

NEVER PLACE A SLING EYE OVER A FITTING WITH A DIAMETER OR WIDTH GREATER THAN ONE HALF THE NATURAL LENGTH OF THE EYE

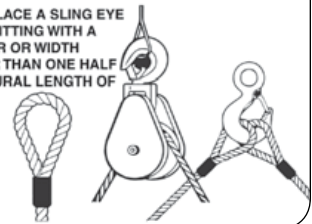

## SYNTHETIC SLINGS RATED LOAD

FOLDING, BUNCHING OR PINCHING OF SYNTHETIC SLINGS, WHICH OCCURS WHEN USED WITH SHACKLES, HOOKS OR OTHER APPLICATIONS, WILL REDUCE THE RATED LOAD



BUNCHING



PINCHING

ASME B30.9

## CHOKER HITCH FORMED

WITH SHACKLES

WITH CHOKER HOOK



PLACE PIN IN EYE OF SLING

CORRECT!



## CROSBY SHACKLES POINT LOADING

POINT LOADING OF CROSBY SHACKLE BOWS IS ACCEPTABLE

POINT LOADING OF CROSBY SHACKLE PINS IS ACCEPTABLE AS LONG AS LOAD IS REASONABLY CENTERED ON THE PIN

ALTHOUGH POINT LOADING IS ACCEPTABLE, A PAD EYE WIDTH OF 50%-80% OR MORE OF SHACKLE SPREAD IS BEST PRACTICE

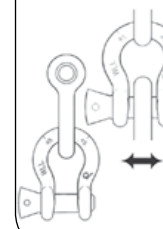

### Point Loading of Crosby® Shackles

It has been determined that all Crosby® shackles can be point-to-point loaded to the Working Load Limit without bending of the pin/bolt. This loading can be bow-to-bow, bow-to-pin, or pin-to-pin (if there is not interference between the diameter of the shackle ears). However, caution should be given to maintain the load at the center of the span by spacers so the load will not slide over to one side, and overload that ear. See "Off Center Loading Of Crosby® Screw Pin & Bolt Type Shackles – 3/16" to 3" Sizes"

### Angular Loading Of Crosby® Screw Pin & Bolt Type Shackles

Crosby® has made representative tests with smaller size shackles with the load applied at 90 degrees to the normal plane of loading (ie. in-line). The test results indicated that in order to maintain a proof load of 2 times the Working Load Limit (2 x WLL), the Working Load Limit should be reduced to 50% (ie. one-half the catalog working load rating). **DO NOT SIDE LOAD G/S-213 OR G/S-215 ROUND PIN SHACKLES.** Calculations based on the above test indicates the Working Load Limit should be reduced as shown below for loads applied at various angles to the normal plane of loading:

Angle loads must be applied in the plane of the bow.

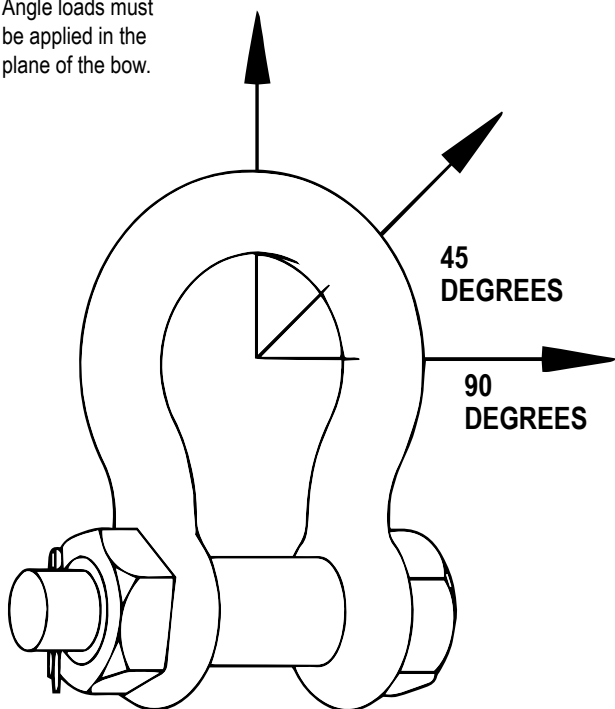

### SIDE LOADED RATING REDUCTION TABLE FOR 3/16" - 3" (120 METRIC TONS)

Table 1	
Side Loading Reduction Chart for Screw Pin and Bolt Type Shackles Only+	
Angle of Side Load from Vertical In-Line of Shackle	Adjusted Working Load Limit
0° - 10° In-Line*	0% of Rated Working Load Limit
11° - 20° from In-Line*	15% of Rated Working Load Limit
21° - 30° from In-Line*	25% of Rated Working Load Limit
31° - 45° from In-Line*	30% of Rated Working Load Limit
46° - 55° from In-Line*	40% of Rated Working Load Limit
56° - 70° from In-Line*	45% of Rated Working Load Limit
71° - 90° from In-Line*	50% of Rated Working Load Limit

+ In-Line load is applied perpendicular to pin. \* **DO NOT SIDE LOAD ROUND PIN SHACKLE.**

Table 1	
SHACKLE SIZE GREATER THAN 3" ANGLE FROM IN-LINE (DEGREES) REDUCTION IN WLL	
0° - 5° In-Line*	0% of Rated Working Load Limit
6° - 10° from In-Line*	15% of Rated Working Load Limit
>10° from In-Line*	ANALYSIS REQ'D.

For shackles larger than 125 metric tons, where the angle of the side load is greater than 5 degrees, contact Crosby Engineering.

### INCLUDED ANGLE - SHACKLES

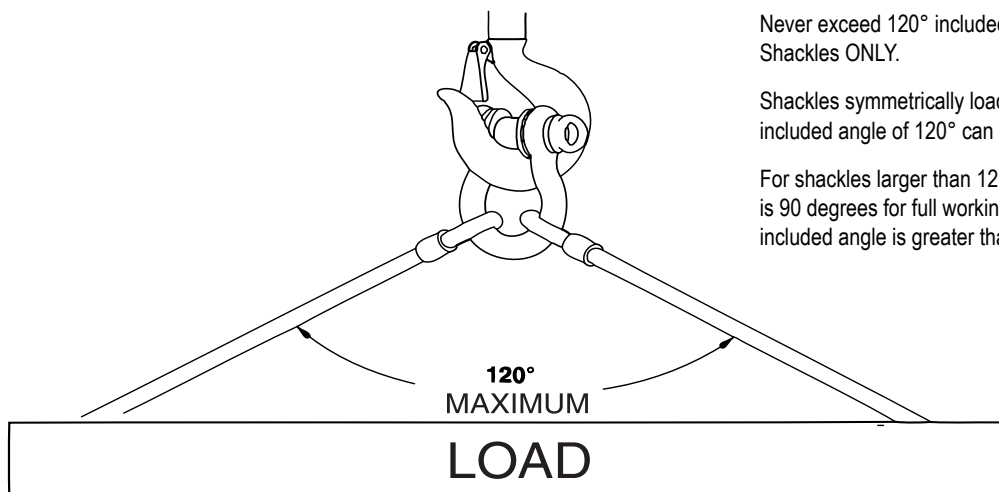

Never exceed 120° included angle. Use Bolt Type and Screw Pin Shackles ONLY.

Shackles symmetrically loaded with two leg slings having a maximum included angle of 120° can be utilized to full Working Load Limit.

For shackles larger than 125 metric tons, the maximum included angle is 90 degrees for full working load limit. Contact Crosby Engineering if included angle is greater than 90 degrees.





# SLING SAVER FITTINGS

With Product Warnings and Application Information



# Lifting the World into the Future!



Cover protects sling as well as keeps it positioned correctly.

Pin threads into shackle and is secured with locknut. No retaining pin to snag the sling material.

Crosby, a world leader in lifting accessories, has developed the first full line of fittings designed for use with synthetic slings. For a "Systems" approach to rigging hardware for synthetics, Crosby's Sling Saver line is the choice.

Spool reduces sling wear.

Design allows for easy connection to other fittings.

Crosby's new Sling Saver line is designed to eliminate "bunching". The result: The full efficiency of the synthetic sling (Round or Webbing) can be achieved. Conventional hardware can reduce the efficiency of the sling significantly. Available in sizes 1.5" to 3" (35mm - 75mm). Capacity: 3-1/4 Tons to 8-1/2 Tons (2.95t-7.70t) Working Load Limit.











## Sling Saver®

## Crosby®



## WITH CROSBY'S NEW SLING SAVER® LINE OF HARDWARE, YOU WILL GET THE FULL RATED STRENGTH OF THE SLING AND EXTEND ITS LIFE.

### RECOMMENDED APPLICATION CHART

APPLICATION	USE	COMMENTS
Web Slings, connect to Pad Eye, Eye Bolt, or Lifting Lug.	S-281 Sling Saver Web Sling Shackle – page 99 	Always Ensure Rated Working Load Limits are Greater than the Load Placed on the Fitting. Designed for use with Type III (Eye & Eye), Class 7, 2 ply webbing & Synthetic Round Slings. Also accommodates single ply and endless slings.
Web Slings or Roundslings, connecting to Pad Eye, Eye Bolt, or Lifting Lug.	S-253 or S-252 Sling Saver Shackle – page 100 	
Connect two S-252 or S-253 Sling Saver shackles together.	S-256 Link Plate – page 101 	
To keep the load centered on the Pin, thus keeping the sling positioned correctly in the shackle bow.	S-255 Spool – page 101 	
Web Slings or Roundslings connecting to Master Links, Rings, or Crosby 320N Eye Hooks.	S-280 Sling Saver Web Connector with spool – page 98 	
High Strength, High Capacity Web or Roundslings.	WSL-320A Synthetic Sling Hook – page 102 	
Choking with Web Slings or Roundslings.	S-287 Sliding Choker Hook – page 103 	
Master Links or Master Link Assembly to be sewn into eye of Web Sling or attached utilizing web connector.	Welded Master Link A-344 and Master Link Assembly A-347 – pages 245 - 246 	
Master Links or Master Link Assembly to be sewn into eye of Web Sling or attached utilizing web connector.	Welded Master Link A-342 and Master Link Assembly A-345 – pages 160 - 161 	
Connecting High Performance slings to master links or eye hooks and to other High Performance slings.	S-237 or S-238 High Performance Connectors – page 104 	
Wide Body Shackles greatly improve wearability of wire rope slings.	S/G-2160 "Wide Body" bolt type Shackles – pages 84 - 85 S/G-2169 "Wide Body" Screw Pin Shackles – page 78 	

Crosby Sling Saver hardware meets the requirements for minimum stock diameter or thickness and effective contact width shown in the recommended standard specification for synthetic Polyester Round Slings by the Web Sling and Tie Down Association. WSTDA-RS1 (revised 2010).

# Sling Saver® Web Connector



- All Alloy construction.
- Durable vinyl cover that:
  - Protects sling at eye
  - Keeps sling positioned correctly on spool.
- Design Factor of 5:1.
- Connects Synthetic Web and Synthetic Round Slings to conventional Crosby hardware.
- Makes a field assembled bridle quick and easy.
- No retaining pin to snag sling material.
- Increased radius of spool gives wider sling bearing surface resulting in an increased area for load distribution, thus:
  - Increasing Synthetic Sling efficiency as compared to standard anchor and chain shackle bows and conventional eye hooks. This allows 100% of the slings rated Working Load Limit to be achieved.
  - Allowing better load distribution on internal fibers.
- Replacement kit for spool and web cover available.
- Designed for use with Type III (Eye & Eye), Class 7, 2 ply webbing & Synthetic Round Slings. Also accommodates single ply and endless slings.

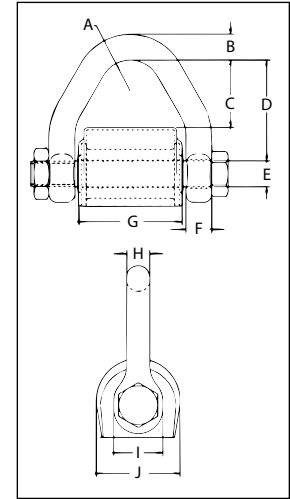

Crosby Sling Saver hardware meets the requirements for minimum stock diameter or thickness, and effective contact width shown in the Recommended Standards Specification for Synthetic Polyester Round Slings by the Web Sling & Tie Down Association. WSTDA-RS1.

## S-280 Web Connector

Round Sling Size (No.)	Web Slings*			Working Load Limit (Tons)†	S-280 Stock No.	Weight Each (lb)	Dimensions (in)									
	Webbing Width (in)	Eye Width (in)	Ply				A	B	C	D	E	F	G	H	I	J
1 & 2	2	2	2	3-1/4	1021681	1.5	.75	.62	1.63	2.44	.63	.62	2.13	.56	1.19	2.02
3	3	1.5	2	4-1/2	1021690	1.9	.75	.69	1.10	2.01	.75	.69	1.63	.60	1.38	2.34
4	4	2	2	6-1/4	1021700	2.9	.75	.81	1.66	2.56	.88	.75	2.13	.69	1.62	2.46
5 & 6	6	3	2	8-1/2	1021709	5.1	1.00	.94	2.47	3.50	1.00	.88	3.13	.88	1.88	2.84

\* Designed for use with Type III, (Eye & Eye), Class 7, 2 Ply web slings. For 3" and larger webbing width, tapered eye is required. † Maximum Proof Load is 2 times the Working Load Limit.



# Sling Saver® Web Sling Shackles



**S-281**

Web Sling Shackle is designed to connect Synthetic Web Slings and Synthetic Round Slings to eyebolts, pad eyes, and lifting lugs.

- All Alloy Construction.
- Design Factor of 5:1.
- Each shackle has a Product Identification Code (PIC) for material traceability along with a Working Load Limit and the name Crosby forged into it.
- Incorporates same ear spread and pin dimensions as conventional Crosby Shackles. Allows easy connection to pad eyes, eye bolts, and lifting lugs.
- Increased radius of bow gives wider sling bearing surface resulting in an increased area for load distribution, thus:
  - Increasing Synthetic Sling efficiency as compared to standard anchor and chain shackle bows and conventional eye hooks. This allows 100% of the sling's rated Working Load Limit to be achieved.
  - Allows better load distribution on internal fibers.
- Meets or exceeds all requirements of ASME B30.26 including identification, ductility, design factor, proof load and temperature requirements. Importantly, these shackles meet other critical performance requirements including fatigue life, impact properties and material traceability, not addressed by ASME B30.26.
- Look for the Red Pin® ... The mark of genuine Crosby Quality.

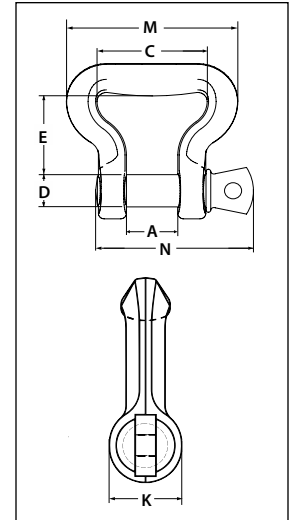

Sling Saver Fittings



Crosby Sling Saver hardware meets the requirements for minimum stock diameter or thickness, and effective contact width shown in the Recommended Standards Specification for Synthetic Polyester Round Slings by the Web Sling & Tie Down Association. WSTDA-RS1.

## S-281 Web Sling Shackle

Round Sling Size (No.)	Web Slings*			Working Load Limit (Tons)†	S-281 Stock No.	Weight Each (lb)	Dimensions (in)						
	Webbing Width (in)	Eye Width (in)	Ply				A	C	D	E	K	M	N
1 & 2	2	2	2	3-1/4	1021048	1.2	1.06	2.50	.75	1.62	1.22	3.84	3.34
3	3	1.5	2	4-1/2	1021057	1.5	1.25	2.00	.88	1.50	1.41	3.38	3.97
4	4	2	2	6-1/4	1021066	2.5	1.44	2.50	1.00	2.00	1.62	4.22	4.50
5 & 6	6	3	2	8-1/2	1021075	4.3	1.69	3.62	1.13	2.75	1.84	5.64	5.13

\* Designed for use with Type III, (Eye & Eye), Class 7, 2 Ply web slings. For 3" and larger webbing width, tapered eye is required. † Maximum Proof Load is 2 times the Working Load Limit.

### Web Slings vs. Roundslings

**Web Slings** are flexible, lightweight, and have a flat construction, normally with eyes at both ends. The flexibility of the sling helps to reduce shock loading effects. It is also important to note that the load-bearing yarns of the sling come in direct contact with the load. **Roundslings** are a continuous loop of yarn covered by a woven tubular casing. This casing comes in direct contact with the load, which helps to protect the load-bearing yarns inside. **Whether Web or Round, rest assured that the Crosby Sling Saver® product line offers the fittings you need to get the most out of your slings in the toughest lifting applications and environments.**



# Sling Saver® Web Sling Shackles



**S-252  
BOLT TYPE  
SLING SHACKLE**

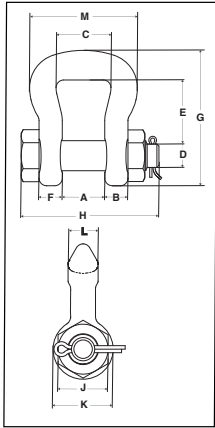

**S-253  
SCREW PIN  
SLING SHACKLE**

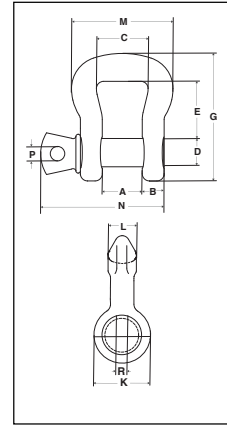

- Shackles available in size 3-1/4 to 50 metric tons.
- All Alloy construction.
- Design factor of 5:1.
- Each shackle has a Product Identification Code (PIC) for material traceability along with a Working Load Limit and the name Crosby forged into it.
- Increased radius of bow gives wider sling bearing surface resulting in an increased area for load distribution, thus:
  - Increasing Synthetic Sling efficiency as compared to standard anchor and chain shackle bows and conventional hooks. This allows 100% of the sling's rated Working Load Limit to be achieved.
  - Allows better load distribution on internal fibers.
- Meets or exceeds all requirements of ASME B30.26 including identification, ductility, design factor, proof load and temperature requirements. Importantly, these shackles meet other critical performance requirements including fatigue life, impact properties and material traceability, not addressed by ASME B30.26.
- Shackles available in both a Screw Pin and Bolt, Nut and Cotter Pin configuration.
- Bolt (Pin) has a larger diameter that provides better load distribution.
- Look for the Red Pin®... the mark of Genuine Crosby quality.



Crosby Sling Saver hardware meets the requirements for minimum stock diameter or thickness, and effective contact width shown in the Recommended Standards Specification for Synthetic Polyester Round Slings by the Web Sling & Tie Down Association. WSTDA-RS1.

## S-252 Bolt Type Sling Shackle

Web Sling Eye Width (in)	Round Sling Size (No.)	Working Load Limit (t)*	S-252 Stock No.	Weight Each (lb)	Dimensions (in)											
					A	B	C	D	E	F	G	H	J	K	L	M
1	1 & 2	3-1/4	1020485	1.4	1.06	.58	1.38	.75	1.50	.44	3.38	3.68	1.12	1.50	.75	2.69
1.5	3 & 4	6-1/2	1020496	2.4	1.25	.75	1.75	.88	1.88	.50	4.15	4.25	1.31	1.81	1.00	3.38
2	5 & 6	8-3/4	1020507	4.1	1.38	.88	2.25	1.00	2.81	.56	5.50	4.72	1.50	2.09	1.12	4.19
3	7 & 8	12-1/2	1020518	8.0	1.62	1.12	3.25	1.25	3.06	.75	6.34	5.88	1.88	2.62	1.38	5.62
4	9 & 10	20-1/2	1020529	16.9	2.12	1.38	4.50	1.50	5.25	.88	9.45	7.19	2.25	3.12	1.75	7.50
5	11 & 12	35	1020540	35.0	2.50	1.75	5.50	2.00	6.34	1.12	11.50	9.31	3.00	4.19	2.25	9.19
6	13	50	1020551	57.5	3.00	2.12	6.50	2.25	7.70	1.25	13.75	10.38	3.38	4.75	2.75	11.00

\* Maximum Proof Load is 2.5 times the Working Load Limit.

## S-253 Screw Pin Sling Shackle

Web Sling Eye Width (in)	Round Sling Size (No.)	Working Load Limit (t)*	S-253 Stock No.	Weight Each (lb)	Dimensions (in)											
					A	B	C	D	E	G	K	L	M	N	P	R
1	1 & 2	3-1/4	1020575	1.4	.88	.62	1.38	.75	1.50	3.38	1.50	.75	2.69	3.22	.44	1.00
1.5	3 & 4	6-1/2	1020584	2.2	1.25	.75	1.75	.88	1.88	4.15	1.81	1.00	3.38	4.03	.50	1.19
2	5 & 6	8-3/4	1020593	3.8	1.38	.88	2.25	1.00	2.81	5.50	2.09	1.12	4.19	4.50	.50	1.44
3	7 & 8	12-1/2	1020602	7.3	1.62	1.12	3.25	1.25	3.06	6.34	2.62	1.38	5.62	5.59	.62	1.81
4	9 & 10	20-1/2	1020611	15.2	2.12	1.38	4.50	1.50	5.25	9.45	3.12	1.75	7.50	6.88	.75	2.13
5	11 & 12	35	1020620	30.8	2.50	1.75	5.50	2.00	6.34	11.50	4.19	2.25	9.19	8.66	1.00	2.88
6	13	50	1020629	52.0	3.00	2.12	6.50	2.25	7.70	13.75	4.75	2.75	11.00	10.22	1.22	3.19

\* Maximum Proof Load is 2.5 times the Working Load Limit.

# Sling Saver® Shackles Accessories



**S-255 SPOOL**  
CE

## S-255 Spool

The "Spool" is designed to keep the load centered on the pin, thus keeping the sling positioned correctly in the shackle bow.

Working Load Limit (t)*	S-255 Stock No.	Weight Each (lb)	Dimensions (in)			
			A	B	C	D
3-1/4	1020903	.33	1.25	.81	.75	.19
6-1/2	1020912	.57	1.50	.94	1.00	.25
8-3/4	1020921	.89	1.75	1.05	1.19	.31
12-1/2	1020930	1.45	2.00	1.31	1.50	.38
20-1/2	1020939	2.79	2.50	1.63	1.88	.44
35	1020948	2.40	3.25	2.13	2.25	.50
50	1020957	4.06	3.75	2.38	2.75	.62

\* Maximum Proof Load is 2.5 times the Working Load Limit. Minimum Ultimate strength is 5 times the Working Load Limit.

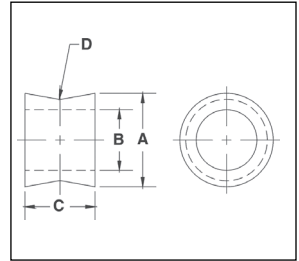

Sling Saver Fittings



**S-256 LINK PLATE**  
CE

## S-256 Link Plate

The "Link Plate" is designed to connect two (2) S-252 or S-253 "Sling Saver" Shackles together.

Working Load Limit (t)*	S-256 Stock No.	Weight Each (lb)	Dimensions (in)				
			A	B	C	D	E
3-1/4	1020785	.83	.75	1.50	3.38	.81	1.88
6-1/2	1020796	1.62	1.00	1.75	4.12	.94	2.25
8-3/4	1020807	2.71	1.25	2.00	4.75	1.06	2.62
12-1/2	1020818	5.18	1.50	2.50	6.00	1.31	3.37
20-1/2	1020829	8.19	1.75	3.00	7.00	1.62	3.75
35	1020840	17.19	2.00	4.00	9.25	2.12	5.00
50	1020851	37.40	2.88	5.00	10.50	2.38	5.75

\* Maximum Proof Load is 2.5 times the Working Load Limit. Minimum Ultimate strength is 5 times the Working Load Limit.

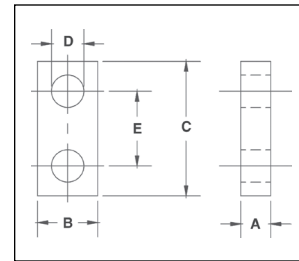

See page 105 for more information on the above products and how these products are integrated into synthetic sling systems.

**Sling Saver®**

## The Rigging Triangle

An important aspect of rigging safety is knowing how to form a rigging triangle. The rigging triangle is formed any time two or more slings are connected to a load and load hook. It is important to remember that as the rigging triangle becomes flatter, the horizontal sling angles become smaller, which increases sling tension. To avoid this, a **horizontal sling angle of 60 degrees or greater is considered optimal for all hitches**. At a 60 degree angle, the sling tension multiplier is only 1.15, the side or angular loading is limited, and the crushing load is 50 percent of the sling tension, which is considered minimal. **A helpful tip to verify that the slings are rigged at 60 degrees is to remember that a 60-degree sling angle is formed when an equilateral triangle is created.** This means that the sling length will be equal to the distance between pick points.





# Sling Saver® Synthetic Sling Hooks



**WSL-320A  
SYNTHETIC  
SLING HOOK**

- Hook capacities available: 1-1/2, 3, and 5 metric tons.
- All Alloy construction.
- Design factor of 5:1.
- Each hook has a Product Identification Code (PIC) for material traceability along with a working load limit and the name Crosby forged into it.
- Originally designed for 2-Ply Web slings, the Crosby Web Sling hook can also be used with Round Slings as long as the Working Load Limit ratings are compatible. The new hook incorporates the following features:
  - Eye is designed with a wide beam surface which:
    - Eliminates bunching effects.
    - Reduces sling tendency to slide.
    - Allows a better load distribution on internal fibers.
- All hooks feature Crosby's patented QUIC-CHECK® indicators.
- Hook Web Sling Eye width available: 1", 2", and 3".
- Fatigue rated to 20,000 cycles at 1-1/2 times the Working Load Limit.
- Includes S-4320 latch.

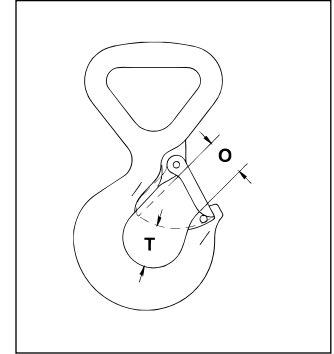
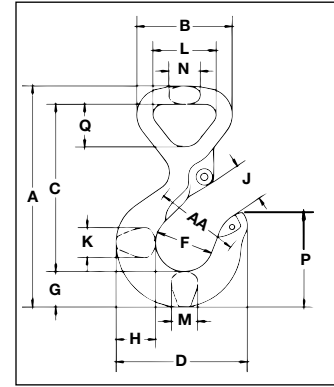

**Fatigue Rated** **Load Rated** **Sling Saver**



Crosby Sling Saver hardware meets the requirements for minimum stock diameter or thickness, and effective contact width shown in the Recommended Standards Specification for Synthetic Polyester Round Slings by the Web Sling & Tie Down Association. WSTDA-RS1.

## WSL-320A Synthetic Sling Hook

Web Sling Eye Width (in)	Round Sling Size (No.)	Working Load Limit (t)	WSL-320A with Latch	Weight Each (lb)	Hook I.D. Code	S-4320 Rep. Latch
1"	1	1-1/2	1022706	1.10	FA	1096374
2"	2	3	1022717	2.86	HA	1096468
3"	3	5	1022728	6.60	IA	1096515

## WSL-320A Synthetic Sling Hook

Hook ID Code	Working Load Limit (t)*	Dimensions (in)																
		A	B	C	D	F	G	H	J	K	L	M	N	O	P	Q	T	AA
FA	1-1/2	5.25	2.26	3.98	3.11	1.38	.84	.94	.93	.71	1.50	.63	.75	.91	2.24	1.01	.98	2.00
HA	3	7.11	3.66	5.31	3.97	1.63	1.13	1.32	1.13	.94	2.50	.85	1.13	1.09	2.82	1.69	1.16	2.00
IA	5	9.33	5.13	7.06	4.81	2.00	1.44	1.63	1.47	1.31	3.75	1.13	1.63	1.36	3.51	2.59	1.53	2.50

\* Maximum Proof Load is 2-1/2 times the Working Load Limit.

# Sling Saver® Fittings / Accessories



**S-287  
CHOKER HOOK**

- Available in 2 sizes: 3-1/4 Tons (2" webbing) and 4-1/2 Tons (3" webbing)
- Forged Alloy Steel – Quenched & Tempered
- Design factor of 5:1.
- Each Connector has a Product Identification Code (PIC) for material traceability along with a Working Load Limit and the name Crosby forged into it.
- Special design of hook protects the synthetic sling when dropped or dragged.
- Designed to reduce friction, abrasion, and fraying in choker area.
- Uses same spool and cover as S-280 Web Connector.  
Replacement Kit for Spool and Web Cover available.  
No retaining pin to snag sling material.

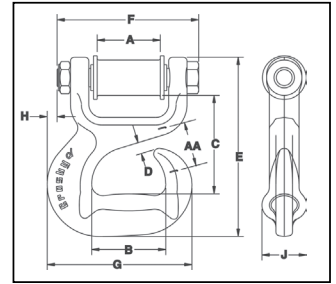

Sling Saver  
Fittings



Crosby Sling Saver hardware meets the requirements for minimum stock diameter or thickness, and effective contact width shown in the Recommended Standards Specification for Synthetic Polyester Round Slings by the Web Sling & Tie Down Association. WSTDA-RS1 (revised 2010)

## S-287 Sliding Choker Hook

Round Sling Size (No.)	Web Slings*			Working Load Limit (Tons) †	S-287 Stock No.	Weight Each (lb)	Dimensions (in)									
	Webbing Width (in)	Eye Width (in)	Ply				A	B	C	D	E	F	G	H	J	AA
1 & 2	2	2	2	3-1/4	1021909	3.7	2.13	2.50	3.32	.38	6.03	4.77	4.88	.34	1.50	1.50
3	3	1.5	2	4-1/2	1021918	6.1	1.63	3.50	3.67	.38	7.06	4.53	6.51	1.36	1.88	–

\* NOTE: Designed for use with Type III, (Eye & Eye), Class 7, 2 Ply web slings. † Maximum Proof Load is 2 times the Working Load Limit.

# Sling Saver® Synthetic Sling Connectors



**S-237**

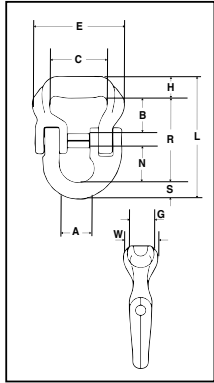

- High Performance Sling Connector is designed to connect to Slings of all materials.
- Capacities available:
  - Working Load Limit (5:1): 5,000 through 60,000 lbs.
  - Sling Body Widths: 2" through 6".
- Allows easy connection to master links or eye hooks, and is ideal for bridles.
- Increased radius of bow gives wider sling bearing surface resulting in an increased area for load distribution, thus:
  - Increasing Synthetic Sling efficiency as compared to master links, shackle bows and conventional eye hooks. This allows 100% of the sling's rated Working Load Limit to be achieved.
  - Allows better load distribution on internal fibers.
- All Alloy Construction
- Design Factor of 5:1.
- Individually Proof Tested at 2.5 times the Working Load Limit based upon 5:1 design factor.
- Each connector has a Product Identification Code (PIC) for material traceability, along with a frame size, and the name Crosby.



**S-238**

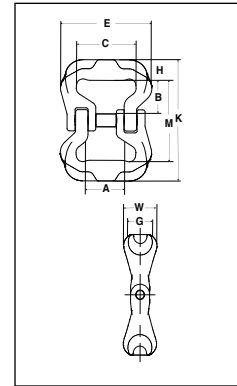

## S-237 High Performance Sling Connector

Working Load Limit		S-237 Web to Lok-A-Loy Assy. Stock No.	Frame No.	Nominal Sling Body Width (in)	Lok-A-Loy Size (in)	Weight Each (lb)	Dimensions (in)										
4:1 (lb)*	5:1 (lb)						A	B	C	E	G	H	L	N	R	S	W
6250	5000	1020695	5	2	3/8	1.14	.88	1.42	2.00	3.18	1.00	.80	4.20	1.04	2.92	.48	1.38
12500	10000	1020704	10	3	5/8	2.96	1.42	1.52	2.75	4.13	1.25	.98	5.68	1.71	3.94	.75	1.75
18750	15000	1020713	15	3	3/4	4.75	1.63	1.58	2.75	4.37	1.38	1.10	6.49	2.04	4.46	.93	1.88
31250	25000	1020722	25	4	7/8	8.59	2.00	2.33	3.75	6.00	1.75	1.41	7.97	2.27	5.51	1.06	2.25
37500	30000	1020731	30	4	7/8	9.24	2.00	2.20	3.75	6.19	1.75	1.41	7.84	2.27	5.38	1.06	2.38
50000	40000	1020740	40	5	1	15.7	2.25	2.91	4.75	7.25	2.25	1.78	9.45	2.44	6.45	1.22	3.09
75000	60000	1020759	60	6	1-1/4	26.0	2.56	3.36	5.75	9.13	2.31	1.86	11.08	3.07	7.72	1.50	3.16

\*Maximum allowable Proof Load is 2 times the Working Load Limit when used at 4:1 design factor.

## S-238 High Performance Sling Connector

Working Load Limit (lb)	S-238 Web to Web Assembly Stock No.	Frame No.	Nominal Sling Body Width (in)	Weight Each (lb)	Dimensions (in)									
					A	B	C	E	G	H	K	M	W	
5000	1020415	5	2	1.6	.88	1.42	2.00	3.18	1.00	.80	4.90	3.30	1.38	
10000	1020423	10	3	3.3	1.42	1.52	2.75	4.13	1.25	.98	5.72	3.76	1.75	
15000	1020432	15	3	4.9	1.63	1.58	2.75	4.37	1.38	1.10	6.16	3.96	1.88	
25000	1020441	25	4	10.1	2.00	2.33	3.75	6.00	1.75	1.41	8.40	5.58	2.25	
30000	1020450	30	4	11.4	2.00	2.20	3.75	6.19	1.75	1.41	8.14	5.32	2.38	
40000	1020469	40	5	20.7	2.25	2.91	4.75	7.25	2.25	1.78	10.48	6.92	3.09	
60000	1020478	60	6	32.0	2.56	3.36	5.75	9.13	2.31	1.86	11.72	8.00	3.16	

\*Maximum allowable Proof Load is 2.5 times the Working Load Limit. Minimum Ultimate strength is 5 times the Working Load Limit.



Crosby Sling Saver hardware meets the requirements for minimum stock diameter or thickness, and effective contact width shown in the Recommended Standards Specification for Synthetic Polyester Round Slings by the Web Sling & Tie Down Association. WSTDA-RS1.



# Sling Saver® High Performance Sling System



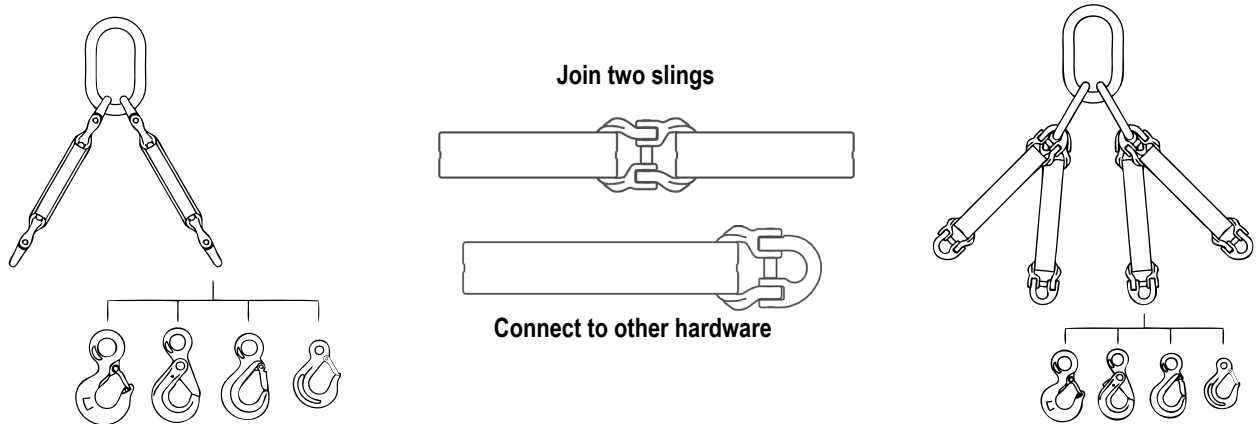

Sling Saver® Fittings

**Typical Application** The S-237 and S-238 connectors have been designed to easily adapt to other Crosby fittings to develop complete systems for high performance Synthetic Slings.

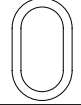
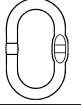

These easy-to-use charts are designed to allow you to quickly determine the Crosby Fitting required for your high performance sling.

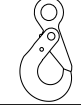

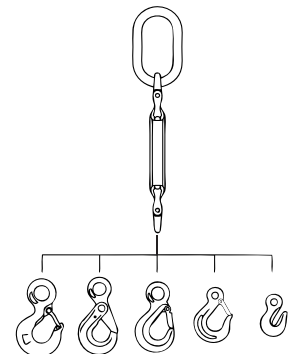

## Single Leg Sling

S-237 Frame	Working Load Limit (lb)*								
		A-1337 Lok-A-Loy (in)	A-342 (in)	A-344 (in)	(t)	Frame	S-1316 (in)	S-315A (in)	L-1327 (in)
5	5000	3/8	1	7/8	†7	JA	5/8	5/8	5/8
10	10000	5/8	1	7/8	†7	JA	5/8	5/8	5/8
15	15000	3/4	1-1/4	1	†11	KA	3/4	–	3/4
25	25000	7/8	1-1/2	1-1/4	†15	LA	7/8	–	7/8
30	30000	7/8	1-1/2	1-1/4	†15	LA	7/8	–	7/8
40	40000	1	1-3/4	–	†22	NA	1	–	–
60	60000	1-1/4	2	–	30	OA	–	–	–

\* Ultimate load is 5 times the Working Load Limit. † L-320AN Style Hook.

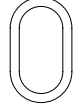
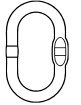

## Double Leg Sling

S-237 Frame	Working Load Limit (lb)*								
		A-1337 Lok-A-Loy (in)	A-342 (in)	A-344 (in)	(t)	Frame	S-1316 (in)	S-315A (in)	L-1327 (in)
5	5000	3/8	1-1/4	1-1/4	†7	JA	5/8	5/8	5/8
10	10000	5/8	1-1/4	1-1/4	†7	JA	5/8	5/8	5/8
15	15000	3/4	1-1/2	–	†11	KA	3/4	–	3/4
25	25000	7/8	1-3/4	–	†15	LA	7/8	–	7/8
30	30000	7/8	1-3/4	–	†15	LA	7/8	–	7/8
40	40000	1	2	–	†22	NA	1	–	–
60	60000	1-1/4	2-1/4	–	30	OA	–	–	–

\* Ultimate load is 5 times the Working Load Limit. † L-320AN Style Hook.

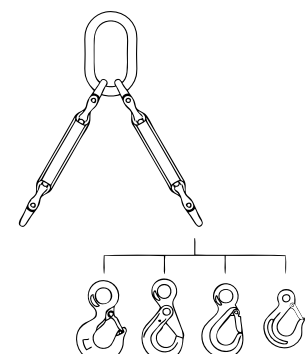

For Triple and Quad leg slings, contact Crosby Engineering at (918) 834-4611

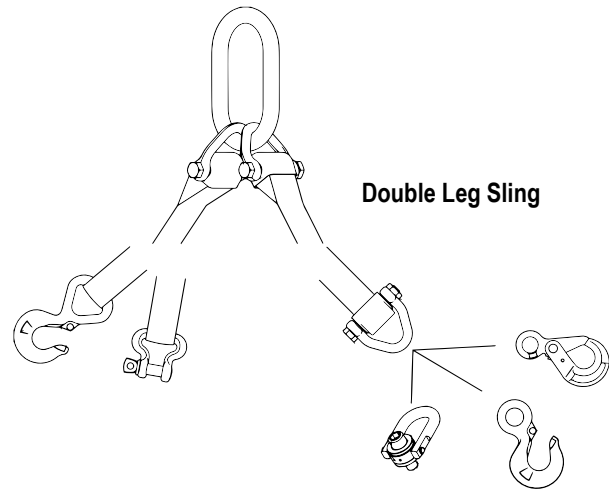
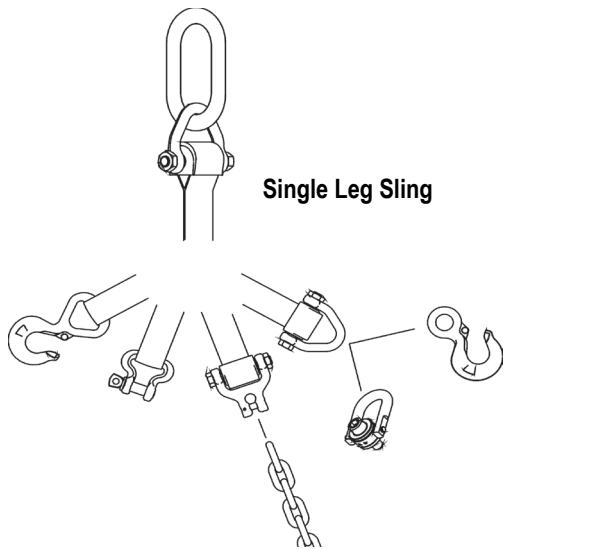

These easy-to-use charts are designed to allow you to quickly determine the fitting required to create the Web Sling or Round Sling you need.

## Single and Double Leg Slings Component Recommendations based on Type III, (Eye & Eye), Class 7, 2 Ply web slings.

S-280 Web Connector S-281 Web Sling Shackle					S-280 Web Connector							
Web Sling					Web Sling							
Round Sling Size (No.)	Web Width (in)	Eye Width (in)	Ply.	S-280 S-281 Working Load Limit (tons)	Web Sling Hook WSL-320 (t)	Spectrum 8° Chain Size (in) – (mm)	Eye Hoist Hook L-320AN (t)	Eye SHUR-LOC® S-1316A (in)	Swivel Hoist Ring HR-125 (lb)	Master Link A-342 Single Leg (in)	Master Link A-342 Double Leg (in)	
1 & 2	2	2	2	3-1/4	3	3/8 - 10	3	1/2	7,000	5/8	3/4	
3	3	1.5	2	4-1/2	5	1/2 - 13	5	5/8	10,000	3/4	1	
4	4	2	2	6-1/2	—	5/8 - 16	7	5/8	15,000	1	1	
5 & 6	6	3	2	8-1/2	—	—	11	—	24,000	1	1-1/4	

## Triple and Quad Leg Slings Component Recommendations based on Type III, (Eye & Eye), Class 7, 2 Ply web slings.

S-280 Web Connector S-281 Web Sling Shackle					S-280 Web Connector							
Web Sling					Web Sling							
Round Sling Size (No.)	Web Width (in)	Eye Width (in)	Ply.	S-280 S-281 Working Load Limit (tons)	Web Sling Hook WSL-320 (t)	Spectrum 8° Chain Size (in) – (mm)	Eye Hoist Hook L-320AN (t)	Eye SHUR-LOC® S-1316 (in)	Swivel Hoist Ring HR-125 (lb)	Master Link A-342 Triple Leg (in)	Master Link A-342 Quad Leg (in)	
1 & 2	2	2	2	3-1/4	3	3/8 - 10	3	1/2	7,000	1	1	
3	3	1.5	2	4-1/2	5	1/2 - 13	5	5/8	10,000	1	1-1/4	
4	4	2	2	6-1/2	—	5/8 - 16	7	5/8	15,000	1-1/4	1-1/2	
5 & 6	6	3	2	8-1/2	—	—	11	—	24,000	1-1/2	1-3/4	

## Easily Integrated into "Synthetic Sling System"



The "Synthetic Sling Saver" shackles line has been designed to easily adapt Crosby Sling fittings in the development of complete systems for synthetic slings.

### Single Leg Slings

Sling Saver Shackle							LOK-A-LOY® Link* A-1337				
Web Sling Eye Width (in)	Working Load Limit (T)	Sling Saver Shackle Spool S-255 (in)	Sling Saver Shackle Link Plate S-256 (in)	Eye Hoist Hook L-320AN† L-320A	Alloy Master Link A-342 (in)	Master Link Assy. A-345 (in)	Sling Hook L-1327 (in)	Eye Grab Hook A-1328 (in)	Eye Foundry Hook A-1329 (in)	Eye SHUR-LOC® S-1316A (in)	Eye Latching S-315A (in)
1	3-1/4	1	1	†5	3/4	—	3/8	3/8	3/8	3/8	3/8
1.5	6-1/2	1.5	1.5	†7	1	—	5/8	5/8	5/8	5/8	5/8
2	8-3/4	2	2	†11	1	—	5/8	5/8	5/8	5/8	5/8
3	12-1/2	3	3	†15	1-1/4	—	3/4	3/4	3/4	—	3/4
4	20-1/2	4	4	†22	1-3/4	—	—	3/4	—	3/4	—
5	35	5	5	37	2	—	—	3/4	—	—	—
6	50	6	6	60	2-1/4	—	—	3/4	—	—	—

\* LOK-A-LOY® size same as hook size. † New 320N Eye Hook.

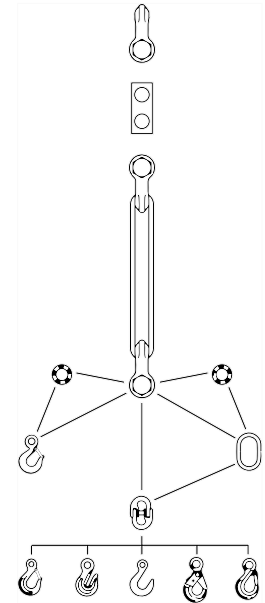

Single Leg Sling

Sling Saver Fittings

### Double Leg Slings

Sling Saver Shackle							LOK-A-LOY® Link* A-1337				
Web Sling Eye Width (in)	Working Load Limit (T)	Sling Saver Shackle Spool S-255 (in)	Sling Saver Shackle Link Plate S-256 (in)	Eye Hoist Hook L-320AN† L-320A	Alloy Master Link A-342 (in)	Master Link Assy. A-345 (in)	Sling Hook L-1327 (in)	Eye Grab Hook A-1328 (in)	Eye Foundry Hook A-1329 (in)	Eye SHUR-LOC® S-1316A (in)	Eye Latching S-315A (in)
1	3-1/4	1	1	†5	3/4	1	3/8	3/8	3/8	3/8	3/8
1.5	6-1/2	1.5	1.5	†7	1	1-1/4	5/8	5/8	5/8	5/8	5/8
2	8-3/4	2	2	†11	1	1-1/4	5/8	5/8	5/8	5/8	5/8
3	12-1/2	3	3	†15	1-1/4	1-1/2	3/4	3/4	3/4	—	3/4
4	20-1/2	4	4	†22	1-3/4	1-3/4	—	3/4	—	—	—
5	35	5	5	37	2	—	3/4	—	—	—	—
6	50	6	6	60	2-1/4	—	3/4	—	—	—	—

\* LOK-A-LOY size same as hook size. † New 320N Eye Hook.

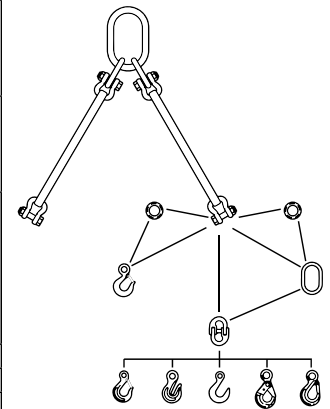

Double Leg Sling



**WEB SLINGS**

SHALL NOT BE CONSTRICTED OR BUNCHED BETWEEN THE EARS OF A CLEVIS OR SHACKLE, OR IN A HOOK.

**ROUND SLINGS**

SHALL NOT BE CONSTRICTED OR BUNCHED BETWEEN THE EARS OF A CLEVIS OR SHACKLE, OR IN A HOOK.

THE OPENING OF FITTINGS SHALL BE PROPER SHAPE AND SIZE TO ENSURE THAT THE FITTING WILL SEAT PROPERLY ON THE ROUND SLING.

WHEN A ROUND SLING IS USED WITH A SHACKLE, IT IS RECOMMENDED THAT IT BE USED (RIGGED) IN THE BOW OF THE SHACKLE.

**SYNTHETIC SLINGS RATED LOAD**

FOLDING, BUNCHING OR PINCHING OF SYNTHETIC SLINGS, WHICH OCCURS WHEN USED WITH SHACKLES, HOOKS OR OTHER APPLICATION WILL REDUCE THE RATED LOAD.

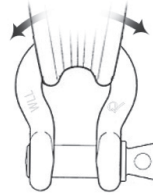

BUNCHING

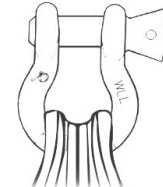

PINCHING

ASME B30.9



When connecting Web or Round Slings, use conventional fittings with:  
 1. Large Radius. 2. Straight Pins. 3. Pads or use special fittings designed for Synthetic Slings.

**SYNTHETIC SLING CONNECTIONS AND HITCHES**

**WEB SLING IDENTIFICATION INCLUDES:**

**SLING TYPE:**

- TC – TRIANGLE CHOKER
- TT – TRIANGLE TRIANGLE
- EE – EYE AND EYE
- EN – ENDLESS

**NUMBER OF PLYS:** 1 OR 2

**WEBBING GRADE:** 9 OR 6

**SLING WIDTH (INCH)**

**EE 2-9 04 x 12** ← **SLING LENGTH (INCH)**

**ROUND SLING IDENTIFICATION INCLUDES:**

**SLING NUMBER:** 1-13

SLING NUMBERS ARE FOR REFERENCE ONLY. SOME ROUND SLINGS HAVE DIFFERENT RATINGS.

**SLING COLOR:** PURPLE, GREEN, YELLOW, TAN, RED, WHITE, BLUE, ORANGE

SLING COLOR IS NOT FOLLOWED BY ALL MANUFACTURERS, AND SOME COLORS HAVE MORE THAN ONE RATED LOAD.

FOLDING, BUNCHING OR PINCHING OF SYNTHETIC SLINGS, WHICH OCCURS WHEN USED WITH SHACKLES, HOOKS OR OTHER APPLICATION WILL REDUCE THE RATED LOAD.

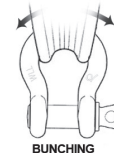

BUNCHING

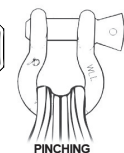

PINCHING

**CHOKER CAPACITY**

A CHOKER HITCH HAS 80% OF THE CAPACITY OF A SINGLE LEG SLING ONLY IF THE ANGLE OF CHOKE IS 120 DEGREES OR GREATER. A CHOKE ANGLE LESS THAN 120 DEGREES WILL RESULT IN A CAPACITY AS LOW AS 40% OF THE SINGLE LEG.

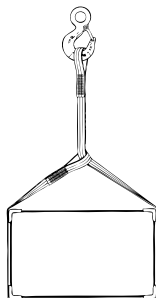

**BASKET HITCH CAPACITY**

HORIZONTAL ANGLE	CAPACITY % OF SINGLE LEG
90	200%
60	170%
45	140%
30	100%

A TRUE BASKET HITCH HAS TWICE THE CAPACITY OF A SINGLE LEG ONLY IF THE LEGS ARE VERTICAL.

**MULTIPLE LEG SLINGS**

TRIPLE LEG SLINGS HAVE 50% MORE CAPACITY THAN DOUBLE LEG SLINGS (AT SAME SLING ANGLE) ONLY IF THE CENTER OF GRAVITY IS IN CENTER OF CONNECTION POINTS AND LEGS ADJUSTED PROPERLY (THEY MUST HAVE AN EQUAL SHARE OF THE LOAD).

QUAD (4-LEG) SLINGS OFFER IMPROVED STABILITY BUT PROVIDE INCREASED CAPACITY ONLY IF ALL LEGS SHARE AN EQUAL SHARE OF THE LOAD.

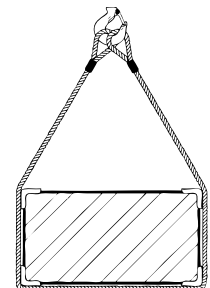

ALWAYS SELECT AND USE WEB SLINGS AND ROUND SLINGS BY THE RATED LOAD SHOWN ON THE SLING IDENTIFICATION TAG, NEVER BY WIDTH, COLOR OR SLING NUMBER.



# HOOKS & SWIVELS

With Product Warnings and Application Information





# "There is No Equal"

The Market Leader: Yesterday Today and Tomorrow



## Hooks & Swivels

### DESIGN

The theoretical reserve capability of a hoist hook should be a minimum of 5 to 1 for carbon eye hooks, alloy eye hooks and carbon shank hooks and 4.5 to 1 for alloy shank hooks. Known as the DESIGN FACTOR, it is usually computed by dividing the catalog ultimate load by the working load limit. The ultimate load is the average load or force at which the product fails or no longer supports the load. The working load limit is the maximum mass or force which the product is authorized to support in general service. The design factor is generally expressed as a ratio such as 5 to 1. Also important to the design of hooks is the selection of proper steel.

### THE COMPETITION

- Ask:** What is the the design factor?
- Ask:** Is production lot performance tested?



Crosby hoist hooks meet the design factor requirements of 5 to 1 for all carbon hooks, 5 to 1 for all alloy eye and swivel hooks and 4.5 to 1 for alloy shank hooks. Crosby's QC 1400 program determines the mechanical properties of each manufacturing lot of hoist hooks. In addition to the heat treat process, Crosby hooks are designed with a cross section that, when overloaded, allows uniform deformation and straightening before ultimate failure.

### QUENCHED AND TEMPERED

Quenching and tempering assures the uniformity of performance and maximizes the properties of the steel. This means that each hook meets its rated strength and other properties. This quenching and tempering process develops a tough material that reduces the risk of a brittle, catastrophic failure, thus improving impact and fatigue properties. As a result, if overloaded, the hook will deform before ultimate failure occurs, thus giving warning. The requirements of your job demand this reliability and consistency. Quench and Tempering insures that not only is the working load limit met, but that ductility, fatigue and impact properties are appropriate.

### THE COMPETITION

- Ask:** Are their hooks quenched and tempered?
- Ask:** Do their shackles have good fatigue life?
- Ask:** Do their shackles have a fatigue life that meets the new world standards?

Some competitors normalize the hooks, and as a result, desired properties are not achieved. A few even provide hooks in an "as forged" condition, which can result in brittle failure.



Crosby hoist hooks are quenched and tempered. This heat treatment process assures a hook that will deform prior to ultimate failure. Impact and fatigue properties are superior with quenched and tempered hooks. Crosby's Quenched and Tempered carbon and alloy hoist hooks are recommended for all critical applications, including overhead lifting.



### FULL LINE AND IDENTIFICATION

The proper application of hoist hooks requires that the correct type, size, and working load capacity of hook be used. All hooks must be load rated (with either the working load or a cross reference code). In addition the traceability code, size, and manufacturer's name should be boldly marked on the product. Availability of a full line of eye, shank, and swivel hooks in carbon and alloy steel is essential when selecting the desired hook for the proper application.

### THE COMPETITION

- Ask:** Do they have a traceability system?
- Ask:** Does their traceability system tie into a comprehensive material testing program?
- Ask:** Does their product offering cover the full range?

Most competitors do not have the full line of hooks that Crosby produces. Most do not have a traceability system.



Crosby forges "Crosby" or "CG," the Product Identification Code (P.I.C.), and working load limit (or working load cross reference code) into its full line. Crosby's traceability system and P.I.C. are an integral part of the QC 1400 program.



### APPLICATION INFORMATION

Detailed application information will assist you in the proper selection and use of hoist hooks. This information is most effective when provided in supporting brochures and engineering information. A formal application and warning system that attracts the attention of the user, clearly informs the user of the factors involved in the task, and informs the user of the proper application procedures is needed.

### THE COMPETITION

- Ask:** Do they provide hook application and warning information attached directly to the hook?
- Ask:** What training support is provided?

Most competitors do not have a comparable product warnings system and application information for hoist hooks.



The Crosby Product Warnings System provides detailed application and warning information for hoist hooks. In addition, a video on hook maintenance is also available. Field inspection criteria and repair instructions are also available. Training seminars conducted by Crosby provide training on the proper use of hoist hooks. Crosby training packets, supplied free to attendees of Crosby's seminars, provide training materials needed to explain the proper use of hoist hooks.

**Remember: "When buying Crosby, you're buying more than product, you're buying Quality."**





## VALUE ADDED

- **U.S. ratings:** When comparing to other hooks which are rated in short tons, the design factor of Crosby hooks (in short tons) is 5 to 1 for all carbon hooks, 5 to 1 for alloy eye and swivel hooks, 4.5 to 1 for alloy shank hooks and 4 to 1 for all bronze hooks.
- **Application information:** Application and warning information is available for Crosby hoist hooks. The Crosby Warning System is designed to attract the attention of the user, clearly inform the user of the factors involved in the task, and provide the user with proper application procedures. Each Crosby hoist hook is tagged with appropriate application and warning information, thus insuring that the information is available at the point of application.
- **Charpy impact properties:** Crosby's quenched and tempered hooks have enhanced impact properties for greater toughness at all temperatures. Crosby can provide typical Charpy impact properties on selected sizes upon special request at the time of order.
- **Fatigue properties:** Typical fatigue properties are available for selected sizes. In addition, these properties will be provided upon special request for other sizes.
- **Ductility properties:** Crosby's QC 1400 program provides results of actual test values for ductility of the material. These results are measured by reduction of area and elongation. This is done for each production lot and is traceable by the Product Identification Code (PIC).
- **Tensile strengths:** Crosby's QC 1400 program provides hardness, tensile, and yield strength for each production lot of hoist hooks. They are traceable by the Product Identification Code (PIC).
- **Material Analysis:** Crosby can provide certified material (mill) analysis for each production lot, traceable by the Product Identification Code (PIC). Crosby, through its own laboratory, verifies the analysis of each heat of steel. Crosby purchases only *special bar* forging quality steel with specific cleanliness requirements and guaranteed hardenability.
- **Field inspection:** Written instructions for visual, magnaflux, and dye penetrant inspection of hooks are available from Crosby. In addition, acceptance criteria and repair procedures for hooks are available.
- **Proof testing:** If requested at the time of order, hooks can be furnished proof tested with certification. All SHUR-LOC® hooks (clevis and eye styles) are 100% proof tested with certificates.
- **Mag Certification:** If requested at the time of order, hooks can be Mag inspected with certification.
- **World Class Certification:** Certification to World Class Standards can be furnished upon request at the time of order. Specific standards include American Bureau of Shipping, Lloyds Register of Shipping, Det Norske Veritas, American Petroleum Institute, RINA, Nuclear Regulatory Commission, and other worldwide standards.
- **Bronze Hooks:** Crosby provides bronze shank hooks for non-sparking applications.
- **QUIC-CHECK®:** Hoist hooks incorporate markings forged into the product which address two (2) QUIC-CHECK® features: *Deformation Indicators:* Two strategically placed marks, one just below the shank or eye and the other on the hook tip, which allows for a QUIC-CHECK® measurement to determine if the throat opening has changed, thus indicating abuse or overload. *Angle Indicators:* Indicates the maximum included angle which is allowed between two (2) sling legs in the hook. These indicators also provide the opportunity to approximate other included angles between two sling legs.
- **McKissick Split-Nut Hook Retention System:** Shank hooks on crane blocks must be inspected in accordance with applicable ASME B30, CSA Z150 and other crane standards. These standards mandate the crane hook to be inspected for surface indications, damage and corrosion which could compromise the integrity of the crane block. Because of the type of environment in which these hooks are required to perform, the removal of corroded nuts from the threads can become a problem during inspections. The innovative patented McKissick Split-Nut Retention System is available on Crosby shank hoist hooks. With 4 easy steps, the hook can be disassembled, inspected and put back into service in a fraction of the time of a conventional threaded nut.

L-320N



319N



322N



L-1327



L-320



319



1316



Scan this QR code with your smart device to view our Split-Nut Retention System video.



**S-319/S-319N**

Trademark indicates  
QUIC-CHECK® product.  
Hook Material  
Codes: A-Alloy Steel,  
B-Bronze High Strength,  
C-Carbon Steel.

- The most complete line of shank marked hoist hooks. Available 3/4 to 300 metric tons.
- Hook Identification code marked into each hook
- All Carbon and Alloy Hooks are quenched and tempered.
- Quenched and Tempered.
- Available in carbon steel, alloy steel, and bronze.
- Proper design, careful forging, and precision controlled quench and tempering give maximum strength without excessive weight and bulk.
- Every Crosby Shank Hook has a pre-drilled cam which can be equipped with a latch. Simply purchase the latch assemblies listed and shown on pages 121 - 123. Even years after purchase of the original hook, latch assemblies can be added.
- Type Approval Certification in accordance with ABS 2016 Steel Vessels and ABS Guide for Certification on Cranes available. Certificates available when requested at time of order and may include additional charges
- Patented McKissick Split-Nut retention system available, see page 379 for more information.



**SEE APPLICATION AND WARNING INFORMATION**  
Crosby On Pages 142 - 143  
McKissick On Pages 144-145  
Para Español: [www.thecrosbygroup.com](http://www.thecrosbygroup.com)

**S-319 / S-319N Crosby® Shank Hook**

Working Load Limit (t)*			Hook ID Code	Shank Hooks Stock No.			Shank Length ‡	Weight Each (lb)	Rep. Latch Kits		
Carbon	Alloy	Bronze		Carbon S-319C S-319CN	Alloy S-319A S-319AN	Bronze S-319BN			S-4320 Stock No.	PL Stock No.	SS-4055 Stock No.
3/4	1	.5	†D	1028505	1028701	1028900	Std.	.50	1096325	-	-
1	1.5	.6	†F	1028514	1028710	1028909	Std.	.75	1096374	-	-
1-1/2	2	1	†G	1028523	1028723	1028918	Std.	1.00	1096421	-	-
2	3	1.4	†H	1028532	1028732	1028927	Std.	1.82	1096468	-	-
3	5	2	†I	1028541	1028741	1028936	Std.	3.69	1096515	1092000	-
5	7	3.5	†J	1028550	1028750	1028945	Std.	7.25	1096562	1092001	-
7-1/2	11	5	†K	1028563	1028765	1028954	Std.	13.4	1096609	1092002	-
10	15	6.5	†L	1028590	1028792	1028981	Std.	21.9	1096657	1092003	-
15	22	10	†N	1028599	1028801	1028990	Std.	38.4	1096704	1092004	-
20	30	-	O	1024386	1024803	-	Std.	72	-	1093716	1090161
20	30	-	O	1024402	1024821	-	Long	85	-	1093716	1090161
25	37	-	P	1024420	1024849	-	Std.	134	-	1093717	1090189
25	37	-	P	1024448	1024867	-	Long	172	-	1093717	1090189
30	45	-	S	1024466	1024885	-	Std.	182	-	1093718	1090189
30	45	-	S	1024484	1024901	-	Long	214	-	1093718	1090189
40	60	-	T	1024509	1024929	-	Std.	268	-	1093719	1090205
40	60	-	T	1024545	1024965	-	Long	312	-	1093719	1090205
50	75	-	U	1024563	1024983	-	Std.	390	-	1093720	-
50	75	-	U	1024581	1025009	-	Long	426	-	1093720	-
-	100	-	W	-	1025027	-	Std.	610	-	1093721	-
-	100	-	W	-	1025045	-	Long	675	-	1093721	-
-	150	-	X	-	1025063	-	Std.	735	-	1093721	-
-	200	-	Y	-	1025081	-	Std.	1020	-	1093723	-
-	300	-	Z	-	1025090	-	Std.	1390	-	1093724	-

Maximum allowable Proof Load is 2 Times Working Load Limit. All carbon hooks designed with a 5/1 design factor. All alloy hooks 1-22t designed with a 4.5/1 design factor. All alloy hooks 30t and larger designed with a 4/1 design factor. All bronze hooks designed with a 4/1 design factor. † New 319N style hook. ‡ See column "Y" on following page for actual length.

# Crosby® Shank Hooks



**S-319/S-319N**  
 Trademark indicates  
 QUIC-CHECK® product.  
 Hook Material  
 Codes: A-Alloy Steel,  
 B-Bronze High Strength,  
 C-Carbon Steel.

- Hoist hooks incorporate markings forged into the product which address two (2) QUIC-CHECK® features.
- **Deformation Indicators** -- Two strategically placed marks, one just below the shank or eye and the other on the hook tip, which allows for a **QUIC-CHECK®** measurement to determine if the throat opening has changed, thus indicating abuse or overload. To check, use a measuring device (i.e. tape measure) to measure the distance between the marks. The marks should align to either an inch or half-inch increment on the measuring device. If the measurement does not meet this criteria, the hook should be inspected further for possible damage.
- **Angle Indicators** -- Indicates the maximum included angle which is allowed between two (2) sling legs in the hook. These indicators also provide the opportunity to approximate other included angles between two sling legs.
- Chemical analysis and tensile tests performed on each PIC to verify chemistry and mechanical properties.



**SEE APPLICATION AND WARNING INFORMATION**  
 Crosby On Pages 142 - 143  
 McKissick On Pages 144-145  
 Para Español: www.thecrosbygroup.com

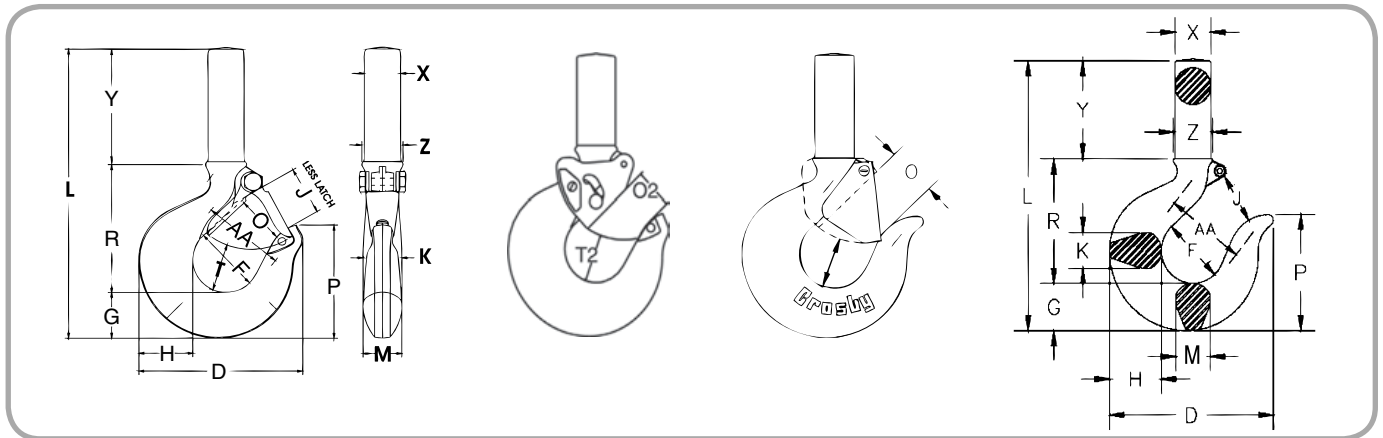

## S-319 / S-319N Crosby® Shank Hook

Hook ID Code	Dimensions (in)																	
	D	F	G	H	J	K	L	M	O	O2 ††	P	R	T	T2 ††	X	Y	Z	AA**
D	2.86	1.25	.73	.81	.93	.63	5.14	.63	.93 †	-	1.96	2.35	.97	-	.59	2.06	.69	1.50
F	3.16	1.38	.84	.94	.97	.71	5.68	.71	.97 †	-	2.22	2.59	.97	-	.76	2.25	.78	2.00
G	3.59	1.50	1.00	1.16	1.06	.88	6.35	.88	1.06 †	-	2.44	2.76	1.03	-	.72	2.59	.88	2.00
H	4.00	1.62	1.14	1.31	1.19	.94	7.14	.94	1.16 †	-	2.78	3.16	1.16	-	.88	2.84	1.00	2.00
I	4.84	2.00	1.44	1.63	1.50	1.31	8.63	1.13	1.36 †	1.00	3.47	3.85	1.53	1.50	1.16	3.44	1.25	2.50
J	6.28	2.50	1.82	2.06	1.78	1.66	10.43	1.44	1.61 †	1.31	4.59	4.77	1.96	1.88	1.41	3.84	1.56	3.00
K	7.54	3.00	2.26	2.63	2.41	1.88	12.52	1.63	2.08 †	1.81	5.25	5.88	2.47	2.25	1.81	4.38	1.94	4.00
L	8.34	3.25	2.60	2.94	2.62	2.19	16.10	1.94	2.27 †	2.00	5.96	6.37	2.62	2.31	2.00	7.00	2.19	4.00
N	10.34	4.25	3.01	3.50	3.41	2.69	18.15	2.38	3.02 †	2.75	6.88	8.14	2.83	2.56	2.56	7.00	2.63	5.00
O	13.62	5.00	3.62	4.62	4.00	3.00	23.09	3.00	3.25	-	8.78	9.44	3.44	-	3.12	10.00	3.12	6.50
O	13.62	5.00	3.62	4.62	4.00	3.00	31.09	3.00	3.25	-	8.78	9.44	3.44	-	3.12	18.00	3.12	6.50
P	14.06	5.38	4.56	5.00	4.25	3.62	32.12	3.00	3.00	-	11.31	12.50	3.88	-	4.00	15.00	4.00	7.00
P	14.06	5.38	4.56	5.00	4.25	3.62	41.12	3.00	3.00	-	11.31	12.50	3.88	-	4.00	24.00	4.00	7.00
S	15.44	6.00	5.06	5.50	4.75	3.72	34.12	3.25	3.38	-	12.56	14.00	4.75	-	4.19	15.00	4.19	8.00
S	15.44	6.00	5.06	5.50	4.75	3.72	43.12	3.25	3.38	-	12.56	14.00	4.75	-	4.19	24.00	4.19	8.00
T	18.50	7.00	6.00	6.50	5.75	4.44	36.06	3.91	4.12	-	14.75	15.56	5.69	-	4.50	14.50	4.50	10.00
T	18.50	7.00	6.00	6.50	5.75	4.44	47.56	3.91	4.12	-	14.75	15.56	5.69	-	4.50	26.00	4.50	10.00
U	20.62	7.75	6.69	7.25	6.50	5.25	41.16	4.25	4.88	-	16.53	19.38	6.00	-	5.00	15.00	5.00	11.50
U	20.62	7.75	6.69	7.25	6.50	5.25	49.16	4.25	4.88	-	16.53	19.38	6.00	-	5.00	23.00	5.00	11.50
W	23.00	6.81	8.59	9.88	5.88	5.50	42.12	5.50	4.50	-	17.25	18.41	7.00	-	7.00	15.00	7.00	12.00
W	23.00	6.81	8.59	9.88	5.88	5.50	48.12	5.50	4.50	-	17.25	18.41	7.00	-	7.00	21.00	7.00	12.00
X	24.38	6.75	9.12	10.94	6.00	6.00	45.75	6.00	4.50	-	18.00	18.38	7.00	-	7.25	18.00	7.25	13.00
Y	26.69	7.50	9.75	11.81	6.60	7.00	50.50	7.00	5.00	-	19.75	20.50	8.00	-	8.00	20.00	8.00	13.00
Z	30.12	9.50	10.62	12.94	8.00	7.25	54.69	8.00	6.25	-	22.69	23.50	8.25	-	9.50	20.00	9.50	15.00

Rough as-forged dimension. Shank will not machine to this dimension. Please refer to page 143 for recommended shank diameter when machining. \*\* Deformation Indicator. † 3/4" C - 22tA dimensions shown are for S-4320 Latch Kits. Dimensions for "O" frame size and larger are for PL Latch Kits. †† Dimensions are for PL-N latch kits. For the purpose of calculating D/d ratio, utilize dimension M.





**L-320CN  
EYE HOOK**



**L-320C  
EYE HOOK**

**All Crosby L-320 Eye Hoist Hooks incorporate the following features:**

- The most complete line of Eye hoist hooks.
- Available in carbon steel and alloy steel.
- Designed with a 5:1 Design Factor for (Carbon Steel); 4.5:1 Design Factor for 30t - 60t (Alloy Steel).
- Eye hooks are load rated.
- Proper design, careful forging and precision controlled quenched and tempering give maximum strength without excessive weight and bulk.
- Every Crosby Eye Hook is equipped with a latch. Even years after purchase of the original hook, latch assemblies can be added. (See pages 121 - 123)
- Chemical analysis and tensile tests performed on each PIC to verify chemistry and mechanical properties.
- Type Approval certification in accordance with ABS 2016 Steel Vessel and Guide for Certification of Lifting Appliances 2016 available. Certificates available when requested at time of order and may include additional charges.
- Meets ASME B30.10
- Hoist hooks incorporate two types of strategically placed markings forged into the product which address two (2) **QUIC-CHECK®** features:
- Deformation Indicators and Angle Indicators (see following page for detailed definition)

**The following additional features have been incorporated in the new Crosby L-320N Eye Hoist Hooks. (Sizes 3/4 metric ton Carbon through 22 metric ton Alloy.)**

- Metric Rated at 5:1 Design Factor for (Carbon Steel); 5:1 Design Factor for 1t - 22t (Alloy Steel).
- Can be proof tested to 2 times the Working Load Limit.
- Low profile hook tip
- New integrated latch (S-4320) meets the world-class standard for lifting.
  - Heavy duty stamped latch interlocks with the hook tip.
  - High cycle, long life spring.
  - When secured with proper cotter pin through the hole in the tip of hook, meets the intent of OSHA Rule 1926.1431(g) and 1926.1501(g) for personnel hoisting.



**L-320N / L-320 EYE HOOKS**

Working Load Limit (t)		Hook ID Code	Eye Hook Stock No.			Weight Each (lb)	Replacement Latch Kits		
Carbon	Alloy		Carbon L-320C L-320CN S.C.	Carbon GL-320CN Galv.	Alloy L-320A L-320AN S.C.		S-4320 Stock No.	PL Stock No.	SS-4055 Stock No.
3/4	1	†D	1022205	1022208	1022380	.61	1096325	-	-
1	1-1/2	†F	1022216	1022219	1022391	.89	1096374	-	-
1-1/2	2	†G	1022227	1022230	1022402	1.44	1096421	-	-
2	3	†H	1022238	1022241	1022413	2.07	1096468	-	-
3	5	†I	1022246	1022249	1022424	4.30	1096515	1092000	-
5	7	†J	1022260	1022262	1022435	8.30	1096562	1092001	-
7-1/2	11	†K	1022271	1022274	1022446	15.00	1096609	1092002	-
10	15	†L	1022282	1022285	1022457	20.77	1096657	1092003	-
15	22	†N	1022293	1022296	1022468	39.50	1096704	1092004	-
20	30	O	1022302	-	1022477	60.00	-	1093716	1090161
25	37	P	1023306	-	1023565	105.00	-	1093717	1090189
30	45	S	1023324	-	1023583	148.00	-	1093718	1090189
40	60	T	1023342	-	1023609	228.00	-	1093719	1090205

\*Eye Hooks (3/4 TC - 22TA), Proof load is 2 times Working Load Limit. Eye Hooks (20 TC - 60TA). All carbon hooks-average straightening load (ultimate load) is 5 times Working Load Limit. Alloy eye hooks 1 ton through 22 ton-average straightening load (ultimate load) is 5 times Working Load Limit. Alloy eye hooks 30 tons through 60 tons-average straightening load (ultimate load) is 4.5 times Working Load Limit. † New 320N style hook.

# Crosby® Eye Hooks



**L-320AN  
EYE HOOK**

- Hoist hooks incorporate markings forged into the product which address two (2) **QUIC-CHECK®** features.
- **Deformation Indicators** -- Two strategically placed marks, one just below the shank or eye and the other on the hook tip, which allows for a **QUIC-CHECK®** measurement to determine if the throat opening has changed, thus indicating abuse or overload. To check, use a measuring device (i.e. tape measure) to measure the distance between the marks. The marks should align to either an inch or half-inch increment on the measuring device. If the measurement does not meet this criteria, the hook should be inspected further for possible damage.
- **Angle Indicators** -- Indicates the maximum included angle which is allowed between two (2) sling legs in the hook. These indicators also provide the opportunity to approximate other included angles between two sling legs.

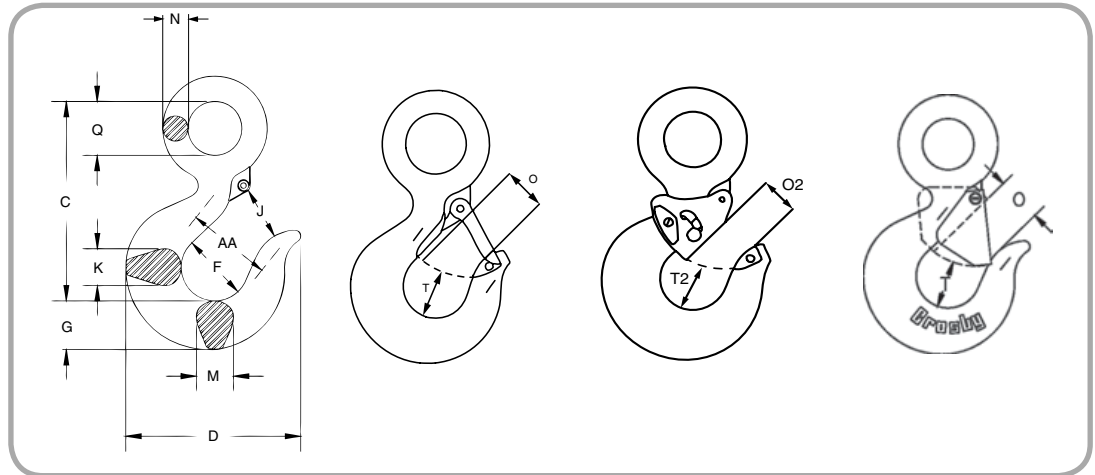

Hooks & Swivels

Load Rated®

Fatigue Rated®



**SEE APPLICATION AND WARNING INFORMATION**  
On Pages 144 - 145  
Para Español: [www.thecrosbygroup.com](http://www.thecrosbygroup.com)

## L-320N / L-320 EYE HOOKS

Hook ID Code*	Dimensions (in)													
	C	D	F	G	J	K	M	N	O †	O2 ††	Q	T †	T2 ††	AA**
D	3.34	2.83	1.25	.73	.90	.63	.63	.36	.89	-	.75	.87	-	1.50
F	3.81	3.11	1.38	.84	.93	.71	.71	.42	.91	-	.91	.98	-	2.00
G	4.14	3.53	1.50	1.00	1.00	.88	.88	.55	1.00	-	1.13	1.03	-	2.00
H	4.69	3.97	1.63	1.13	1.13	.94	.94	.58	1.09	-	1.25	1.16	-	2.00
I	5.77	4.81	2.00	1.44	1.47	1.31	1.31	.72	1.36	1.00	1.56	1.53	1.50	2.50
J	7.37	6.27	2.50	1.81	1.75	1.66	1.66	.90	1.61	1.31	2.00	1.96	1.88	3.00
K	9.07	7.45	3.00	2.25	2.29	1.88	1.63	1.11	2.08	1.81	2.44	2.47	2.25	4.00
L	10.08	8.30	3.25	2.59	2.50	2.19	1.94	1.27	2.27	2.00	2.84	2.62	2.31	4.00
N	12.53	10.30	4.25	3.00	3.30	2.69	2.38	1.56	3.02	2.75	3.50	2.83	2.56	5.00
O	14.06	13.62	5.00	3.62	4.00	3.00	3.00	1.75	3.25	-	3.50	3.44	-	6.50
P	18.19	14.06	5.38	4.56	4.25	3.75	3.19	2.00	3.00	-	4.50	3.88	-	7.00
S	20.12	15.44	6.00	5.06	4.75	4.50	3.25	2.18	3.38	-	4.94	4.75	-	8.00
T	23.72	18.50	7.00	6.00	5.75	5.50	3.91	2.53	4.12	-	5.69	5.69	-	10.00

\*Eye Hooks (3/4 TC-22TA), Proof load is 2 times Working Load Limit. Eye Hooks (20 TC-60TA). All carbon hooks - average straightening load (ultimate load) is 5 times Working Load Limit. Alloy eye hooks 1t through 22t - average straightening load (ultimate load) is 5 times Working Load Limit. Alloy eye hooks 30t through 60t - average straightening load (ultimate load) is 4.5 times Working Load Limit.

\*\* Deformation Indicators. † 3/4tC - 22tA dimensions shown are for S-4320 Latch Kits. Dimensions for "O" frame size and larger are for PL Latch Kits.

†† Dimensions are for PL-N latch kits.



**L-322CN / L-322AN**  
(L-322AN Shown)

- Forged - Quenched and Tempered.
- Swivel hooks are load rated.
- Proper design, careful forging, and precision controlled quench and tempering gives maximum strength without excessive weight and bulk.
- Low profile hook tip designed to utilize Crosby S-4320 or PL-N latch kit. Simply purchase the latch assemblies listed and shown on pages 121 - 122. Even years after purchase of the original hook, latch assemblies can be added.
- Hoist hooks incorporate markings forged into the product which address two (2) **QUIC-CHECK®** features:
  - **Deformation Indicators** -- Two strategically placed marks, one just below the shank or eye and the other on the hook tip, which allows for a QUIC-CHECK® measurement to determine if the throat opening has changed, thus indicating abuse or overload.
  - **Angle Indicators** — Indicates the maximum included angle which is allowed between two (2) sling legs in the hook. These indicators also provide the opportunity to approximate other included angles between two sling legs.
- Type Approval certification in accordance with ABS 2016 Steel Vessel Rules and ABS Guide for Certification of Lifting Appliances 2016 available. Certificates available when requested at time of order and may include additional charges.

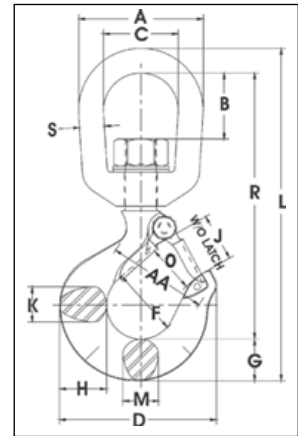

Load Rated

Fatigue Rated



**SEE APPLICATION AND WARNING INFORMATION**  
 On Pages 144 - 145  
 Para Español: [www.thecrosbygroup.com](http://www.thecrosbygroup.com)



*Suitable for infrequent, non-continuous rotation under load. Use in corrosive environment requires shank and nut inspection in accordance with ASME B30.10-1.10.4(b)(5)(c).*

**L-322CN & L-322AN Swivel Hooks**

Working Load Limit (t)*		Hook ID Code*	L-322CN Stock No.	L-322AN Stock No.	Weight Each (kg)	Dimensions (mm)														Rep. Latch Stock No.	
Carbon	Alloy					A	B	C	D	F	G	H	J	K	L	M	O †	R	S		AA**
.75	1.25	D	1048603	1048807	.34	51.0	20.8	31.8	72.5	31.8	18.5	20.6	23.6	16.0	144	16.0	23.6	116	9.65	38.1	1096325
1	1.60	F	1048612	1048816	.57	63.5	33.3	38.1	80.0	35.1	21.3	23.9	24.6	18.0	170	18.0	24.6	136	12.7	50.8	1096374
1.6	2.50	G	1048621	1048825	1.02	76.0	38.1	44.5	91.0	38.1	25.4	29.5	26.9	22.4	197	22.4	26.9	155	16.0	50.8	1096421
2	3.20	H	1048630	1048834	1.04	76.0	38.1	44.5	102	41.1	28.7	33.3	30.2	23.9	210	23.9	29.5	165	16.0	50.8	1096468
3.2	5.4	I	1048639	1048840	2.25	89.0	41.7	50.8	123	51.0	36.6	41.4	38.1	33.3	246	28.7	35.8	191	19.1	63.5	1096515
5	8.0	J	1048648	1048859	4.67	116	58.0	63.5	160	63.5	46.0	52.5	45.2	42.2	317	36.6	42.9	245	25.4	76.2	1096562
7.5	11.5	K	1048657	1048868	8.80	127	62.0	70.0	192	76.0	57.0	67.0	51.0	47.8	375	41.4	56.5	289	28.7	101	1096609
10	16	L	1048666	1048880	10.5	143	63.0	79.0	212	82.5	66.0	74.5	66.5	55.5	417	49.3	61.0	311	31.8	101	1096657
15	22	N	1048675	1048889	21.3	180	95.5	104	263	108	76.0	89.0	86.5	68.5	542	60.5	81.0	424	38.1	127	1096704
-	31.5	O	-	1048898	32.0	180	95.5	104	346	127	93.0	118	102	72.5	590	76.2	82.6	459	38.1	165	1090161

\* Carbon swivel hooks .75tC-15tC: proof load is 2 times working load limit. Designed with a 5 to 1 safety factor. Alloy swivel hooks 1tA - 30tA : proof load is 2.5 times working load limit. Designed with a 4 to 1 safety factor. Alloy swivel hook 30tA: proof load is 2 times working load limit. Designed with a 4 to 1 design factor. \*\* Deformation Indicators † Dimensions for hooks 3/4t carbon thru 22t alloy are for S-4320 latch kits. Dimensions for hooks 30t alloy are for 4055 latch kit.



# Crosby® Swivel Hooks



**L-3322B**  
Swivel Hooks  
with Bearing

**New anti-friction bearing design allows hook to rotate freely under load.**

- Capacities ranging from 2 through 15 metric tonnes.
- Forged - Quenched and Tempered.
- Proper design, careful forging, and precision controlled quench and tempering gives maximum strength without excessive weight and bulk.
- Low profile hook tip designed to utilize Crosby S-4320 or PL-N latch kit. Simply purchase the latch assemblies listed and shown on pages 121 - 123. Even years after purchase of the original hook, latch assemblies can be added.
- L-3322 hooks incorporate markings forged into the product which address two (2) **QUIC-CHECK®** features:
  - **Deformation Indicators** — Two strategically placed marks, one just below the shank or eye and the other on the hook tip, which allows for a QUIC-CHECK® measurement to determine if the throat opening has changed, thus indicating abuse or overload
  - **Angle Indicators** — Indicates the maximum included angle which is allowed between two (2) sling legs in the hook. These indicators also provide the opportunity to approximate other included angles between two sling legs.

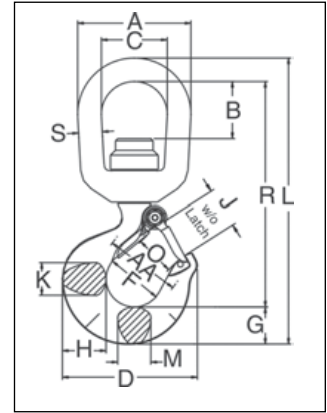

For other swivel hooks designed to rotate under load, see pages 117, 119, 120, 127, 128, 136-139. Use in corrosive environment requires shank and nuts inspection in accordance with ASME B30.10-1.10.4 (b)(5)(c).

## L-3322B Swivel Hooks with Bearing

Working Load Limit (t)*	Hook ID Code*	L-3322B Stock No.†	Weight Each (lb)	Dimensions (in)															Rep. Latch Stock No.
				A	B	C	D	F	G	H	J	K	L	M	O	R	S	AA**	
2	G	1028609	2.5	3.00	1.50	1.75	3.59	1.50	1.00	1.16	1.06	.88	7.64	.88	1.00	6.01	.63	2.00	1096421
3	H	1028618	3.8	3.50	1.56	2.00	4.00	1.62	1.13	1.31	1.19	.94	8.60	.94	1.09	6.72	.75	2.00	1096468
5	I	1028627	7.0	4.00	1.56	2.25	4.84	2.00	1.44	1.63	1.50	1.31	10.32	1.13	1.36	8.00	.88	2.50	1096515
7	J	1028636	14.0	5.00	1.94	2.75	6.27	2.50	1.81	2.06	1.78	1.66	12.84	1.44	1.61	9.90	1.13	3.00	1096562
11	K	1028645	22.3	5.62	2.05	3.12	7.54	3.00	2.25	2.63	2.41	1.88	15.24	1.63	2.08	11.74	1.25	4.00	1096609
15	L	1028654	36.0	7.12	3.62	4.10	8.33	3.25	2.59	2.94	2.62	2.19	18.64	1.94	2.27	14.41	1.50	4.00	1096657

\* Maximum allowable proof load is 2.5 times working load limit. Designed with a 4.5 to 1 design factor. \*\* Deformation Indicators. † Supplied with latch attached.



**S-1316**  
EYE HOOK



**S-1318A**  
SHANK HOOK

**All SHUR-LOC® hooks have the following features:**

- Forged Alloy Steel - Quenched and Tempered.
- Recessed trigger design is flush with the hook bod , protecting the trigger from potential damage.
  - Easy to operate with enlarged thumb access.
- Positive Lock Latch is Self-Locking when hook is loaded.
- The SHUR-LOC® hook, if properly installed and locked, can be used for personnel lifting applications and meets the intent of OSHA Rule 1926.1431(g)(1)(i)(A) and 1926.1501(g)(4)(iv)(B).
- Contact Engineered solutions for additional threading or Split Nut options to 1-800-777-1555.

**Eye Style incorporates these added features:**

- Individually Proof Tested to 2-1/2 times the Chain Working Load Limit with certification
- S-1316 meets the performance requirements of EN1677-3.
- 25% stronger than Grade 80.
- Suitable for use with Grade 100 and Grade 80 chain.
- Designed with “Engineered Flat” to connect to S-1325 chain coupler.

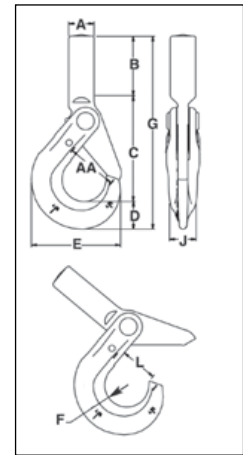
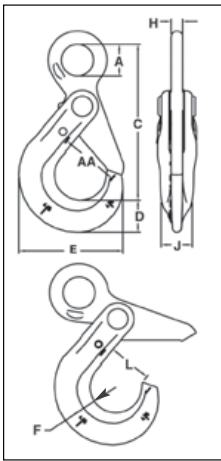

**S-1316 Eye Hook • SHUR-LOC® Hook Series with Positive Locking Latch**

Chain Size		Frame code	Grade 100 Alloy Chain Working Load Limit (lb)* 4:1	Working Load Limit (lb) 5:1	S-1316 Stock No.	Weight Each (lb)	Dimensions (in)								AA**
(in)	(mm)						A	C	D	E	F	H	J	L	
-	6	D	3200	2560	1022896	.85	.78	3.95	.79	2.60	.67	.31	.63	1.14	1.50
1/4-5/16	7-8	G	5700	4560	1022914	1.80	1.08	5.31	1.10	3.50	.87	.39	.81	1.48	2.00
3/8	10	H	8800	7040	1022923	3.40	1.30	6.57	1.17	4.39	1.10	.51	.94	1.83	2.50
1/2	13	I	15000	12000	1022932	6.00	1.65	8.23	1.67	5.45	1.26	.67	1.16	2.22	3.00
5/8	16	J	22600	18000	1022941	15.1	2.20	10.06	2.04	6.56	1.50	.87	1.50	2.65	3.50
3/4	18-20	-	35300	28240	1022942	19.0	2.60	10.77	2.22	7.76	2.01	.87	2.03	3.52	5.00
7/8	22	-	42700	34160	1022943	28.0	2.87	12.49	2.45	8.75	2.27	.98	2.20	3.83	6.00
1	26	-	59700	47760	1022944	49.5	3.15	14.60	3.21	9.87	2.46	1.26	2.68	4.09	6.50

\* Ultimate Load is 4 times the Working Load Limit based on Grade 100 chain. \*\* Deformation Indicators.

**S-1318A SHUR-LOC® Shank Hook**

Chain Size		S-1318A Stock No.	Frame code	Grade 100 Alloy Chain Working Load Limit (lb)	Dimensions (in)										Weight Each (lb)
(in)	(mm)				A†	B	C	D	E	F	G	J	L	AA**	
-	6	1098200	D	3200	.79	2.16	3.31	.79	2.60	.67	6.26	.63	1.16	1.50	1.00
1/4-5/16	7-8	1098209	G	5700	1.00	2.40	4.16	1.10	3.51	.87	7.66	.81	1.48	2.00	1.99
3/8	10	1098218	H	8800	1.14	2.95	5.14	1.17	4.39	1.10	9.26	.94	1.83	2.50	3.56
1/2	13	1098227	I	15000	1.34	3.35	6.31	1.67	5.49	1.26	11.33	1.16	2.22	3.00	7.00

\* Ultimate Load is 4 times the Working Load Limit based on Grade 100 chain. \*\* Deformation Indicators. † Dimension before machining (as forged).

# Crosby® SHUR-LOC® Hooks



**S-1326  
SWIVEL HOOK**

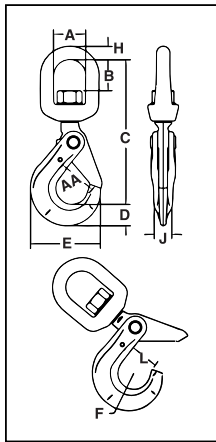

- Forged Alloy Steel - Quenched and Tempered.
- Individually Proof Tested at 2-1/2 times the Chain Working Load Limit with certification
- Recessed trigger design is flush with the hook bod , protecting the trigger from potential damage.
  - Easy to operate with enlarged thumb access.
- Positive Lock Latch is Self-Locking when hook is loaded.
- Rated for both Wire Rope and use with Grade 80/100 Chain or G-411 Standard Th
- G-414 Heavy Thimble or G-411 Standard Thimble should be used with wire rope slings.
- Trigger Repair Kit available (S-4316). Consists of spring, roll pin and trigger.
- S-13326 Swivel Hook utilizes anti-friction bearing design which allows hook to rotate freely under load.
- Fatigue rated.
- The SHUR-LOC® hook, if properly installed and locked, can be used for personnel lifting applications and meets the intent of OSHA Rule 1926.1431(g)(1)(i)(A) and 1926.1501(g)(4)(iv)(B).
- "Look for the Platinum Color – Crosby Grade 100 Alloy Products."



**S-13326  
SWIVEL HOOK  
with BEARING**

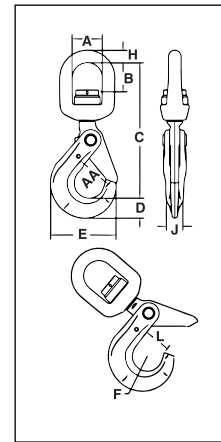

**SEE APPLICATION AND WARNING INFORMATION**  
On Pages 272 - 273  
Para Español: [www.thecrosbygroup.com](http://www.thecrosbygroup.com)

**Crosby 8/10™**

**QT**

**CE**

**Fatigue Rated**



Use in corrosive environment requires shank and nut inspection in accordance with ASME B 30.10-1.10.4 (b)(5)(c) 2019. The S-1326 hook is a positioning device and is not intended to rotate under load. For swivel hook designed to rotate under load, use the S-13326.

## S-1326 SHUR-LOC® Swivel Hooks • Suitable for infrequent, non-continuous rotation under load.

Chain Size		Frame code	Grade 100 Alloy Chain Working Load Limit (lb) 4:1*	Working Load Limit (lb) 5:1*	S-1326 Stock No.	Weight Each (lb)	Dimensions (in)									
(in)	(mm)						A	B	C	D	E	F	H	J	L	AA**
-	6	D	3200	2560	1004304	1.26	1.50	1.32	6.13	.79	2.60	.67	.50	.63	1.13	1.50
1/4 - 5/16	7-8	G	5700	4560	1004313	2.62	1.75	1.59	7.60	1.10	3.50	.87	.63	.81	1.38	2.00
3/8	10	H	8800	7040	1004322	4.70	2.00	1.73	8.83	1.17	4.39	1.10	.75	.94	1.75	2.50
1/2	13	I	15000	12000	1004331	8.64	2.50	2.38	11.20	1.67	5.45	1.26	1.00	1.16	2.11	3.00
5/8	16	-	22600	18000	1004340	17.00	2.75	2.70	12.90	2.05	6.56	1.50	1.13	1.50	2.49	3.50
3/4	18 - 20	-	35300	28240	1004349	24.00	2.83	2.52	14.10	2.22	7.76	2.01	1.10	2.03	3.52	5.00
7/8	22	-	42700	34160	1004358	29.00	3.44	3.19	16.40	2.45	8.75	2.26	1.30	2.20	3.83	6.00

\*Ultimate Load is 4 times the Working Load Limit. \*\* Deformation Indicators.

## S-13326 SHUR-LOC® Swivel Hooks with Bearing • Suitable for frequent rotation under load.

Chain Size		Frame code	Grade 100 Alloy Chain Working Load Limit (lb) 4:1*	Working Load Limit (lb) 5:1*	S-13326 Stock No.	Weight Each (lb)	Dimensions (in)									
(in)	(mm)						A	B	C	D	E	F	H	J	L	AA**
-	6	D	3200	2560	1004404	1.50	1.50	1.14	6.17	.79	2.60	.67	.50	.63	1.13	1.50
1/4 - 5/16	7-8	G	5700	4560	1004413	3.10	1.75	1.52	7.54	1.10	3.50	.87	.63	.81	1.44	2.00
3/8	10	H	8800	7040	1004422	5.26	2.00	1.61	8.88	1.16	4.35	1.10	.75	.94	1.83	2.50
1/2	13	I	15000	12000	1004431	11.22	2.50	2.03	11.11	1.66	5.45	1.26	1.00	1.16	2.19	3.00
5/8	16	-	22600	18000	1004440	17.32	2.75	2.25	12.90	2.05	6.56	1.50	1.13	1.50	2.61	3.50

\* Ultimate Load is 4 times the Working Load Limit. \*\* Deformation Indicators.



# Crosby® Grade 100 SHUR-LOC® Handle Hooks



**S-13326AH**  
SHUR-LOC® Handle Swivel Hook with Bearing



**S-1316AH**  
SHUR-LOC® Handle Eye Hook

- The SHUR-LOC® Handle Hook allows the user to get a confident grip on a load with ease and comfort.
- Designed with a handle opening big enough to comfortably fit a gloved hand.
- The replaceable pull-trigger allows the user to easily open the SHUR-LOC's positive self-locking latch.
  - Ergonomically designed for easy use and precise control.
  - Secondary side trigger is recessed to avoid inadvertent release.

**All SHUR-LOC® hooks have the following features:**

- Forged Alloy Steel - Quenched and Tempered.
- Positive Lock Latch is Self-Locking when hook is loaded.
- Individually Proof Tested at 2-1/2 times the Chain Working Load Limit with certification
- Rated for both Wire Rope and use with Grade 80/100 Chain.
- G-414 Heavy Thimble or G-411 Standard Thimble should be used with wire rope slings.
- S-13326 Swivel Hook utilizes anti-friction bearing design which allows hook to rotate freely under load.
- Fatigue rated.
- "Look for the Platinum Color – Crosby Grade 100 Alloy Products."
- The SHUR-LOC® hook, if properly installed and locked, can be used for personnel lifting applications and meets the intent of OSHA Rule 1926.1431(g)(1)(i)(A) and 1926.1501(g)(4)(iv)(B).
- Each SHUR-LOC® handle hook has a serial number.

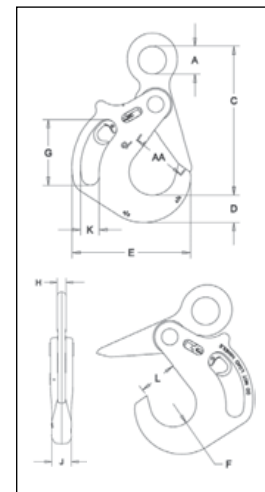
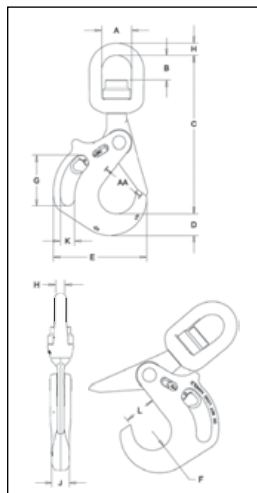

## S-13326AH SHUR-LOC® Handle Swivel Hooks with Bearings

Chain Size		Grade 100 Alloy Chain Working Load Limit (lb) 4:1*	Working Load Limit (lb) 5:1*	Frame Code	Stock No.	Weight Each (lb)	Dimensions (in)											
(in)	(mm)						A	B	C	D	E	F	G	H	J	K	L	AA**
5/8	16	22,600	18,080	JA	1005014	26	2.75	2.25	10.69	1.97	8.54	1.67	4.69	1.13	1.73	1.32	2.80	4.00
3/4	18/20	35,300	28,240	KA	1005023	37	3.12	2.04	15.49	2.60	10.03	1.99	4.72	1.25	2.05	1.26	3.31	5.00
7/8	22	42,700	34,160	LA	1005041	57	4.09	3.65	18.98	2.72	11.48	2.24	5.35	1.63	2.44	1.57	3.66	6.00
1	26	59,700	47,760	NA	1005050	84	5.00	4.02	21.55	3.11	12.77	2.52	6.46	1.63	2.76	1.57	4.09	6.50

\*Ultimate Load is 4 times the Working Load Limit. \*\* Deformation Indicators.

## S-1316AH SHUR-LOC® Handle Eye Hook

Chain Size		Grade 100 Alloy Chain Working Load Limit (lb) 4:1*	Working Load Limit (lb) 5:1*	Frame Code	Stock No.	Weight Each (lb)	Dimensions (in)											
(in)	(mm)						A	B	C	D	E	F	G	H	J	K	L	AA**
5/8	16	22,600	18,080	JA	1023579	18	2.01	10.69	1.97	8.54	1.67	4.69	0.79	1.73	2.80	4.00	2.80	4.00
3/4	18/20	35,300	28,240	KA	1023599	28	2.76	12.03	2.60	10.03	1.99	4.72	0.87	2.05	3.31	5.00	3.31	5.00
7/8	22	42,700	34,160	LA	1023607	39	3.15	13.46	2.72	11.48	2.24	5.35	3.58	2.44	3.66	6.00	3.66	6.00
1	26	59,700	47,760	NA	1023625	60	3.54	15.55	3.11	12.77	2.52	6.46	1.18	2.76	4.09	6.50	4.09	6.50

\*Ultimate Load is 4 times the Working Load Limit. \*\* Deformation Indicators.

# Crosby® Hook Latch Kits



**S-4320  
LATCH KITS**

- Heavy duty stamped latch interlocks with the hook tip.
- High cycle, long life spring.
- Can be made into a “Positive Locking” Hook when proper cotter pin is utilized.
- Latch kits shipped unassembled and individually packaged with instructions.
- Meets the intent of OSHA Rule 1926.1431(g) and 1926.1501(g) (when secured with the bolt, nut and pin) for lifting personnel.

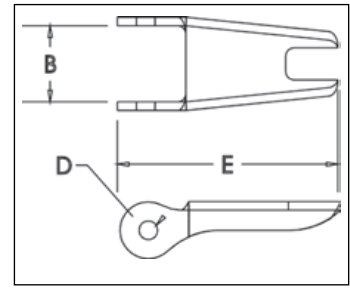

**IMPORTANT:** The new S-4320 Latch Kit will not fit the old style 319, 320 and 322 hooks.



Hooks & Swivels

## S-4320 Replacement Latch Kit for 319N, 320N, 322N, 339N, 1327 and 1339 Hooks

Hook Size (t)			Hook ID Code	S-4320 Stock No.	Weight Each (lb)	Dimensions (in)		
Carbon	Alloy	Bronze				B	D	E
3/4	1	.5	D	1096325	.03	.50	.15	1.44
1	1-1/2	.6	F	1096374	.04	.54	.17	1.56
1-1/2	2	1	G	1096421	.04	.63	.17	1.66
2	3	1.4	H	1096468	.06	.66	.17	1.91
3	5	2	I	1096515	.10	.83	.20	2.31
5	7	3.5	J	1096562	.15	1.04	.20	2.88
7-1/2	11	5	K	1096609	.28	1.25	.27	3.56
10	15	6.5	L	1096657	.33	1.35	.27	3.81
15	22	10	N	1096704	.84	1.66	.39	5.18

### Example of Hook ID Placement Location

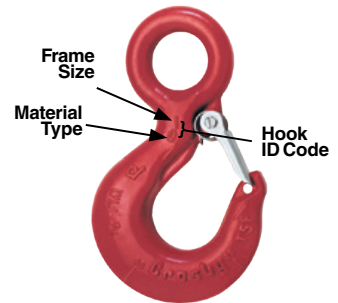

## IMPORTANT: Instructions for Assembling S-4320 Latch on Crosby 320N Hooks



**Step 1**

1. Place hook at approximately a 45 degree angle with the cam up.



**Step 2**

2. Position coils of spring over cam with legs of spring pointing toward point of hook and loop of spring positioned down and lying against the hook.



**Step 3**

3. Position latch to side of hook points. Slide latch onto spring legs between lockplate and latch body until latch is partially over hook cam. Then depress latch and spring until latch clears point of hook.

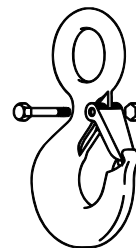

**Steps 4, 5, & 6**

4. Line up holes in latch with hook cam.  
5. Insert bolt through latch, spring, and cam.  
6. Tighten self-locking nut on one end of bolt.

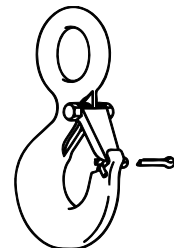

**Step 7**

**(For Personnel Lifting)**  
7. With latch in closed position and rigging resting in bowl of hook, insert cotter pin through hook tip and secure by bending prongs.

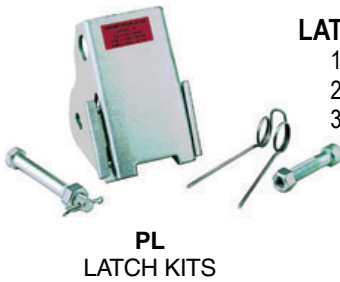

**PL  
LATCH KITS**

### LATCH ORDERING INSTRUCTIONS

1. Specify PL, PL-N or PL-O latch kit stock number from charts below.
2. Specify capacity of hook to which latch will be assembled.
3. Specify hook material (carbon or alloy).



The PL latch will not work on 319N, 320N or 322N hooks. The PL-N/O latches, in the sizes available, will work on both the old and new style hooks.



- Hot dip galvanized.
- Heavy duty latch with easy operating features.
- Flapper lever indicates locked or unlocked position.
- Assembly instructions included with each latch.
- For additional dimensional data on eye, shank or swivel hooks refer to pages 114 through 122 in this section.
- Meets the intent of OSHA Rule 1926.1431(g) and 1926.1501(g) (when secured with the bolt, nut and pin) for lifting personnel.

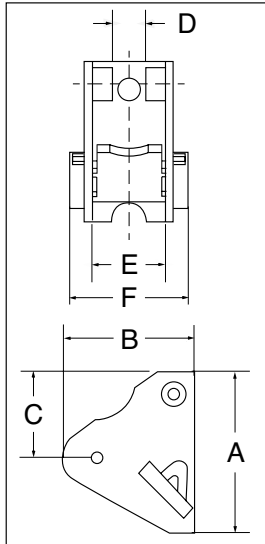

### PL LATCH KITS

Hook Size (t)		Hook ID Code	PL Latch Kit Stock No.	Weight Each (lb)	Dimensions (in)					
Carbon	Alloy				A	B	C	D	E	F
3	4-1/2	I	1093711	.54	2.57	2.34	1.94	.56	1.13	2.00
5	7	J	1093712	.66	3.00	2.34	2.00	.63	1.38	2.22
7-1/2	11	K	1093713	1.00	3.63	2.77	2.38	.63	1.63	2.38
10	15	L	1093714	1.25	4.00	3.22	2.69	.63	1.88	3.38
15	22	N	1093715	2.96	5.31	4.00	2.91	.84	2.38	3.44
20	30	O	1093716	4.05	6.00	4.44	3.19	1.06	2.88	4.25
25	37	P	1093717	8.63	7.00	6.63	4.06	2.24	4.50	6.12
30	45	S	1093718	10.00	6.75	7.00	4.03	2.24	4.75	6.38
40	60	T	1093719	14.30	8.00	7.66	4.38	3.46	5.50	7.25
50	75	U	1093720	27.00	9.88	8.19	5.13	3.38	6.50	8.88
-	100-150	W - X	1093721	33.25	10.88	11.06	6.38	3.38	7.50	10.00
-	200	Y	1093723	45.00	11.88	11.19	6.38	3.38	8.75	11.25
-	300	Z	1093724	55.00	12.50	12.19	8.00	3.38	9.75	13.00



**PL-N/O  
LATCH KITS**

### LATCH ORDERING INSTRUCTIONS

1. Specify PL, PL-N or PL-O latch kit stock number from charts below.
2. Specify capacity of hook to which latch will be assembled.
3. Specify hook material (carbon or alloy).



- Heavy duty latch with easy operating features.
- PL-N designed for Crosby 319N & 320N style hooks, PL-O designed for Crosby 319 & 320 old style hooks.
- Flapper lever indicates locked or unlocked position.
- Assembly instructions included with each latch.
- For additional dimensional data on eye, shank or swivel hooks refer to pages 114 through 122 in this section.
- Meets the intent of OSHA Rule 1926.1431(g) and 1926.1501(g) (when secured with the supplied toggle pin) for lifting personnel

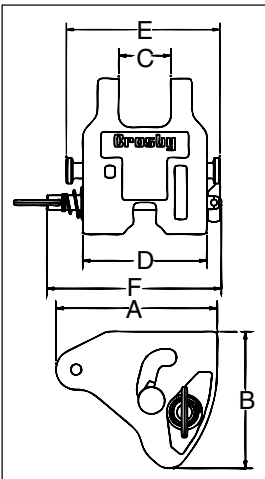

### PL-N/O LATCH KITS

Hook Size (t)		Hook ID Code	PL-N Latch Kit	PL-O Stock No.	Weight Each (lb)	Dimensions (in)					
Carbon	Alloy					A	B	C	D	E	F
3	4.5 / 5 *	I	1092000	1091900	.8	2.40	2.01	.83	2.13	2.71	3.44
5	7	J	1092001	1091901	1.3	2.94	2.50	1.00	2.52	3.19	3.83
7-1/2	11	K	1092002	1091902	2.0	3.63	3.02	1.19	2.75	3.44	4.38
10	15	L	1092003	1091903	2.8	4.00	3.39	1.34	3.19	4.00	4.50
15	22	N	1092004	1091904	4.9	5.19	4.32	1.61	3.86	4.81	5.13

\*N style hooks are rated at 5 tonnes.



# Crosby® Hook Latch Kits



## LATCH ORDERING INSTRUCTIONS

1. Specify latch kit stock number.
2. Specify capacity of hook to which latch will be assembled.
3. Specify hook material (carbon or alloy).



*These latches will not work on new "N" style hooks.*

- Stainless steel construction with cadmium plated steel nuts.
- Shipped packaged and unassembled.
- Instructions included for easy field assembly.



## SS-4055 LATCH KITS

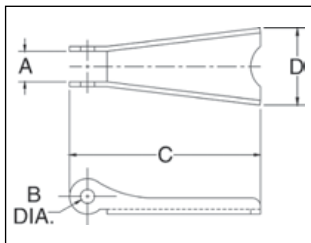

Hook Size (t)			Hook ID Code	SS-4055 Stock No.	Weight Each (lb)	Dimensions (in)			
Carbon	Alloy	Bronze				A	B	C	D
3/4	1	.5	D	1090027	.02	.38	.16	1.44	.59
1	1-1/2	.6	F	1090045	.02	.38	.16	1.60	.59
1-1/2 - 2	2 - 3	1.0 - 1.4	G / H	1090063	.03	.47	.19	1.84	.82
3	4-1/2	2.0	I	1090081	.06	.56	.17	2.41	1.00
5	7	3.5	J	1090107	.11	.58	.20	2.97	1.21
7-1/2 - 10	11 - 15	5.0 - 6.5	K / L	1090125	.17	.59	.27	3.66	1.50
15	22	10.0	N	1090143	.39	.83	.39	4.94	1.90
20	30	--	O	1090161	.63	.94	.52	5.88	2.56
25 - 30	37 - 45	--	P / S	1090189	1.12	2.19	.39	6.50	3.84
40	60	--	T	1090205	1.77	3.31	.52	7.88	4.12



## LATCH ORDERING INSTRUCTIONS

1. Specify latch kit stock number.
2. Specify capacity of hook to which latch will be assembled.
3. Specify hook material (carbon or alloy).

- To be used on A-327 and A-339 Grade 8 Sling Hooks.
- Latch Kits shipped unassembled and individually packaged with instructions.

## S-4088 LATCH KITS

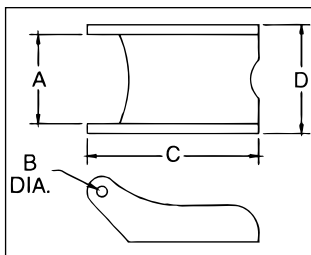

Hook Chain (in)	S-4088 Stock No.	Weight Each (lb)	Dimensions (in)			
			A	B	C	D
9/32 (1/4)	1090250	.06	.78	.16	2.03	.94
3/8	1090251	.14	1.03	.19	2.69	1.25
1/2	1090252	.15	1.03	.19	3.00	1.25
5/8	1090253	.15	1.03	.19	3.25	1.25
3/4	1090254	.15	1.53	.26	4.13	1.88
7/8	1090255	.15	1.53	.26	4.66	2.00

**HOOK CONNECTORS**

The 5 connector styles shown below make it possible for Crosby to furnish a Golden Gate Hook to fit almost any make or model of hoisting equipment including American Engineering Lo-Hed, ARO, Coffing, Electro Lift, Ingersoll-Rand, & H, Robbins and Myers, Shepard Niles, CM, Shaw-Box, Wright, Yale & Towne.

**CLOSED SWIVEL BAIL**

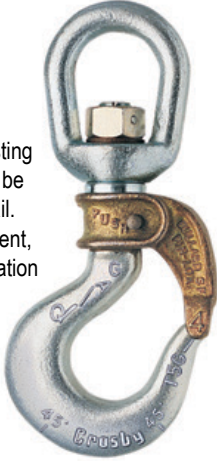

For use where hoisting line or shackle can be inserted into the bail. Suitable for infrequent, non continuous rotation under load. Hook sizes: 1 through 14.

**Style C** — with self-closing gate.  
**Style A** — with manual-closing gate.

**SHANK-TYPE HOOK**  
(Standard Length)

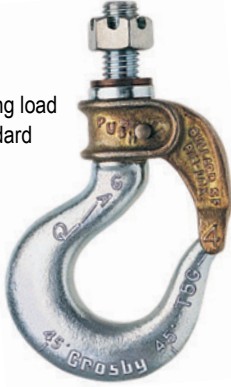

For use on existing load blocks, with standard shank length. Hook sizes: 2 through 14.

**Style D** — with self-closing gate.  
**Style B** — with manual-closing gate.

**SHANK-TYPE HOOK**  
(Long Length)



For use on existing load blocks requiring extra shank length. Hook sizes: 4 through 17.

**Style K** — with self-closing gate.  
**Style I** — with manual-closing gate.

**UNIVERSAL TYPE**

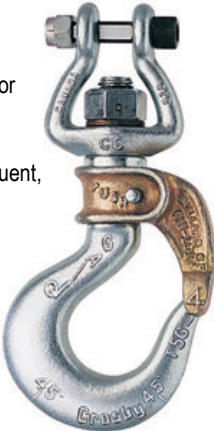

Open swivel bail for attachment to link chain. Suitable for infrequent, non continuous rotation under load. Hook sizes: 3, 4 and 5.

**Style E** — with self-closing gate.  
**Style G** — with manual-closing gate.

**LINK CHAIN NEST**



With ball-bearing swivel; attaches to chain by an alloy pin. Suitable for frequent rotation under load. Hook sizes: 4, 5 and 7.

**Style O** — with self-closing gate.  
**Style P** — with manual-closing gate.

Letter designations shown beneath each illustration above indicate BOTH connector style and gate type. Each connector is available with either a self-closing or manual-closing gate. (e.g.: A size 4 hook with a closed swivel bail connector and self-closing gate is 4-C; with manual-closing gate, it is 4-A.)

# Crosby®/ Bullard® Golden Gate® Hooks

## GATE TYPES

Brass alloy Golden Gates® are engineered for quality, easy handling and dependability. The heavy duty, corrosion resistant locking mechanism will stay locked until an operator releases it; yet, can easily be shut with one hand. Cost effective, these gates reduce down time, providing the alternative to conventional latches.

### LIF-LOK® GATE - SIZE 1

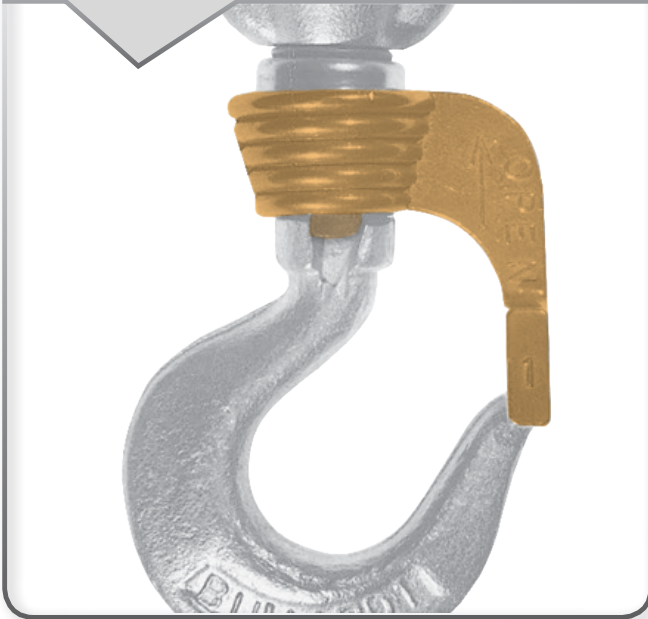

**To Lock:** Close the gate; the built-in spring locks the gate against the hook tip.  
**To Unlock:** Lift the gate upward on the hook shank and swing open.

### ROLLOX® GATE - SIZE 5 through 9



**To Lock:** Close the gate; a stainless steel pin is mounted in a horizontal bore which passes through the gate and engages a notch milled in the hook shank.  
**To Unlock:** Move the lever downward a quarter-turn or until it stops, the gate can now swing open 160° (approx.)

### PIN-LOK® GATE - SIZE 2 through 4



**To Lock:** Close the gate; a stainless steel pin is carried in a horizontal bore and engages a milled slot in the hook shank.  
**To Unlock:** Simply depress the stainless steel pin which causes the pin to disengage from the milled slot.

### TIP-LOK® GATE - SIZE 10 through 17



**To Lock:** Press the arm down until the lock trips; two arms of the gate now enclose the tip of the hook.  
**To Unlock:** Manually depressing the locking trigger automatically raises the movable arm, allowing the gate to be rotated open.





Closed Swivel Bail

- For use where hoisting line or shackle can be inserted into the bail.
  - **BL-D** - with self-closing gate.
  - **BL-B** - with manual-closing gate.
- Suitable for infrequent, non-continuous rotation under load.
- Use in corrosive environment requires shank and nut inspection in accordance with ASME B30.10-1.10.4(b)(5)(c).
- Crosby®/Bullard® Hooks incorporate two types of strategically placed markings forged into the product which address two (2) **QUIC-CHECK®** features:
  - Angle Indicators and Deformation Indicators (see the Bullard® **QUIC-CHECK®** table at bottom of page 129 for detailed definition)

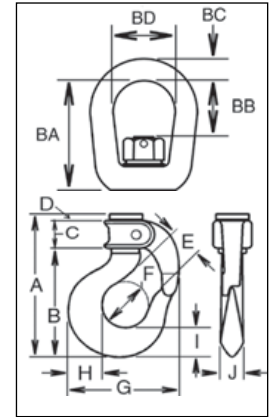

Closed Swivel Bail

Hook Size	BL-C Stock No.	BL-A Stock No.	Gate Type	Working Load Limit (T)*	Weight Each (lb)	Dimensions (in)													
						A	B	C	D	E	F	G	H	I	J	BA	BB	BC	BD
1	1050210	1050001	LIF-LOK	.50	0.8	3.23	2.31	.63	.26	.69	.88	2.25	.69	.63	.44	1.75	.63	.31	1.00
2	1050221	1050012	PIN-LOK	1.00	1.3	4.12	3.00	.93	.16	.97	1.25	2.88	.81	.75	.56	1.86	.95	.38	1.25
3	1050232	1050023	PIN-LOK	1.40	1.9	4.50	3.31	.94	.22	1.06	1.38	3.19	.94	.84	.63	2.44	1.31	.50	1.50
4	1050243	1050034	PIN-LOK	1.70	2.2	4.88	3.63	1.00	.22	1.13	1.50	3.63	1.16	1.00	.75	2.66	1.35	.50	1.50
5	1050254	1050045	ROLLOX	2.30	3.8	5.63	4.12	1.23	.25	1.25	1.64	4.09	1.31	1.12	.84	2.91	1.60	.63	1.75
6	1050265	1050056	ROLLOX	4.00	4.6	6.23	4.70	1.25	.25	1.39	1.64	4.56	1.57	1.34	.97	3.10	1.41	.63	1.75
7	1050276	1050067	ROLLOX	4.20	6.9	6.61	5.21	1.12	.25	1.50	2.00	4.94	1.63	1.44	1.13	3.48	1.67	.75	2.00
8	1050287	1050078	ROLLOX	5.50	9.6	7.17	5.80	1.06	.28	1.75	2.25	5.84	2.00	1.65	1.23	4.06	2.00	.88	2.25
9	1050298	1050089	ROLLOX	7.20	13.5	7.85	6.45	1.06	.31	1.88	2.50	6.50	2.06	1.81	1.38	4.65	2.21	1.03	2.50
11	1050309	1050100	TIP-LOK	9.20	20.5	9.62	8.00	1.25	.31	2.25	3.00	7.56	2.63	2.25	1.62	4.87	2.18	1.13	2.75
12	1050320	1050111	TIP-LOK	12.30	27.0	10.53	8.84	1.25	.38	2.50	3.25	8.69	2.94	2.59	1.94	5.13	2.25	1.25	3.13
14	1050342	1050133	TIP-LOK	18.50	55.0	12.60	10.75	1.41	.38	3.38	4.25	11.00	3.50	2.97	2.38	8.00	4.25	1.63	4.10

\*Ultimate Load is 4 times the Working Load Limit.



Open Swivel Bail

- Open Swivel Bail for attachment to link chain.
  - **BL-E** - with Self-Closing Gate
  - **BL-G** - with Manual-Closing Gate
- Suitable for infrequent, non-continuous rotation under load.
- Use in corrosive environment requires shank and nut inspection in accordance with ASME B30.10-1.10.4(b)(5)(c).
- Crosby®/Bullard® Hooks incorporate two types of strategically placed markings forged into the product which address two (2) **QUIC-CHECK®** features:
  - Angle Indicators and Deformation Indicators (see the Bullard® **QUIC-CHECK®** table at bottom of page 129 for detailed definition)

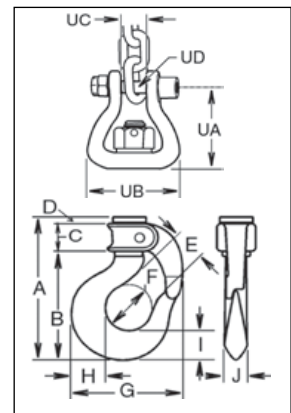

Open Swivel Bail

Hook Size	BL-E Stock No.	BL-G Stock No.	Gate Type	Working Load Limit (T)*	Weight Each (lb)	Dimensions (in)													
						A	B	C	D	E	F	G	H	I	J	UA	UB	UC	UD
3	1051607	1051706	PIN-LOK	1.40	1.8	4.50	3.31	.94	.22	1.06	1.38	3.19	.94	.84	.63	2.08	2.31	.52	.38
4	1051618	1051717	PIN-LOK	1.70	2.1	4.88	3.63	1.00	.22	1.13	1.50	3.63	1.16	1.00	.75	2.14	2.31	.52	.38
5	1051629	1051728	ROLLOX	2.30	3.2	5.63	4.12	1.23	.25	1.25	1.64	4.09	1.31	1.12	.84	2.56	2.63	.62	.44

\*Ultimate Load is 4 times the Working Load Limit.

# Crosby® / Bullard® Golden Gate® Hooks



Link Chain Nest

- With ball bearing swivel; attaches to chain by an alloy pin.
  - **BL-O** - with Self-Closing Gate
  - **BL-P** - with Manual Closing Gate
- Suitable for frequent rotation under load.
- Use in corrosive environment requires shank and nut inspection in accordance with ASME B30.10-1.10.4(b)(5)(c).
- Crosby®/Bullard® Hooks incorporate two types of strategically placed markings forged into the product which address two (2) **QUIC-CHECK®** features:
  - Angle Indicators and Deformation Indicators (see the Bullard® **QUIC-CHECK®** table at bottom of page 129 for detailed definition)

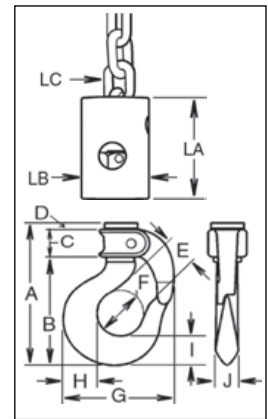

Hooks & Swivels

## Link Chain Nest

Hook Size	BL-O Stock No.	BL-P Stock No.	Gate Type	Working Load Limit (T)*	Weight Each (lb)	Dimensions (in)												
						A	B	C	D	E	F	G	H	I	J	LA	LB	LC
4:1/4-9/32	1051409	1051508	PIN-LOK	1.70	2.5	4.88	3.63	1.00	.22	1.06	1.50	3.63	1.16	1.00	.75	2.65	1.75	1/4-9/32
5:5/16-3/8	1051442	1051541	ROLLOX	2.30	4.5	5.53	4.12	1.23	.25	1.25	1.64	4.10	1.31	1.12	.84	3.00	2.25	5/16-3/8
7:3/8-7/16	1051464	1051563	ROLLOX	4.20	11.0	6.61	5.21	1.12	.25	1.50	2.00	4.94	1.63	1.44	1.13	4.38	3.00	3/8-7/16
7:1/2-9/16	1051486	1051585	ROLLOX	4.20	11.0	6.61	5.21	1.12	.25	1.50	2.00	4.94	1.63	1.44	1.13	4.38	3.00	1/2-9/16

\*Ultimate Load is 4 times the Working Load Limit.



Standard Length SHANK HOOKS

- For use on existing load blocks, with standard shank length.
- No.'s 2 through 12 style hooks are threaded approximately 80% of shank length.
  - **BL-D** - with self-closing gate.
  - **BL-B** - with manual-closing gate.
- Use in corrosive environment requires shank and nut inspection in accordance with ASME B30.10-1.10.4(b)(5)(c).
- Crosby®/Bullard® Hooks incorporate two types of strategically placed markings forged into the product which address two (2) **QUIC-CHECK®** features:
  - Angle Indicators and Deformation Indicators (see the Bullard® **QUIC-CHECK®** table at bottom of page 129 for detailed definition)

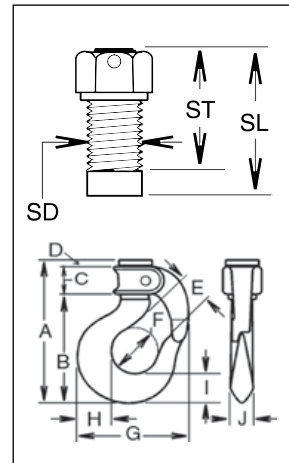

**SEE APPLICATION AND WARNING INFORMATION**  
 On Pages 146 - 147  
 Para Español: [www.thecrosbygroup.com](http://www.thecrosbygroup.com)

## Standard Length Shank Hooks

Hook Size	BL-D Stock No.	BL-B Stock No.	Gate Type	Working Load Limit (T)*	Weight Each (lb)	Dimensions (in)												
						A	B	C	D	E	F	G	H	I	J	SD	SL	ST
2	1050606	1050408	PIN-LOK	1.00	1.1	4.12	3.00	.93	.16	.97	1.25	2.88	.81	.75	.56	.50	.91	.59
3	1050617	1050419	PIN-LOK	1.40	1.3	4.50	3.31	.94	.22	1.06	1.38	3.19	.94	.84	.63	.56	1.25	.75
4	1050628	1050430	PIN-LOK	1.70	1.7	4.88	3.63	1.00	.22	1.13	1.50	3.63	1.16	1.00	.75	.63	1.31	1.19
5	1050639	1050441	ROLLOX	2.30	2.5	5.63	4.12	1.23	.25	1.25	1.64	4.09	1.31	1.12	.84	.75	1.31	1.00
6	1050650	1050452	ROLLOX	4.00	3.5	6.23	4.70	1.25	.25	1.39	1.64	4.56	1.57	1.34	.97	.88	1.69	1.16
7	1050661	1050463	ROLLOX	4.20	5.2	6.61	5.21	1.12	.25	1.50	2.00	4.94	1.63	1.44	1.13	1.00	1.81	1.38
8	1050672	1050474	ROLLOX	5.50	7.1	7.17	5.80	1.06	.28	1.75	2.25	5.84	2.00	1.65	1.23	1.13	2.06	1.50
9	1050683	1050485	ROLLOX	7.20	9.5	7.85	6.45	1.06	.31	1.88	2.50	6.50	2.06	1.81	1.38	1.25	2.44	1.81
11	1050694	1050496	TIP-LOK	9.20	15.6	9.62	8.00	1.25	.31	2.25	3.00	7.56	2.63	2.25	1.62	1.50	2.69	1.88
12	1050705	1050507	TIP-LOK	12.30	21.0	10.53	8.84	1.25	.38	2.50	3.25	8.69	2.94	2.59	1.94	1.63	2.88	2.13
13	1050716	1050518	TIP-LOK	15.00	30.0	11.23	9.54	1.25	.38	3.00	3.75	9.63	3.28	2.75	1.94	1.75	3.50	2.20
14	1050727	1050529	TIP-LOK	18.50	40.0	12.60	10.75	1.41	.38	3.38	4.25	11.00	3.50	2.97	2.38	2.00	3.75	2.38

\*Ultimate Load is 4 times the Working Load Limit. If a drawing is not available, complete a Crosby/Bullard HOOK DATA FORM. Hook No.'s 2 through 12 style hooks are threaded approximately 80% of the shank length.



# Crosby® / Bullard® Golden Gate® Hooks



Long Length  
SHANK HOOKS

- For use on existing load blocks requiring extra shank length.
- No.'s 4 through 9 style hooks are threaded approximately 80% of shank length.
  - BL-K - with Self-Closing Gate
  - BL-I - with Manual Closing Gate
- Use in corrosive environment requires shank and nut inspection in accordance with ASME B30.10-1.10.4(b)(5)(c).
- Crosby®/Bullard® Hooks incorporate two types of strategically placed markings forged into the product which address two (2) **QUIC-CHECK®** features:
  - Angle Indicators and Deformation Indicators (see the Bullard® **QUIC-CHECK®** table at bottom of this page for detailed definition)

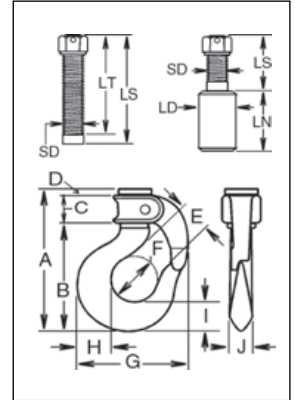

Hooks & Swivels

## Long Length Shank Hooks

Hook Size	BL-K Stock No.	BL-I Stock No.	Gate Type	Working Load Limit (T)*	Weight Each (lb)	Dimensions (in)													
						A	B	C	D	E	F	G	H	I	J	SD	LN	LS	LT
4 :1/2	1051002	1050804	PIN-LOK	1.60	1.9	4.88	3.63	1.00	.22	1.13	1.50	3.63	1.16	1.00	.75	.50	.44	3.19	3.19
4 :9/16	1051013	1050815	PIN-LOK	1.70	1.9	4.88	3.63	1.00	.22	1.13	1.50	3.63	1.16	1.00	.75	.56	.48	3.19	3.19
4 :5/8	1051024	1050826	PIN-LOK	1.70	1.9	4.88	3.63	1.00	.22	1.13	1.50	3.63	1.16	1.00	.75	.63	.55	3.31	3.19
5	1051035	1050837	ROLLOX	2.30	3.0	5.63	4.12	1.23	.25	1.25	1.64	4.09	1.31	1.12	.84	.75	.63	3.56	3.25
6	1051046	1050848	ROLLOX	4.00	3.8	6.23	4.70	1.25	.25	1.39	1.64	4.56	1.57	1.34	.97	.88	.75	4.06	3.54
7	1051057	1050859	ROLLOX	4.20	5.9	6.61	5.21	1.12	.25	1.50	2.00	4.94	1.63	1.44	1.13	1.00	.88	4.56	4.12
8	1051068	1050870	ROLLOX	5.50	7.8	7.17	5.80	1.06	.28	1.75	2.25	5.84	2.00	1.65	1.23	1.12	.94	5.06	4.50
9	1051079	1050881	ROLLOX	7.20	10.8	7.85	6.45	1.06	.31	1.88	2.50	6.50	2.06	1.81	1.38	1.25	1.06	5.56	4.94
12 ‡	1051101	1050903	TIP-LOK	12.30	28.0	10.53	8.84	1.25	.38	2.50	3.25	8.69	2.94	2.59	1.94	1.63	1.56	5.38	4.63
13 ‡	1051112	1050914	TIP-LOK	15.00	35.0	11.23	9.54	1.25	.38	3.00	3.75	9.63	3.28	2.75	1.94	1.75	1.50	7.37	5.75
14 ‡	1051123	1050925	TIP-LOK	18.50	45.0	12.60	10.75	1.41	.38	3.38	4.25	11.00	3.50	2.97	2.38	2.00	2.00	5.38	4.00
16	1051134	1050936	TIP-LOK	33.00	103.0	15.29	13.10	1.50	.63	4.00	5.00	13.62	4.63	3.63	3.00	2.75	2.75	16.00	7.00
17	1051156	1050958	TIP-LOK	66.00	370.0	24.20	20.57	2.63	.94	5.75	7.00	18.50	6.50	6.00	4.44	4.00	3.94	22.75	14.00

\*Ultimate Load is 4 times the Working Load Limit. If a drawing is not available, complete a Crosby/Bullard HOOK DATA FORM. Hook No.'s 4 through 9 are threaded approximately 80% of the shank length. ‡ Hook will have the shank extended by use of a Coupling Nut. Customer is required to complete and approve side 2 of a Crosby/Bullard HOOK DATA FORM.

## Crosby® / Bullard Golden Gate Hooks Service Parts

Hook Size	Gate Type	BL-GA Gate Assemblies		BL-RK Gate Repair Kit Stock No.
		Manual Close Stock No.	Self Close Stock No.	
2	PIN-LOK	1100298	1100309	1100100
3	PIN-LOK	1100320	1100331	1100100
4	PIN-LOK	1100342	1100353	1100100
5	ROLLOX	1100364	1100375	1100111
6	ROLLOX	1100386	1100397	1100111
7	ROLLOX	1100408	1100419	1100122
8	ROLLOX	1100430	1100441	1100122
9	ROLLOX	1100452	1100463	1100122
10	TIP-LOK	1100474	1100485	1100133
11	TIP-LOK	1100496	1100507	1100144
12	TIP-LOK	1100518	1100529	1100155
13	TIP-LOK	1100540	1100551	1100166
14	TIP-LOK	1100562	1100573	1100177
15	TIP-LOK	1100584	1100595	1100188
16	TIP-LOK	1100606	1100617	1100199
17	TIP-LOK	1100639	1100628	1100210

## Bullard® QUIC-CHECK® Deformation Indicator Table

Hook Size	Hook ID Code	AA (in)
1	1	1.50
2	D	1.50
3	F	1.50
4	G	2.00
5	H	2.00
6	6	2.50
7	I	2.50
8	8	3.00
9	J	4.00
11	K	4.00
12	L	4.50
13	13	5.00
14	N	5.00
16	O	6.50
17	T	10.00



L-320R  
ROV EYE HOOK

- Hook identification code stamped on each hook
- Quenched and Tempered.
- QUIC-CHECK® deformation and angle indicators forged on the hook.
- Fluorescent yellow finish for high "subsea" visibility .
- Tip extension allows for easy handling.
- Sizes 3.2t through 31.5t utilize new integrated latch (S-4320) that meets the world-class standard for lifting.
  - Heavy duty stamped latch interlocks with the hook tip.
  - High cycle, long life spring.
- Pad eyes are provided on either side of hook as cable guides. The cable is passed through a hole drilled in the latch that assists in allowing the "remotely operated" cable to open latch.
- Crosby supplies latches with drilled holes for sizes 5.4t through 31.5t. Other sizes can be fitted by your local Authorized Crosby Dealer. Cables are not provided by Crosby.

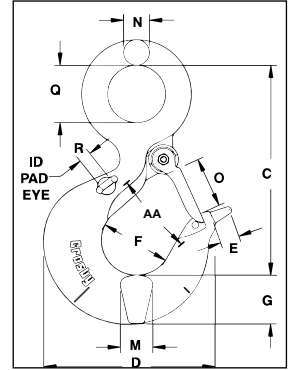

L-320R ROV Hooks

Working Load Limit (t)*	Hook ID Code	L-320R Stock No.	Weight Each (lb)	Dimensions (in)										Replacement Latch Stock No.	
				C	D	E	F	G	M	N	O	Q	R		AA**
†3.2	HA	1298427	2.0	4.69	3.97	.39	1.63	1.13	.94	.58	1.09	1.25	.25	2.00	1096468
†5.4	IA	1298497	4.0	5.77	4.81	.39	2.00	1.44	1.31	.72	1.36	1.56	.25	2.50	1096515
†8	JA	1298567	8.2	7.37	6.27	.79	2.50	1.81	1.66	.90	1.61	2.00	.38	3.00	1096562
†11.5	KA	1298637	15	9.07	7.45	1.18	3.00	2.25	1.63	1.11	2.08	2.44	.38	4.00	1096611
†16	LA	1298707	21	10.08	8.30	1.18	3.25	2.59	1.94	1.27	2.27	2.84	.38	4.00	1096657
†22	NA	1298777	38	12.53	10.30	1.77	4.25	3.00	2.38	1.56	3.02	3.50	.75	5.00	1096704
†31.5	OA	1298847	60	14.07	13.63	-	5.00	3.62	3.00	1.75	3.67	3.50	.75	6.50	1090161
37	PA	1298857	107	18.19	14.06	-	5.38	4.56	3.19	2.00	3.75	4.50	.75	7.00	1090189
45	SA	1298867	137	20.12	15.45	-	6.00	5.06	3.24	2.18	4.25	4.94	.75	8.00	1090189
60	TA	1298877	224	23.72	18.50	-	7.00	6.00	3.91	2.53	5.12	5.69	.75	10.00	1090205

\*Minimum Ultimate Load is 4 times the Working Load Limit. \*\* Deformation Indicators. † Utilizes Crosby S320N style hook. Maximum proof load is 2 times the Working Load Limit.

**ROV PRODUCTS**

Developed in conjunction with major North Sea subsea operators.

For efficient load handling and attachment for Remote Operating Vehicles in subsea and other hard-to-reach applications.

Pad eyes are placed on either side of hook as cable guides which allows the "remotely operated" cable to open latch.

Available on pages: 90, 91.

**G-2110 & G-2100**  
Release & Retrieve ROV Shackle with Non - Thread & QUIC Thread Bolt with Handle, pages 90 and 91.

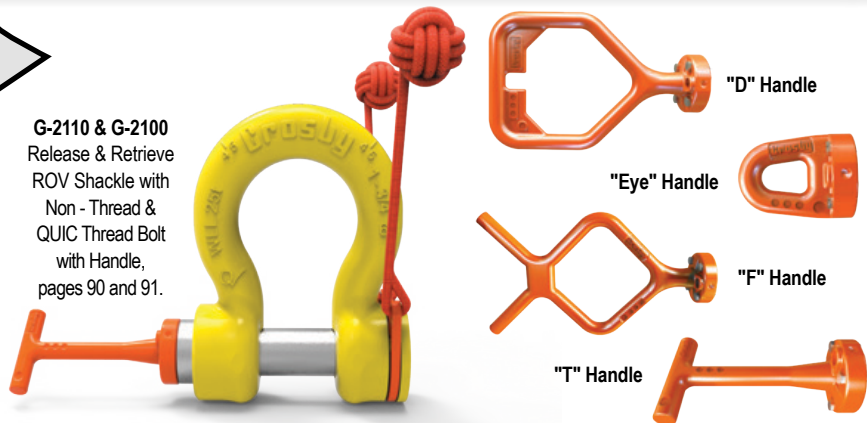

# Crosby® ROV Eye Shank Hooks



L-562A  
ROV EYE  
SHANK HOOK

- Hook identification code stamped on each hook
- Quenched and Tempered.
- QUIC-CHECK® angle indicators forged into the top eye; and deformation and angle indicators forged on the hook.
- Fluorescent yellow finish for high “subsea” visibility.
- Tip extension allows for easy handling.
- Sizes 5.4t through 31.5t utilize new integrated latch (S-4320) that meets the world-class standard for lifting.
  - Heavy duty stamped latch interlocks with the hook tip.
  - High cycle, long life spring.
- Pad eyes are provided on either side of hook as cable guides. The cable is passed through a hole drilled in the latch that assists in allowing the “remotely operated” cable to open latch.
- Crosby supplies latches with drilled holes for sizes 5.4t through 31.5t. Other sizes can be fitted by your local Authorized Crosby Dealer. Cables are not provided by Crosby.

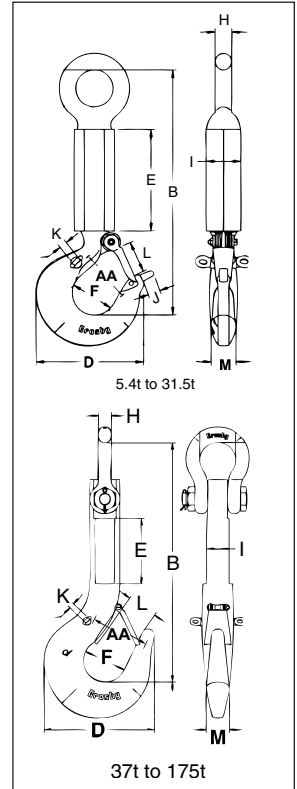

**Fatigue Rated**

**Load Rated**

CE

**QT**

QUIC-CHECK®

## L-562A ROV Eye Shank Hooks

Working Load Limit (t)	Hook ID Code	L-562A Stock No.	Weight Each (lb)	Dimensions (in)											Replacement Latch Stock No.
				I	E	B	D	J	F	M	H	L	K	AA**	
†5.4	IA	1297722	21	2.56	9.84	16.57	4.84	.39	2.00	1.13	.88	1.36	.25	2.50	1096515
†11.5	KA	1297792	33	2.56	9.84	20.39	7.54	1.18	3.00	1.63	1.25	2.08	.38	4.00	1096611
†16	LA	1297806	42	2.56	9.84	21.65	8.34	1.18	3.25	1.94	1.38	2.27	.38	4.00	1096657
†22	NA	1297862	68	3.35	9.84	23.94	10.34	1.77	4.25	2.38	1.59	3.02	.75	5.00	1096704
31.5	OA	1298042	97	3.35	9.84	26.00	13.62	-	5.00	3.00	1.89	3.62	.75	6.50	1090161
‡37	PA	1298049	97	3.15	9.25	32.58	14.06	-	5.38	3.00	1.84	3.75	.75	7.00	1090189
‡45	SA	1298057	198	3.15	9.25	34.07	15.44	-	6.00	3.25	1.84	4.25	.75	8.00	1090189
‡60	TA	1298087	289	3.54	8.46	37.06	18.50	-	7.00	3.91	2.08	5.12	.75	10.00	1090205
‡100	WA	1298103	668	5.51	11.81	46.67	23.00	-	6.81	5.50	2.71	4.88	.75	12.00	1090241
‡150	XA	1298117	871	5.91	9.06	48.53	24.38	-	6.75	6.00	3.62	5.38	.75	13.00	1090241
***175	YA	1298130	1135	6.69	10.04	52.24	26.69	-	7.50	7.00	4.00	-	.75	13.00	143062

\*Minimum Ultimate Load is 4 times the Working Load Limit. \*\* Deformation Indicators. † Utilizes Crosby S319N style hook. Maximum proof load is 2 times the Working Load Limit. ‡ Utilizes Crosby G-2140 shackle as eye.

### Did You Know...

there are three indicators built into almost every Crosby hook?

- **Deformation Indicator:** for abuse and overload.
- **Angle Indicators:** insure the maximum include angle which is allowed between two (2) sling legs.
- **Two Letters Code:** One letter represents the size and weight of the hook. The other letter tells you what material the hook is made of.







**BH-313  
WELD-ON  
HOOK**

- Wide range of sizes available: 1-10 metric ton capacity.
- Forged Alloy Steel.
- Designed for attachment to mobile lifting equipment to provide a pick point for easy sling attachment.
- Large weld pad.
- Heavy duty latch interlocks with the hook tip. Replacement latches available.
- Detailed installation and application instructions included with each hook.

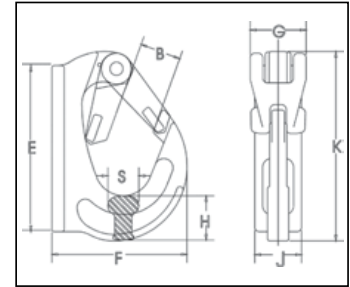

**BH-313 Weld-On Hooks**

Working Load Limit (t)*	BH-313 Stock No.	Weight Each (lb)	Dimensions (in)								Replacement Latch Stock No.
			B	E	F	G	H	J	K	S	
1	1029105	1.15	.91	3.82	2.80	1.42	1.06	1.02	4.21	.71	1092104
2	1029114	1.85	.91	3.23	3.58	1.42	.98	1.34	4.53	.83	1092104
3	1029123	2.60	1.14	4.61	4.13	1.42	1.22	1.42	5.16	.94	1092104
4	1029132	4.19	1.34	5.16	4.49	1.81	1.42	1.69	5.79	1.14	1092105
5	1029141	5.62	1.34	6.34	5.24	1.85	1.77	1.73	6.81	1.14	1092105
8	1029150	7.28	1.38	6.54	5.31	1.85	2.05	2.05	7.01	1.54	1092105
10	1029169	11.02	1.93	8.07	6.61	1.85	2.24	2.13	8.74	1.54	1092106

\* Ultimate Load is 5 times the Working Load Limit.



**S-3319  
UTILITY SWIVEL  
HOOK**

- Capacities of 1.63, 2.50 and 4.50 metric tons
- Synthetic Rope sizes: 9/16" - 1-1/16"
- Hook is forged Alloy Steel - Quenched and Tempered.
- Can be proof tested to 2 times the Working Load Limit.
- Designed for utility applications using synthetic rope.
- Design of hook provides needed overhaul weight.
- Utilizes spool & shield designed to:
  - Protect rope
  - Keep rope positioned correctly on spool.
  - Provide wider rope bearing surface resulting in an increased area for load distribution and reduces rope abrasion.
- Low profile hook tip designed to utilize Crosby integrated latch (S-4320), that meets the world-class standard for lifting.

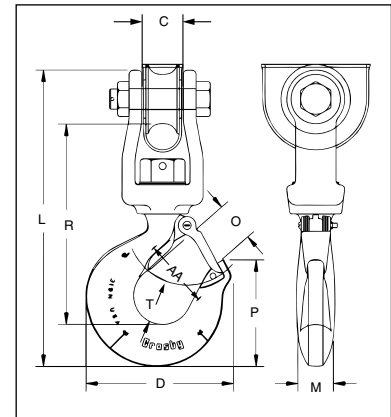

*Suitable for infrequent, non-continuous rotation under load. Use in corrosive environment requires shank and nut inspection in accordance with ASME B30.10-1.10.4(b)(5)(c)2009.*



**S-3319 Utility Swivel Hook**

Working Load Limit (t)*	S-3319 Stock No.	Weight Each (lb)	Hook ID Code	Synthetic Rope Size (in)	Dimensions (in)									Replacement Latch Kit Stock No.
					C	D	L	M	O	P	R	T	AA**	
1.63	1002054	4.2	H	9/16 - 5/8	1.09	3.99	8.75	.94	1.16	2.78	5.94	1.16	2.00	1096468
2.50	1002063	8.0	I	3/4 - 13/16	1.31	4.84	10.56	1.13	1.41	3.47	7.06	1.53	2.50	1096515
4.50	1002072	15.0	J	7/8 - 1-1/16	1.78	6.29	12.75	1.44	1.78	4.59	8.69	1.94	3.00	1096562

\*Ultimate Load is 5 times the Working Load Limit. \*\* Deformation Indicators.

# Crosby® Forged Hooks



**A-350L**  
SLIDING CHOKER HOOK

- New style incorporates throat opening equal to or larger than old style hooks.
- Each product has a Product Identification Code (PIC) for material traceability, along with a Working Load Limit, and the name Crosby or "CG" forged into it.
- All hooks incorporate Crosby's patented QUIC-CHECK® marks to help in determining if throat opening dimension has changed.
- Each hook is equipped with a Crosby S-4320 heavy duty stamped latch with the high cycle, long life spring.
- Forged Alloy Steel -- Quenched and Tempered.

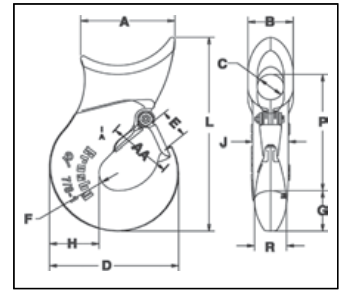

## A-350L Sliding Choker Hook

Single Part Rope Size (in)	Eight Part Rope Size (in)	A-350L Stock No.	Working Load Limit (lb)	Weight Each (lb.)	Dimensions (in)													Hook Frame Code	Replacement Latch Kit Stock No.
					A	B	C	D	E	F	G	H	L	P	R	AA**			
3/8	-	1011802	2500	1.0	2.06	1.13	.63	2.41	.63	.38	.84	.91	4.28	2.59	.63	1.50	D	1096325	
1/2	1/8	1011811	3800	1.4	2.25	1.31	.75	2.97	.78	.50	.97	1.06	4.97	3.09	.75	1.50	F	1096374	
† 5/8	-	1011820	5800	3.0	3.06	1.63	.75	3.56	.94	.56	1.13	1.31	6.38	3.88	1.00	2.00	G	1096421	
† 5/8	3/16	1011839	5800	2.7	3.06	1.63	1.00	3.56	.94	.56	1.13	1.31	6.38	4.00	1.13	2.00	G	1096421	
† 3/4	-	1011848	8200	4.4	3.38	2.13	1.00	4.25	1.16	.63	1.44	1.63	7.66	4.58	1.13	2.50	H	1096468	
† 3/4	1/4	1011857	8200	3.8	3.38	2.13	1.44	4.25	1.16	.63	1.44	1.63	7.66	4.78	1.13	2.50	H	1096468	
†† 7/8-1	-	1028177	15000	9.70	4.41	2.12	1.25	6.06	1.41	.88	2.00	2.33	9.55	5.72	1.50	3.00	I	1096515	

\*\* Deformation Indicators. † Determine EYE diameter "C", before ordering. †† 7/8-1" is Cast Steel.



**G-3315**  
SNAP HOOK

- Forged Carbon Steel -- Quenched and Tempered.
- Pressed steel latches and stainless steel springs, bolts and nuts.
- For replacement latch kit, order Stock No. 9900299.
- Hook Body -- Galvanized.

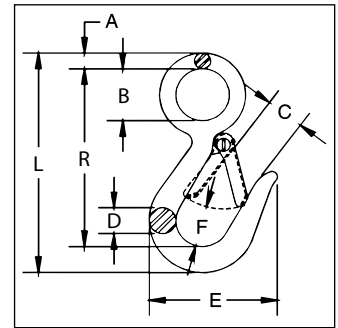

## G-3315 Snap Hook

Hook Size (in)	G-3315 Stock No.	Working Load Limit (lb)*	Weight Each (lb)	Dimensions (in)							
				A	B	C	D	E	F	L	R
7/16	1023056	750	.23	.25	.75	.75	.44	2.25	.75	3.94	3.25
9/16	1023074	1000	.48	.34	1.12	.81	.56	2.69	.88	4.75	3.84

\*Ultimate Load is 4 times the Working Load Limit.



**1210 Round**  
REVERSE  
EYE HOOK

- Forged Carbon Steel -- Galvanized.

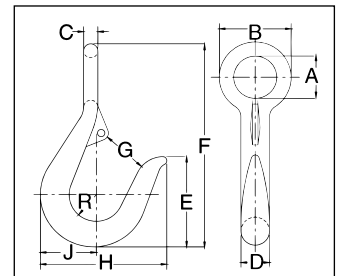

## 1210 Round Reverse Eye Hook

Size (in)	1210 Stock No.	Working Load Limit (lb)*	Weight Each (lb)	Latch Stock No.	Dimensions (in)									
					A	B	C	D	E	F	G	H	J	R
1/2	919019	300	.4	1090027	.81	1.38	.28	.50	1.62	4.00	.75	2.25	.97	.47
5/8	919037	400	.6	1090027	.94	1.56	.31	.62	2.00	4.50	.94	2.75	1.22	.59
3/4	919055	700	1.1	1090045	1.12	1.88	.38	.75	2.25	5.25	1.06	3.00	1.44	.69
7/8	919073	1200	1.6	1096468	1.19	2.06	.44	.88	3.00	6.50	1.25	3.38	1.63	.75
1 - 1-1/8	919091	1800	2.0	1090081	1.50	2.75	.62	1.12	3.50	8.00	1.50	4.38	2.00	.94
1-1/4 - 1-3/8	919135	2700	5.5	1090081	1.88	3.50	.81	1.38	4.00	9.12	1.62	5.00	2.38	1.06

\*Ultimate Load is 4 times the Working Load Limit.



**S-377**  
BARREL HOOKS

- Forged Carbon Steel - Quenched and Tempered.
- Meets the performance requirements of Federal Specification RR-C-271G, Type V, Class 6, except for those provisions required of the contractor.



**S-377 Barrel Hooks**

Working Load Limit Per Pair (Tons)*	S-377 Stock No. Per Pair	Weight Each Per Pair (lb)	Dimensions (in)			
			I.D. of Eye	O.D. of Eye	Overall Length	Width of Lip
1	1028248	3.56	1.56	2.81	5.00	2.88

\*Ultimate Load is 4 times the Working Load Limit.



**S-3316**  
REPLACEMENT HOOK

- Easily attaches to any chain and electric hoist with welded link load chain, roller chain or wire rope with suitable end fitting
- Swivel jaw is forged.
- Suitable for infrequent, non-continuous rotation under load.
- Use in corrosive environment requires shank and nut inspection in accordance with ASME B30.10-1.10.4(b)(5)(c).

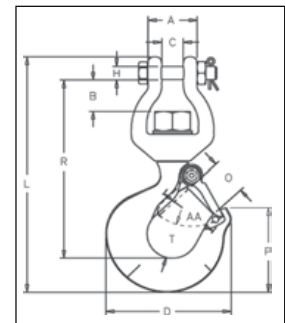

**S-3316 Replacement Hook**

Working Load Limit (Tons)*	Frame Code	S-3316 Stock No.	Weight Each (lb)	Dimensions (in)										Replacement Latch Kit Stock No.
				A	B	C	D	H	L	O	P	R	T	
1/2	F	1023029	1.25	1.31	.76	.56	3.19	.38	6.12	.97	2.25	4.59	.81	1096374
1	H	1023047	2.61	1.56	1.00	.69	4.09	.44	7.69	1.12	2.84	5.81	1.19	1096468

\*Ultimate Load is 5 times the Working Load Limit.



**A-378**  
SORTING HOOK

- Forged Alloy Steel - Quenched and Tempered.
- Deep straight throat permits efficient handling of flat plates or large cylindrical shapes.



**A-378**  
SORTING HOOK

**A-378 Sorting Hook**

Working Load Limit at tip of Hook (Tons)*	Working Load Limit at bottom of Hook (Tons)*	A-378 Stock No	Style	Weight Each (lb)	Dimensions (in)			
					I.D. of Eye	Overall Length	Opening at top of Hook	Radius at bottom of Hook
2	7-1/2	1028024	No Handle	6.42	1.38	9.69	2.81	.625
2	7-1/2	1028033	With Handle	6.42	1.38	9.69	2.81	.625

\*Ultimate Load is 4 times the Working Load Limit.



# Crosby® Forged Swivels

## Forged Swivels

- Hot dip Galvanized
- Quenched & Tempered
- Crosby products meet or exceed all requirements of ASME B30.26 including identification, ductility, design factor, proof load and temperature requirements. Importantly, Crosby products meet other critical performance requirements, including fatigue life, impact properties and material traceability, not addressed by ASME B30.26.

 402 and 403 swivels are positioning devices and are not intended to rotate under load. For load swivels see pages 136-140. Use in corrosive environment requires shank and nut inspection in accordance with ASME B30.10-1.10.4(b)(5)(c).



1/4" - 1 1/4" size

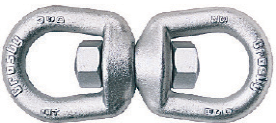

1 1/2" size

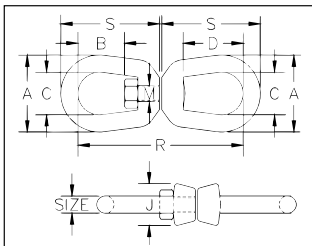

## G-402 Regular Swivels

Meets the performance requirements of Federal Specification RR-271G, Type VII, Class 2, except for those provisions required of the contractor. For more information, see page 452.

Size (in)	G-402 Stock No.	Working Load Limit (lb)*	Weight Each (lb)	Dimensions (in)							
				A	B	C	D	J	M	R	S
1/4	1016019	850	.21	1.25	.69	.75	1.06	.69	.31	2.94	1.69
5/16	1016037	1250	.39	1.63	.81	1.00	1.25	.81	.38	3.56	2.06
3/8	1016055	2250	.71	2.00	.94	1.25	1.50	1.00	.50	4.31	2.50
1/2	1016073	3600	1.32	2.50	1.31	1.50	2.00	1.31	.63	5.44	3.19
5/8	1016091	5200	2.49	3.00	1.56	1.75	2.38	1.50	.75	6.56	3.88
3/4	1016117	7200	4.02	3.50	1.75	2.00	2.63	1.88	.88	7.19	4.31
7/8	1016135	10000	6.25	4.00	2.06	2.25	3.06	2.13	1.00	8.38	5.00
1	1016153	12500	8.95	4.50	2.31	2.50	3.50	2.38	1.13	9.63	5.75
1-1/4	1016199	18000	16.37	5.63	2.69	3.13	3.69	3.00	1.50	11.44	6.75
1-1/2+	1016215	45200	45.79	7.09	3.88	4.09	3.88	3.75	2.25	16.69	9.91

\*Ultimate Load is 5 times the Working Load Limit. + Manufactured with two 1 1/2" bails connected by a stud with a nut on each side.

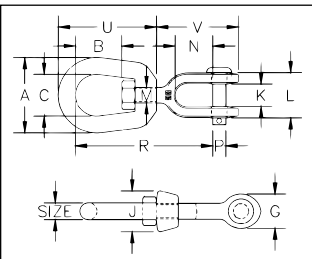

## G-403 Jaw End Swivels

Meets the performance requirements of Federal Specification RR-271G, Type VII, Class 3, except for those provisions required of the contractor. For more information, see page 452.

Size (in)	G-403 Stock No.	Working Load Limit (lb)*	Weight Each (lb)	Dimensions (in)												
				A	B	C	G	J	K	L	M	N	P	R	U	V
1/4	1016395	850	.21	1.25	.69	.75	.69	.69	.47	1.03	.31	.88	.25	2.63	1.69	1.69
5/16	1016411	1250	.34	1.63	.81	1.00	.81	.81	.50	1.13	.38	.88	.31	2.94	2.06	1.81
3/8	1016439	2250	.66	2.00	.94	1.25	1.00	1.00	.63	1.41	.50	1.06	.38	3.63	2.50	2.25
1/2	1016457	3600	1.34	2.50	1.31	1.50	1.31	1.31	.75	1.75	.63	1.31	.50	4.50	3.19	2.88
5/8	1016475	5200	2.48	3.00	1.56	1.75	1.63	1.50	.94	2.06	.75	1.50	.63	5.31	3.88	3.44
3/4	1016493	7200	3.88	3.50	1.75	2.00	1.88	1.88	1.13	2.53	.88	1.75	.75	6.06	4.31	4.00
7/8	1016518	10000	5.87	4.00	2.06	2.25	2.13	2.13	1.34	2.79	1.00	2.06	.88	7.00	5.00	4.53
1	1016536	12500	9.84	4.50	2.31	2.50	2.63	2.38	1.75	3.72	1.13	2.81	1.13	8.56	5.75	5.94
1-1/4	1016572	18000	15.75	5.69	2.69	3.13	3.13	3.00	2.06	4.31	1.63	2.81	1.38	9.75	7.06	6.38
1-1/2	1016590	45200	54.75	7.00	3.88	4.00	5.63	4.00	2.88	6.00	2.25	4.44	2.25	14.25	10.00	10.84

\*Ultimate Load is 5 times the Working Load Limit.

Hooks & Swivels



**Equipped with Tapered Roller Thrust Bearing**

- Suitable for frequent rotation under load.
- All swivels individually proof tested with labeled documentation.
- All hooks furnished with latches assembled.
- All jaws complete with bolts, nuts and cotter pins.
- Pressure lube fitting provided.
- **NOT TO BE USED ON DEMOLITION (WRECKING) BALLS.**
- Other types and capacities up to 1250t, available to meet your requirements.
- **IMPORTANT - Crosby Swivels should only be used with the recommended wire rope. Contact the wire rope manufacturer for the proper wire rope to be used with Crosby Swivels.**



**S-1 Jaw & Hook**

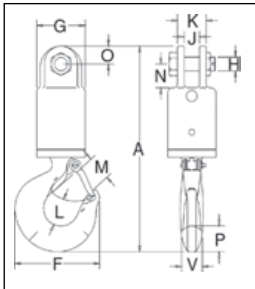

Swivel No.	S-1 Stock No.	Working Load Limit (t)*	Wire Rope Size (in)	Weight Each (lb)	Dimensions (in)													
					A	F	G	H	J	K	L	M	N	O	P	V		
3-S-1	297011	3	1/2	9.81	11.44	4.84	2.75	.75	.88	1.00	2.25	1.94	1.69	1.62	1.12	1.12	1.44	1.12
5-S-1	297217	5	5/8	15.51	13.34	6.28	3.00	.88	1.00	2.25	1.94	1.69	1.62	1.12	1.12	1.81	1.44	1.44
8-S-1	297413	8-1/2	3/4	29.42	16.45	7.54	4.00	1.00	1.56	2.81	2.46	2.22	2.12	1.38	2.25	1.62	1.62	1.62
10-S-1	297618	10	7/8	46.75	19.75	8.34	4.50	1.50	1.75	3.38	2.59	2.41	3.50	1.75	2.59	1.94	1.94	1.94
15-S-1	297814	15	1	73.75	22.24	10.34	5.00	1.50	1.75	3.38	2.81	3.19	3.50	1.75	3.00	2.38	2.38	2.38
25-S-1	298118	25	-	140.00	26.78	13.62	6.00	2.00	2.00	4.62	3.44	3.62	3.69	2.38	3.66	3.00	3.00	3.00
35-S-1	298216	35	-	220.00	29.94	14.06	6.50	2.00	2.00	4.62	3.88	3.75	3.69	2.38	4.56	3.19	3.19	3.19
45-S-1	298314	45	-	251.00	35.06	15.44	7.00	2.25	2.50	5.00	4.75	4.25	4.00	3.00	5.06	3.25	3.25	3.25

\*Individually Proof Tested to 2 times the Working Load Limit. Ultimate Load is 5 times the Working Load Limit.

**S-2 Jaw & Jaw**

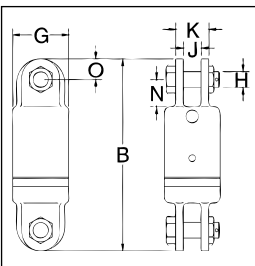

Swivel No.	S-2 Stock No.	Working Load Limit (t)*	Wire Rope Size (in)	Weight Each (lb)	Dimensions (in)								
					B	G	H	J	K	N	O		
3-S-2	297020	3	1/2	9.63	9.28	2.75	.75	.88	1.62	1.31	1.00		
5-S-2	297226	5	5/8	13.69	10.31	3.00	.88	1.00	2.25	1.62	1.12		
8-S-2	297422	8-1/2	3/4	26.16	12.62	4.00	1.00	1.56	2.81	2.12	1.38		
10-S-2	297627	10	7/8	45.75	16.75	4.50	1.50	1.75	3.38	3.50	1.75		
15-S-2	297823	15	1	62.75	17.12	5.00	1.50	1.75	3.38	3.50	1.75		
25-S-2	298127	25	-	140.00	20.75	6.00	2.00	2.00	4.62	3.69	2.38		
35-S-2	298225	35	-	155.00	20.75	6.50	2.00	2.00	4.62	3.69	2.38		
45-S-2	298323	45	-	235.00	25.25	7.00	2.25	2.50	5.00	4.00	3.00		

\*Individually Proof Tested to 2 times the Working Load Limit. Ultimate Load is 5 times the Working Load Limit.

**S-3 Jaw & Eye**

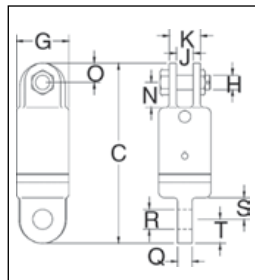

Swivel No.	S-3 Stock No.	Working Load Limit (t)*	Wire Rope Size (in)	Weight Each (lb)	Dimensions (in)											
					C	G	H	J	K	N	O	Q	R	S	T	
3-S-3	297039	3	1/2	9.12	9.34	2.75	.75	.88	1.62	1.31	1.00	.75	1.03	1.12	1.25	1.25
5-S-3	297235	5	5/8	13.50	10.06	3.00	.88	1.00	2.25	1.62	1.12	1.00	1.28	1.25	1.25	1.25
8-S-3	297431	8-1/2	3/4	24.90	12.25	4.00	1.00	1.56	2.81	2.12	1.38	1.25	1.41	1.62	1.50	1.50
10-S-3	297636	10	7/8	43.50	16.12	4.50	1.50	1.75	3.38	3.50	1.75	1.69	1.69	2.75	1.88	1.88
15-S-3	297832	15	1	61.00	16.75	5.00	1.50	1.75	3.38	3.50	1.75	1.94	2.03	2.75	2.12	2.12
25-S-3	298136	25	-	135.00	21.50	6.00	2.00	2.00	4.62	3.69	2.38	2.25	2.31	3.88	2.38	2.38
35-S-3	298234	35	-	150.00	21.50	6.50	2.00	2.00	4.62	3.69	2.38	2.25	2.31	3.88	2.38	2.38
45-S-3	298332	45	-	225.00	25.88	7.00	2.25	2.50	5.00	4.00	3.00	2.50	2.53	4.00	3.00	3.00

\*Individually Proof Tested to 2 times the Working Load Limit. Ultimate Load is 5 times the Working Load Limit.

## S-4 Eye & Jaw

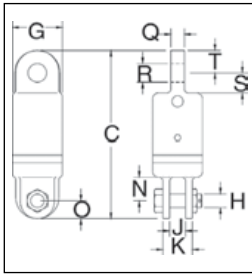

Swivel No.	S-4 Stock No.	Working Load Limit (t)*	Wire Rope Size (in)	Weight Each (lb)	Dimensions (in)										
					C	G	H	J	K	N	O	Q	R	S	T
3-S-4	297048	3	1/2	9.00	9.34	2.75	.75	.88	1.62	1.31	1.00	.75	1.03	1.12	1.25
5-S-4	297244	5	5/8	12.33	10.06	3.00	.88	1.00	2.25	1.62	1.12	1.00	1.28	1.25	1.25
8-S-4	297440	8-1/2	3/4	29.00	12.25	4.00	1.00	1.56	2.81	2.12	1.38	1.25	1.41	1.62	1.50
10-S-4	297645	10	7/8	44.00	16.12	4.50	1.50	1.75	3.38	3.50	1.75	1.69	1.69	2.75	1.88
15-S-4	297841	15	1	61.00	16.75	5.00	1.50	1.75	3.38	3.50	1.75	1.94	2.03	2.75	2.12
25-S-4	298145	25	-	135.00	21.50	6.00	2.00	2.00	4.62	3.69	2.38	2.25	2.31	3.88	2.38
35-S-4	298243	35	-	150.00	21.50	6.50	2.00	2.00	4.62	3.69	2.38	2.25	2.31	3.88	2.38
45-S-4	298341	45	-	225.00	25.88	7.00	2.25	2.50	5.00	4.00	3.00	2.50	2.53	4.00	3.00

\*Individually Proof Tested to 2 times the Working Load Limit. Ultimate Load is 5 times the Working Load Limit.

## S-5 Eye & Eye

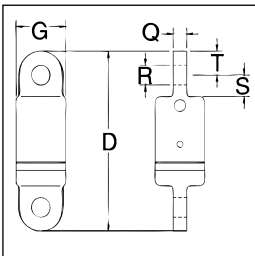

Swivel No.	S-5 Stock No.	Working Load Limit (t)*	Wire Rope Size (in)	Weight Each (lb)	Dimensions (in)					
					D	G	Q	R	S	T
3-S-5	297057	3	1/2	8.50	9.41	2.75	.75	1.03	1.12	1.25
5-S-5	297253	5	5/8	11.30	9.81	3.00	1.00	1.28	1.25	1.25
8-S-5	297459	8-1/2	3/4	29.25	11.88	4.00	1.25	1.41	1.62	1.50
10-S-5	297654	10	7/8	42.00	15.50	4.50	1.69	1.69	2.75	1.88
15-S-5	297850	15	1	49.00	16.38	5.00	1.94	2.03	2.75	2.12
25-S-5	298154	25	-	130.00	22.25	6.00	2.25	2.31	3.88	2.38
35-S-5	298252	35	-	145.00	22.25	6.50	2.25	2.31	3.88	2.38
45-S-5	298350	45	-	215.00	26.50	7.00	2.50	2.53	4.00	3.00

\*Individually Proof Tested to 2 times the Working Load Limit. Ultimate Load is 5 times the Working Load Limit.

## S-6 Eye & Hook

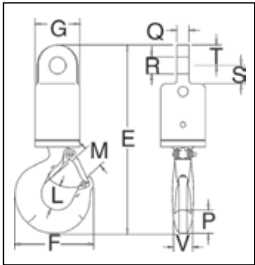

Swivel No.	S-6 Stock No.	Working Load Limit (t)*	Wire Rope Size (in)	Weight Each (lb)	Dimensions (in)										
					E	F	G	L	M	P	Q	R	S	T	V
3-S-6	297066	3	1/2	9.32	11.50	4.84	2.75	1.53	1.41	1.44	.75	1.03	1.12	1.25	1.12
5-S-6	297262	5	5/8	14.24	13.09	6.28	3.00	1.94	1.69	1.81	1.00	1.28	1.25	1.25	1.44
8-S-6	297468	8-1/2	3/4	32.00	16.07	7.54	4.00	2.46	2.22	2.25	1.25	1.41	1.62	1.50	1.62
10-S-6	297663	10	7/8	45.50	19.12	8.34	4.50	2.59	2.41	2.59	1.69	1.69	2.75	1.88	1.94
15-S-6	297869	15	1	63.00	21.24	10.34	5.00	2.81	3.19	3.00	1.94	2.03	2.75	2.12	2.38
25-S-6	298163	25	-	135.00	27.53	13.62	6.00	3.44	3.62	3.66	2.25	2.31	3.88	2.38	3.00
35-S-6	298261	35	-	215.00	30.69	14.06	6.50	3.88	3.75	4.56	2.25	2.31	3.88	2.38	3.19
45-S-6	298369	45	-	270.00	35.69	15.44	7.00	4.75	4.25	5.06	2.50	2.53	4.00	3.00	3.25

\*Individually Proof Tested to 2 times the Working Load Limit. Ultimate Load is 5 times the Working Load Limit.



**NOTE:** For swivels larger than 45 metric tons, or designed to meet the requirements of demanding applications such as subsea applications, please contact the Crosby Engineered Solutions. For additional information concerning custom design products, contact:  
 In U.S.A. - Crosby's Engineered Solutions at 1-800-777-1555, Fax (918) 834-5035.  
 In Europe - N.V. Crosby Europe at +32 15 75 71 25.



# Crosby® Angular Contact Bearing Swivels



## Angular Contact Bearing Swivels

- Wide range of product available.
  - Capacity: 0.45 through 35 tons
  - Wire Rope Sizes: 1/8" through 1-1/2"
- Individually Proof Tested to 2 times the Working Load Limit with certification
- Design Factor of 5 to 1.
- Entire swivel is Zinc plated to resist corrosion.
- Angular contact bearings maximize efficiency, reliability and service life of swivel and extend the life of the wire rope.
- Designed for high rotation speed: Lower torque required to initiate rotation.
- Hook models utilize genuine Crosby hooks which are forged alloy steel, Quenched and Tempered and contain patented QUIC-CHECK® markings.
- Each swivel 8.5 tons and larger, is furnished with a pressure lubrication fitting
- For swivels larger than those listed, contact Engineered Solutions at 1-800-777-1555.

Wire Rope Size (in)	AS-20 Stock No.
1/2	1038200
5/8	1038209
3/4	1038218
7/8 - 1	1038227
1-1/8 - 1-1/4	1038236
1-1/2	1038245

## AS-20 Thimble Insert

- When terminating with wire rope clips, we recommend the use of the Thimble Insert. The result will be extended wire rope life.
- Allows standard swivel to be used in application requiring a thimble fitting.
- For use with our Bullet Style (AS-7) and Jaw Style (AS-1, AS-2, AS-3 & AS-4) swivels.
- Machined from carbon steel. Zinc plated.

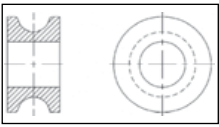

## AS-1 Jaw & Hook

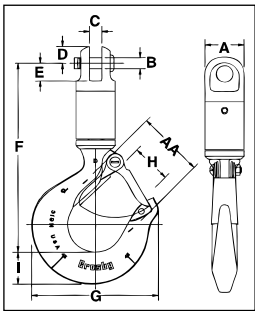

AS-1 JAW & HOOK				Dimensions (in)									Deformation Indicator AA	Replacement Latch Kit Stock No.
Working Load Limit (Tons)*	Wire Rope Size (in)	AS-1 Stock No.	Weight Each (lb)	A	B	C	D	E	F	G	H	I		
.45	1/8	1016001	.7	.88	.25	.25	.38	.41	4.32	2.86	.93	.73	1.50	1096325
.75	1/4	1016010	1.5	1.31	.38	.31	.44	.56	5.44	3.16	.97	.84	1.50	1096374
1.5	3/8	1016025	2.3	1.63	.50	.53	.69	.78	6.35	4.00	1.16	1.14	1.50	1096374
3.0	1/2	1016026	6.5	2.00	.75	.75	.94	1.19	8.69	4.84	1.41	1.44	2.50	1096374
5.0	5/8	1016040	12.9	2.50	.88	1.00	1.13	1.53	10.71	6.28	1.69	1.82	3.00	1096562
8.5	3/4	1016045	26.4	3.00	1.19	1.56	1.34	2.09	13.65	8.34	2.41	2.60	4.00	1096657
10	7/8	1016056	53.0	4.00	1.50	1.75	1.75	3.50	17.95	10.34	3.19	3.00	5.00	1096704
15	1	1016064	53.0	4.00	1.50	1.75	1.75	3.50	17.95	10.34	3.19	3.00	5.00	1096704
25	1-1/4	1016075	97.0	5.00	2.00	2.00	2.38	3.69	20.88	13.62	3.25	3.62	6.50	1090161
35	1-1/2	1016082	140.0	5.00	2.00	2.00	2.38	3.69	24.00	14.06	3.00	4.56	7.00	1090189

\*Ultimate Load is 5 times the Working Load Limit. Individually Proof Tested to 2 times the Working Load Limit.

## AS-2 Jaw & Jaw

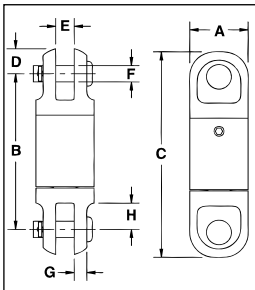

AS-2 JAW & JAW				Dimensions (in)							
Working Load Limit (Tons)*	Wire Rope Size (in)	AS-2 Stock No.	Weight Each (lb)	A	B	C	D	E	F	G	H
.45	1/8	1016103	.4	.88	2.38	3.13	.38	.25	.25	.19	.41
.75	1/4	1016114	.9	1.31	3.56	4.44	.44	.31	.38	.22	.56
1.5	3/8	1016122	2.0	1.63	4.06	5.44	.69	.50	.50	.28	.78
3.0	1/2	1016131	4.9	2.00	6.25	8.13	.94	.75	.75	.38	1.19
5.0	5/8	1016139	9.6	2.50	7.75	10.63	1.13	1.00	.88	.53	1.53
8.5	3/4	1016148	15.8	3.00	9.63	12.31	1.34	1.56	1.19	.56	2.09
10	7/8	1016157	40.0	4.00	14.00	17.50	1.75	1.75	1.50	.81	3.50
15	1	1016166	40.0	4.00	14.00	17.50	1.75	1.75	1.50	.81	3.50
25	1-1/4	1016175	78.0	5.00	15.94	20.69	2.38	2.00	2.00	1.13	3.69
35	1-1/2	1016184	78.0	5.00	15.94	20.69	2.38	2.00	2.00	1.13	3.69

\*Ultimate Load is 5 times the Working Load Limit. Individually Proof Tested to 2 times the Working Load Limit.



**NOTE:** For swivels larger than 35 tons, or designed to meet the requirements of demanding applications such as subsea applications, please contact the Crosby Engineered Solutions. For additional information concerning custom design products, contact:  
 In U.S.A. - Crosby's Engineered Solutions at 1-800-777-1555, Fax (918) 834-5035.  
 In Europe - N.V. Crosby Europe at +32 15 75 71 25.

# Crosby® Angular Contact Bearing Swivels

## AS-3 Jaw & Eye

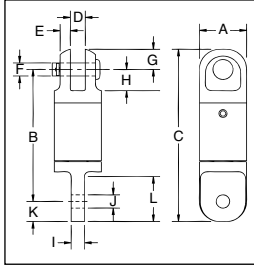

AS-3 JAW & EYE				Dimensions (in)											
Working Load Limit (Tons)*	Wire Rope Size (in)	AS-3 Stock No.	Weight Each (lb)	A	B	C	D	E	F	G	H	I	J	K	L
.45	1/8	1016205	.3	.88	2.50	3.25	.25	.19	.25	.38	.41	.25	.25	.38	.84
.75	1/4	1016216	.9	1.31	3.69	4.56	.31	.22	.38	.44	.56	.31	.38	.44	.88
1.5	3/8	1016224	1.9	1.63	4.19	5.44	.50	.28	.50	.69	.78	.50	.66	.63	1.38
3.0	1/2	1016232	4.6	2.00	6.19	8.13	.75	.38	.75	.94	1.19	.75	.91	1.00	2.00
5.0	5/8	1016243	9.1	2.50	7.88	10.19	1.00	.53	.88	1.13	1.50	1.00	1.25	1.19	2.63
8.5	3/4	1016250	15.6	3.00	9.50	12.25	1.56	.56	1.25	1.34	2.09	1.25	1.41	1.50	3.13
10	7/8	1016259	39.0	4.00	13.75	17.31	1.75	.81	1.50	1.75	3.50	1.72	1.63	1.81	4.69
15	1	1016268	40.0	4.00	13.44	17.31	1.75	.81	1.50	1.75	3.50	2.00	2.00	2.13	4.69
25	1-1/4	1016277	78.0	5.00	16.00	20.75	2.00	1.13	2.00	2.38	3.69	2.25	2.31	2.38	5.25
35	1-1/2	1016286	78.0	5.00	16.00	20.75	2.00	1.13	2.00	2.38	3.69	2.25	2.31	2.38	5.2

\*Ultimate Load is 5 times the Working Load Limit. Individually Proof Tested to 2 times the Working Load Limit.

## AS-4 Eye & Jaw

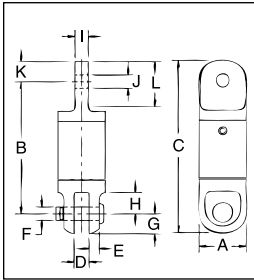

AS-4 EYE & JAW				Dimensions (in)											
Working Load Limit (Tons)*	Wire Rope Size (in)	AS-4 Stock No.	Weight Each (lb)	A	B	C	D	E	F	G	H	I	J	K	L
.45	1/8	1016306	.3	.88	2.50	3.25	.25	.19	.25	.38	.41	.25	.25	.38	.81
.75	1/4	1016314	.9	1.31	3.63	4.56	.31	.22	.38	.44	.56	.31	.38	.44	.88
1.5	3/8	1016325	1.9	1.63	4.19	5.50	.50	.28	.50	.69	.78	.50	.66	.63	1.34
3.0	1/2	1016332	4.6	2.00	6.19	8.13	.75	.38	.75	.94	1.19	.75	.91	1.00	2.00
5.0	5/8	1016343	9.1	2.50	7.88	10.19	1.00	.53	.88	1.13	1.44	1.00	1.25	1.19	2.63
8.5	3/4	1016352	15.7	3.00	9.44	12.25	1.56	.56	1.19	1.34	2.09	1.25	1.41	1.50	3.13
10	7/8	1016361	39.0	4.00	14.13	17.75	1.75	.81	1.50	1.75	3.50	1.72	1.66	1.81	4.69
15	1	1016370	40.0	4.00	13.81	17.75	1.75	.81	1.50	1.75	3.50	2.00	2.03	2.13	4.69
25	1-1/4	1016375	75.0	5.00	15.94	20.75	2.00	1.13	2.00	2.38	3.69	2.25	2.31	2.38	5.25
35	1-1/2	1016379	75.0	5.00	15.94	20.75	2.00	1.13	2.00	2.38	3.69	2.25	2.31	2.38	5.25

\*Ultimate Load is 5 times the Working Load Limit. Individually Proof Tested to 2 times the Working Load Limit.

## AS-5 Eye & Eye

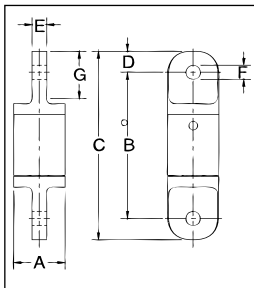

AS-5 EYE & EYE				Dimensions (in)						
Working Load Limit (Tons)*	Wire Rope Size (in)	AS-5 Stock No.	Weight Each (lb)	A	B	C	D	E	F	G
.45	1/8	1016409	.3	.88	2.63	3.38	.38	.25	.25	.81
.75	1/4	1016418	.9	1.31	3.75	4.63	.44	.31	.38	.88
1.5	3/8	1016427	1.8	1.63	4.31	5.56	.63	.50	.66	1.34
3.0	1/2	1016436	4.3	2.00	6.13	8.13	1.00	.75	.91	2.00
5.0	5/8	1016445	8.6	2.50	7.75	10.63	1.19	1.00	1.25	2.63
8.5	3/4	1016454	15.4	3.00	9.31	12.31	1.50	1.25	1.41	3.13
10	7/8	1016463	37.0	4.00	13.88	17.50	1.81	1.72	1.63	4.69
15	1	1016472	39.0	4.00	13.25	17.50	2.13	2.00	2.13	4.69
25	1-1/4	1016481	72.0	5.00	16.00	20.75	2.38	2.25	2.31	5.25
35	1-1/2	1016490	72.0	5.00	16.00	20.75	2.38	2.25	2.31	5.25

\*Ultimate Load is 5 times the Working Load Limit. Individually Proof Tested to 2 times the Working Load Limit.

## AS-6 Eye & Hook

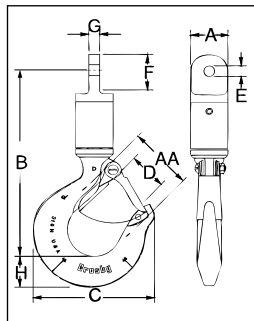

AS-6 EYE & HOOK				Dimensions (in)								Deformation Indicator AA	Replacement Latch Kit Stock No.
Working Load Limit (Tons)*	Wire Rope Size (in)	AS-6 Stock No.	Weight Each (lb)	A	B	C	D	E	F	G	H		
.45	1/8	1016502	.7	.88	4.38	2.86	.93	.25	.81	.25	.73	1.50	1096325
.75	1/4	1016513	1.5	1.31	5.56	3.16	.97	.38	.88	.31	.84	1.50	1096374
1.5	3/8	1016520	2.9	1.63	6.22	4.00	1.16	.66	1.34	.50	1.14	1.50	1096374
3.0	1/2	1016529	6.2	2.00	8.63	4.84	1.41	.91	2.00	.75	1.44	2.50	1096374
5.0	5/8	1016538	12.4	2.50	10.77	6.28	1.69	1.25	2.63	1.00	1.82	3.00	1096562
8.5	3/4	1016547	23.5	3.00	13.52	8.34	2.41	1.40	3.13	1.25	2.60	4.00	1096657
10	7/8	1016556	52.0	4.00	18.08	10.34	3.19	1.66	4.69	1.72	3.00	5.00	1096704
15	1	1016565	53.0	4.00	17.64	10.34	3.19	2.03	4.69	2.00	3.00	5.00	1096704
25	1-1/4	1016574	94.0	5.00	20.88	13.62	3.25	2.34	5.25	2.25	3.62	6.50	1090161
35	1-1/2	1016583	138.0	5.00	24.00	14.06	3.00	2.34	5.25	2.25	4.56	7.00	1090189

\*Ultimate Load is 5 times the Working Load Limit. Individually Proof Tested to 2 times the Working Load Limit.



**NOTE:** For swivels larger than 35 tons, or designed to meet the requirements of demanding applications such as subsea applications, please contact the Crosby Engineered Solutions. For additional information concerning custom design products, contact:  
 In U.S.A. - Crosby's Engineered Solutions at 1-800-777-1555, Fax (918) 834-5035.  
 In Europe - N.V. Crosby Europe at +32 15 75 71 25.

## AS-7 Bullet Style Jaw & Jaw

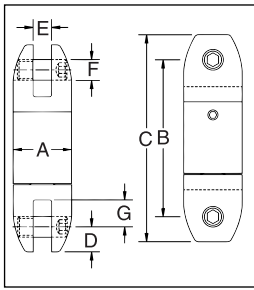

AS-7 BULLET STYLE JAW & JAW				Dimensions (in)						
Working Load Limit (Tons)*	Wire Rope Size (in)	AS-7 Stock No.	Weight Each (lb)	A	B	C	D	E	F	G
.45	1/8	1016604	.4	.88	2.38	3.13	.38	.25	.31	.40
.75	1/4	1016611	1.1	1.31	3.56	4.44	.44	.31	.38	.56
1.5	3/8	1016622	1.8	1.63	4.06	5.19	.56	.50	.44	.81
3.0	1/2	1016631	3.8	2.00	5.44	7.06	.81	.75	.63	.94
5.0	5/8	1016640	8.0	2.50	7.75	10.06	1.13	1.00	.88	1.56
8.5	3/4	1016649	14.5	3.00	9.88	12.38	1.25	1.31	1.00	2.13
10	7/8	1016652	40.0	4.00	13.13	16.75	1.75	1.75	1.50	3.25
15	1	1016658	40.0	4.00	13.13	16.75	1.75	1.75	1.50	3.25
25	1-1/4	1016662	84.0	5.00	15.94	20.75	2.38	2.00	2.00	3.69
35	1-1/2	1016667	84.0	5.00	15.94	20.75	2.38	2.00	2.00	3.69

\*Ultimate Load is 5 times the Working Load Limit. Individually Proof Tested to 2 times the Working Load Limit.

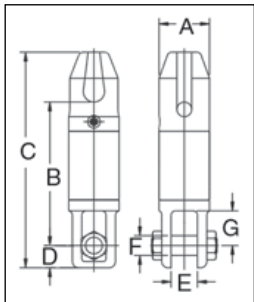

## AS-11 Thimble & Jaw

AS-11 THIMBLE & JAW				Dimensions (in)						
Working Load Limit (Tons)*	Wire Rope Size (in)	AS-11 Stock No.	Weight Each (lb)	A	B	C	D	E	F	G
8.5	3/4	1017020	18.0	3.00	8.66	13.00	1.34	1.56	1.19	2.09
15	1	1017029	42.0	4.00	11.66	17.53	1.75	1.78	1.50	3.50

\*Ultimate Load is 5 times the Working Load Limit. Individually Proof Tested to 2 times the Working Load Limit.

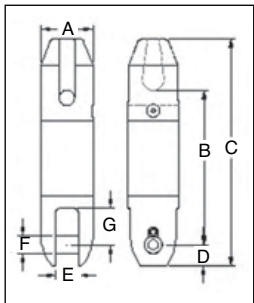

## AS-14 Thimble & Bullet

AS-14 THIMBLE & BULLET				Dimensions (in)						
Working Load Limit (Tons)*	Wire Rope Size (in)	AS-14 Stock No.	Weight Each (lb)	A	B	C	D	E	F	G
8.5	3/4	1017255	20.0	3.00	9.00	13.25	1.25	1.31	1.00	2.13
15	1	1017258	40.0	4.00	11.50	17.38	1.75	1.75	1.50	3.25
25	1-1/4	1017261	81.0	5.00	14.31	21.19	2.38	2.00	2.00	3.69

\*Ultimate Load is 5 times the Working Load Limit. Individually Proof Tested to 2 times the Working Load Limit.

## AS-17 Bullet Style Jaw & Jaw Slurry Swivel

The Crosby AS-17 Slurry Swivel is a zinc plated Bullet Type Swivel (AS-7), designed with two rubber lip style seals about the shaft. The threaded cap is sealed with a silicone sealant and secured with a set screw. The swivels are provided with an Alemite grease fitting for easy lubrication

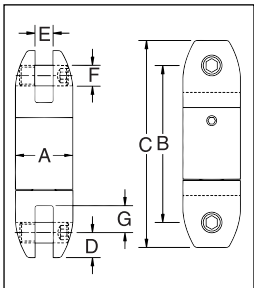

AS-17 BULLET JAW & SLURRY SWIVEL				Dimensions (in)						
Working Load Limit (Tons)*	Wire Rope Size (in)	AS-17 Stock No.	Weight Each (lb)	A	B	C	D	E	F	G
8.5	3/4	8013342	14.5	3.00	10.13	12.63	1.25	1.31	1.00	2.13
15	1	8013343	40.0	4.00	13.50	17.00	1.75	1.75	1.50	3.25
25	1-1/4	8013376	84.0	5.00	16.16	20.92	2.38	2.00	2.00	3.69
35	1-1/2	8013344	84.0	5.00	16.16	20.92	2.38	2.00	2.00	3.69
45	-	2016585	150.0	6.00	20.25	26.25	3.00	2.53	2.25	2.75

\*Ultimate Load is 5 times the Working Load Limit. Individually Proof Tested to 2 times the Working Load Limit.



For swivels larger than 35 tons, or for swivels designed to meet the requirements of demanding applications (i.e., subsea applications), please contact the Crosby Special Engineered Products Department. For additional information concerning custom design products, contact:  
 U.S.A., Crosby's Special Engineered Products Group at 1-800-777-1555, Fax (918) 834-5035  
 Europe, N.V. Europe at +32 15 75 71 25.



# S-4320 HOOK LATCH KIT

## WARNINGS & APPLICATION INSTRUCTIONS



(For Crosby 319N, 320N, and 322N, S-1327, and A-1339 Hooks)

### Important Safety Information - Read & Follow

- Always inspect hook and latch before using.
- Never use a latch that is distorted or bent.
- Always make sure spring will force the latch against the tip of the hook.
- Always make sure hook supports the load. The latch must never support the load (See Figures 1 & 2).
- When placing two (2) sling legs in hook, make sure the angle between the legs is less than 90° and if the hook or load is tilted, nothing bears against the bottom of this latch (See Figures 3 & 4).
- Latches are intended to retain loose sling or devices under slack conditions.
- Latches are not intended to be an anti-fouling device.
- When using latch for personnel lifting, select proper cotter pin (See Figure 5). See Step 7 below for proper installation instructions.
  - Never reuse a bent cotter pin.
  - Never use a cotter pin with a smaller diameter or different length than recommended in Figure 5.
  - Never use a nail, a welding rod, wire, etc., in place of recommended cotter pin.
  - Always ensure cotter pin is bent so as not to interfere with sling operation.
- Periodically inspect cotter pin for corrosion and general adequacy.

### WARNING

- Loads may disengage from hook if proper procedures are not followed.
- A falling load may cause serious injury or death.
- Hook must always support the load. The load must never be supported by the latch.
- See OSHA Rule 1926.1431(g)(1)(i)(A) and 1926.1501(g)(4)(iv)(B) for Personnel Hoisting by Crane or Derricks. A Crosby S-319N, S-320N, S-322N, S-1327, and A-1339 Hook with an S-4320 latch attached (when secured with cotter pin) may be used for lifting personnel.
- An S-4320 Latch is only to be used with a Crosby S-319N, S-320N, S-322N, S-1327, and A-1339 Hook.
- DO NOT use this latch in applications requiring non-sparking.
- Read and understand these instructions before using hook and latch.

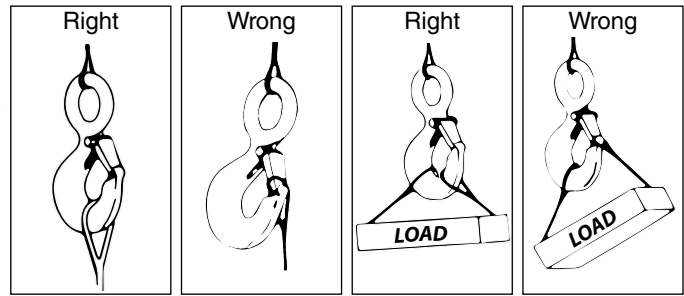

Figure 1

Figure 2

Figure 3

Figure 4

Figure 5

Hook Identification Code	Recommended Cotter Pin Dimensions (in)	
	Diameter	Length
D	1/8	3/4
F	1/8	3/4
G	1/8	1
H	3/16	1-1/4
I	1/4	1-1/2
J	5/16	2
K	5/16	2
L	3/8	3
N	3/8	3

† The current SS-4055 latch kit and the PL latch will not fit new 319N, 320N, or 322N hooks. They will continue to be offered in both styles to service existing hooks. Important – The new S4320 latch kit will not fit the old 319, 320, or 322 hooks.

### IMPORTANT – Instructions for Assembling S-4320 Latch on Crosby 320N Hooks

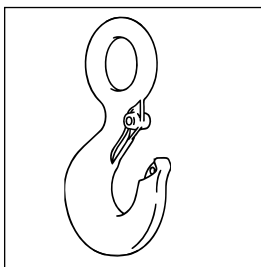

Step 1

1. Place hook at approximately a 45 degree angle with the cam up.

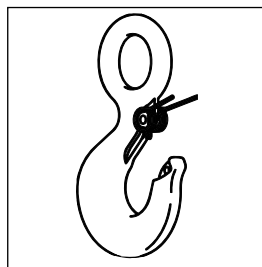

Step 2

2. Position coils of spring over cam with legs of spring pointing toward point of hook and loop of spring positioned down and lying against the hook.

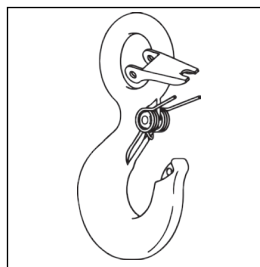

Step 3

3. Position latch to side of hook points. Slide latch onto spring legs between lockplate and latch body until latch is partially over hook cam. Then depress latch and spring until latch clears point of hook.

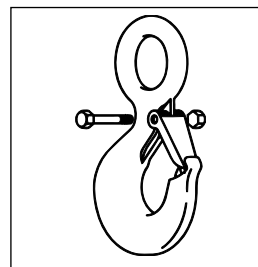

Steps 4, 5, & 6

4. Line up holes in latch with hook cam.  
5. Insert bolt through latch, spring, and cam.  
6. Tighten self-locking nut on one end of bolt.

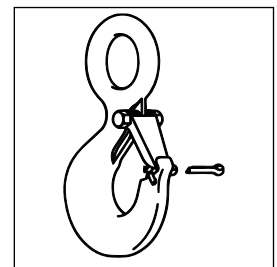

Step 7 – For Personnel Lifting

7. With latch in closed position and rigging resting in bowl of hook, insert cotter pin through hook tip and secure by bending prongs.

# Crosby® HOIST HOOKS

## WARNINGS & APPLICATION INSTRUCTIONS



⚠ WARNING

- Loads may disengage from hook if proper procedures are not followed.
- A falling load may cause serious injury or death.
- See OSHA Rule 1926.1431(g)(1)(i)(A) and 1926.1501(g)(4)(iv)(B) for personnel hoisting by cranes and derricks, and OSHA Directive CPL 2-1.36 - Interim Inspection Procedures During Communication Tower Construction Activities. A Crosby 319, L-320 or L-322 hook with a PL latch attached and secured with a bolt, nut and cotter pin (or toggle pin) may be used for lifting personnel. A Crosby 319N, L-320N or L-322N hook with an S-4320 latch attached and secured with cotter pin or bolt, nut and pin; or a PL-N latch attached and secured with toggle pin may be used for lifting personnel. A hook with a Crosby SS-4055 latch attached shall NOT be used for personnel lifting.
- See OSHA Directive CPL 2-1.36 - Crosby does not recommend the placement of lanyards directly into the positive locking Crosby hook when hoisting personnel. Crosby requires that all suspension systems (vertical lifelines / lanyard) shall be gathered at the positive locked load hook by use of a master link, or a bolt-type shackle secured with cotter pin.
- Threads may corrode and/or strip and drop the load.
- Remove securement nut to inspect or to replace L-322, S-3316, and S-3319 bearing washers (2).
- Hook must always support the load. The load must never be supported by the latch.
- Never apply more force than the hook's assigned Working Load Limit (WLL) rating.
- Read and understand these instructions before using hook.

**QUIC-CHECK®** Hoist hooks incorporate markings forged into the product which address two (2) **QUIC-CHECK®** features:

1. **Deformation Indicators** – Two strategically placed marks, one just below the shank or eye and the other on the hook tip, which allows for a **QUIC-CHECK®** measurement to determine if the throat opening has changed, thus indicating abuse or overload. **To check**, use a measuring device (i.e., tape measure) to measure the distance between the marks. The marks should align to either an inch or half-inch increment on the measuring device. If the measurement does not meet criteria, the hook should be inspected further for possible damage.
2. **Angle Indicators** – Indicates the maximum included angle which is allowed between two (2) sling legs in the hook. These indicators also provide the opportunity to approximate other included angles between two sling legs.



### IMPORTANT SAFETY INFORMATION - READ & FOLLOW

A visual periodic inspection for cracks, nicks, wear, gouges and deformation as part of a comprehensive documented inspection program, should be conducted by trained personnel in compliance with the schedule in ASME B30.10.

- For hooks used in frequent load cycles or pulsating loads, the hook and threads should be periodically inspected by Magnetic Particle or Dye Penetrant. (Note: Some disassembly may be required.)
- Never use a hook whose throat opening has been increased, or whose tip has been bent more than 10 degrees out of plane from the hook body, or is in any other way distorted or bent.

Note: A latch will not work properly on a hook with a bent or worn tip.

- Never use a hook that is worn beyond the limits shown in Figure 1.
- Remove from service any hook with a crack, nick, or gouge. Hooks with a nick or gouge shall be repaired by grinding lengthwise, following the contour of the hook, provided that the reduced dimension is within the limits shown in Figure 1. Contact Crosby Engineering to evaluate any crack.
- Never repair, alter, rework, or reshape a hook by welding, heating, burning, or bending.
- Never side load, back load, or tip load a hook. (Side loading, back loading and tip loading are conditions that damage and reduce the capacity of the hook). (See Figure 2.)
- Eye hooks, shank hooks and swivel hooks are designed to be used with wire rope or chain. Efficiency of assembly may be reduced when used with synthetic material.
- Do not swivel the L-322, S-3316, or S-3319 swivel hooks while supporting a load. These hooks are distinguishable by hex nuts and flat washers.
- The L-3322 swivel hook is designed to rotate under load. The L-3322 is distinguishable from the L-322 by use of a round nut designed to shield bearing.
- The frequency of bearing lubrication on the L-3322 depends upon frequency and period of product use as well as environmental conditions, which are contingent upon the user's good judgment.
- The use of a latch may be mandatory by regulations or safety codes; e.g., OSHA, MSHA, ANSI/ASME B30, Insurance, etc. (Note: When using latches, see instructions in "Understanding The Crosby Group Warnings" for further information.)
- Always make sure the hook supports the load. (See Figure 3). The latch must never support the load (See Figure 4).
- When multileg slings are placed in the base (bowl/saddle) of the hook, the maximum included angle between sling legs shall be 90 deg. The maximum sling leg angle with respect to the hook centerline for any rigging arrangement shall be 45 degrees. A collector ring, such as a link or shackle, should be used to maintain in-line load when more than two legs are placed in a hook or for angles greater than 45 degrees with respect to hook centerline. When more than two legs are placed in the hook bunching of the legs shall be avoided.
- See ASME B30.10 "Hooks" for additional information.

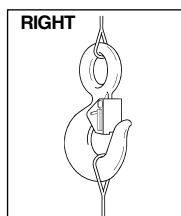
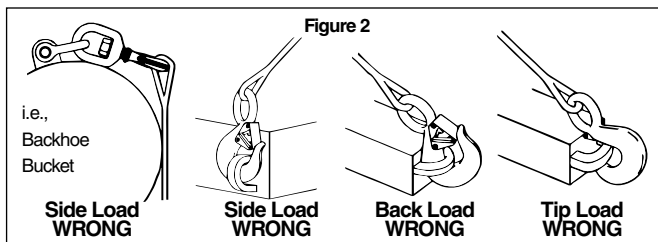
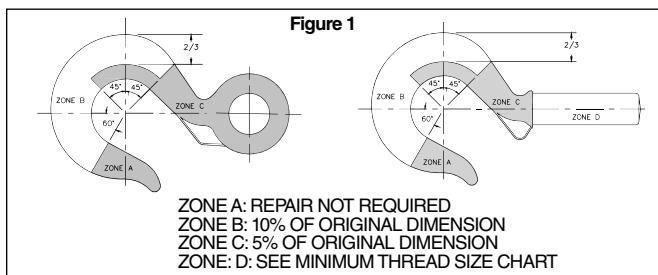

Figure 3

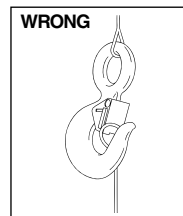

Figure 4

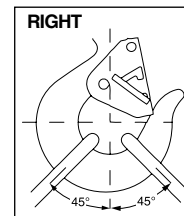

Figure 5

# READ AND UNDERSTAND THESE INSTRUCTIONS BEFORE USING HOOKS

## IMPORTANT – BASIC MACHINING AND THREAD INFORMATION

- Wrong thread and/or shank size can cause stripping and loss of load.
- The maximum diameter is the largest diameter, after cleanup, that could be expected after allowing for straightness, pits, etc.
- All threads must be Class 2 or better.
- The minimum thread length engaged in the nut should not be less than one (1) thread diameter. Install a properly sized retention device to secure the nut to the hook shank after the nut is properly adjusted at assembly. Nut retention devices such as set screws or roll pins are suitable for applications using anti-friction thrust bearings or bronze thrust washers. If the hook is intended for other applications that introduce a higher torque into the nut, a more substantial retaining device may be required.
- Hook shanks are not intended to be swaged on wire rope or rod. See S319SWG for hook designed for swaging.
- Hook shanks are not intended to be drilled (length of shank) and internally threaded.

- Crosby can not assume responsibility for, (A) the quality of machining, (B) the type of application, or (C) the means of attachment to the power source or load.
- Consult the Crosby Hook Identification & Working Load Limit Chart (See below) for the minimum thread size for assigned Working Load Limits (WLL).†
- Remove from service any Hook which has threads corroded more than 20% of the nut engaged length.

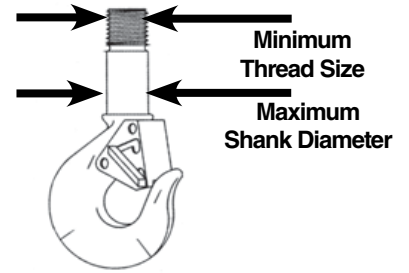

### CROSBY HOOK IDENTIFICATION & WORKING LOAD LIMIT CHART†

Hook Identification			Working Load Limit (t)						Frame Size	Maximum Shank Diameter after Machining (mm)	Minimum Thread Size	
319C 319CN L-320C L-320CN L-322C L-322CN	319AN L-320AN L-322A L-322AN 3319 L-3322B	319BN	319C 319CN L-320C L-320CN L-322C L-322CN	319A 319AN L-320A L-320AN L-322A L-322AN L-3322B	319BN	S-3319	S-3316	319C 319CN (Carbon)			319A 319AN (Alloy)	
DC	DA	DB	.75	1	.5	—	—	D	13.5	M12 x 1.25	M12 x 1.25	
FC	FA	FB	1	1.5	.6	—	.45	F	15.7	M16 x 2	M16 x 2	
GC	GA	GB	1.5	2	1	—	—	G	16.8	M16 x 2	M16 x 2	
HC	HA	HB	2	3	1.4	1.63	.91	H	20.6	M18 x 1.5	M18 x 1.5	
IC	IA	IB	3	*4.5 / 5	2.0	2.5	—	I	26.2	M22 x 2.5	M22 x 2.5	
JC	JA	JB	5	7	3.5	4.5	—	J	32.3	M27 x 2	M27 x 2	
KC	KA	KB	7.5	11	5.0	—	—	K	38.6	M30 x 1.5	M30 x 1.5	
LC	LA	LB	10	15	6.5	—	—	L	44.5	M40 x 1.5	M40 x 1.5	
NC	NA	NB	15	22	10	—	—	N	50.8	M50 x 1.5	M50 x 1.5	
OC	OA	—	20	30	—	—	—	O	63.5	M56 x 2	M56 x 2	
PC	PA	—	25	37	—	—	—	P	88.9	M70 x 1.5	M70 x 1.5	
SC	SA	—	30	45	—	—	—	S	88.9	M75 x 1.5	M75 x 1.5	
TC	TA	—	40	60	—	—	—	T	101.6	M85 x 2	M90 x 2	
UC	UA	—	50	75	—	—	—	U	114.3	M95 x 2	M100 x 2	
—	WA	—	—	100	—	—	—	W	155.4	—	M120 x 2	
—	XA	—	—	150	—	—	—	X	162.1	—	M140 x 2	
—	YA	—	—	200	—	—	—	Y	177.8	—	M160 x 2	
—	ZA	—	—	300	—	—	—	Z	218.9	—	M190 x 2	

\* 319AN, L-320AN, L-3322 and L-322AN are rated at 5 tons.

† Working Load Limit - The maximum mass or force which the product is authorized to support in general service when the pull is applied in-line, unless noted otherwise, with respect to the centerline of the product. This term is used interchangeably with the following terms: 1. WLL, 2. Rated Load Value, 3. SWL, 4. Safe Working Load, 5. Resultant Safe Working Load.

## Warning and Application Instructions For Crosby® Hook Latch Kit

### IMPORTANT SAFETY INFORMATION - READ & FOLLOW

- Always inspect hook and latch before using.
- Never use a latch that is distorted or bent.
- Always make sure spring will force the latch against the tip of the hook.
- Always make sure hook supports the load. The latch must never support the load (See Figures 1 & 2).
- When placing two (2) sling legs in hooks, make sure the angle between the legs is less the 90° and if the hook or load is tilted, nothing bears against the bottom of this latch (See Figures 3 & 4).
- Latches are intended to retain loose sling or devices under slack conditions.
- Latches are not intended to be an anti-fouling device.

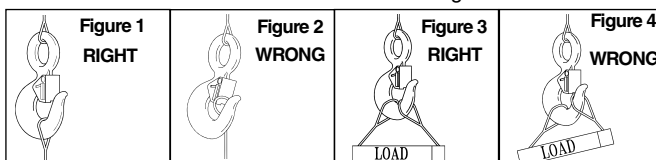

### WARNING

- Loads may disengage from hook if proper procedures are not followed.
- A falling load may cause serious injury or death.
- See OSHA Rule 1926.1431(g)(1)(i)(A) and 1926.1501(g)(4)(iv)(B) for personnel hoisting for cranes and derricks. Only a Crosby or McKissick hook with a PL Latch attached and secured with bolt, nut and cotter (or Crosby Toggle Pin) or a Crosby hook with a S-4320 Latch attached and secured with a cotter pin, or a Crosby SHUR-LOC® hook in the locked position may be used for any personnel hoisting. A hook with a Crosby SS-4055 latch attached shall NOT be used for personnel lifting.
- Hook must always support the load. The load must never be supported by the latch.
- DO NOT use this latch in applications requiring non-sparking.
- Read and understand these instructions before using hook and latch.



# McKissick® HOIST HOOKS

## WARNINGS & APPLICATION INSTRUCTIONS



L-320N Series



S-319 Series



L-322 Series  
Positioning  
Only



L-3322B Series

### ⚠ WARNING

- Loads may disengage from hook if proper procedures are not followed.
- A falling load may cause serious injury or death.
- See OSHA Rule 1926.1431(g)(1)(i)(A) and 1926.1501(g)(4)(iv) (B) for personnel hoisting by cranes and derricks, and OSHA Directive CPL 2-1.36 - Interim Inspection Procedures During Communication Tower Construction Activities. A Crosby 319, L-320 or L-322 hook with a PL latch attached and secured with a bolt, nut and cotter pin (or toggle pin) may be used for lifting personnel. A Crosby 319N, L-320N or L-322N hook with an S-4320 latch attached and secured with cotter pin or bolt, nut and pin; or a PL-N latch attached and secured with toggle pin may be used for lifting personnel. A hook with a Crosby SS-4055 latch attached shall NOT be used for personnel lifting.
- See OSHA Directive CPL 2-1.36 - Crosby does not recommend the placement of lanyards directly into the positive locking Crosby hook when hoisting personnel. Crosby requires that all suspension systems (vertical lifelines / lanyard) shall be gathered at the positive locked load hook by use of a master link, or a bolt-type shackle secured with cotter pin.
- Threads or Split-Nut may corrode and/or strip and drop the load.
- Remove securement nut to inspect or to replace S-322 and S-3319 bearing washers (2).
- Hook must always support the load. The load must never be supported by the latch.
- Never apply more force than the hook's assigned Working Load Limit (WLL) rating.
- Read and understand these instructions before using hook.

**QUIC-CHECK®** Hoist hooks incorporate markings forged into the product which address two (2) QUIC-CHECK® features:

**Deformation Indicators** - Two strategically placed marks, one just below the shank or eye and the other on the hook tip, which allows for a QUIC-CHECK® measurement to determine if the throat opening has changed, thus indicating abuse or overload.



**To check**, use a measuring device (i.e., tape measure) to measure the distance between the marks. The marks should align to either an inch or half-inch increment on the measuring device. If the measurement does not meet criteria, the hook should be inspected further for possible damage.

**Angle Indicators** - Indicates the maximum included angle which is allowed between two (2) sling legs in the hook. These indicators also provide the opportunity to approximate other included angles between two sling legs.

### IMPORTANT SAFETY INFORMATION - READ & FOLLOW

- A visual periodic inspection for cracks, nicks, wear, gouges and deformation as part of a comprehensive documented inspection program, should be conducted by trained personnel in compliance with the schedule in ASME B30.10.
- For hooks used in frequent load cycles or pulsating loads, the hook and threads should be periodically inspected by Magnetic Particle or Dye Penetrant. (Note: Some disassembly may be required.)
- Never use a hook whose throat opening has been increased, or whose tip has been bent more than 10 degrees out of plane from the hook body, or is in any other way distorted or bent. **Note: A latch will**

not work properly on a hook with a bent or worn tip.

- Never use a hook that is worn beyond the limits shown in Figure 1.
- Remove from service any hook with a crack, nick, or gouge. Hooks with a nick or gouge shall be repaired by grinding lengthwise, following the contour of the hook, provided that the reduced dimension is within the limits shown in Figure 1. Contact Crosby Engineering to evaluate any crack.
- Remove from service any hook which has threads corroded more than 20% of the nut engagement length.
- Never repair, alter, rework, or reshape a hook by welding, heating, burning, or bending.
- Never side load, back load, or tip load a hook. (Side loading, back loading and tip loading are conditions that damage and reduce the capacity of the hook). (See Figure 2.)
- Eye hooks, shank hooks and swivel hooks are designed to be used with wire rope or chain. Efficiency of assembly may be reduced when used with synthetic material.
- Do not swivel the L-322 or S-3319 swivel hooks while supporting a load. These hooks are distinguishable by hex nuts and flat washers.
- The L-3322 swivel hook is designed to rotate under load. The L-3322 is distinguishable from the L-322 by use of a round nut designed to shield bearing.
- The frequency of bearing lubrication on the L-3322 depends upon frequency and period of product use as well as environmental conditions, which are contingent upon the user's good judgment.
- The use of a latch may be mandatory by regulations or safety codes; e.g., OSHA, MSHA, ASME B30, Insurance, etc.. (Note: When using latches, see instructions in "Understanding: The Crosby Group Warnings" for further information.)
- Always make sure the hook supports the load (See Figure 3). The latch must never support the load (See Figure 4).
- When multileg slings are placed in the base (bowl/saddle) of the hook, the maximum included angle between sling legs shall be 90 deg. The maximum sling leg angle with respect to the hook centerline for any rigging arrangement shall be 45 degrees. A collector ring, such as a link or shackle, should be used to maintain in-line load when more than two legs are placed in a hook or for angles greater than 45 degrees with respect to hook centerline. When more than two legs are placed in the hook bunching of the legs shall be avoided.
- Reference Crosby's Hoist Hook Warning and Application Information for basic machining and minimum thread size.
- See ASME B30.10 "Hooks" for additional information.

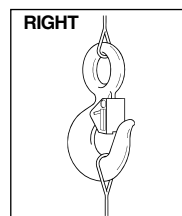
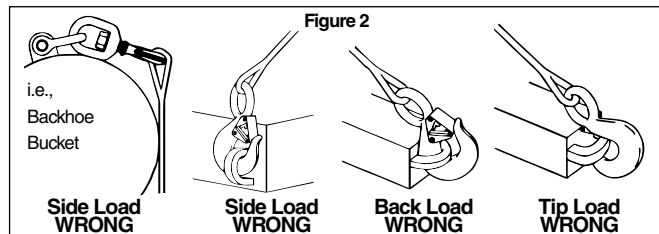
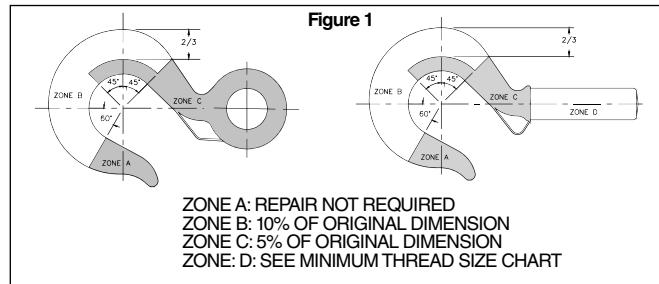

Figure 3

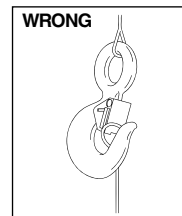

Figure 4

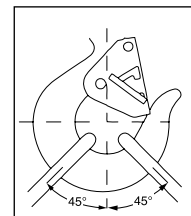

Figure 5

### Removal of Split-Nut assembly (Reference Figure A):

- Remove vinyl cover.
- Remove spring retaining ring.
- Slide steel keeper ring off split nuts **▲ (CAUTION: Removal of keeper ring will allow split nut halves to fall from hook shank).**
- Remove split nut halves.

### Inspection of split nut assembly and hook shank interface area (Reference Figure B):

- Inspect hook shank and split nut for signs of deformation on and adjacent to the load bearing surfaces.
- Inspect outside corner of hook shank load bearing surface to verify the corner is sharp.
- Verify retaining ring groove will allow proper seating of the retaining ring.
- Inspect retaining ring for corrosion or deformation. Remove from service any retaining ring that has excessive corrosion or is deformed.
- Use fine grit emery or crocus cloth to remove any corrosion from machined hook shank and split nut assembly.
- Follow inspection recommendations listed in this document under IMPORTANT SAFETY INFORMATION.
- If corrosion is present on the nut / shank interface area and deterioration or degradation of the metal components is evident, further inspection is required.
  - The use of a feeler gauge is required to properly measure the maximum allowable gap width between the split nut inside diameters and shank outside diameters.
  - With one split nut half seated against the hook shank, push the nut to one side and measure the maximum gaps as shown in Figure B. The hook should be measured in four places, 90-degrees apart.
  - Repeat above inspection procedure with other half of split nut.
  - Remove from service any hook and split nut assembly that exhibits a gap greater than 0.030".

### Installation of split nut assembly (Reference Figure A):

- Coat hook shank and inside of split nut with an anti-seize compound or heavy grease.
- Install split nut halves onto shank. The flanged bottom of the split nut should be closest to the hook shoulder.

- Slide steel keeper ring over split nut halves. Verify the split nut halves properly seat against the load bearing surface of the hook shank and the steel keeper ring seats against the flange of the split nut.
- Install retaining ring onto split nut halves. Verify the retaining ring seats properly in the retaining ring groove on the outside diameter of the split nut assembly.
- Install vinyl cover over split nut and hook shank assembly.
- Verify all fasteners are correctly installed.
- Always use Genuine Crosby replacement parts.

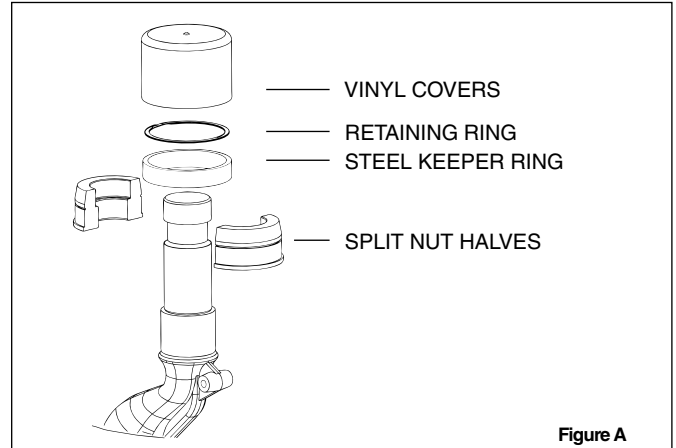

Figure A

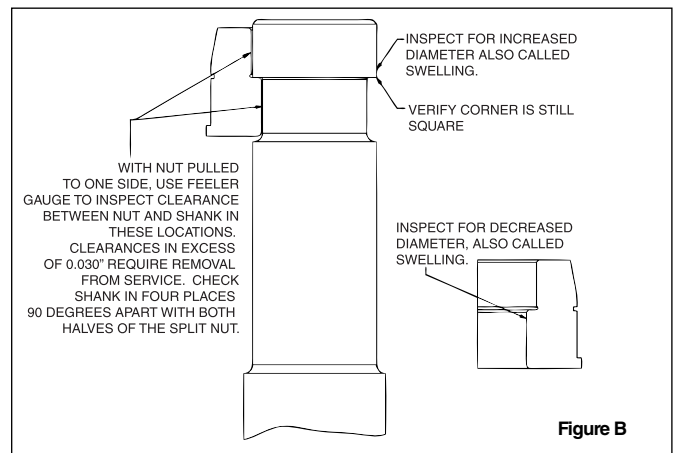
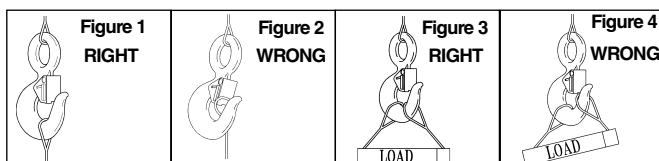

Figure B

## Warning and Application Instructions For McKISSICK® Hook Latch Kit

### IMPORTANT SAFETY INFORMATION - READ & FOLLOW

- Always inspect hook and latch before using.
- Never use a latch that is distorted or bent.
- Always make sure spring will force the latch against the tip of the hook.
- Always make sure hook supports the load. The latch must never support the load. (See Figures 1 & 2)
- When placing two (2) sling legs in hooks, make sure the angle between the legs is less than 90° and if the hook or load is tilted, nothing bears against the bottom of this latch. (See Figures 3 & 4)
- Latches are intended to retain loose sling or devices under slack conditions.
- Latches are not intended to be an anti-fouling device.



### ▲ WARNING

- Loads may disengage from hook if proper procedures are not followed.
- A falling load may cause serious injury or death.
- See OSHA Rule 1926.1431(g)(1)(i)(A) and 1926.1501(g)(4)(iv) (B) for personnel hoisting for cranes and derricks. Only a Crosby or McKissick hook with a PL Latch attached and secured with bolt, nut and cotter (or Crosby Toggle Pin) or a Crosby hook with a S-4320 Latch attached and secured with a cotter pin, or a Crosby SHUR-LOC® hook in the locked position may be used for any personnel hoisting. A hook with a Crosby SS-4055 latch attached shall NOT be used for personnel lifting.
- Hook must always support the load. The load must never be supported by the latch.
- Do not use this latch in applications requiring non-sparking.
- Read and understand these instructions before using hook and latch.

# Crosby® / BULLARD® GOLDEN GATE® HOOKS

## WARNINGS & APPLICATION INSTRUCTIONS



**QUIC-CHECK®** Hoist Hooks incorporate markings forged into the product which address two (2) **QUIC-CHECK®** features:

**Deformation Indicators** – Two strategically placed marks, one just below the shank or eye and the other on the hook tip, which allows for a **QUIC-CHECK®** measurement to determine if the throat opening has changed, thus indicating abuse or overload.

**To check**, use a measuring device (i.e., tape measure) to measure the distance between the marks. The marks should align to either an inch or half-inch increment on the measuring device. If the measurement does not meet criteria, the hook should be inspected further for possible damage.

**Angle Indicators** – Indicates the maximum included angle which is allowed between two (2) sling legs in the hook. These indicators also provide the opportunity to approximate other included angles between two sling legs.



### IMPORTANT SAFETY INFORMATION - READ & FOLLOW

- A visual periodic inspection for cracks, nicks, wear, gouges and deformation as part of a comprehensive documented inspection program, should be conducted by trained personnel in compliance with the schedule in ANSI B 30.10.
- For hooks used in frequent load cycles or pulsating loads, the hook and threads should be periodically inspected by Magnetic Particle or Dye Penetrant. (Note: Some disassembly may be required.)
- See WARNING box and Figure 6 for special instructions for securing the nut to the shank at assembly.
- Never use a hook whose throat opening has been increased, or whose tip has been bent more than 10 degrees out of plane from the hook body, or is in any other way distorted or bent. **Note: A gate will not work properly on a hook with a bent or worn tip.**
- Manual - closing gates must be completely closed for the lock to work.
- Never use a hook that is worn beyond the limits shown in Figure 1.
- Remove from service any hook with a crack, nick, or gouge. Hooks with a nick or gouge shall be repaired by grinding lengthwise, following the contour of the hook, provided that the reduced dimension is within the limits shown in Figure 1. Contact Crosby Engineering to evaluate any crack.
- Never repair, alter, rework, or reshape a hook by welding, heating, burning, or bending.
- Never side load, back load, or tip load a hook. Side loading, back loading and tip loading are conditions that damage and reduce the capacity of the hook (See Figure 2).
- Eye hooks, shank hooks and swivel hooks are designed to be used with wire rope or chain. Efficiency of assembly may be reduced when used with synthetic material.

⚠ WARNING

- Loads may disengage from hook if proper procedures are not followed.
- A falling load may cause serious injury or death.
- Before using, inspect the hook and gate daily to ensure it is in proper operating condition.
- Failure to properly insert the pin could result in the load falling.
- All Golden Gate® Hooks with threaded shanks require a pin to secure the nut to the shank. This pin prevents the nut from backing off or unscrewing from the threads and causing the load to drop.
- If the pin and nut are removed from the shank to replace any hook components, the pin and nut must be installed before use.
 

**NOTE: 1.** If a solid pin was used, the old pin “must” be discarded and a new pin inserted to secure the nut to the shank.

**2.** If a spring pin (coil type) was used, it may be reused provided that the spring pin and / or the drill hole was not damaged.
- The gate is not a load-bearing device. Do not allow the sling or other loads to bear against the gate.
- Threads may corrode and / or strip and drop the load.
- Hands, fingers and body should be kept away from the hook and load whenever possible.
- Never apply more force than the hook’s assigned Working Load Limit (WLL) rating.
- Read and understand these instructions before using.

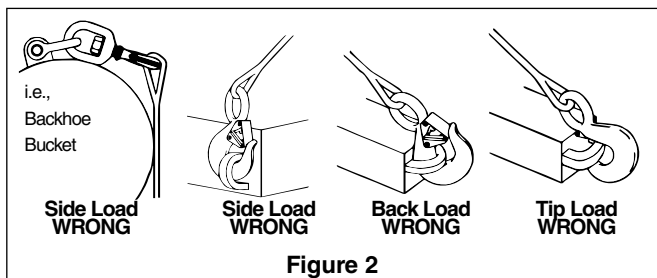
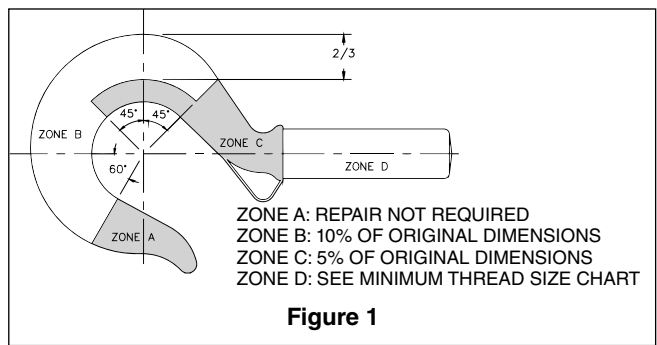



- The use of a latch may be mandatory by regulations or safety codes: e.g., OSHA, MSHA, ASME B30, Insurance etc.
- Always make sure the hook supports the load (See Figure 3). The gate must never support the load (See Figure 4).
- When multileg slings are placed in the base (bowl/saddle) of the hook, the maximum included angle between sling legs shall be 90 deg. The maximum sling leg angle with respect to the hook centerline for any rigging arrangement shall be 45 degrees. A collector ring, such as a link or shackle, should be used to maintain in-line load when more than two legs are placed in a hook or for angles greater than 45 degrees with respect to hook centerline. When more than two legs are placed in the hook bunching of the legs shall be avoided.
- See ASME B30.10 "Hooks" for additional information.
- If any of the following conditions exist, remove hook from service immediately and repair with genuine Crosby / Bullard Golden Gate® hook parts or replace the hook.
  - The gate does not lock in the closed position.
  - The gate is worn, deformed, inoperative, or fails to bridge the hook throat opening.
  - Load pins or bolts in the chain connectors are worn or bent.

- When hook is used to support a hoist, the weight of the hoist must be deducted from the assigned hook Working Load Limit.
- The rated capacity of chain connector hook assemblies must equal or exceed the capacity of the hoist.

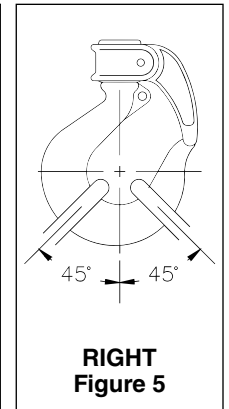
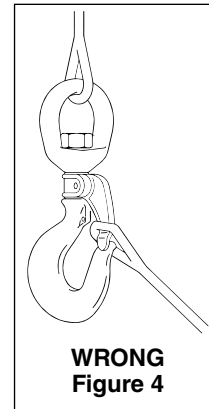
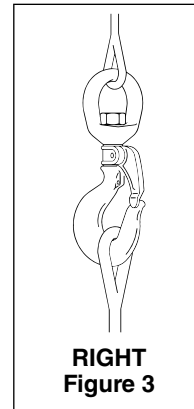

### Important – Basic Machining and Thread Information – Read and Follow

- Wrong thread and/or shank size can cause stripping and loss of load.
- The maximum diameter is the largest diameter that will fit into the gate.
- All threads must be Class 2 or better.
- The minimum thread length engaged in the nut should not be less than one (1) thread diameter.
- All nuts must be secured to the shank by cross drilling the nut and threaded shank and inserting the appropriate coil type spring pin (See WARNING box and Figure 6 for special instructions).
- Coil type spring pin must be as long as the distance across the nut flats or diameter (See Figure 6).
- Consult the Crosby / Bullard Golden Gate® Hook Identification and Working Load Limit Chart (See below) for the coil type spring pin diameter.
- Remove any hook from service that requires a larger coil type spring than that shown in the chart below.

- Hook shanks are not intended to be swaged on wire rope or rod.
- Hook shanks are not intended to be drilled and internally threaded.
- Crosby cannot assume responsibility for:
  - (A) the quality of machining,
  - (B) the type of application, or
  - (C) the means of attachment to the power source or load.
- Consult the Crosby/Bullard Golden Gate® Hook Identification & Working Load Limit Chart (below) for the minimum thread size for assigned Working Load Limits (WLL). +
- Remove from service any hook which has threads corroded more than 20% of the nut engaged length.

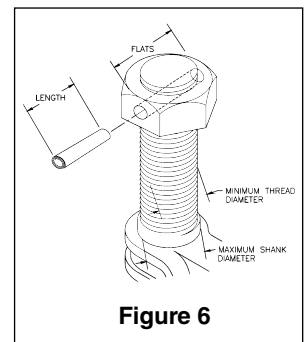

### Crosby® / Bullard Golden Gate® Hook Identification and Working Load Limit Chart

Hook / Gate Size	Working Load Limit ** + (Tons)	Maximum Shank Diameter (in)	Minimum Thread Size	Spring* Pin Size (in)	Drilled Hole Size (in)	Hook / Gate Size	Working Load Limit (Tons)	Maximum Shank Diameter (in)	Minimum Thread Size	Spring* Pin Size (in)	Drilled Hole Size (in)
1	.5	—	—	—	—	11	9.2	1.497	1-1/2 - 6 UNC	5/16	.308 / .319
2	1.0	.498	1/2 - 13 UNC	1/8	.124 / .129	12	12.3	1.622	1-5/8 - 5-1/2 UNC	5/16	.308 / .319
3	1.4	.559	9/16 - 12 UNC	1/8	.124 / .129	13	15.0	1.747	1-3/4 - 5 UNC	3/8	.370 / .383
4	1.7	.623	5/8 - 11 UNC	1/8	.124 / .129	14	18.5	1.997	2 - 4-1/2 UNC	3/8	.370 / .383
5	2.3	.747	3/4 - 10 UNC	5/32	.155 / .160	16	24.7	2.747	2-3/4 - 4 UNC	1/2	.493 / .510
6	4.0	.872	7/8 - 9 UNC	3/16	.185 / .192	16-A	33.0	2.747	2-3/4 - 4 UNC	1/2	.493 / .510
7	4.2	.997	1 - 8 UNC	3/16	.185 / .192	17	49.5	3.996	4 - 4 UNC	3/4	.743 / .760
8	5.5	1.122	1-1/8 - 7 UNC	1/4	.247 / .256	17-A	66.0	3.996	4 - 4 UNC	3/4	.743 / .760
9	7.2	1.247	1-1/4 - 7 UNC	1/4	.247 / .256	—	—	—	—	—	—

\* Heavy Duty Coil Type Spring Pin.

\*\* Minimum ultimate strength is 4 times the Working Load Limit.

+ Working Load Limit - The maximum mass or force which the product is authorized to support in general service when the pull is applied in-line, unless noted otherwise with respect to centerline of the product. This term is used interchangeably with the following terms: 1. WLL, 2. Rated Load Value, 3. SWL, 4. Safe Working Load, 5. Resultant Safe Working Load. Ultimate Load is 4 times the Working Load.

# Crosby® WELD-ON HOOKS

## WARNINGS & APPLICATION INSTRUCTIONS



BH-313

### IMPORTANT SAFETY INFORMATION - READ & FOLLOW

- Weld-On hooks are to only be welded to a structure, equipment or machinery in an area (load point) approved by the original equipment manufacturer. (Some manufacturers may not approve the modification of their product.)
- For hydraulic excavator lift capacity rating, refer to SAE standard J1097.
- A visual periodic inspection for cracks, nicks, wear, gouges and deformation as part of a comprehensive documented inspection program, should be conducted by trained personnel.
- A visual periodic inspection of the weld should be performed. Check the weld visually, or use a suitable NDE method if required.
- As excavator buckets are not specifically designed for constant use with excavator hooks, we recommend regular and very thorough inspection of the excavator bucket welding area to ensure no distortion has been made to the work area.
- Never use a hook whose throat opening has been increased, or whose tip has been bent more than 10 degrees out of plane from the hook body, or is in any other way distorted or bent.

**Note: A latch will not work properly on a hook with a bent or worn tip.**

- Never use a hook that is worn beyond the limits shown in Figure 1.
- Remove from service any hook with a crack, nick, or gouge. Hooks with a nick or gouge shall be repaired by grinding lengthwise, following the contour of the hook, provided that the reduced dimension is within the limits shown in Figure 1. Contact Crosby Engineering to evaluate any crack.
- Never repair, alter, rework, or reshape a hook by welding, heating, burning, or bending.
- Always make sure the hook supports the load. The load is to be applied within the range shown in Figure 2. The latch must never support the load (See Figure 3).
- Never side load (See Figure 4), or tip load (See Figure 5) a hook.
- The use of a latch may be mandatory by regulations or safety codes; e.g., OSHA, MSHA, ANSI/ASME B30, Insurance, etc. (Note: When using latches, see instructions in "Understanding: The Crosby Group Warnings" for further information).
- Ensure latch functions properly. Use only genuine Crosby replacement parts.
- Never attach more than one sling directly in hook. For collecting two or more slings to the hook, use proper hardware.
- See ASME B30.10 "Hooks" for additional information.

**⚠ WARNING**

- Loads may disengage from hook if proper procedures are not followed.
- A falling load may cause serious injury or death.
- Hook must always support the load. The load must never be supported by the latch.
- Never apply more force than the hook's assigned Working Load Limit (WLL) rating.
- Do not use Crosby weld-on hook for personnel hoisting. See OSHA Rule 1926.1431(g)(1)(i)(A) and 1926.1501(g)(4)(iv)(B).
- Read and understand these instructions before welding on, or using hook.

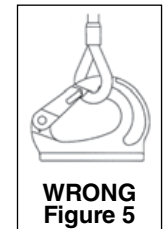
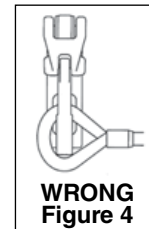
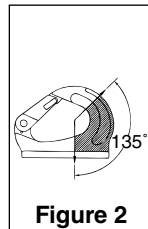
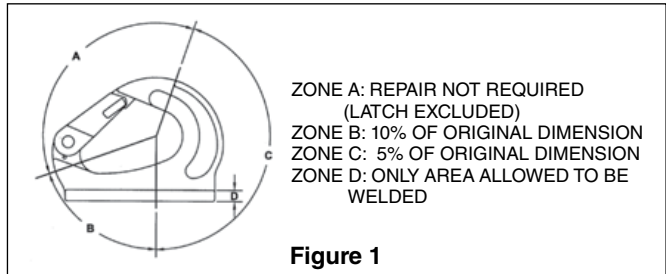

- The strength of the weld-on hook depends upon the method of attachment. Extreme care must be used in choice of support as well as during the attachment process.
- The support structure that the hook is attached to must be of suitable size, composition and quality to support the anticipated loads of all operating positions. The required support structure material thickness for a given application is dependent on variables such as unsupported length and material strength, and should be determined by a qualified individual. Minimum plate thickness required to support the welds are shown in Table 1.

TABLE 1				
Working Load Limit (t)	Minimum Plate Thickness (in)	Minimum Fillet Size All Around (in)	Minimum Plate Thickness (mm)	Minimum Fillet Size All Around (mm)
1	3/16	3/16	5	5
2	1/4	1/4	6	6
3	5/16	5/16	8	8
4	5/16	5/16	8	8
5	3/8	3/8	10	10
8	1/2	1/2	13	13
10	1/2	1/2	13	13

- Position the hook to ensure that the load is applied in the plane of the hook, and the load is supported by the hook in all operating positions. Ensure that the hook does not interfere with the operation of other mechanisms or cause pinch points.
- Ensure that the maximum gap between hook base and support does not exceed 1/8". Modify the support structure if required to reduce gap.
- When welding hook to carbon or low alloy steels (less than .40% carbon), the following welding recommendations are to be followed. For welding hook to other grades of steel, a qualified weld procedure must be developed. Crosby hook material is AISI 8622 modified.
- Welding is to be performed by a qualified welder using qualified procedure in accordance with American Welding Society (AWS), and/or American Society of Mechanical Engineers (ASME) requirements.
- Welding electrode to be in accordance with AWS A5.4 E-312-16. Observe the electrode manufacturer's recommendations.
- Welding preheat range outlined below.
  - Minimum preheat temperature: 212°F (100°C)
  - Maximum temperature: 716°F (380°C)
- Before welding, the surface to be welded on, including the hook and support structure, must be clean and free from rust, grease and paint.
- Fillet weld leg size should be of minimum shown in Table 1, page 148. Weld profiles to be in accordance with AWS. Weld size is measured by length of leg.
- Welding should be carried out completely around base in a minimum of two passes to ensure adequate root penetration at the base of the hook.
- Do not rapidly cool the weld.
- After welding, a visual inspection of the weld should be performed prior to painting.
- No cracks, pitting, inclusions, notches or undercuts are allowed. If doubt exists, use a suitable NDE method, such as Magnetic Particle or Liquid Penetrant to verify.
- If repair is required on weld, grind out defect and re-weld using original qualified procedure.
- After welding, the assembly should be proof tested before putting into service.

### Important – Instructions for Assembling S-4313 Latch on BH-313 Weld-On Hook

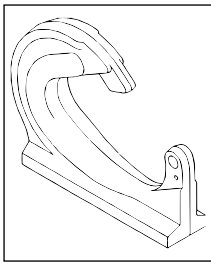

#### Step 1

1. Place hook flat on work surface as shown.

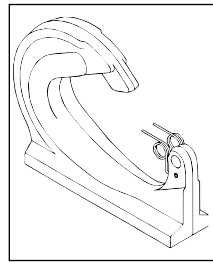

#### Step 2

#### Hook sizes 1 to 3 tons

2. Position coils of spring over hook cam, with legs of spring pointing towards hook tip and coil of spring positioned down as shown.

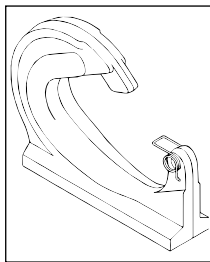

#### Step 2A

#### Hook sizes 4 to 10 tons

2A. Spread legs of spring and place into drilled hole. Position coils of spring over hook cam, with end of spring pointing toward hook tip as shown.

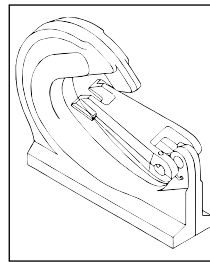

#### Step 3

3. Position latch over spring, aligning latch ears and spring coil. On pin hole side of latch, insert non-grooved end of latch pin through hole in latch and through spring until contact is made with hook body (a small punch may be required for proper alignment).

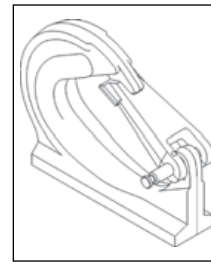

#### Step 4

4. Align holes in latch with holes in cam of hook. Continue pushing the pin through hook, spring and latch.

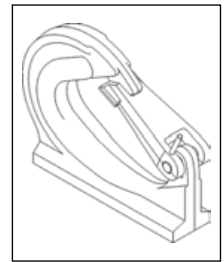

#### Step 5

5. Insert roll-pin into latch, driving it in with a hammer, while ensuring that latch pin groove is in alignment.



# Crosby® HOOK LATCH KIT

## WARNINGS & APPLICATION INSTRUCTIONS

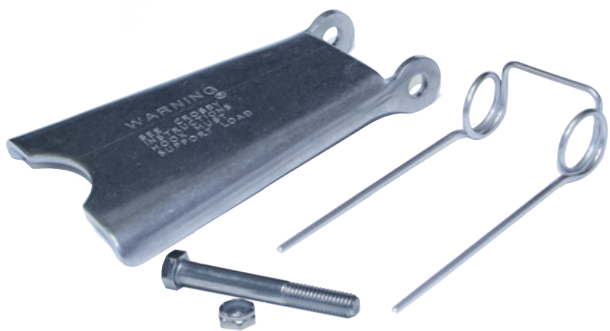

SS-4055

**⚠ WARNING**

- Loads may disengage from hook if proper procedures are not followed.
- A falling load may cause serious injury or death.
- See OSHA Rule 1926.1431(g)(1)(i)(A) and 1962.1501(g)(4)(iv)(B) A hook and this style latch must not be used for lifting personnel.
- Hook must always support the load. The load must never be supported by the latch.
- Read and understand these instructions before using hook and latch.

### IMPORTANT SAFETY INFORMATION - READ & FOLLOW

- Always inspect hook and latch before using.
- Never use a latch that is distorted or bent.
- Always make sure spring will force the latch against the tip of the hook.
- Always make sure hook supports the load. The latch must never support the load (See Figures 1 & 2).
- When placing two (2) sling legs in hook, make sure the angle between legs is small enough and the legs are not tilted so that nothing bears against the bottom of the latch (See Figures 3 & 4).
- Latches are intended to retain loose sling or devices under slack conditions.
- Latches are not intended to be an anti-fouling device.

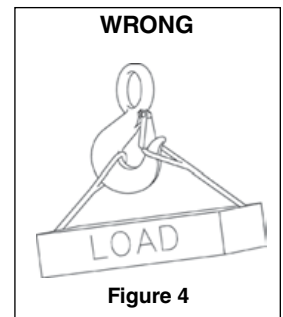
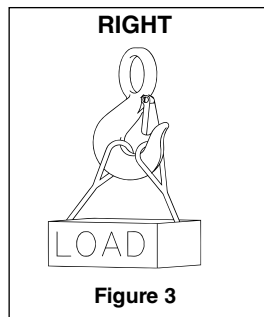
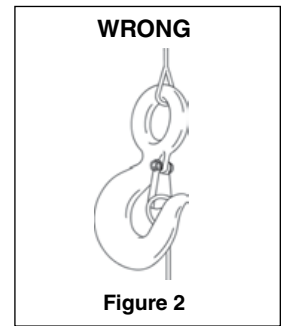
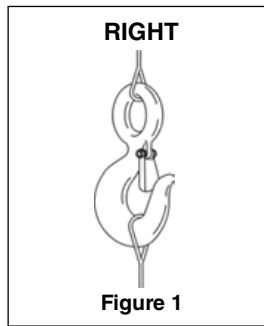

### IMPORTANT – Instructions for Assembling Model SS-4055 Latch on Crosby Hooks

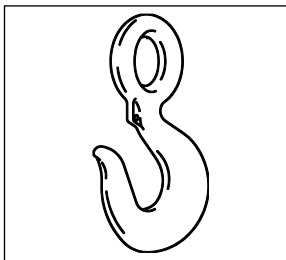

**Step 1**

1. Place hook at approximately a 45 degree angle with the cam up.

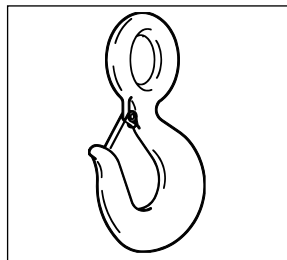

**Step 2**

2. Position coils of spring over cam with tines of spring pointing toward point of hook and loop of spring positioned down and lying against the hook.

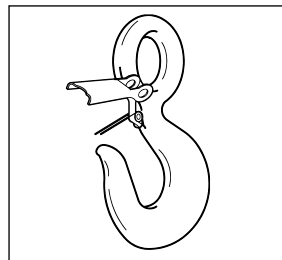

**Step 3**

3. Position latch over tines of spring with ears partially over hook cam. Swing latch to one side of hook, point and depress latch and spring until latch clears point of hook.

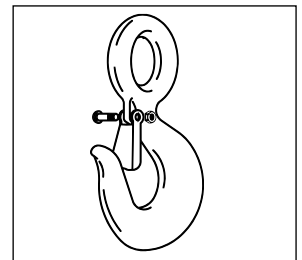

**Steps 4, 5, & 6**

4. Line up holes in latch with hook cam.  
5. Insert bolt through latch, spring, and cam.  
6. Tighten self-locking nut on one end of bolt.

# Crosby® MODEL PL HOOK LATCH KIT

## WARNINGS & APPLICATION INSTRUCTIONS

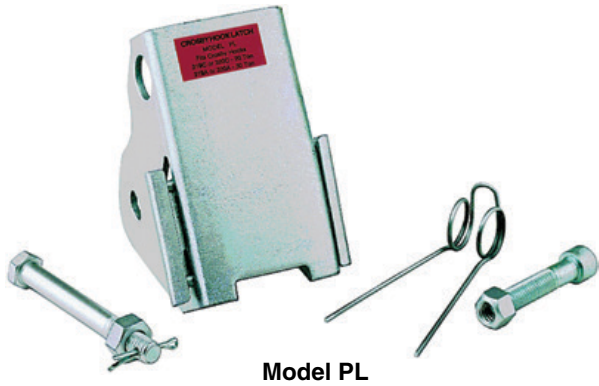

**⚠ WARNING**

- Loads may disengage from hook if proper procedures are not followed.
- A falling load may cause serious injury or death.
- See OSHA Rule 1926.1431(g)(1)(i)(A) and 1926.1501(g)(4)(iv)(B) for Personnel Hoisting by Cranes or Derricks. A Crosby or McKissick Hook with a positive Locked PL or S-4320 Latch may be used to Lift Personnel.
- Hook must always support the load. The load must never be supported by the latch.
- **DO NOT** use this latch in applications requiring non-sparking.
- Read and understand these instructions before using hook and latch.

### IMPORTANT SAFETY INFORMATION - READ & FOLLOW

(Pat. USA & Canada)

- Always inspect hook and latch before using.
- Never use a latch that is distorted or bent.
- Always make sure spring will force the latch against the tip of the hook.
- Always make sure hook supports the load. The latch must never support the load (See Figures 1 & 2).
- When placing two (2) sling legs in hook, make sure the angle between the legs is less than 90° and if the hook or load is tilted, nothing bears against the bottom of this latch (See Figures 3 & 4).
- Latches are intended to retain loose sling or devices under slack conditions.
- Latches are not intended to be an anti-fouling device.

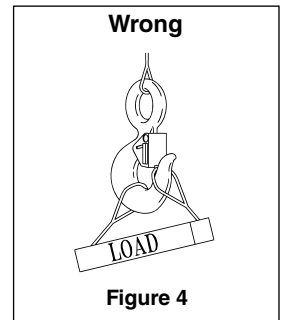
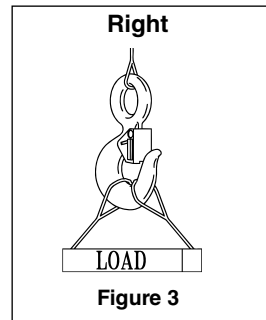
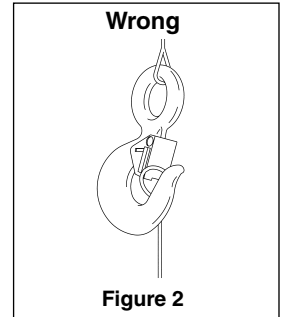
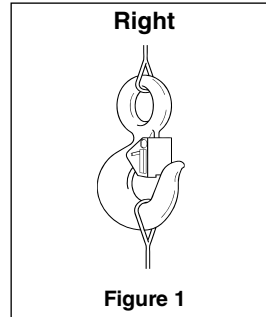

### IMPORTANT - Instructions for Assembling Model PL Latch on Crosby or McKissick Hooks

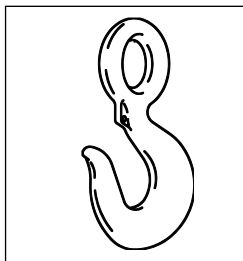

**Step 1**

1. Place hook at approximately a 45 degree angle with the cam up.

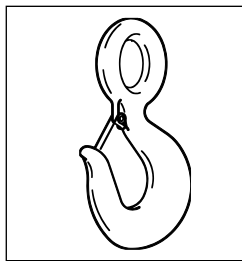

**Step 2**

2. Position coils of spring over cam with legs of spring pointing toward point of hook and loop of spring positioned down and lying against the hook.

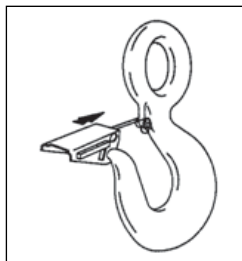

**Step 3**

3. Position latch to side of hook points. Slide latch onto spring legs between lockplate and latch body until latch is partially over hook cam. Then depress latch and spring until latch clears point of hook.

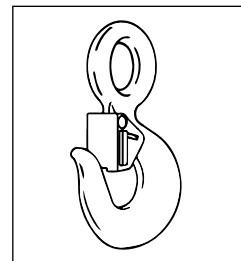

**Steps 4, 5, & 6**

4. Line up holes in latch with hook cam.  
5. Insert bolt through latch, spring, and cam.  
6. Tighten self-locking nut on one end of bolt.

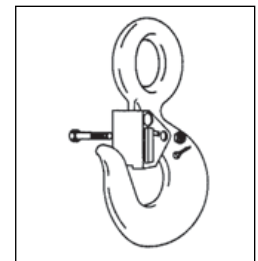

**Step 7 — For Personnel Lifting**

7. With latch in closed position and rigging resting in bowl of hook, insert bolt through latch and secure with nut and cotter pin. When bolt, nut and cotter pin are not being used, store them in a designated place upon the personnel platform.

## Crosby® MODEL PL-N/O HOOK LATCH KIT

### WARNINGS & APPLICATION INSTRUCTIONS

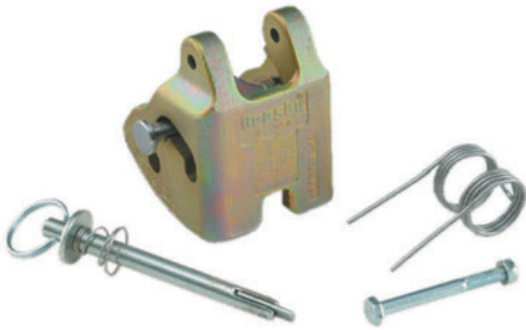

Model PL-N/O

#### IMPORTANT SAFETY INFORMATION - READ & FOLLOW

- Always inspect hook and latch before using.
- Never use a latch that is distorted or bent.
- Always make sure spring will force the latch against the tip of the hook.
- Always make sure hook supports the load. The latch must never support the load (See Figures 1 & 2).
- When placing two (2) sling legs in hook, make sure the angle between the legs is less than 90° and if the hook or load is tilted, nothing bears against the bottom of this latch (See Figures 3 & 4).
- Latches are intended to retain loose sling or devices under slack conditions.
- Latches are not intended to be an anti-fouling device.

**⚠ WARNING**

- Loads may disengage from hook if proper procedures are not followed.
- A falling load may cause serious injury or death.
- See OSHA Rule 1926.1431(g)(1)(i)(A) and 1926.1501(g)(4)(iv)(B) for Personnel Hoisting by Crane or Derricks. A Crosby or McKissick Hook with a Positive Locked PL-N/O or S-4320 Latch may be used to lift personnel.
- Hook must always support the load. The load must never be supported by the latch.
- DO NOT use this latch in applications requiring non-sparking.
- Read and understand these instructions before using hook and latch.

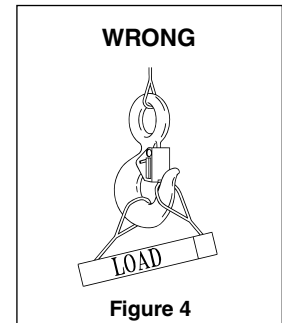
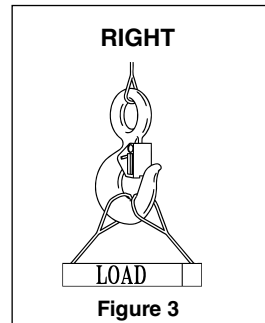
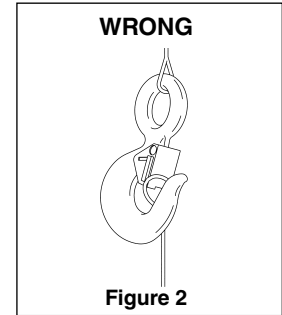
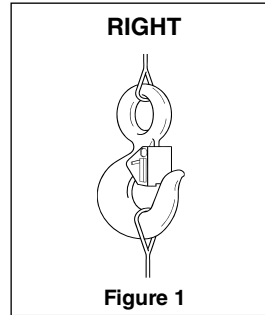

### IMPORTANT - Instructions for Assembling Model PL-N/O Latch on Crosby or McKissick Hooks

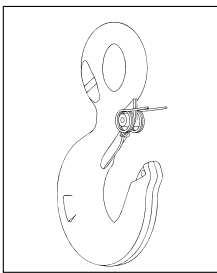

**Step 1**

1. Place hook in upright position. Position coils of spring over cam with legs of spring pointing toward tip of hook, and loop of spring positioned down and lying against the hook.

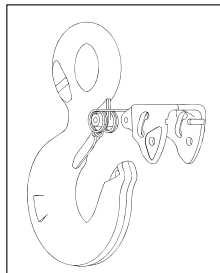

**Step 2**

2. Slip the latch over the spring until the two spring legs are positioned into the grooves located on the inside of the latch housing (legs of spring should fit between the gate and the housing).

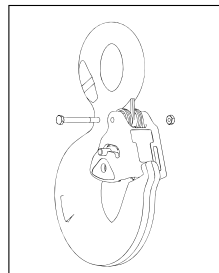

**Step 3 4, 5, & 6**

3. Slide latch housing up the spring legs until latch clears hook tip.
4. Resting latch on interlocking hook tip, line up holes in latch with hook cam.
5. Insert bolt through latch spring & cam.
6. Tighten self-locking nut on one end of bolt.

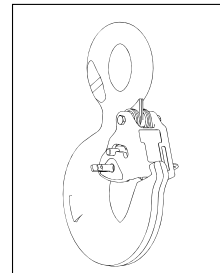

**Step 7, 8 - For Personnel Lifting**

7. Rigging should be resting in bowl of hook, with latch in closed position and gate locked.
8. Insert toggle lock pin through hole and depress spring until toggle clears hole on other side of latch.

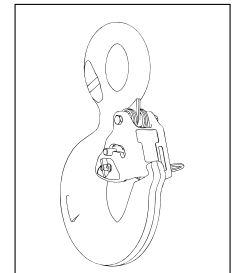

**Step 9 - For Personnel Lifting**

9. Rotate toggle 90 degrees to secure pin (ensure toggle is in closed position as shown).



# Crosby® ROV HOOKS

## WARNINGS & APPLICATION INSTRUCTIONS



**QUIC-CHECK®** Hoist hooks incorporate markings forged into the product which address two (2) **QUIC-CHECK®** features:



**Deformation Indicators** – Two strategically placed marks, one just below the shank or eye and the other on the hook tip, which allows for a **QUIC-CHECK®** measurement to determine if the throat opening has changed, thus indicating abuse or overload.

**To check**, use a measuring device (i.e., tape measure) to measure the distance between the marks. The marks should align to either an inch or half-inch increment on the measuring device. If the measurement does not meet criteria, the hook should be inspected further for possible damage.

**Angle Indicators** – Indicates the maximum included angle which is allowed between two (2) sling legs in the hook. These indicators also provide the opportunity to approximate other included angles between two sling legs.

### IMPORTANT SAFETY INFORMATION - READ & FOLLOW

- A visual periodic inspection for cracks, nicks, wear, gouges and deformation as part of a comprehensive documented inspection program, should be conducted by trained personnel in compliance with the schedule in ASME B30.10 and/or regulations governing your industry or jurisdiction.
- For ROV hooks used in frequent load cycles or pulsating loads, the ROV hook components (hoist hook, eye bolt and hexagon body) and their threads should be periodically inspected by Magnetic Particle or Dye Penetrant (Disassembly will be required).
- Disassemble the eye bolt and shank hook from hexagon body (sizes up to and including 31.5t WLL). This requires removing the 2 spiral pins and unscrewing the eye bolt and hoist hook.
- Always use new spiral pins when re-assembling the ROV Hook.
- After reassembly, Crosby recommends a proof test equal to 2 times the ROV hook's stated WLL.
- Never use a hoist hook whose throat opening has been increased, or whose tip has been bent more than 10 degrees out of plane from the hook body, or is in any other way distorted or bent. Note: A latch will not work properly on a hook with a bent or worn tip.
- Never use a hoist hook that is worn beyond the limits shown in Figure 1.
- Remove from service any hoist hook with a crack, nick or gouge. Hoist hooks with a nick or gouge shall be repaired

## ⚠ WARNING

- Loads may disengage from hook if proper procedures are not followed.
- A falling load may cause serious injury or death.
- Hook must always support the load. The load must never be supported by the latch.
- Read and understand these instructions before using hook and latch.

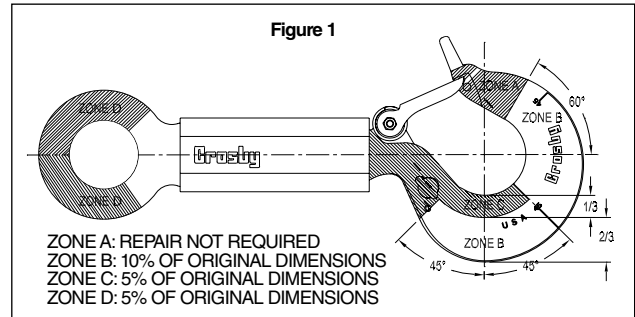

by grinding lengthwise, following the contour of the hook, provided that the reduced dimension is within the limits shown in Figure 1. Contact Crosby Engineering to evaluate any cracks.

- Never repair, alter, rework, or reshape an ROV hook by welding, heating, burning, or bending.
- Remove from service a hoist hook or eye bolt which has threads corroded more than 20% of the hexagon body engagement length.
- Never side load, back load, or tip load the hoist hook, eye bolt or hexagon body. (Side loading, back loading and tip loading are conditions that damage and reduce the capacity of the ROV hook). (See Figure 2.)
- The use of a latch may be mandatory by regulations or safety codes. Follow the regulations governing your industry or jurisdiction.

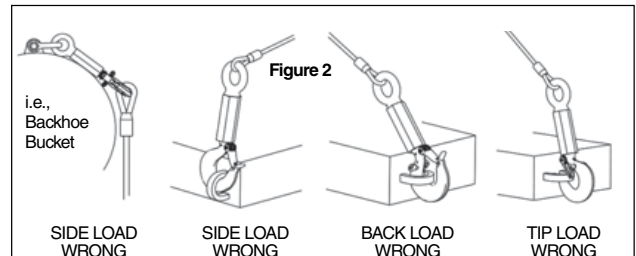

- Always make sure the hook supports the load. (See Figure 3 on page 156). The latch must never support the load (See Figure 4 on page 156).
- When multileg slings are placed in the base (bowl/saddle) of the hook, the maximum included angle between sling legs shall be 90 deg. The maximum sling leg angle with respect to the hook centerline for any rigging arrangement shall be 45 degrees. A collector ring, such as a link or shackle, should be used to maintain in-line load when more than two legs are placed in a hook or for angles greater than 45 degrees with respect to hook centerline. When more than two legs are placed in the hook bunching of the legs shall be avoided.
- See ASME B30.10 "Hooks" for additional information.
- Remove from service any eye bolt with a crack, nick or gouge. Eye bolt with a nick or gouge shall be repaired by grinding lengthwise, following the contour of the eye bolt, provided that the reduced dimension is no greater than 5% of original dimension. Contact Crosby Engineering to evaluate any cracks.

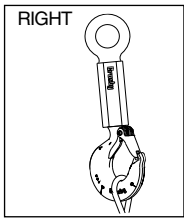

Figure 3

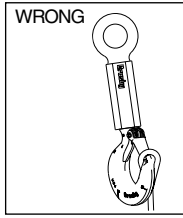

Figure 4

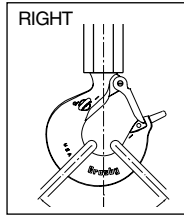

Figure 5

- Never use an eye bolt if eye or shank is bent or elongated.
- Remove from service the hexagon body if internal threads are corroded beyond 20% of the eye bolt or hoist hook shank's threaded engagement lengths.
- Hexagon body with nicks or gouges may be repaired by grinding lengthwise.
- Inspect the spiral pin holes on the hoist hook, hexagon body and eye bolt. At assembly, the spiral pin must engage with a press fit.

## Warning and Application Instructions for Crosby® Hook Latch

### Important Safety Information – Read & Follow

- Always inspect hook and latch before using.
- Never use a latch that is distorted or bent.
- Always make sure spring will force the latch against the tip of the hook.
- Always make sure hook supports the load. The latch must never support the load. (See Figures 1 & 2)
- When placing two (2) sling legs in hooks, make sure the angle between the legs is less than 90° and if the hook or load is tilted, nothing bears against the bottom of this latch. (See Figures 3 & 4)
- Latches are intended to retain loose sling or devices under slack conditions.
- Latches are not intended to be an anti-fouling device.

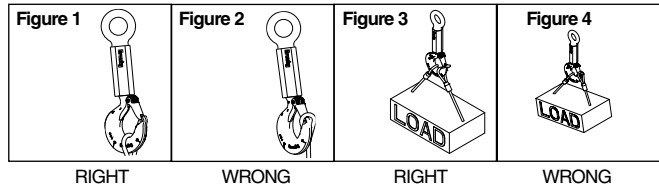

<b>⚠ WARNING</b>	
<ul style="list-style-type: none"> <li>• Loads may disengage from hook if proper procedures are not followed.</li> <li>• A falling load may cause serious injury or death.</li> <li>• See OSHA Rule 1926.550 (g)(4)(iv)(B) for personnel hoisting for cranes and derricks. Only a Crosby or McKissick hook with a PL Latch attached and secured with bolt, nut and cotter (or Crosby Toggle Pin) or a Crosby hook with a S-4320 Latch attached and secured with a cotter pin, or a Crosby SHUR-LOC® hook in the locked position may be used for any personnel hoisting. A hook with a Crosby SS-4055 latch attached shall NOT be used for personnel lifting.</li> <li>• Hook must always support the load. The load must never be supported by the latch.</li> <li>• Read and understand these instructions before using hook and latch.</li> </ul>	





# RIGGING ACCESSORIES

With Product Warnings and Application Information





# "There is No Equal"



The Market Leader: Yesterday Today and Tomorrow

## Rigging Accessories

### DESIGN

The theoretical reserve capability of turnbuckles should be five times the Working Load Limit (FF-T-791). Known as the DESIGN FACTOR, it is usually computed by dividing the catalog ultimate load by the Working Load Limit. The ultimate load is the average load or force at which the product fails or no longer supports the load. The Working Load Limit is the maximum mass or force which the product is authorized to support in general service. The design factor is generally expressed as a ratio, such as 5 to 1.

### THE COMPETITION

**Ask:** What is the design factor?

Most competitors do not provide turnbuckle assemblies that exceed Crosby's Working Load Limits with a design factor of 5 to 1.



All turnbuckles are designed with a design factor of at least 5 to 1. Crosby turnbuckles have the highest Working Load Limits in the industry. Crosby working load limits and design factors are based on extensive testing.

### HEAT TREATMENT

Heat treatment assures the uniformity of performance and maximizes the properties of the steel. This assures that each turnbuckle will meet its rated strength. The requirements of your job demand this reliability and consistency. All turnbuckle bodies should be normalized and end fittings should be normalized or quenched and tempered in order to assure uniformity. These heat treat processes develop a tough material that reduces the risk of a brittle, catastrophic failure, and assures the performance of the turnbuckle assembly.

### THE COMPETITION

**Ask:** Do they utilize the combination of heat treatment that assures the performance of the turnbuckle assembly?

Most normalize both the turnbuckle body and end fittings. Some provide turnbuckles in an "as forged" condition.



All turnbuckles are heat treated. Bodies are normalized, and end fittings are quenched and tempered or normalized. These heat treat processes provide a turnbuckle assembly that has superior impact and fatigue qualities and assures performance.



### GALVANIZE AND THREAD FORM

Galvanizing provides the best resistance to corrosion. Turnbuckle ends are the most highly stressed part of the assembly. This stress is at its peak at the root of the threaded shank. The turnbuckle ends should be threaded with a modified thread that minimizes the stress at the root of the thread.

### THE COMPETITION

**Ask:** Do they use the modified UNJ thread

Most galvanize their turnbuckles but do not utilize the modified thread.



All turnbuckles are available galvanized. Turnbuckle ends are threaded with a modified UNJ thread. This thread form, in conjunction with quench and tempering, gives Crosby turnbuckles their superior impact and fatigue performance.

### FULL LINE AND IDENTIFICATION

The proper application of turnbuckles requires that the correct type and size of turnbuckle be used. The turnbuckle size, the manufacturer's logo, and a product identification code should be clearly and boldly marked in the end fittings as well as in the turnbuckle body. Traceability of the material chemistry is essential for total confidence in the manufacturer of the product. Availability over the full range of sizes of hook, eye, and jaw type turnbuckle assemblies is essential for flexibility in the design of a total system

### THE COMPETITION

**Ask:** Do they have a traceability system?

**Ask:** Is the full range of type and size turnbuckles offered?

Most competitors do not have the full line that Crosby produces, or a traceability system.



Crosby forges its logo, sizes, and the Product Identification Code (PIC) into each component of its full line of hook, jaw, and eye type turnbuckles.

**Remember: "When buying Crosby, you're buying more than product, you're buying Quality."**

- **Charpy Impact Properties:** Crosby's quenched, tempered and normalized end fittings and normalized bodies have enhanced impact properties for greater toughness at all temperatures. If requested at the time of order, Crosby can provide Charpy impact properties.
- **Fatigue Properties:** Typical fatigue properties are available for selected sizes. Crosby turnbuckles are designed with quenched, tempered or normalized end fittings and modified UNJ threads for improved fatigue properties.
- **Typical Hardness Levels, Tensile Strengths and Ductility Properties:** These properties are available for all sizes.
- **Inspection:** If requested at the time of order, turnbuckles can be furnished proof tested or magnaflux inspected with certificates.
- **Full Line:** Turnbuckle assembly combinations include: Eye and Eye, Hook and Hook, Hook and Eye, Jaw and Jaw, Jaw and Eye.
- **Hot Dip Galvanize:** Turnbuckle components have a high quality "hot dip" galvanize finish. Self colored turnbuckle bodies are available upon request.
- **Jaw Ends:** Jaw ends are fitted with bolts and nuts (1/4" through 5/8"), or pins and cotters (3/4" through 2-3/4").
- **Turnbuckle Eyes:** Eyes are elongated by design, maximizing easy attachment in system and minimizing stress in the eye. For turnbuckle sizes 1/4" through 2-1/2", shackles one size smaller can be reeved through the eye.
- **Turnbuckle Hooks:** Crosby forges its turnbuckle hooks with a greater cross sectional area that results in a stronger hook with better fatigue properties.
- **Material Analysis:** Crosby can provide certified material (mill) analysis for each production lot, traceable by the Product Identification Code (PIC). Crosby, through its own laboratory, verifies the analysis of each heat of steel. Crosby purchases only special bar forging quality steel with specific cleanliness requirements and guaranteed hardenability.

### HG-223

#### **HOOK & HOOK**

*Meets the performance requirements of Federal Specifications FF-791b, Type 1, Form 1, Class 5, and ASTM F-1145, except for those provisions required of the contractor.*



### HG-225

#### **HOOK & EYE**

*Meets the performance requirements of Federal Specifications FF-791b, Type 1, Form 1, Class 6, and ASTM F-1145, except for those provisions required of the contractor.*



### HG-226

#### **EYE & EYE**

*Meets the performance requirements of Federal Specifications FF-791b, Type 1, Form 1, Class 4, and ASTM F-1145, except for those provisions required of the contractor.*



### HG-227

#### **JAW & EYE**

*Meets the performance requirements of Federal Specifications FF-791b, Type 1, Form 1, Class 8, and ASTM F-1145, except for those provisions required of the contractor.*



### HG-228

#### **JAW & JAW**

*Meets the performance requirements of Federal Specifications FF-791b, Type 1, Form 1, Class 7, and ASTM F-1145, except for those provisions required of the contractor.*



### HG-251

#### **STUB END**

*Meets the performance requirements of Federal Specifications FF-791b, Type 1, Form 1, Class 3, and ASTM F-1145, except for those provisions required of the contractor.*





**G-414**

G-414 meets the performance requirements of Federal Specification FF-T-276b Type III, except for those provisions required of the contractor. For additional information, see page 452.

- Available in Hot Dip galvanized or Stainless Steel (Type 304).
- Stainless steel recommended for more corrosive environments where greater protection is required.
- Greater protection against wear and deformation of the wire rope eye.
- Longer service life.

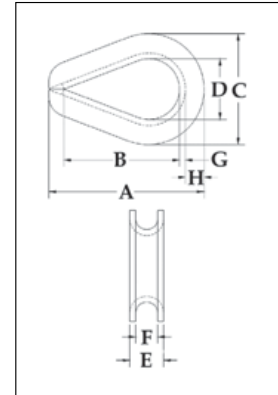

## Extra heavy Wire Rope Thimbles

Rope Dia.		Stock No.		Weight Per 100 (lb)	Dimensions (in)							
(in)	(mm)	G-414 Stock No	SS-414 Stainless		A	B	C	D	E	F	G	H
*1/4	6-7	1037639	1037960	7	2.19	1.62	1.50	.88	.41	.28	.06	.25
* 5/16	8	1037657	1037988	14	2.50	1.88	1.81	1.06	.50	.34	.08	.30
* 3/8	9-10	1037675	1038004	23	2.88	2.12	2.12	1.12	.63	.41	.11	.39
7/16	11-12	1037693	-	37	3.25	2.38	2.38	1.25	.72	.47	.12	.45
* 1/2 - 9/16	13-15	1037719	1038022	50	3.62	2.75	2.75	1.50	.89	.59	.15	.48
* 5/8	16	1037755	1038040	82	4.25	3.25	3.12	1.75	1.00	.66	.16	.53
* 3/4	18-20	1037773	1038068	157	5.00	3.75	3.81	2.00	1.22	.78	.22	.69
7/8	22	1037791	-	190	5.50	4.25	4.25	2.25	1.38	.94	.22	.78
1	24-26	1037817	-	280	6.12	4.50	4.75	2.50	1.56	1.06	.25	.88
1-1/8 - 1-1/4	28-32	1037835	-	-	7.00	5.12	5.88	2.88	1.88	1.31	.25	1.25
1-1/4 - 1-3/8	32-35	1037853	-	830	9.08	6.50	6.81	3.50	2.25	1.44	.37	1.29
1-3/8 - 1-1/2	35-38	1037871	-	1250	9.00	6.25	7.12	3.50	2.62	1.56	.50	1.31
1-5/8	40	1037899	-	-	11.25	8.00	8.12	4.00	3.00	1.72	.50	1.38
1-3/4	44	1037915	-	1860	12.19	9.00	8.50	4.50	3.06	1.84	.50	1.50
1-7/8 - 2	48-52	1037933	-	2780	15.12	12.00	10.38	6.00	3.38	2.09	.50	1.69
2-1/4	56	1037951	-	-	17.50	14.00	11.88	7.00	3.88	2.38	.62	1.82



**G-414 SL**

G-414 SL meets the performance requirements of Federal Specification FF-T-276b Type III, except for those provisions required of the contractor. For additional information, see page 452.

- Prevents the shackle from being removed and replaced in the field, which could compromise the certified integrity of the sling assembly.
- Available in Hot Dip galvanized. Crosby's shackle locking thimbles are galvanized after the welding of the wedge has been completed.
- Greater protection against wear and deformation of the wire rope eye.
- Longer service life.

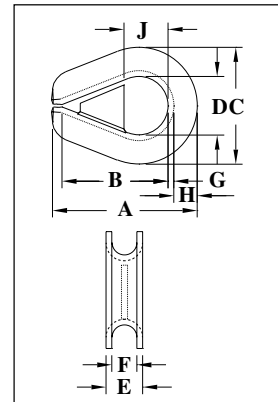

Scan our QR code with your smart device to visit the online flye .



## Extra Heavy Wire Rope Thimbles (Shackle-Loc)

Rope Dia.		Stock No.		Weight Per 100 (lb)	Dimensions (in)								
(in)	(mm)	G-414SL Stock No			A	B	C	D	E	F	G	H	J
3/8	9-10	1036800		24	2.88	2.12	2.12	1.12	.63	.41	.11	.39	.81
1/2 - 9/16	13-15	1036808		55	3.62	2.75	2.75	1.50	.89	.59	.15	.48	1.12
5/8	16	1036817		82	4.25	3.25	3.12	1.75	1.00	.66	.16	.53	1.25
3/4	18-20	1036826		161	5.00	3.75	3.81	2.00	1.22	.78	.22	.69	1.50
7/8	22	1036835		206	5.50	4.25	4.25	2.25	1.38	.94	.22	.78	1.63
1	24-26	1036844		300	6.12	4.50	4.75	2.50	1.56	1.06	.25	.88	1.88
1-1/8 - 1-1/4	28-32	1036853		425	7.00	5.12	5.88	2.88	1.88	1.31	.25	1.25	2.13
1-3/8 - 1-1/2	35-38	1036862		1317	9.00	6.25	7.12	3.50	2.62	1.56	.50	1.31	2.50



# Wire Rope Thimbles



**G-411**

- Hot Dip galvanized steel.
- The standard choice for light duty applications and loading conditions.

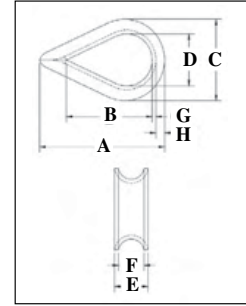

## Standard Wire Rope Thimbles

Rope Dia.		G-411 Stock No	Weight Per 100 (lb)	Dimensions (in)							
(in)	(mm)			A	B	C	D	E	F	G	H
1/8	3-4	1037256	3.50	1.94	1.31	1.06	.69	.25	.16	.05	.13
3/16	5	1037274	3.50	1.94	1.31	1.06	.69	.31	.22	.05	.13
1/4	6-7	1037292	3.50	1.94	1.31	1.06	.69	.38	.28	.05	.13
5/16	8	1037318	4.00	2.13	1.50	1.25	.81	.44	.34	.05	.13
3/8	9-10	1037336	6.70	2.38	1.63	1.47	.94	.53	.41	.06	.16
1/2	11-13	1037354	12.50	2.75	1.88	1.75	1.13	.69	.53	.08	.19
5/8	16	1037372	34.50	3.50	2.25	2.38	1.38	.91	.66	.13	.34
3/4	18-20	1037390	47.10	3.75	2.50	2.69	1.63	1.08	.78	.14	.34
7/8	22	1037416	84.60	5.00	3.50	3.19	1.88	1.27	.94	.16	.44
1	24-26	1037434	97.50	5.69	4.25	3.75	2.50	1.39	1.06	.16	.41
1-1/8 - 1-1/4	28-32	1037452	175.00	6.25	4.50	4.31	2.75	1.75	1.31	.22	.50

G-411 meets the performance requirements of Federal Specification FF- 276b Type II, except for those provisions required of the contractor. For additional information, see page 444.



**G-408**  
(Open Pattern)

- Hot Dip galvanized Steel.
- Recommended for light duty applications in which it is being assembled into another fitting (i.e., shackle or master link).

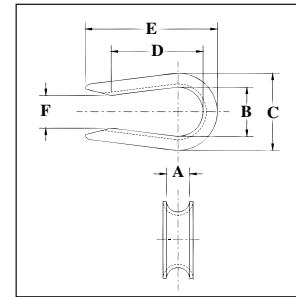

## Open Pattern Thimbles

Rope Dia.		G-408 Stock No	Weight Per 100 (lb)	Dimensions (in)					
(in)	(mm)			A	B	C	D	E	F
1/4	6-7	1037531	3.00	.28	.69	1.06	1.41	2.03	.38
5/16	8	1037559	3.80	.34	.81	1.25	1.53	2.16	.50
3/8	9-10	1037577	7.00	.44	.94	1.47	1.72	2.47	.62
1/2	11-13	1037595	12.50	.53	1.12	1.75	1.97	2.84	.75
5/8	16	1037611	25.00	.66	1.38	2.38	2.34	3.59	1.00



**S-412**

- Cast Ductile Iron.
- Fits pin for open wire rope socket, boom pendant clevis and wedge socket.

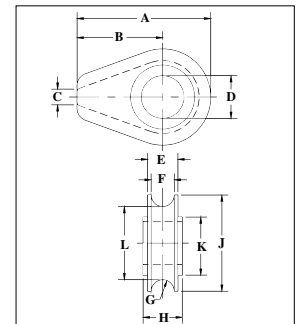

## Solid Wire Rope Thimbles

Rope Dia.		S-412 Stock No	Weight Per 100 (lb)	Dimensions (in)										
(in)	(mm)			A	B	C	D	E	F	G	H	J	K	L
1/2	13	1037121	.61	2.81	1.75	.25	1.06	.75	.56	.28	.88	2.13	1.63	1.56
5/8	16	1037149	2.21	4.69	3.00	.38	1.31	1.06	.81	.41	1.13	3.38	2.25	2.56
3/4	18-20	1037167	2.32	4.69	3.00	.38	1.50	1.06	.81	.41	1.38	3.38	2.25	2.56
7/8	22	1037185	5.45	6.06	3.81	.50	1.75	1.38	1.06	.53	1.63	4.50	3.25	3.44
1	24-26	1037201	5.25	6.06	3.81	.50	2.13	1.38	1.06	.53	1.81	4.50	3.25	3.44
1-1/8	28-30	1037229	9.29	7.25	4.56	.63	2.38	1.75	1.31	.66	2.06	5.38	3.88	4.06
1-1/4 - 1-3/8	32-35	1037247	9.81	7.25	4.56	.63	2.63	1.94	1.53	.78	2.31	5.38	3.88	4.13



**A-342**  
Alloy Master Links

- Alloy Steel — Quenched and Tempered.
- Individually Proof Tested to values shown, with certification
- Proof Tested with special fixtures sized to prevent localized point loading. See foot notes, and reference page 276.
- Forgings have a Product Identification Code (PIC) for material traceability, along with the size, the name Crosby and USA in raised lettering.
- Selected sizes designated with "W" in the size column have enlarged inside dimensions to allow additional room for sling hardware and crane hook.
- Crosby 7/8" to 2" 342 master links are type approved to DNV GL-ST-E271-2.7-1 Offshore Containers. These Crosby master links are 100% proof tested, MPI and impact tested. The tests are conducted by Crosby and 3.1 test certification is available upon request. Refer to page 164 for Crosby COLD TUFF® master links that meet the additional requirements of DNV rules for certification of lifting appliances - Loose Gear.
- Incorporates patented **QUIC-CHECK®** deformation indicators.
- Meets or exceeds all requirements of ASME B30.26 including identification, ductility, design factor, proof load and temperature requirements. Importantly, these links meet other critical performance requirements including fatigue life, impact properties and material traceability, not addressed by ASME B30.26.

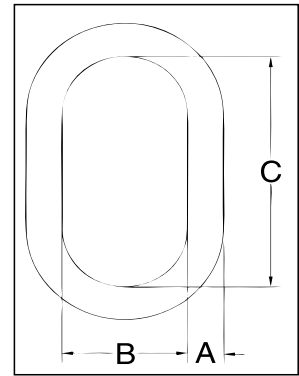

Load Rated

Fatigue Rated



**A-342 Alloy Master Links**

Size		A-342 Stock No	Weight Each (lb)	Working Load Limit (lb)*	Proof Load (lb)**	Dimensions (in)			
(in)	(mm)					A	B	C	Deformation Indicator
1/2W	13W	1014266	1.3	7400	17200	.62	2.80	5.00	3.50
5/8	16	1014280	1.5	9000	18000	.62	3.00	6.00	3.50
3/4W	19W	1014285	2.0	12300	28400	.73	3.20	6.00	4.00
7/8W	22W	3522213	3.3	15200	†38000	.88	3.75	6.38	4.50
1W	26W	3522214	6.1	26000	†65000	1.10	4.30	7.50	5.50
1-1/4W	32W	3522215	12.0	39100	†97750	1.33	5.50	9.50	7.00
1-1/2W	38W	3522216	18.6	61100	†152750	1.61	5.90	10.50	6.50
1-3/4	44	3522217	25.2	84900	†212250	1.75	6.00	12.00	7.50
2	51	3522218	37.0	102600	†256500	2.00	7.00	14.00	9.00
2-1/4	57	1014422	54.1	143100	289200	2.25	8.00	16.00	10.00
2-1/2	63	1014468	68.5	160000	320000	2.50	8.38	16.00	11.00
2-3/4	70	1014440	94.0	216900	433800	2.75	9.88	18.00	12.50
3	76	1014486	115	228000	456000	3.00	9.88	18.00	13.00
3-1/4	83	1014501	145	262200	524400	3.25	10.00	20.00	13.50
3-1/2	89	1014529	200	279000	558000	3.50	12.00	24.00	15.50
3-3/4	95	1015051	198	336000	672000	3.75	10.00	20.00	13.50
4	102	1015060	264	373000	746000	4.00	12.00	24.00	16.00
†† 4-1/4	†† 108	1015067	302	354000	708000	4.25	12.00	24.00	-
†† 4-1/2	†† 114	1015079	345	360000	720000	4.50	14.00	28.00	-
†† 4-3/4	†† 121	1015088	436	389000	778000	4.75	14.00	28.00	-
†† 5	†† 127	1015094	516	395000	790000	5.00	15.00	30.00	-

\*Ultimate Load is 5 times the Working Load Limit. Based on single leg sling (in-line load), or resultant load on multiple legs with an included angle less than or equal to 120 degrees. Applications with wire rope and synthetic sling generally require a design factor of 5. \*\*Proof Test Load equals or exceeds the requirement of ASTM A952(8.1) and ASME B30.9. †Offshore Container Master Links Proof Tested to 2.5 times the Working Load Limit with 70 percent fixtures. †† Welded Master Link.



For use with chain slings, refer to page 243 for sling ratings and page 240 for proper master link selection.

# Alloy Master Links with Engineered Flat



**A-345**  
Alloy Master  
Links

- Alloy Steel — Quenched and Tempered.
- Individually Proof Tested to values shown, with certification
- Proof Tested with 60% inside width special fixtures sized to prevent localized point loading per ASTM A952, reference page 276.
- Forgings have a Product Identification Code (PIC) for material traceability, along with the size, the name Crosby and USA in raised lettering.
- Selected sizes designated with “W” in the size column have enlarged inside dimensions to allow additional room for sling hardware and crane hook.
- Incorporates patented **QUIC-CHECK**® deformation indicators.
- Meets or exceeds all requirements of ASME B30.26 including identification, ductility, design factor, proof load and temperature requirements. Importantly, these links meet other critical performance requirements including fatigue life, impact properties and material traceability, not addressed by ASME B30.26.

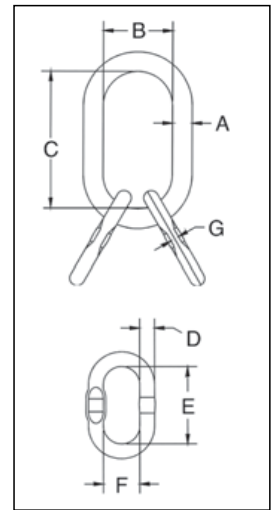

Rigging  
Accessories

**Load Rated**

**Fatigue Rated**



**MAXTOUGH**



## A-345 Master Link Assembly with Engineered Flat for use with S-1325A coupler link.

Size		A-345 Stock No.	Weight Each (lb)	Working Load Limit Based on 5:1 Design Factor (lb)*	Proof Load (lb)**	Dimensions (in)							Deformation Indicator
(in)	(mm)					A	B	C	D	E	F	G	
3/4W	19W	1014739	3.5	12300	28400	.73	3.20	6.00	.56	3.35	1.77	.30	4.00
7/8W	22W	1014742	4.8	15200	35200	.88	3.75	6.38	.56	3.35	1.77	.30	4.50
1W	26W	1014766	9.3	26000	60000	1.10	4.30	7.50	.75	3.94	2.36	.33	5.50
1-1/4W	32W	1014779	15.8	39100	90400	1.33	5.50	9.50	1.00	6.30	3.54	.51	7.00
1-1/2W	38W	1014807	34.1	61100	141200	1.61	5.90	10.50	1.25	7.09	3.94	.65	7.50
1-3/4	44	1014814	46.7	84900	212250	1.75	6.00	12.00	1.38	8.00	5.00	.73	7.50
2	51	1014832	67.2	102600	256500	2.00	7.00	14.00	1.50	9.00	5.75	-	9.00
2-1/2	64	1014855	206	160000	320000	2.50	8.38	16.00	2.50	16.00	8.38	-	11.00
2-3/4	70	1014864	282	216900	433800	2.75	9.88	18.00	2.75	18.00	9.88	-	12.50
4	102	1014999	667	373000	746000	4.00	12.00	24.00	3.50	24.00	12.00	-	15.50***

\* Ultimate Load is 5 times the Working Load Limit. The maximum individual sublink working load limit is 75% of the assembly working load limit except for 2-1/2" and 2-3/4", which are 100% of assembly working load limit. Applications with wire rope and synthetic sling generally require a design factor of 5. \*\*Proof Test Load equals or exceeds the requirement of ASTM A952(8.1) and ASME B30.9.



For use with chain slings, refer to page 244 for sling ratings and page 240 for proper master link selection.



## Welded Master Links with Engineered Flat



**A-344**  
Welded Master  
Links

Ultimate Load is 5 times the Working Load Limit. Applications with wire rope and synthetic sling generally require a design factor of 5. Based on single leg sling (in-line load), or resultant load on multiple legs with an included angle less than or equal to 120 degrees. \*\* Proof Test Load equals or exceeds the requirement of ASTM A952(8.1) and ASME B30.9. For use with chain slings, refer to page 240 for sling ratings and page 245 for proper master link selection.

- Alloy Steel - Quenched and Tempered.
- Individually Proof Tested to values shown, with certification
- Proof Tested with 60% inside width special fixtures sized to prevent localized point loading per ASME A-952 , reference page 276.
- Each link has a Product Identification Code (PIC) for material traceability, along with the size and the name Crosby® or “CG”.
- Large inside width and length to allow additional room for sling hardware and crane hook.
- Engineered Flat for use with S-1325A coupler link.
- Meets or exceeds all requirements of ASME B30.26 including identification, ductility, design factor, proof load and temperature requirements. Importantly, these links meet other critical performance requirements including fatigue life, impact properties and material traceability, not addressed by ASME B30.26.
- Master links are type approved to DNV Certification Notes 2.7-1- Offshore Containers. These Crosby master links are 100% proof tested, MPI and impact tested. The tests are conducted by Crosby and 3.1 test certification is available upon request. Refer to page 164 for Crosby COLD TUFF® master links that meet the additional requirements of DNV rules for certification of lifting appliances - Loose Gea .
- 7/16” through 1-7/32” have Engineered Flat.

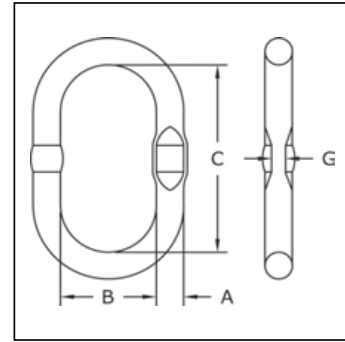

### A-344 Welded Master Links with Engineered Flat

Size		A-344 Stock No	Weight Each (lb)	Working Load Limit (lb)*	Proof Load (lb)**	Dimensions (in)				Engineered Flat Size for S-1325A (in)
(in)	(mm)					A	B	C	G	
7/16	12	1256862	0.66	3500	8800	.47	2.36	4.72	.24	1/4
1/2	13	1256932	0.79	5500	14000	.51	2.36	4.72	.26	1/4
11/16	17	1257002	1.85	9000	22700	.67	3.54	6.30	.33	3/8
3/4	19	1257072	2.36	14700	36800	.75	3.54	6.30	.33	3/8
7/8	22	1257212	3.55	18700	46800	.87	3.94	7.10	.41	1/2
1	25	1257282	5.22	25300	63400	.98	4.53	8.10	.53	1/2
1-1/8	28	1257382	8.33	28600	71700	1.10	5.71	10.83	.53	1/2
1-7/32	31	1257422	10.3	37400	93700	1.22	5.71	10.83	.61	5/8
1-7/16	36	1257492	15.1	52900	132200	1.42	6.10	11.20	—	—
1-9/16	40	1257532	19.6	61900	154900	1.57	6.30	11.80	—	—
1-3/4	45	1257562	28.1	84400	211100	1.77	7.10	13.40	—	—
2	51	1257632	38.1	99200	248000	2.00	8.50	15.30	—	—

\*Ultimate Load is 5 times the Working Load Limit. Applications with wire rope and synthetic sling generally require a design factor of 5. Based on single leg sling (in-line load), or resultant load on multiple legs with an included angle less than or equal to 120 degrees. \*\*Proof Test Load equals or exceeds the requirement of ASTM A952(8.1) and ASME B30.9.



For use with chain slings, refer to page 245 for sling ratings and page 240 for proper master link selection.

# Welded Master Links with Engineered Flat



**A-347  
Welded Master  
Links**

Ultimate Load is 5 times the Working Load Limit. Applications with wire rope and synthetic sling generally require a design factor of 5. Based on single leg sling (in-line load), or resultant load on multiple legs with an included angle less than or equal to 120 degrees. \*\* Proof Test Load equals or exceeds the requirement of ASTM A952(8.1) and ASME B30.9. For use with chain slings, refer to page 240 for sling ratings and page 245 for proper master link selection.

- Alloy Steel — Quenched and Tempered.
- Individually Proof Tested to values shown, with certification
- Proof Tested with 60% inside width special fixtures sized to prevent localized point loading per ASME A-952 , reference page 276.
- Forgings have a Product Identification Code (PIC) for material traceability, along with the size, the name Crosby and USA in raised lettering.
- Selected sizes designated with "W" in the size column have enlarged inside dimensions to allow additional room for sling hardware and crane hook.
- Crosby 1 1/4" to 2" 344/347 master links are type approved to DNV Certification Notes 2.7-1- Offshore Containers. These Crosby master links are 100% proof tested, MPI and impact tested. The tests are conducted by Crosby and 3.1 test certification is available upon request. Refer to page 164 for Crosby COLD TUFF® master links that meet the additional requirements of DNV rules for certification of lifting appliances - Loose Gear.
- Engineered Flat for use with S-1325A coupler link.
- Meets or exceeds all requirements of ASME B30.26 including identification, ductility, design factor, proof load and temperature requirements. Importantly, these links meet other critical performance requirements including fatigue life, impact properties and material traceability, not addressed by ASME B30.26.

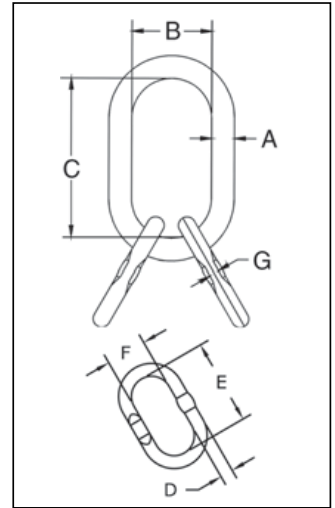

Rigging  
Accessories

## A-347 Welded Master Link Assembly with Engineered Flat

Size		A-347 Stock No	Weight Each (lb)	Working Load Limit (lb)*	Proof Load (lb)**	Dimensions (in)							Engineered Flat Size for S-1325A (in)
(in)	(mm)					A	B	C	D	E	F	G	
1/2	13/12	1257692	1.80	5300	13200	.51	2.36	4.72	.47	3.35	1.77	.24	-
11/16	17/13	1257762	3.40	9000	22700	.67	3.54	6.30	.51	4.72	2.36	.26	1/4
3/4	19/13	1257832	4.00	9300	23400	.75	3.54	6.30	.51	4.72	2.36	.26	1/4
7/8	22/17	1257972	7.20	14700	36800	.87	3.94	7.10	.67	6.30	3.54	.33	5/16
1-1/8	28/22	1258142	15.4	31900	79800	1.10	5.71	10.83	.87	7.10	3.94	.41	3/8
1-7/32	31/25	1258182	20.8	37500	93700	1.22	5.71	10.83	.98	8.10	4.53	.53	1/2
1-9/16	40/31	1258332	40.5	61900	154900	1.57	6.30	11.80	1.22	10.63	5.50	-	-
1-3/4	45/36	1258402	58.2	84400	211100	1.77	7.10	13.40	1.42	11.20	6.10	-	-
2	51/45	1258462	95.0	99200	248000	2.00	7.50	13.80	1.80	13.40	7.10	-	-

\*Ultimate Load is 5 times the Working Load Limit. Applications with wire rope and synthetic sling generally require a design factor of 5. Based on single leg sling (in-line load), or resultant load on multiple legs with an included angle less than or equal to 120 degrees.\*\*Proof Test Load equals or exceeds the requirement of ASTM A952(8.1) and ASME B30.9.



For use with chain slings, refer to page 246 for sling ratings and page 240 for proper master link selection.



**A-342CT**  
Master Links

- Alloy Steel - Quenched and Tempered
- Individually proof tested at 2 times Working Load Limit with certification
- Finish is Inorganic Zinc Primer.
- Certified to meet charpy impact testing of 31 ft-lbs. min. avg. at -4° .
- Individually serialized and all certification shipped with each link
- COLD TUFF® master links are suitable for use at -50° F.
- Type Approval and certification in accordance with DNV 2.7-1 O fshore Containers, DNV-OS-E101, and Rules for Certification of Lifting Appliances, and are produced in accordance with DNV MSA requirements, including required documents.
- Refer to page 88 for COLD TUFF® Shackles.
- Meets or exceeds all requirements of ASME B30.26 including identification, ductility, design factor, proof load and temperature requirements. Importantly, these fittings meet other critical performance requirements including fatigue life, impact properties and material traceability, not addressed by ASME B30.26.

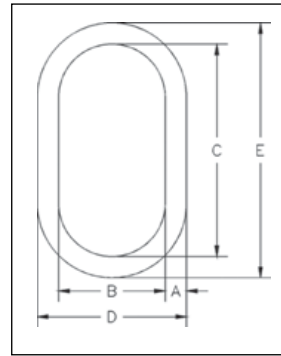

**A-342CT Master Links**

Size (in)	A-342CT Stock No.	Working Load Limit (lb)*	Weight Each (lb)	Dimensions (in)					Deformation Indicator
				A	B	C	D	E	
7/8W	1261392	15200	3.3	0.88	3.75	6.38	5.51	8.14	4.50
1-1/4W	1261407	39100	12.0	1.33	5.50	9.50	8.16	12.16	7.00
1-1/2W	1261418	61100	18.6	1.61	5.90	10.50	9.12	13.72	7.50
1-3/4	1261423	62520	25.2	1.75	6.00	12.00	9.50	15.50	7.50
2	1261433	97680	37.0	2.00	7.00	14.00	11.00	18.00	9.00

\*Minimum Ultimate Load is 5 times the Working Load Limit.



**A-345CT**  
Master Links  
Assembly

- Alloy Steel - Quenched and Tempered
- Individually proof tested at 2 times Working Load Limit with certification
- Finish is Inorganic Zinc Primer.
- Certified to meet charpy impact testing of 31 ft-lbs. min. avg. at -4° .
- COLD TUFF® master links are suitable for use at -50° F.
- Type Approval and certification in accordance with DNV 2.7-1 O fshore Containers, DNV-OS-E101, and Rules for Certification of Lifting Appliances, and are produced in accordance with DNV MSA requirements, including required documents.
- Refer to page 88 for COLD TUFF® Shackles.
- Meets or exceeds all requirements of ASME B30.26 including identification, ductility, design factor, proof load and temperature requirements. Importantly, these fittings meet other critical performance requirements including fatigue life, impact properties and material traceability, not addressed by ASME B30.26.

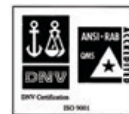
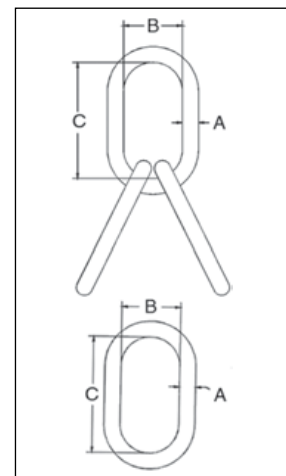

**A-345CT Master Link Assembly**

Size (in)	A-345CT Stock No.	Working Load Limit (lb)*	Weight Each (lb)	Dimensions (in)		
				A	B	C
1-1/4	1261609	35160	30.0	1.25	4.38	8.75
1-1/2	1261620	47880	51.0	1.50	5.25	10.50
1-3/4	1261631	62520	78.0	1.75	6.00	12.00
2	1261642	97680	123.0	2.00	7.00	14.00

\*Minimum Ultimate Load is 5 times the Working Load Limit.



# End Links and Weldless Rings



**G-340 / S-340**  
Weldless End Link

- Forged carbon steel - Quenched and Tempered
- Self Colored or Hot Dip galvanized.

G-340 from 5/8" thru 7/8" meet the performance requirements of Federal Specification RR-C-271F, Type XV, except for those provisions required of the contractor. For additional information, see page 452.

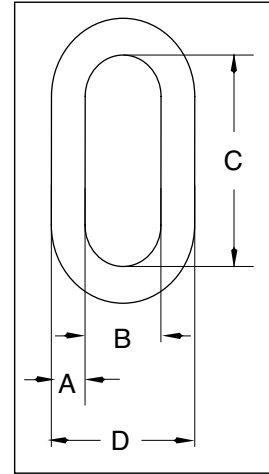

## G-340/S-340 Weldless End Links

Size (A) (in)	Stock No.		Working Load Limit (lb)*	Weight Each (lb)	Dimensions (in)			
	G-340 Galv.	S-340 S.C.			A	B	C	D
5/16	1014057	1014066	2500	.15	.31	.50	1.75	1.18
3/8	1014075	1014084	3800	.22	.38	.56	1.88	1.38
1/2	1014093	1014100	6500	.49	.50	.75	2.38	1.81
5/8	1014119	1014128	9300	.97	.63	1.00	3.25	2.32
3/4	1014137	1014146	14000	1.51	.75	1.13	3.50	2.68
7/8	1014155	1014164	12000	2.59	.88	2.00	5.13	3.75
1	1014173	1014182	15200	3.95	1	2.25	5.75	4.25
1-1/4	1014191	1014208	26400	7.30	1.25	2.50	7.00	5.00
1-3/8	1014217	1014226	30000	10.38	1.38	2.75	7.75	5.50

\*Ultimate Load is 5 times the Working Load Limit. Based on single leg sling (in-line load), or resultant load on multiple legs with an included angle less than or equal to 120°.

Rigging Accessories



**S-643**  
Weldless Rings

- Forged carbon steel - Quenched and Tempered.
- Self Colored

Weldless Rings meet the performance requirements of Federal Specification RR-C-271F Type VI, except for those provisions required of the contractor. For additional information, see page 452.

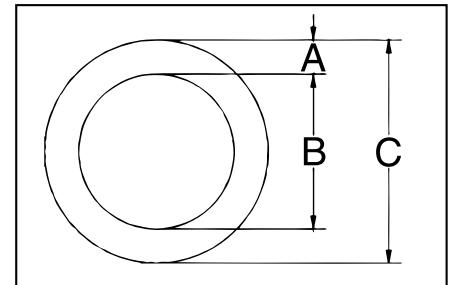

## S-643 Weldless Rings

Size (in)	S-643 Stock No	Working Load Limit Single Pull (lb)*	Weight Each (lb)	Dimensions (in)		
				A	B	C
7/8 x 4	1013780	7200	2.72	.88	4.00	5.75
7/8 x 5-1/2	1013806	5600	3.47	.88	5.50	7.25
1 x 4	1013824	10800	3.69	1.00	4.00	6.00
1-1/8 x 6	1013842	10400	6.60	1.13	6.00	8.25
1-1/4 x 5	1013860	17000	6.82	1.25	5.00	7.50
1-3/8 x 6	1013888	19000	10.12	1.38	6.00	8.75

\*Ultimate Load is 6 times the Working Load Limit.



**A-341**  
Alloy Pear Shaped Links

- Alloy Steel - Quenched and Tempered
- Individually Proof Tested at 2 times Working Load Limit with certification.
- Proof Test certification shipped with each link.
- Sizes 1/2", 5/8", 3/4", 7/8", 1", 1-1/4", and 1-3/8 are forged.

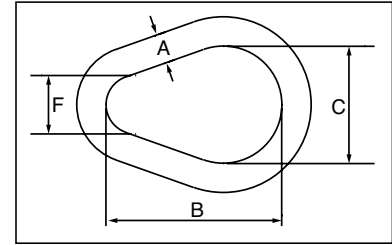

### A-341 Alloy Pear Shaped Links

Size (A) (in)	A-341 Stock No	Working Load Limit		Weight Each (lb)	Dimensions (in)		
		(lb)*	(t)		B	C	F
1/2	1013575	7000	3.15	.55	3.00	2.00	1.00
5/8	1013584	9000	4.09	1.10	3.75	2.50	1.25
3/4	1013595	12300	5.59	1.76	4.50	3.00	1.50
7/8	1013604	15000	6.81	2.82	5.25	3.50	1.75
1	1013613	24360	11.0	4.22	6.00	4.00	2.00
†† 1 1/8	1013622	30600	13.9	6.25	6.50	4.50	2.25
1 1/4	1013631	36000	16.4	8.25	7.75	5.00	2.50
1 3/8	1013640	43000	19.5	11.25	8.25	5.50	2.75
†† 1 1/2	1013649	54300	24.7	14.25	9.00	6.00	3.00
†† 1 5/8	1013658	62600	28.4	18.50	9.75	6.50	3.25
†† 1 3/4	1013667	84900	38.6	22.50	10.50	7.00	3.50
†† 1 7/8	1013676	95800	43.5	29.00	11.25	7.50	3.75
†† 2	1013685	102600	46.6	34.00	12.00	8.00	4.00
†† 2 1/4	1013694	143100	65.0	48.00	13.50	9.00	4.50
†† 2 1/2	1013703	147300	66.9	66.00	15.00	10.00	5.00
†† 2 3/4	1013712	216900	98.6	88.00	16.50	11.00	5.50
†† 3	1013721	228000	103	114.00	18.00	12.00	6.00
†† 3 1/4	1013730	262200	119	146.00	19.50	13.00	6.50
†† 3 1/2	1013739	279000	126	181.00	21.00	14.00	7.00
†† 4	1013748	373000	169	271.00	24.00	16.00	8.00

\*Based on single leg sling (in-line load), or resultant load on multiple legs with an included angle less than or equal to 120°. Minimum Ultimate load is 5 times the Working Load Limit. †† Welded Link.



**G-341 / S-341**  
Weldless Sling Link

- Forged carbon steel - Quenched and Tempered.
- Self Colored or Hot Dip galvanized.

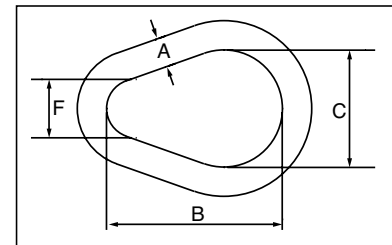

### G-341 / S-341 Weldless Sling Links

Size (A) (in)	Stock No.		Working Load Limit Single Pull (lb)*	Weight Each (lb)	Dimensions (in)		
	G-341 Galv.	S-341 S.C.			B	C	F
3/8	1013897	1013904	1800	.23	2.25	1.50	.75
1/2	1013913	1013922	2900	.55	3.00	2.00	1.00
5/8	1013931	1013940	4200	1.06	3.75	2.50	1.25
3/4	1013959	1013968	6000	1.88	4.50	3.00	1.50
7/8	1013977	1013986	8300	2.75	5.25	3.50	1.75
1	1013995	1014002	10800	4.35	6.00	4.00	2.00
1 1/4	1014011	1014020	16750	7.60	7.75	5.00	2.50
1 3/8	1014039	1014048	20500	11.30	8.25	5.50	2.75

\*Ultimate Load is 6 times the Working Load Limit. Based on single leg sling (in-line load), or resultant load on multiple legs with an included angle less than or equal to 120°.

# Forged Eye Bolts



**G-291**  
Regular Nut  
Eye Bolt

- Forged Steel - Quenched and Tempered.
- Fatigue rated at 1-1/2 times the Working Load Limit at 20,000 cycles.
- All Bolts Hot Dip galvanized after threading (UNC).
- Furnished with standard Hot Dip galvanized hex nuts.
- Recommended for in-line pull.
- Meets or exceeds all requirements of ASME B30.26 including identification, ductility, design factor, proof load and temperature requirements. Importantly, these bolts meet other critical performance requirements including fatigue life, impact properties and material traceability, not addressed by ASME B30.26.

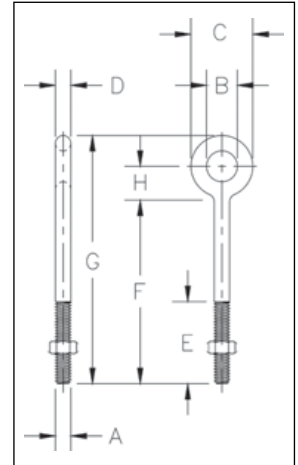

**Fatigue Rated**

**SEE APPLICATION AND WARNING INFORMATION**  
On Pages 200-201  
Para Español: [www.thecrosbygroup.com](http://www.thecrosbygroup.com)

Rigging  
Accessories

## G-291 Regular Nut Eye Bolts

Shank Dia. & Length (in)	G-291 Stock No.	Working Load Limit (lb)*	Weight Per 100 (lb)	Dimensions (in)							
				A	B	C	D	E	F	G	H
3/8 x 4-1/2	1043338	1550	29.50	.38	.75	1.50	.38	2.50	4.50	6.12	.88
1/2 x 3-1/4	1043374	2600	50.30	.50	1.00	2.00	.50	1.50	3.25	5.38	1.12
1/2 x 6	1043392	2600	66.10	.50	1.00	2.00	.50	3.00	6.00	8.12	1.12
1/2 x 8	1043418	2600	82.00	.50	1.00	2.00	.50	3.00	8.00	10.12	1.12
1/2 x 10	1043436	2600	88.00	.50	1.00	2.00	.50	3.00	10.00	12.12	1.12
1/2 x 12	1043454	2600	114.20	.50	1.00	2.00	.50	3.00	12.00	14.12	1.12
5/8 x 4	1043472	5200	103.10	.62	1.25	2.50	.62	2.00	4.00	6.69	1.44
5/8 x 6	1043490	5200	118.20	.62	1.25	2.50	.62	3.00	6.00	8.69	1.44
5/8 x 8	1043515	5200	135.10	.62	1.25	2.50	.62	3.00	8.00	10.69	1.44
5/8 x 10	1043533	5200	153.60	.62	1.25	2.50	.62	3.00	10.00	12.69	1.44
5/8 x 12	1043551	5200	167.10	.62	1.25	2.50	.62	4.00	12.00	14.69	1.44
3/4 x 4-1/2	1043579	7200	168.60	.75	1.50	3.00	.75	2.00	4.50	7.69	1.69
3/4 x 6	1043597	7200	184.50	.75	1.50	3.00	.75	3.00	6.00	9.19	1.69
3/4 x 8	1043613	7200	207.90	.75	1.50	3.00	.75	3.00	8.00	11.19	1.69
3/4 x 10	1043631	7200	235.00	.75	1.50	3.00	.75	3.00	10.00	13.19	1.69
3/4 x 12	1043659	7200	257.50	.75	1.50	3.00	.75	4.00	12.00	15.19	1.69
3/4 x 15	1043677	7200	298.00	.75	1.50	3.00	.75	5.00	15.00	18.19	1.69
7/8 x 5	1043695	10600	270.00	.88	1.75	3.50	.88	2.50	5.00	8.75	2.00
7/8 x 8	1043711	10600	308.00	.88	1.75	3.50	.88	4.00	8.00	11.75	2.00
7/8 x 12	1043739	10600	400.00	.88	1.75	3.50	.88	4.00	12.00	15.75	2.00
1 x 6	1043757	13300	421.00	1.00	2.00	4.00	1.00	3.00	6.00	10.31	2.31
1 x 9	1043775	13300	468.50	1.00	2.00	4.00	1.00	4.00	9.00	13.31	2.31
1 x 12	1043793	13300	540.00	1.00	2.00	4.00	1.00	4.00	12.00	16.31	2.31
1 x 18	1043819	13300	650.00	1.00	2.00	4.00	1.00	7.00	18.00	22.31	2.31
1-1/4 x 8	1043837	21000	750.00	1.25	2.50	5.00	1.25	4.00	8.00	13.38	2.88
1-1/4 x 12	1043855	21000	900.00	1.25	2.50	5.00	1.25	4.00	12.00	17.38	2.88
1-1/4 x 20	1043873	21000	1210.00	1.25	2.50	5.00	1.25	6.00	20.00	25.38	2.88

\*Ultimate Load is 5 times the Working Load Limit. Working Load Limit shown is for in-line pull. Maximum Proof Load is 2 times the Working Load Limit.





**G-277**  
Shoulder Nut  
Eye Bolts

- Forged Steel - Quenched and Tempered.
- Fatigue rated at 1-1/2 times the Working Load Limit at 20,000 cycles.
- Working Load Limits shown are for in-line pull. For angle loading, see page 200.
- Meets or exceeds all requirements of ASME B30.26 including identification, ductility, design factor, proof load and temperature requirements. Importantly, these bolts meet other critical performance requirements including fatigue life, impact properties and material traceability, not addressed by ASME B30.26.
- All Bolts Hot Dip galvanized after threading (UNC).
- Furnished with standard Hot Dip galvanized, heavy hex nuts.

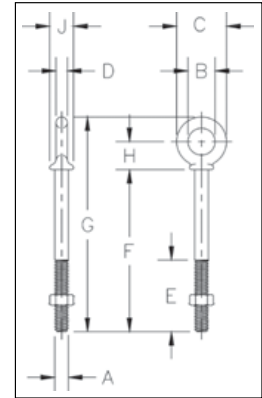

*Fatigue Rated*

**SEE APPLICATION AND WARNING INFORMATION**  
On Pages 200-201  
Para Español: [www.thecrosbygroup.com](http://www.thecrosbygroup.com)

**G-277 Shoulder Nut Eye Bolts**

Shank Diameter & Length (in)	G-277 Stock No.	Working Load Limit (lb)*	Weight Per 100 (lb)	Dimensions (in)									
				A	B	C	D	E	F	G	H	J	
5/16 x 2-1/4	1045050	1200	12.50	.31	.62	1.12	.25	1.50	2.25	3.50	.69	.56	
5/16 x 4-1/4	1045078	1200	18.80	.31	.62	1.12	.25	2.50	4.25	5.50	.69	.56	
3/8 x 2-1/2	1045096	1550	21.40	.38	.75	1.38	.31	1.50	2.50	3.97	.78	.66	
3/8 x 4-1/2	1045112	1550	25.30	.38	.75	1.38	.31	2.50	4.50	5.97	.78	.66	
1/2 x 3-1/4	1045130	2600	42.60	.50	1.00	1.75	.38	1.50	3.25	5.12	1.00	.91	
1/2 x 6	1045158	2600	56.80	.50	1.00	1.75	.38	3.00	6.00	7.88	1.00	.91	
5/8 x 4	1045176	5200	68.60	.62	1.25	2.25	.50	2.00	4.00	6.44	1.31	1.12	
5/8 x 6	1045194	5200	102.40	.62	1.25	2.25	.50	3.00	6.00	8.44	1.31	1.12	
3/4 x 4-1/2	1045210	7200	144.50	.75	1.50	2.75	.62	2.00	4.50	7.44	1.56	1.38	
3/4 x 6	1045238	7200	167.50	.75	1.50	2.75	.62	3.00	6.00	8.94	1.56	1.38	
7/8 x 5	1045256	10600	225.00	.88	1.75	3.25	.75	2.50	5.00	8.46	1.84	1.56	
1 x 6	1045292	13300	366.30	1.00	2.00	3.75	.88	3.00	6.00	9.97	2.09	1.81	
1 x 9	1045318	13300	422.50	1.00	2.00	3.75	.88	4.00	9.00	12.97	2.09	1.81	
1-1/4 x 8	1045336	21000	650.00	1.25	2.50	4.50	1.00	4.00	8.00	12.72	2.47	2.28	
1-1/4 x 12	1045354	21000	795.00	1.25	2.50	4.50	1.00	4.00	12.00	16.72	2.47	2.28	
1-1/2 x 15	1045372	24000	1425.00	1.50	3.00	5.50	1.25	6.00	15.00	20.75	3.00	2.75	

\*Ultimate Load is 5 times the Working Load Limit. Maximum Proof Load is 2 times the Working Load Limit.

# Forged Machinery Eye Bolts



**S-279 / M-279**  
Shoulder Type  
Machinery Eye Bolts

- Forged Steel - Quenched & Tempered.
- Working Load Limits shown are for in-line pull. For angle loading, see page 200.
- Fatigue rated at 1-1/2 times the Working Load Limit at 20,000 cycles.
- Recommended for in-line pull.
- S-279 threaded UNC.
- M-279 metric threaded.
- Meets or exceeds all requirements of ASME B30.26 including identification, ductility, design factor, proof load and temperature requirements. Importantly, these bolts meet other critical performance requirements including fatigue life, impact properties and material traceability, not addressed by ASME B30.26.

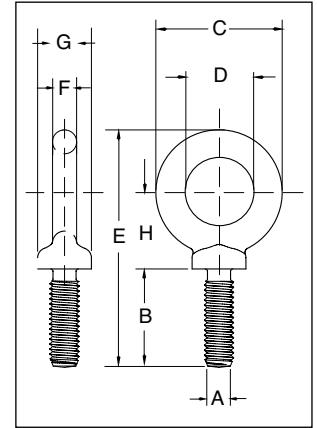

**Fatigue Rated**



## S-279 UNC Shoulder Type Machinery Eye Bolts

Size (in)	S-279 Stock No.	Working Load Limit (lb)*	Weight Per 100 (lb)	Dimensions (in)							
				A** Thread	B	C	D	E	F	G	H
1/4 x 1	9900182	650	5.00	1/4 - 20	1.02	1.13	.75	2.29	.19	.53	.77
5/16 x 1-1/8	9900191	1200	9.00	5/16 - 18	1.15	1.38	.88	2.74	.25	.59	.95
3/8 x 1-1/4	9900208	1550	15.00	3/8 - 16	1.27	1.62	1.00	3.07	.31	.69	1.05
1/2 x 1-1/2	9900217	2600	28.00	1/2 - 13	1.53	1.95	1.19	3.70	.38	.91	1.27
5/8 x 1-3/4	9900226	5200	55.00	5/8 - 11	1.79	2.38	1.38	4.45	.50	1.13	1.53
3/4 x 2	9900235	7200	96.00	3/4 - 10	2.05	2.76	1.50	5.07	.63	1.38	1.71
7/8 x 2-1/4	9900244	10600	154.00	7/8 - 9	2.31	3.25	1.75	5.87	.75	1.56	2.00
1 x 2-1/2	9900253	13300	238.00	1 - 8	2.57	3.76	2.00	6.66	.88	1.81	2.30
1-1/8 x 2-3/4	9900257	15000	320.00	1-1/8 - 7	2.75	4.19	2.25	7.20	.97	2.06	2.35
1-1/4 x 3	9900262	21000	399.00	1-1/4 - 7	3.09	4.50	2.50	7.95	1.00	2.28	2.73
1-1/2 x 3-1/2	9900271	24000	720.00	1-1/2 - 6	3.60	5.50	3.00	9.49	1.25	2.75	3.28
1-3/4 x 3-3/4	9900280	34000	1040.00	1-3/4 - 5	3.75	6.26	3.50	10.48	1.38	3.00	3.60
2 x 4	9900289	42000	1880.00	2 - 4-1/2	4.00	7.62	4.00	12.31	1.81	3.38	4.50
2-1/2 x 5	9900298	65000	3250.00	2-1/2 - 4	5.00	8.76	4.50	14.88	2.12	4.25	5.50

\*Ultimate Load is 5 times the Working Load Limit. Maximum Proof Load is 2 times the Working Load Limit. \*\* All bolts threaded UNC.



## M-279 Metric

Size (mm)	M-279 Stock No.	Working Load Limit (kg)*	Weight Each (kg)	Dimensions (mm)							
				A** Thread	B	C	D	E	F	G	H
M6 x 13	1045753	200	.03	M6 x 10	13.0	28.7	19.1	47.0	4.9	13.5	19.6
M8 x 13	1045789	400	.05	M8 x 125	13.0	35.1	22.4	54.6	6.4	15.0	24.1
M10 x 17	1045833	640	.07	M10 x 1.5	17.0	41.1	25.4	64.3	7.9	17.5	26.5
M12 x 20.5	1045869	1000	.11	M12 x 1.75	20.5	49.5	30.2	77.7	9.7	23.1	32.8
M16 x 27	1045913	1800	.25	M16 x 2.0	27.0	60.5	35.1	96.0	12.7	28.7	38.9
M20 x 30	1045995	2500	.42	M20 x 2.5	30.0	70.0	38.1	108	16.0	35.1	43.4
M24 x 36	1046029	4000	1.05	M24 x 3.0	36.0	95.5	51.0	142	22.4	46.0	58.4
M27 x 69.8	1046038	5000	1.42	M27 x 3.0	69.8	107	57.1	183	24.6	52.3	59.7
M30 x 45	1046075	6000	1.77	M30 x 3.5	45.0	114	63.5	171	25.4	58.0	69.3
M36 x 54	1046109	8500	3.12	M36 x 4.0	54.0	140	76.0	207	31.8	70.0	83.3
M42 x 95.2	1046118	14000	4.58	M42 x 4.5	95.2	159	88.9	266	35.0	76.2	91.4
M48 x 102	1046127	17300	8.71	M48 x 5.0	102	194	101	313	46.0	85.9	114
M64 x 127	1046136	29500	14.74	M64 x 6.0	127	223	114	378	53.8	108	140

\*Ultimate Load is 5 times the Working Load Limit. Maximum Proof Load is 2 times the Working Load Limit. \*\* On Request: Special threading or as forged bolts for customer conversion.



**S-293**  
Rivet Eye Bolt

- Forged steel - Quenched and Tempered.



**S-293 Rivet Eye Bolts**

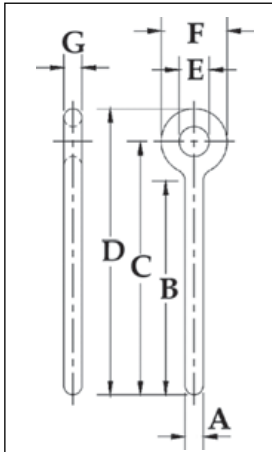

Shank Dia. & Length (in)	S-293 Stock No.	Weight Per 100 (lb)	Dimensions (in)						
			A	B	C	D	E	F	G
3/8 x 2-1/2	1043962	25.00	.38	2.50	3.38	4.13	.75	1.50	.38
3/8 x 4-1/2	1043980	27.60	.38	4.50	5.38	6.13	.75	1.50	.38
1/2 x 3-1/4	1044024	43.80	.50	3.25	4.38	5.38	1.00	2.00	.50
1/2 x 6	1044042	62.50	.50	6.00	7.13	8.13	1.00	2.00	.50
5/8 x 4	1044060	93.80	.62	4.00	5.50	6.75	1.25	2.50	.62
5/8 x 6	1044088	113.00	.62	6.00	7.50	8.75	1.25	2.50	.62
3/4 x 4-1/2	1044104	143.80	.75	4.50	6.25	7.75	1.50	3.00	.75
3/4 x 6	1044122	162.50	.75	6.00	7.75	9.25	1.50	3.00	.75
7/8 x 5	1044140	238.00	.88	5.00	7.00	8.75	1.75	3.50	.88
7/8 x 8	1044168	291.00	.88	8.00	10.00	11.75	1.75	3.50	.88
1 x 6	1044186	375.00	1.00	6.00	8.38	10.38	2.00	4.00	1.00
1 x 9	1044202	450.00	1.00	9.00	11.38	13.38	2.00	4.00	1.00
1-1/4 x 8	1044220	720.00	1.25	8.00	10.88	13.38	2.50	5.00	1.25
1-1/4 x 12	1044248	855.00	1.25	12.00	14.88	17.38	2.50	5.00	1.25



**S-276**  
Shoulder Rivet Eye Bolt

- Forged steel - Quenched and Tempered.



**S-276 Shoulder Rivet Eye Bolts**

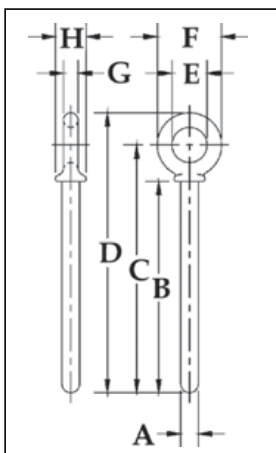

Shank Dia. & Length (in)	S-276 Stock No.	Weight Per 100 (lb)	Dimensions (in)							
			A	B	C	D	E	F	G	H
5/16 x 2-1/4	1045782	6.30	.31	2.25	2.94	3.50	.63	1.13	.25	.56
5/16 x 4-1/4	1045808	14.80	.31	4.25	4.94	5.50	.63	1.13	.25	.56
3/8 x 2-1/2	1045826	18.80	.38	2.50	3.28	3.97	.75	1.38	.31	.66
3/8 x 4-1/2	1045844	25.00	.38	4.50	5.28	5.97	.75	1.38	.31	.66
1/2 x 3-1/4	1045862	33.00	.50	3.25	4.25	5.12	1.00	1.75	.38	.91
1/2 x 6	1045880	50.00	.50	6.00	7.00	7.88	1.00	1.75	.38	.91
5/8 x 4	1045906	68.80	.63	4.00	5.31	6.44	1.25	2.25	.50	1.12
5/8 x 6	1045924	75.00	.63	6.00	7.31	8.44	1.25	2.25	.50	1.12
3/4 x 4-1/2	1045942	125.00	.75	4.50	6.06	7.44	1.50	2.75	.62	1.38
3/4 x 6	1045960	150.00	.75	6.00	7.56	8.94	1.50	2.75	.62	1.38
7/8 x 5	1045988	200.00	.88	5.00	6.84	8.46	1.75	3.25	.75	1.56
1 x 6	1046022	298.00	1.00	6.00	8.09	9.97	2.00	3.75	.88	1.81
1 x 9	1046040	425.00	1.00	9.00	11.09	12.97	2.00	3.75	.88	1.81
1-1/4 x 8	1046068	654.00	1.25	8.00	10.47	12.72	2.50	4.50	1.00	2.28
1-1/4 x 12	1046086	712.00	1.25	12.00	14.47	16.72	2.50	4.50	1.00	2.28
1-1/2 x 15	1046102	1425.00	1.50	15.00	18.00	20.75	3.00	5.50	1.25	2.75

# Pad Eyes



**S-264**  
Pad Eye

- Forged Steel — Quenched and Tempered.
- Forged from 1035 Carbon Steel.
- Excellent welding qualities.
- Widely used on farm machinery, trucks, steel hulled marine vessels and material handling equipment.
- Reference American Welding Society specifications for proper welding procedures.

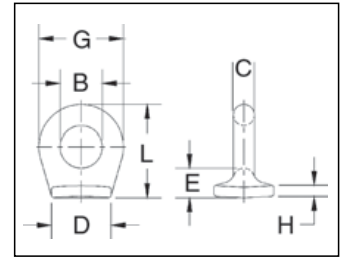

## S-264 Pad Eyes

Size No.*	S-264 Stock No.	Weight Per 100 (lb)	Dimensions (in)						
			B	C	D	E	G	H	L
* 0	1090722	2.80	.25	.19	.63	.31	.63	.09	.75
* 1	1090740	6.50	.38	.25	.88	.41	.88	.13	1.03
* 1-1/2	1090768	10.40	.63	.25	1.00	.44	1.13	.16	1.31
2	1090786	21.10	.75	.38	1.06	.50	1.50	.19	1.63
4	1090802	52.20	1.00	.56	1.44	.78	2.13	.22	2.34
5	1090820	82.50	1.25	.69	1.75	.81	2.63	.25	2.75

\*Meets the requirements of Military Specification MS-51930A



## Forged Eye Nuts



**G-400**  
Eye Nut

- Forged Steel - Quenched and Tempered.
- Hot Dip galvanized.
- Tapped with standard UNC class 2 threads after galvanizing.
- Also available in blank (as forged) item (S-4028) or on request with metric threading ( M-400).
- Recommended for In-Line pull.
- Meets or exceeds all requirements of ASME B30.26 including identification, ductility, design factor, proof load and temperature requirements. Importantly, these products meet other critical performance requirements including fatigue life, impact properties and material traceability, not addressed by ASME B30.26.

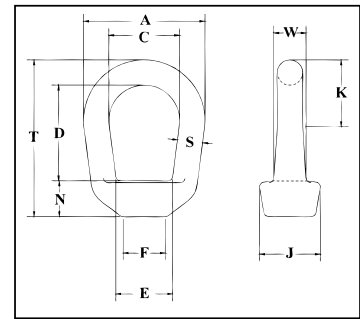

### G-400 Eye Nuts

Size No.	"S" Stock Size (in)	G-400 Stock No	Std. Tap Size (in)	Working Load Limit (lb)*	Weight Each (lb)	Dimensions (in)									
						A	C	D	E	F	J	K	N	T	W
1	.25	1090438	1/4	520	.09	1.25	.75	1.00	.75	.50	.69	.63	.38	1.72	.31
2	.31	1090474	3/8	1250	.17	1.62	1.00	1.20	.83	.56	.81	.89	.50	2.09	.41
3A	.38	1090517	1/2	2250	.28	2.00	1.25	1.44	1.08	.81	1.00	1.09	.62	2.55	.50
4	.50	1090535	5/8	3600	.60	2.50	1.50	1.92	1.35	1.00	1.31	1.31	.69	3.25	.69
5	.63	1090553	3/4	5200	1.00	3.00	1.75	2.38	1.59	1.12	1.50	1.57	.88	3.89	.84
6	.75	1090571	7/8	7200	1.65	3.50	2.00	2.63	1.96	1.38	1.88	1.77	.94	4.32	1.00
7	.88	1090599	1	10000	2.69	4.00	2.25	3.06	2.21	1.56	2.13	2.02	1.07	5.01	1.19
8	1.00	1090633	1-1/4	15500	4.38	4.50	2.50	3.50	2.46	1.88	2.38	2.27	1.25	5.78	1.38
9	1.13	1090651	1-3/8	18500	5.00	5.00	2.75	4.00	2.69	2.00	2.56	2.53	1.38	6.51	1.50
10	1.25	1090679	1-1/2	22500	6.78	5.62	3.12	4.31	3.09	2.25	3.00	2.82	1.50	7.06	1.66
11	1.50	1090697	2	40000	14.60	7.12	4.10	6.20	4.09	3.13	3.75	3.68	2.06	9.91	1.94

\*Working Load Limit shown is for In-Line pull. Ultimate Load is 5 times the Working Load Limit. Rating based on standard tap size.



**S-405**  
Lifting Eye

- Forged Steel — Quenched and Tempered.
- On request: threaded to customer specification

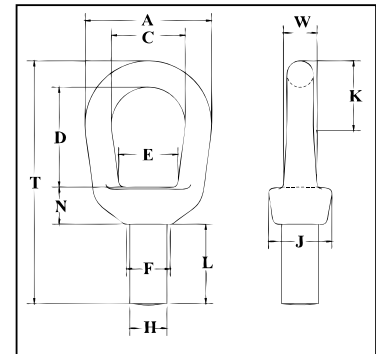

### S-405 Lifting Eyes

Size No.	S-405 Stock No	Working Load Limit Threaded (lb)*	Maximum Thread Diam. (in)	Weight Each (lb)	Dimensions (in)											
					A	C	D	E	F	H †	J	K	L	N	T	W
1	1090269	850	.31	.10	1.25	.75	1.02	.66	.50	.34	.69	.67	.69	.42	2.46	.31
2	1090287	1250	.38	.20	1.62	1.00	1.20	.75	.56	.41	.81	.92	.94	.55	3.00	.41
3	1090303	2250	.50	.50	2.00	1.25	1.44	1.00	.81	.53	1.13	1.13	1.25	.68	3.69	.50
4	1090321	3600	.63	.79	2.50	1.50	1.92	1.19	1.00	.66	1.31	1.38	1.50	.80	4.59	.69
5	1090349	5200	.75	1.25	3.00	1.75	2.28	1.38	1.12	.78	1.50	1.66	1.75	.98	5.55	.84
6	1090367	7200	.88	2.25	3.50	2.00	2.50	1.63	1.38	.91	1.88	1.91	1.88	1.06	6.16	1.00
7	1090385	10000	1.00	3.25	4.00	2.25	2.92	1.88	1.56	1.03	2.13	2.16	2.06	1.20	7.07	1.19
8	1090401	12500	1.13	4.70	4.50	2.50	3.35	1.94	1.88	1.16	2.38	2.47	2.50	1.40	8.16	1.38
10	1090410	18000	1.50	9.33	5.62	3.12	3.81	2.75	2.25	1.53	3.00	2.98	3.21	1.69	9.96	1.66

\*Ultimate Load is 5 times the Working Load Limit. Rating based on UNC thread size shown in Max Thread Diameter column. † Dimension before machining (as forged).

# Crosby Bundle Clip

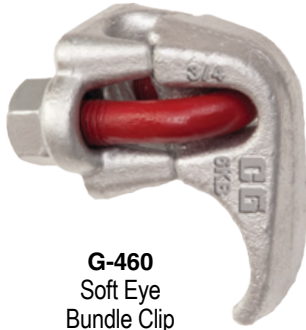

**G-460**  
Soft Eye  
Bundle Clip  
(For use without Thimble)

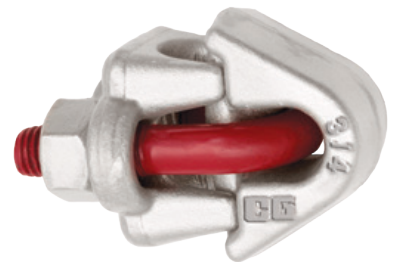

**G-461**  
Thimble  
Eye Bundle Clip

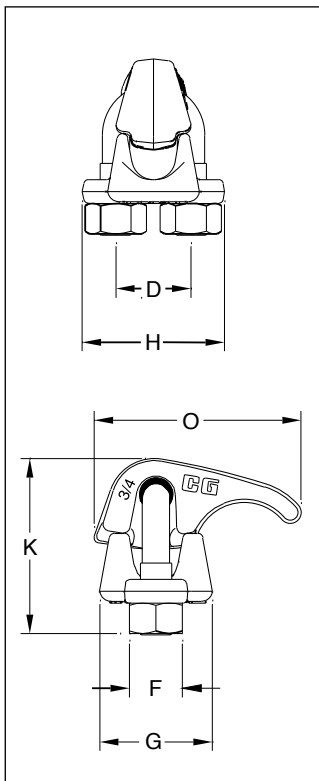

- Each base and Bundle Clip adapter has a Product Identification Code (PIC) for material tracability, the name Crosby or CG, and a size forged into it.
- Entire clip galvanized to resist corrosive and rusting action.
- Forged bases and bundle clip adapters.
- All bundle clips are individually bagged or tagged with proper application instructions and warning information.
- Clips have rolled threads.
- Bundle Clip Adapter for Soft Eye (G4460) and for Thimble Eye (G4461) kits available.
- Look for the Red-U-Bolt, your assurance of Genuine Crosby Products.
- Meets or exceeds all requirements of ASME B30.26 including manufacturing I.D. and size requirements. Importantly, these wire rope bundle clips meet material traceability not addressed by ASME B30.26.

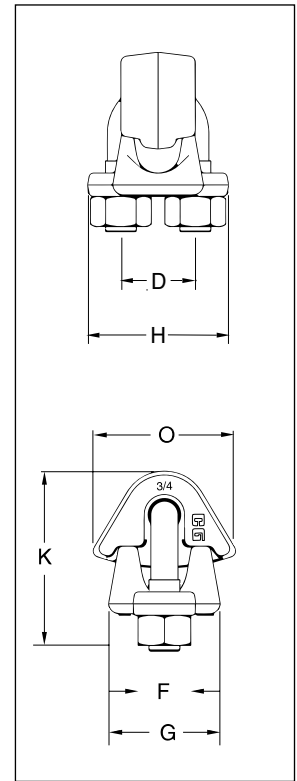

Rigging  
Accessories

## G-460 Soft Eye / G-461 Thimble Eye Bundle Clip

Rope Size		Bundle Clip Style	Stock No.	Dimensions (in)						Weight each (lb)
(in)	(mm)			D	F	G	H	K	O	
3/4	18-20	G460	1010509	1.50	1.06	2.25	2.84	3.50	4.13	2.5
3/4	18-20	G461	1010619	1.50	1.06	2.25	2.84	3.50	2.85	2.5



# Swivel Hoist Ring



**HR-125M**  
Swivel Hoist Ring

Color coded to distinguish between UNC (Red) and Metric (Silver) thread types.



**HR-125**  
Swivel Hoist Ring

- Available in UNC and Metric thread sizes.
  - UNC threads available in sizes from 800 pounds to 100,000 pounds Working Load Limit, with a design factor of 5 to 1.
  - Metric threads available in sizes from 400kg to 16,900kg and dual rated in both a 4 to 1 and 5 to 1 design factor.
- All Components are Alloy Steel - Quenched and Tempered.
- Designed to be used at full WLL within angular loading range.
- 100% individually proof tested to 2-1/2 times the Working Load Limit with certification and Statistically Magnetic Particle inspected. (Can be furnished 100% Magnetic Particle inspected when requested at time of order.)
- Each product has a Product Identification Code (PIC) for material traceability along with a Working Load Limit and the name Crosby or "CG" stamped into it.
- 360° swivel and 180° pivot action.
- Fatigue rated to 20,000 cycles at 1-1/2 times the Working Load Limit.
- Individually packaged along with proper application instructions and warning information.
- Bolt is secured with E-clip, threads are grooved. This method allows for easy disassembly and assembly of hoist ring for thorough examination of all components. Replacement kits are available.
- Bolts are individually Proof Tested.
- Multiple Bolt length available to meet specific application requirements
- Zinc Plated (Yellow Chromate) finish for increased corrosion protection thru 30,000 pound size
- Meets or exceeds all the requirements of ASME B30.26 including identification, ductility, design factor, proof load and temperature requirements. Importantly, these hoist rings meet other critical performance requirements including fatigue life, impact properties and material traceability, not addressed by ASME B30.26.



**Fatigue Rated**



**Load Rated**

# UNC Swivel Hoist Rings



**HR-125**  
Swivel Hoist Ring

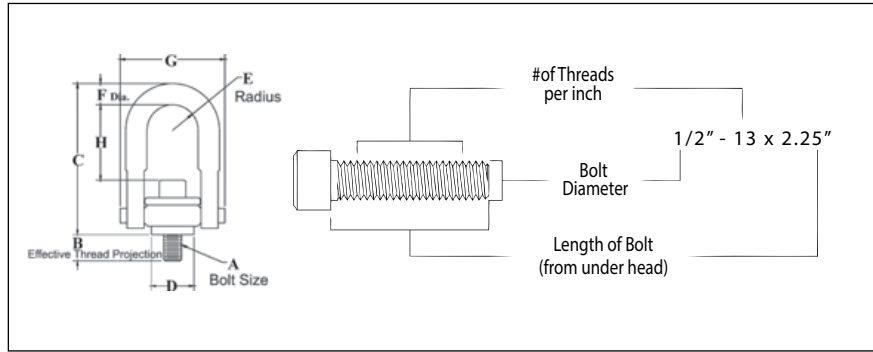

- Top washer has the following features:
  - The Working Load Limit and Recommended Torque value are permanently stamped into each washer.
  - Washer is color coded for easy identification: Red - UNC thread.
- Individually Proof Tested to 2-1/2 times Working Load Limit.
- Bolt specification is an Alloy socket head cap screw to ASTM A 574.
- All threads listed are UNC.
- **BOLT SIZE IDENTIFICATION:** The size of the bolt will be stated as in the drawing above. Illustration shows meaning of each dimension given.
- NOTE: For Special Applications, see page 457.
- Frame 2 and larger are **RFID EQUIPPED**.

Rigging  
Accessories

**Fatigue Rated**



**Load Rated**



## HR-125 UNC Threads

Frame Size No.	HR-125 Stock No.	Working Load Limit (lb)*	Torque in (ft•lbf)	Dimensions (in)								Weight Each (lb)
				Bolt Size A ‡	Effective Thread Projection Length B	C	D	Radius E	Diameter F	G	H	
1 †	1016887	800	7	5/16 - 18 x 1.50	.58	2.72	.97	.46	.34	1.87	1.12	.37
1 †	1016898	1000	12	3/8 - 16 x 1.50	.58	2.72	.97	.46	.34	1.87	1.05	.39
2	1016909	2500	28	1/2 - 13 x 2.00	.70	4.85	1.96	.87	.75	3.35	2.29	2.33
2 †	1016912	2500	28	1/2 - 13 x 2.50	1.20	4.85	1.96	.87	.75	3.35	2.29	2.36
2	1016920	4000	60	5/8 - 11 x 2.00	.70	4.85	1.96	.87	.75	3.35	2.16	2.41
2 †	1016924	4000	60	5/8 - 11 x 2.75	1.45	4.85	1.96	.87	.75	3.35	2.16	2.47
2	1016931	5000	100	3/4 - 10 x 2.25	.95	4.85	1.96	.87	.75	3.35	2.04	2.52
2 †	1016935	5000	100	3/4 - 10 x 2.75	1.45	4.85	1.96	.87	.75	3.35	2.04	2.59
3	1016942	7000 **	100	3/4 - 10 x 2.75	.89	6.57	2.96	1.36	.94	4.87	2.97	6.72
3 †	1016946	7000 **	100	3/4 - 10 x 3.50	1.64	6.57	2.96	1.36	.94	4.87	2.97	6.81
3	1016953	8000	160	7/8 - 9 x 2.75	.89	6.57	2.96	1.36	.94	4.87	2.84	6.84
3 †	1016957	8000	160	7/8 - 9 x 3.50	1.64	6.57	2.96	1.36	.94	4.87	2.84	6.96
3	1016964	10000	230	1 - 8 x 3.00	1.14	6.57	2.96	1.36	.94	4.87	2.72	7.09
3 †	1016969	10000	230	1 - 8 x 4.00	2.14	6.57	2.96	1.36	.94	4.87	2.72	7.31
4	1016975	15000	470	1-1/4 - 7 x 4.50	2.21	8.72	3.71	1.75	1.19	6.18	3.93	14.51
5	1016986	24000	800	1-1/2 - 6 x 6.75	3.00	12.55	4.71	2.39	1.75	8.48	5.52	37.73
5	1016997	30000	1100	2 - 4-1/2 x 6.75	3.00	12.55	4.71	2.39	1.75	8.48	5.02	40.69
6	1017001	50000	2100	2-1/2 - 4 x 8.0	4.00	16.88	5.75	3.00	2.25	11.00	8.03	88.00
7	1017005	75000	4300	3 - 4 x 10.5	5.00	19.50	6.45	3.75	2.75	14.16	8.50	166.00
8	1017009	100000	5100	3-1/2 - 4 x 13.0 #	7.00	22.09	7.75	4.00	3.25	15.91	9.28	265.00

\*Ultimate Load is 5 times the Working Load Limit.

\*\* Ultimate Load is 4.5 times the Working Load Limit for 7000# Hoist Ring when tested in 90 degree orientation.

† Long Bolts are designed to be used with soft metal (i.e., aluminum) workpiece. While the long bolts may also be used with ferrous metal (i.e., steel & iron) workpiece, short bolts are designed for ferrous workpieces only.

‡ Bolt specification is an Alloy socket head cap screw to ASTM A 574.

# Hex head bolt used on Frame 8 (100,000lb.) Hoist Ring.



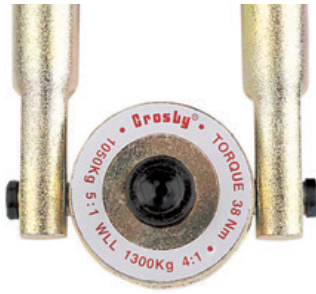

**HR-125M**  
Swivel Hoist Ring

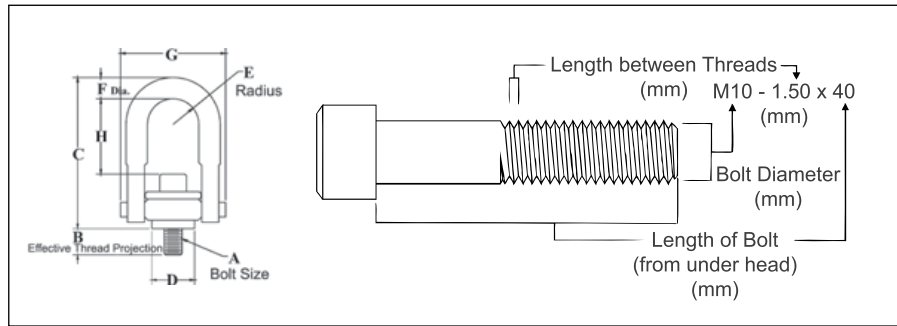

- Top washer has the following features:
  - The Working Load Limit and Recommended Torque value are permanently stamped into each washer.
  - Washer is color coded for easy identification: Silver - Metric thread
- Individually Proof Tested to 2-1/2 times Working Load Limit.
- Bolt specification is a Grade 12.9 Alloy socket head cap screw to Din 912. All threads listed are metric (ASME B18.3.1m).
- Designed to be used with ferrous workpiece only.
- BOLT SIZE IDENTIFICATION: The size of the bolt will be stated as in the drawing above. Illustration shows meaning of each dimension given.
- NOTE: For Special Applications, see page 457.
- Frame 2 and larger RFID EQUIPPED.



**Fatigue Rated**



**Load Rated**



## HR-125M Metric Threads

Frame Size No.	HR-125M Stock No.	Working Load Limit (kg)		Torque in (Nm)*	Dimensions (mm)								Weight Each (kg)
		At a 5:1 Design Factor †	At a 4:1 Design Factor †		(A) Bolt Size ‡	(B) Effective Thread Projection Length	C	D	Radius E	Diameter F	G	H	
1	1016602	400	500	10	M8X1.25X40	16.9	69.9	24.6	11.8	8.5	47.5	29.9	.17
1	1016613	450	550	16	M10X1.50X40	16.9	69.9	24.6	11.8	8.5	47.5	28.1	.18
2	1016624	1050	1300	38	M12X1.75X50	16.9	123	49.8	22.3	17.5	85.1	60.4	1.05
2	1016635	1900	2400	81	M16X2.00X60	26.9	123	49.8	22.3	17.5	85.1	56.3	1.11
2	1016644	2150	2700	136	M20X2.50X65	31.9	123	49.8	22.3	17.5	85.1	52.3	1.17
3	1016657	3000	3750	136	M20X2.50X75	27.8	167	75.2	34.7	25.4	124	76.6	3.09
3	1016668	4200	5250	312	M24X3.00X80	32.8	167	75.2	34.7	25.4	124	70.5	3.21
4	1016679	7000	8750	637	M30X3.50X120	61.7	222	94.2	44.5	30.5	157	102	6.53
5	1016690	11000	13750	1005	M36X4.00X150	54.0	318	120	60.7	44.5	215	142	16.8
5	1016701	12500	15600	1005	M42X4.50X160	64.0	318	120	60.7	44.5	215	136	17.4
5	1016712	13500	16900	1350	M48X5.00X160	74.0	318	120	60.7	44.5	215	130	18.0

\*The tightening torque values shown are based upon threads being clean, dry and free of lubrication.

† Individually proof loaded to 2-1/2 times the Working Load Limit based on the 4:1 design factor.

‡ Bolt specification is a Grade 12.9 Alloy socket head cap screw to Din 912. All threads are metric (ASME/ANSI B18.3.1m).

# Heavy Lift Swivel Hoist Rings



HR-1000

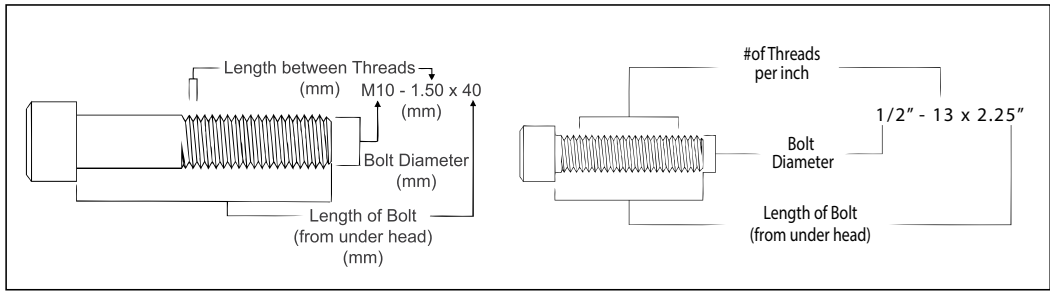

- Forged bail provides the following:
  - Easily readable "Raised Lettering" showing the name Crosby or "CG" and PIC Code for material traceability.
  - Greater durability providing the increased "Toughness" desired in potentially abusive field conditions
  - Larger opening than standard Hoist Ring bail.
- Top washer is color coded for easy identification (Red for UNC threads and Silver for Metric threads)
- The Working Load Limit and Recommended Torque value are permanently stamped into each washer.
- Individually Proof Tested to 2-1/2 times Working Load Limit.
- Available in both UNC Thread and Metric Thread style.
- **BOLT SIZE IDENTIFICATION:** The size of the bolt will be stated as in the drawing below. Illustration shows meaning of each dimension given.
- **NOTE:** For Special Applications, see page 457.
- Frame 2 and larger are **RFID EQUIPPED**.

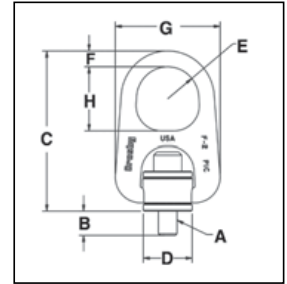

**Fatigue Rated**



**Load Rated**

**SEE APPLICATION AND WARNING INFORMATION**  
On Pages 210 - 211  
Para Español: [www.thecrosbygroup.com](http://www.thecrosbygroup.com)

Rigging Accessories

## HR-1000 UNC Threads

Frame Size No.	HR-1000 Stock No.	Working Load Limit (lb)*	Torque in (ft•lbf)	Dimensions (in)								Weight Each (lb)
				Bolt Size A ‡	Eff. Thread Projection Length B	C	D	Radius E	F	G	H	
1	1068002	800	7	5/16 - 18 x 1.50	.52	3.69	.97	.62	.44	2.27	1.38	.60
1	1068006	1000	12	3/8 - 16 x 1.50	.52	3.69	.97	.62	.44	2.27	1.38	.62
2	1068010	2500	28	1/2 - 13 x 2.25	.69	6.26	1.96	1.25	.75	4.20	2.50	3.05
2 †	1068014	2500	28	1/2 - 13 x 2.75	1.19	6.26	1.96	1.25	.75	4.20	2.50	3.07
2	1068018	4000	60	5/8 - 11 x 2.25	.69	6.26	1.96	1.25	.75	4.20	2.50	3.11
2 †	1068022	4000	60	5/8 - 11 x 3.00	1.44	6.26	1.96	1.25	.75	4.20	2.50	3.18
2	1068026	5000	100	3/4 - 10 x 2.50	.94	6.26	1.96	1.25	.75	4.20	2.50	3.24
2 †	1068030	5000	100	3/4 - 10 x 3.00	1.44	6.26	1.96	1.25	.75	4.20	2.50	3.30
3	1068034	7000 **	100	3/4 - 10 x 3.00	.85	8.66	2.96	1.63	1.00	6.25	3.25	10.09
3 †	1068038	7000 **	100	3/4 - 10 x 3.50	1.35	8.66	2.96	1.63	1.00	6.25	3.25	10.21
3	1068042	8000	160	7/8 - 9 x 3.00	.85	8.66	2.96	1.63	1.00	6.24	3.25	10.21
3 †	1068046	8000	160	7/8 - 9 x 3.50	1.35	8.66	2.96	1.63	1.00	6.24	3.25	10.40
3	1068050	10000	230	1 - 8 x 3.50	1.35	8.66	2.96	1.63	1.00	6.24	3.25	10.50
3 †	1068054	10000	230	1 - 8 x 4.50	2.35	8.66	2.96	1.63	1.00	6.24	3.25	10.72
4	1068058	15000	470	1-1/4 - 7 x 5.00	2.09	11.21	3.71	2.00	1.25	7.82	4.00	21.90
4	1068062	24000	800	1-1/2 - 6 x 5.50	2.59	11.21	3.71	2.00	1.44	7.82	4.00	23.00

## HR-1000M Metric Threads

Frame Size No.	HR-1000M Stock No.	Working Load Limit (kg)*		Torque in (Nm)	Dimensions (mm)								Weight Each (kg)
		At a 5:1 Design Factor***	At a 4:1 Design Factor***		Bolt Size A ‡	Eff. Thread Projection Length B	C	D	Radius E	F	G	H	
1	1068307	400	500	10	M8 x 1.25 x 40	15.2	93.7	24.6	15.7	11.2	57.7	35.1	.3
1	1068316	450	550	16	M10 x 1.50 x 40	15.2	93.7	24.6	15.7	11.2	57.7	35.1	.3
2	1068325	1050	1300	38	M12 x 1.75 x 55	15.5	162	49.8	31.8	19.1	107	63.5	1.5
2	1068334	1900	2400	81	M16 x 2.00 x 65	25.5	162	49.8	31.8	19.1	107	63.5	1.5
2	1068343	2150	2700	136	M20 x 2.50 x 70	30.5	162	49.8	31.8	19.1	107	63.5	1.6
3	1068352	3000	3750	136	M20 x 2.50 x 80	25.4	220	75.2	41.4	25.4	159	82.6	4.6
3	1068361	4200	5250	312	M24 x 3.00 x 90	35.4	220	75.2	41.4	25.4	159	82.6	4.8
4	1068370	7000**	8750	637	M30 x 3.50 x 140	66.2	285	94.2	50.8	31.8	199	102	9.7
4	1068389	11000	13750	1005	M36 x 4.00 x 130	56.2	285	94.2	50.8	31.8	199	102	10.2

\*Ultimate Load is 5 times the Working Load Limit. \*\* Ultimate Load is 4.5 times the Working Load Limit for 7000# Hoist Ring when tested in 90 degree orientation. \*\*\* Individually proof loaded to 2-1/2 times the Working Load Limit based on the 4:1 design factor. † Long Bolts are designed to be used with soft metal (i.e., aluminum) workpiece. While the long bolts may also be used with ferrous metal (i.e., steel & iron) workpiece, short bolts are designed for ferrous workpieces only. ‡ Bolt specification is an Alloy socket head cap screw to ASTM A 574. †† Bolt specification is a Grade 12.9 Alloy socket head cap screw to DIN 912. NOTE: The tightening torque values shown are based upon threads being clean, dry and free of lubrication.

# Heavy Lift Swivel Hoist Rings

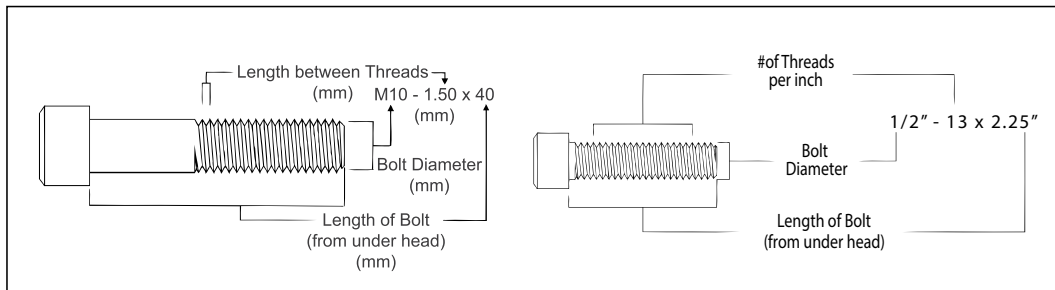

**HR-1000CT**

- All load bearing components are heat treated, Quenched & Tempered alloy steel.
- All components, with the exception of the retaining ring, are produced with maximum material hardness of 34 HRc. All primary load bearing components have Charpy impact testing. The body, bushing, washer and bail meet impact requirements of 31 ft-lbs min. avg. at -4°F. The bolt meets impact requirements of 20 ft-lbs min. avg. at -150°F.
- Individually Mag inspected with certification
- Forged bail provides the following:
  - Easily readable raised lettering showing the name Crosby or "CG" and PIC Code for material traceability.
  - Greater durability providing the increased "Toughness" desired in potentially abusive field conditions
  - Larger opening than standard Hoist Ring bail.
- Top washer is color coded for easy identification (blue for UN threads and grey for Metric threads)
- The Working Load Limit and Recommended Torque value are permanently stamped into each washer.
- Individually Proof Tested to 2 times Working Load Limit (90° and in-line).
- **BOLT SIZE IDENTIFICATION:** The size of the bolt will be stated as in the drawing above. Illustration shows meaning of each dimension given.
- **NOTE:** For Special Applications, see page 457.
- Type approval and certification in accordance with DNV offshore Standard DNV-OS-E101, Drilling Plant, October 2013 and Standard for Certification No. 2.22 Lifting Appliances.
- Frame 2 and larger are **RFID EQUIPPED**.
- Individually serialized.
- 100% MPI all primary load bearing components.
- Coating: Thermo-diffusion galvanized.
- Optional bolt sizes available upon request.

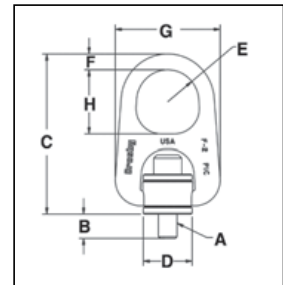

**Fatigue Rated**



**Load Rated**

**SEE APPLICATION AND WARNING INFORMATION**  
On Pages 210 - 211  
Para Español: [www.thecrosbygroup.com](http://www.thecrosbygroup.com)

## HR-1000CT UN Threads

Frame Size No.	HR-1000CT Stock No.	Working Load Limit (lb)*	Torque (ft•lbf)	Dimensions (in)								Mass Each (lb)
				Bolt Size A ‡	Eff. Thread Projection Length B	C	D	Radius E	Diameter F	G	H	
2	6608103	1900	28	1/2 - 13 x 2.25	0.70	6.32	1.96	1.25	0.75	4.20	2.50	3
2	6608112	1900	28	1/2 - 13 x 2.75	1.20	6.32	1.96	1.25	0.75	4.20	2.50	3
2	6608121	3000	60	5/8 - 11 x 2.25	0.70	6.32	1.96	1.25	0.75	4.20	2.50	3
3	6608130	4800	100	3/4 - 10 x 3.00	0.85	8.59	2.96	1.63	1.00	6.25	3.25	11
3	6608139	6200	160	7/8 - 9 x 3.00	0.85	8.59	2.96	1.63	1.00	6.25	3.25	11
3	6608148	8300	230	1 - 8 x 3.50	1.35	8.59	2.96	1.63	1.00	6.25	3.25	11
4	6608149	12500	470	1-1/4 - 7 x 5.00	2.10	11.31	3.71	2.00	1.44	8.13	4.00	24
4	6607669	20000	800	1-1/2 - 6 x 5.50	2.60	11.31	3.71	2.00	1.44	8.13	4.00	27
4	6607727	20000	800	1-1/2 - 8 x 5.50	2.60	11.31	3.71	2.00	1.44	8.13	4.00	27
5	6607670	28000	1100	2 - 4.5 x 7.50	3.20	15.15	4.00	2.69	1.75	11.64	5.00	69
6	6607671	45000	2100	2 1/2 - 4 x 9.50	3.73	19.93	5.75	3.00	2.75	14.47	5.62	157

\*Ultimate Load is 5 times the Working Load Limit. ‡ Bolt specification is an Alloy socket head cap screw to ASTM A320 Grade L7 or L43.  
NOTE: The tightening torque values shown are based upon threads being clean, dry and free of lubrication.

# Heavy Lift Swivel Hoist Rings

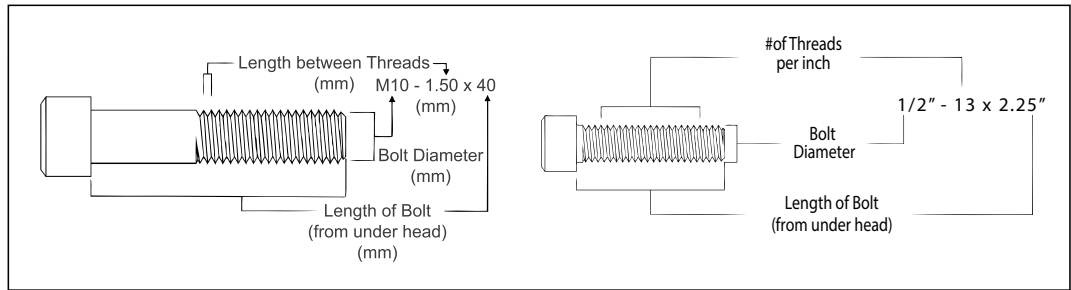

## HR-1000MCT

- All load bearing components are heat treated, Quenched & Tempered alloy steel.
- All components, with the exception of the retaining ring, are produced with maximum material hardness of 34 HRC. All primary load bearing components have Charpy impact testing. The body, bushing, washer and bail meet impact requirements of 31 ft-lbs min. avg. at -4°F. The bolt meets impact requirements of 20 ft-lbs min. avg. at -150°F.
- Individually Mag inspected with certification
- Forged bail provides the following:
  - Easily readable raised lettering showing the name Crosby or "CG" and PIC Code for material traceability.
  - Greater durability providing the increased "Toughness" desired in potentially abusive field conditions
  - Larger opening than standard Hoist Ring bail.
- Top washer is color coded for easy identification (blue for UNC threads and grey for Metric threads)
- The Working Load Limit and Recommended Torque value are permanently stamped into each washer.
- Individually Proof Tested to 2 times Working Load Limit (90° and in-line).
- **BOLT SIZE IDENTIFICATION:** The size of the bolt will be stated as in the drawing above. Illustration shows meaning of each dimension given.
- **NOTE:** For Special Applications, see page 457.
- Type approval and certification in accordance with DNV O fshore Standard DNV-OS-E101, Drilling Plant, October 2013 and Standard for Certification No. 2.22 Lifting Appliances.
- Frame 2 and larger are **RFID EQUIPPED**.
- Individually serialized.
- 100% MPI all primary load bearing components.
- Coating: Thermo-diffusion galvanized.
- Optional bolt sizes available upon request.

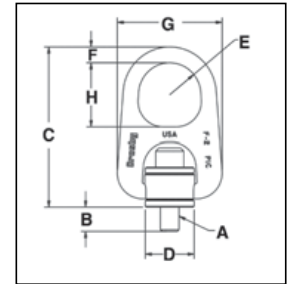

Rigging Accessories

**Fatigue Rated**



**Load Rated**



## HR-1000MCT Metric Threads

Frame Size No.	HR-1000MCT Stock No.	Working Load Limit (kg)*		Torque (Nm)	Dimensions (mm)								Mass Each (kg.)
		Design Factor 5:1	Design Factor 4:1		Bolt Size A ‡	Eff. Thread Projection Length B	C	D	Radius E	Diameter F	G	H	
2	6630058	825	1,030	38	M12 x 1.75 x 55	15.6	160.6	49.7	31.8	19.1	106.7	63.5	1
2	6630059	1,350	1,690	81	M16 x 2.00 x 65	25.5	160.6	49.7	31.8	19.1	106.7	63.5	1
3	6630060	2,250	2,810	136	M20 x 2.50 x 80	25.3	218.2	75.1	41.4	25.4	158.8	82.6	5
3	6630061	3,175	3,970	312	M24 x 3.00 x 90	35.4	218.2	75.1	41.4	25.4	158.8	82.6	5
4	6630062	5,450	6,810	637	M30 x 3.50 x 140	65.9	287.3	94.1	50.8	36.6	206.5	101.6	11
4	6630063	7,450	9,310	1,005	M36 x 4.00 x 130	56.3	287.3	94.1	50.8	36.6	206.5	101.6	12
5	6630064	13,250	16,560	1,350	M48 x 5.00 x 180	70.7	384.9	101.6	68.3	44.5	295.6	127.0	30

\*Ultimate Load is 5 times the Working Load Limit. ‡ Bolt specification is an Alloy socket head cap screw to ASTM A320 Grade L7 or L43.  
NOTE: The tightening torque values shown are based upon threads being clean, dry and free of lubrication.



# Stainless Steel Swivel Hoist Rings

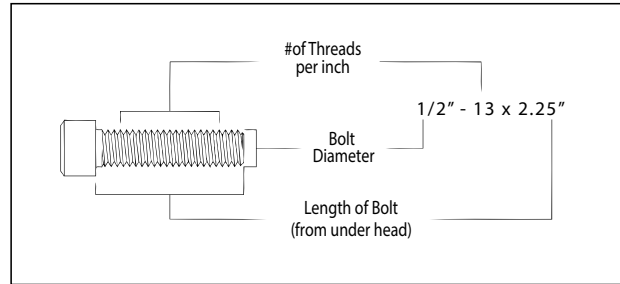
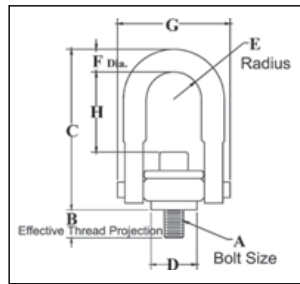

## SS-125UNC

- All components are 316 stainless steel, except bolt retainers, which are made from 15-7 PH (UNS 15700) magnetic stainless steel.
- Available in capacities from 400 lbs. to 50,000 lbs.
- Rated at 100 percent at 90 degree angle.
- Each product has a Product Identification Code (PIC) for material traceability, along with the Working Load Limit and the name Crosby or "CG" stamped into it.
- Individually proof tested to 2 times the Working Load Limit with certification
- Fatigue Rated to 20,000 cycles at 1-1/2 times the Working Load Limit.
- Washer is color coded for easy identification (Red - UNC thread)
- Bolt specification is 316 Stainless Steel socket head cap screw to ASTM F 837M (316).
- All threads listed are Metric UNC.
- **BOLT SIZE IDENTIFICATION:** The size of the bolt will be stated as in the drawing above. Illustration shows meaning of each dimension given.
- **NOTE:** For Special Applications, see page 457.
- Frame 2 and larger are **RFID EQUIPPED**.

**Fatigue Rated**



**Load Rated**

**SEE APPLICATION AND WARNING INFORMATION**

On Pages 210 -211  
Para Español: [www.thecrosbygroup.com](http://www.thecrosbygroup.com)

## SS-125UNC Threads

Frame Size No.	SS-125UNC Stock No.	Working Load Limit (lb)*	Torque (ft-lbs)	Dimensions (in)								Weight Each (lb)
				Bolt Size A ‡	Effective Thread Projection Length B	C	D	Radius E	Diameter F	G	H	
1	1065000	400	3.5	5/16 - 18 x 1.0	.29	2.67	.85	.43	.34	1.84	1.27	.30
1	1065004	400	3.5	5/16 - 18 x 1.25	.54	2.67	.85	.43	.34	1.84	1.27	.30
1	1065008	500	6	3/8 - 16 x 1.25	.54	2.67	.85	.43	.34	1.84	1.27	.30
2	1065016	1250	14	1/2 - 13 x 2.0	.78	4.78	1.45	.88	.69	3.52	2.31	2.6
2	1065020	1250	14	1/2 - 13 x 2.25	1.03	4.78	1.45	.88	.69	3.52	2.31	2.6
2	1065024	1250	14	1/2 - 13 x 2.5	1.28	4.78	1.45	.88	.69	3.52	2.31	2.6
2	1065028	2000	30	5/8 - 11 x 2.0	.78	4.78	1.45	.88	.69	3.52	2.18	2.6
2	1065032	2000	30	5/8 - 11 x 2.25	1.03	4.78	1.45	.88	.69	3.52	2.18	2.6
2	1065036	2000	30	5/8 - 11 x 2.5	1.28	4.78	1.45	.88	.69	3.52	2.18	2.6
2	1065040	2500	50	3/4 - 10 x 2.25	1.03	4.78	1.45	.88	.69	3.52	2.06	3.0
2	1065044	2500	50	3/4 - 10 x 2.75	1.53	4.78	1.45	.88	.69	3.52	2.06	3.0
3	1065048	3500	50	3/4 - 10 x 2.75	1.04	6.52	2.20	1.40	.94	5.14	3.06	7.0
3	1065052	3500	50	3/4 - 10 x 3.25	1.54	6.52	2.20	1.40	.94	5.14	3.06	7.0
3	1065056	4000	80	7/8 - 9 x 2.75	1.04	6.52	2.20	1.40	.94	5.14	2.93	7.0
3	1065060	4000	80	7/8 - 9 x 3.0	1.29	6.52	2.20	1.40	.94	5.14	2.93	7.0
3	1065064	5000	115	1 - 8 x 3.0	1.29	6.52	2.20	1.40	.94	5.14	2.81	7.5
3	1065068	5000	115	1 - 8 x 3.25	1.54	6.52	2.20	1.40	.94	5.14	2.81	7.5
3	1065072	5000	115	1 - 8 x 4.0	2.29	6.52	2.20	1.40	.94	5.14	2.81	7.5
4	1065080	7500	235	1-1/4 - 7 x 4.0	1.89	8.73	3.19	1.75	1.25	6.50	4.12	14.0
5	1065084	12000	400	1-1/2 - 6 x 5.5	2.70	12.47	4.87	2.25	1.75	8.55	6.41	34.0
5	1065088	15000	550	2 - 4.5 x 5.75	2.96	12.47	4.87	2.25	1.75	8.55	5.91	36.0
6	1065092	25000	1050	2-1/2 - 4 x 8.0	4.00	16.87	6.52	3.00	2.25	11.67	8.03	88.0
6	1065096	25000	1050	2-1/2 - 8 x 8.0	4.00	16.87	6.52	3.00	2.25	11.67	8.03	88.0
7	1065100	37500	2150	3 - 4 x 10.25	5.00	19.50	8.10	3.75	2.75	14.15	8.48	166.0
8	1065104	50000	2550	3-1/2 - 4 x 13	7.00	22.09	8.60	4.00	3.25	15.90	9.28	265.0

\*Ultimate Load is 5 times the Working Load Limit.

‡ Bolt specification is 316 Stainless Steel socket head cap screw to ASTM F 837 Group 1 (316).

# Stainless Steel Swivel Hoist Rings



SS-125M

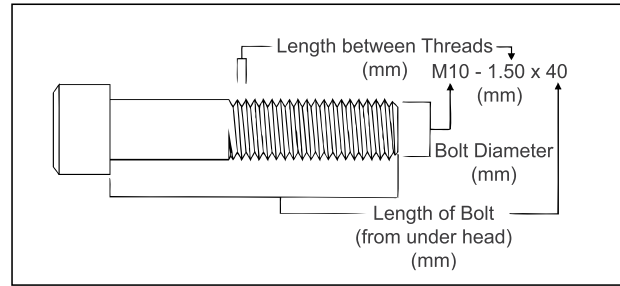
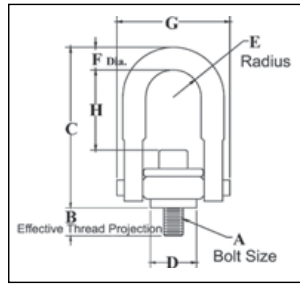

- All components are 316 stainless steel, except bolt retainers, which are made from 15-7 PH (UNS 15700) magnetic stainless steel.
- Available in capacities from 200 kg to 22.300 kg.
- Rated at 100 percent at 90 degree angle.
- Each product has a Product Identification Code (PIC) for material traceability, along with the Working Load Limit and the name Crosby or "CG" stamped into it.
- Individually proof tested to 2 times the Working Load Limit with certification
- Fatigue Rated to 20,000 cycles at 1-1/2 times the Working Load Limit.
- Washer is color coded for easy identification (Silver - Metric thread)
- Bolt specification is 316 Stainless Steel socket head cap screw to ASTM F 837M (316).
- All threads listed are Metric (ASME/ANSI B18.3.1M).
- **BOLT SIZE IDENTIFICATION:** The size of the bolt will be stated as in the drawing above. Illustration shows meaning of each dimension given.
- **NOTE:** For Special Applications, see page 457.
- Frame 2 and larger are **RFID EQUIPPED**.

Rigging Accessories

**Fatigue Rated**  **Load Rated**

**SEE APPLICATION AND WARNING INFORMATION**  
On Pages 210 -211  
Para Español: [www.thecrosbygroup.com](http://www.thecrosbygroup.com)

## SS-125M Metric Threads

Frame Size No.	SS-125M Stock No.	Working Load Limit (kg)*	Torque in (Nm)	Dimensions (mm)								Weight Each (kg)
				Bolt Size A ‡	Effective Thread Projection Length B	C	D	Radius E	Diameter F	G	H	
1	1065203	200	4	M8 x 1.25	13	68	21.6	11	8.5	47	32	.17
1	1065207	250	8	M10 x 1.50	18	68	21.6	11	8.5	47	30	.17
2	1065211	525	18	M12 x 1.75	19	121	37	22	17.5	89	60	1.1
2	1065215	950	40	M16 x 2.00	29	121	37	22	17.5	89	56	1.1
2	1065219	1075	68	M20 x 2.50	34	121	37	22	17.5	89	52	1.2
3	1065223	1500	68	M20 x 2.50	32	166	56	36	25	131	78	3.0
3	1065227	2100	108	M24 x 3.00	37	166	56	36	25	131	74	3.1
3	1065231	2100	108	M30 x 3.50	58	206	56	36	25	131	108	3.1
4	1065235	3500	318	M30 x 3.50	42	222	81	45	31	165	106	6.3
4	1065239	3500	318	M30 x 3.50	62	222	81	45	31	165	106	6.4
5	1065243	5500	542	M36 x 4.00	64	317	124	57	43	217	166	15.5
5	1065247	6250	542	M42 x 4.50	82	317	124	57	43	217	160	16.0
5	1065251	6750	542	M48 x 5.00	82	317	124	57	43	217	154	16.8
6	1065255	11150	1423	M64 x 6.00	101	428	165	76	56	296	204	39.0
7	1065259	15750	2915	M72 x 6.00	132	495	206	95	69	359	220	74.0
8	1065263	22300	3459	M90 x 6.00	177	561	216	102	83	404	235	118.0

\*Ultimate Load is 5 times the Working Load Limit. ‡ Bolt specification is 316 Stainless Steel socket head cap screw to ASTM F 837M Group 1 (316).

## Trench Cover Hoist Rings



HR-500

- Designed to simplify the lifting and placement of steel plates used to cover trenches in streets.
- Provides a standard fitting to be used in place of products not designed for trench cover applications.
- Capacities of 5,000, 10,000 & 15,000 lbs. for plate thicknesses of 3/4" to 1-1/2".
- Detailed welding instructions included with every hoist ring.
- Forged bail provides the following:
  - Easily readable raised lettering showing the name Crosby or "CG" and PIC code for material traceability.
  - More durability provides the increased "Toughness" desired in potentially abusive field conditions
- 180 degree pivot and 360 degree rotation at full capacity.
- Design Factor of 5 to 1.
- Individually Proof Tested to 2-1/2 times Working Load Limit.
- All sizes are **RFID EQUIPPED**.

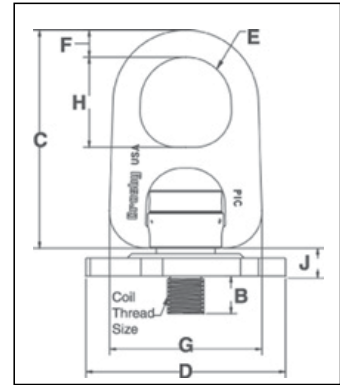

Load Rated



### HR-500 Trench Cover Hoist Rings Coil Threads

HR-500 Stock No.	Working Load Limit (lb)*	Weight Each (lb)	Dimensions (in)								
			Coil Thread Size A	Effective Thread Projection Length B	C	D	Radius E	F	G	H	J
1017907	5000	5.6	1" - 3.5	1.00	5.90	5.50	1.25	.75	4.20	2.50	.77
1017916	10000	15.7	1-1/4" - 3.5	1.00	8.27	7.00	1.63	1.00	6.25	3.25	.81
1017925	15000	29.8	1-1/2" - 3.5	1.50	10.63	9.13	2.00	1.25	7.82	4.00	.80

\*Ultimate Load is 5 times the Working Load Limit.



HRN-500

### HRN-500 Trench Cover Nuts

HRN-500 Stock No.	Working Load Limit (lb)	Weight Each (lb)	Coil Thread Size	Dimensions (in)		
				Nut Diam. K	Trench Cover Hole Diam. L	Nut Thickness M
1063405	5000	1.2	1" - 3.5	3.00	3.12	.75
1063414	5000	1.4	1" - 3.5	3.00	3.12	.88
1063423	5000	1.6	1" - 3.5	3.00	3.12	1.00
1063432	10000	1.1	1-1/4" - 3.5	3.00	3.12	.75
1063441	10000	1.3	1-1/4" - 3.5	3.00	3.12	.88
1063450	10000	1.5	1-1/4" - 3.5	3.00	3.12	1.00
1063454	10000	1.9	1-1/4" - 3.5	3.00	3.12	1.25
1063458	10000	2.3	1-1/4" - 3.5	3.00	3.12	1.50
1063469	15000	2.0	1-1/2" - 3.5	3.50	3.62	1.00
1063478	15000	2.6	1-1/2" - 3.5	3.50	3.62	1.25
1063487	15000	3.1	1-1/2" - 3.5	3.50	3.62	1.50

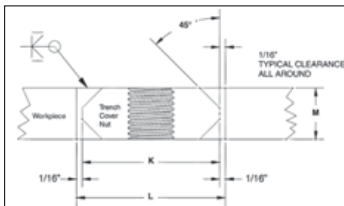

## Trench Cover Lifting Ring Tools and Accessories



### HR-500HG Hole Gauge

Aids in determining when studs and plate nuts need replacing.

Coil Thread Size (in)	HR-500HG Stock No.	Weight Each (lb)
1.00 - 3.5	1064666	.6
1.25 - 3.5	1064675	.8
1.50 - 3.5	1064684	1.0



### HR-500TC Thread Clean-Up Tool

Cleans dirt and other material as from nut threads.

Coil Thread Size (in)	HR-500TC Stock No.	Weight Each (lb)
1.00 - 3.5	1064639	1.2
1.25 - 3.5	1064648	1.7
1.50 - 3.5	1064657	1.9



### HR-500WF Weld Fixture

Holds nut securely in place to ease in initial tack welding.

Coil Thread Size (in)	HR-500WF Stock No.	Weight Each (lb)
1.00 - 3.5	1064602	1.8
1.25 - 3.5	1064611	2.1
1.50 - 3.5	1064620	2.5

# Pivot Hoist Rings



HR-100 UNC

- Forged bail provides the following:
  - Easily readable raised lettering showing the name Crosby or "CG" and PIC code for material traceability.
  - More durability provides the increased "Toughness" desired in potentially abusive field conditions
  - Larger opening than standard Hoist Ring bails.
- 180 degree pivot action at full capacity.
- Bolts included as part of assembly.
- Design Factor of 5 to 1.
- Individually Proof Tested to 2-1/2 times Working Load Limit.
- UNC Bolt specification is a Grade 8 Alloy socket head cap screw to ASTM A 574.
- Frame 2 and larger are **RFID EQUIPPED**.

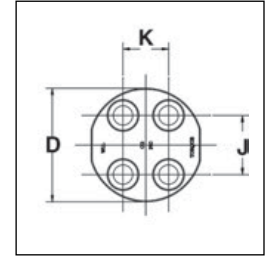
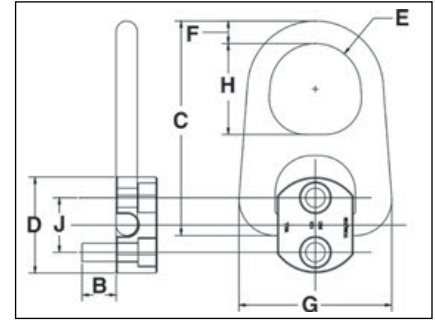

Rigging Accessories

## HR-100 Pivot Hoist Rings Coil Threads

Frame Size No.	HR-100 Stock No.	Working Load Limit (lb)*	Torque in (ft•lbf)	No. of Bolts	Weight Each (lb)	Dimensions (in)									
						Bolt Size A	Effective Thread Projection Length B	C	Diameter D	Radius E	F	G	H	J	K
1	1067408	2000	7	2	.6	5/16-18 x 1.25	.82	3.43	2.00	.62	.44	2.27	1.38	1.00	-
2	1067417	2500	12	2	3.1	3/8-16 x 1.25	.65	6.03	2.25	1.25	.75	4.20	2.50	1.13	-
2	1067426	5000	28	2	3.3	1/2-13 x 2.00	1.40	6.03	2.63	1.25	.75	4.20	2.50	1.50	-
3	1067435	12000	28	4	10.5	1/2-13 x 2.75	1.65	8.27	3.13	1.63	1.00	6.25	3.25	1.63	1.25
4	1067444	20000	60	4	22.0	5/8-11 x 3.25	1.65	10.63	4.47	2.00	1.25	7.82	4.00	2.06	1.25

\*Ultimate Load is 5 times the Working Load Limit.



# HR-1200 Side Pull Hoist Rings



HR-1200

- Wide range of capacities available:
  - 650 lbs. to 29,000 lbs.
  - Metric sizes from 0.3 tonnes to 13 tonnes.
- Body components are Alloy Steel - Quenched and Tempered.
- Rated at 100% of Working Load Limit for angles up to 90 degrees.
- Each product is stamped with a Product Identification Code (PIC) for material traceability, along with a Working Load Limit, and the name Crosby or "CG".
- Hoist Ring body is furnished with Yellow Chromate finish for improved corrosion resistance.
- Utilize standard Crosby Red Pin® Shackles to connect to wire rope or synthetic slings. (sold separately)
- Multiple bolt lengths available to meet specific application requirements
- Individually Proof Tested to 2-1/2 times Working Load Limit.
- All sizes are **RFID EQUIPPED**.

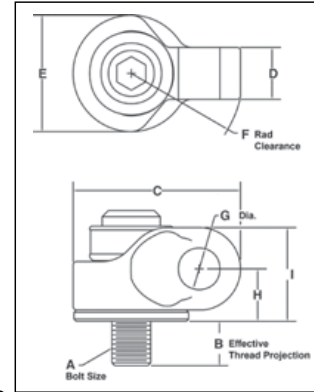

## HR-1200 UNC Side Pull Hoist Rings

Weight Each (lb)	Working Load Limit (lb)*	HR-1200 Stock No.	Hoist Ring Bolt Torque (ft-lbf)	Bolt Size A	Eff. Thread Proj. (in) B	Dimensions (in)							Recommended Shackles			
						C	D	E	F	Dia. G	H	I	Red Pin® Shackles 209,210,213, 215,2130,2150		Red Pin Web Shackles S-281	
													Nominal Size (in)	WLL (t)	Web Size (in)	WLL (t)
.35	650	1067700	7	5/16-18x1.50	.59	1.93	.72	1.00	1.56	.80	.85	1.43	1/2, 5/8	2, 3-1/4	2	3-1/4
.36	800	1067704	12	3/8-16x1.50	.59	1.93	.72	1.00	1.56	.80	.85	1.43	1/2, 5/8	2, 3-1/4	2	3-1/4
1.4	2000	1067708	28	1/2-13x2.00	.71	2.97	.97	2.00	2.13	.93	1.07	1.79	5/8, 3/4	3-1/4, 4-3/4	2, 1.5	3-1/4, 4-1/2
1.4	2000	1067712	28	1/2-13x2.50	1.21	2.97	.97	2.00	2.13	.93	1.07	1.79	5/8, 3/4	3-1/4, 4-3/4	2, 1.5	3-1/4, 4-1/2
1.5	3000	1067716	60	5/8-11x2.00	.71	2.97	.97	2.00	2.13	.93	1.07	1.79	5/8, 3/4	3-1/4, 4-3/4	2, 1.5	3-1/4, 4-1/2
1.5	3000	1067720	60	5/8-11x2.75	1.46	2.97	.97	2.00	2.13	.93	1.07	1.79	5/8, 3/4	3-1/4, 4-3/4	2, 1.5	3-1/4, 4-1/2
4.5	5000	1067724	100	3/4-10x2.75	.90	4.32	1.34	3.00	3.00	1.07	1.35	2.42	7/8	6-1/2	2	6-1/4
4.6	5000	1067728	100	3/4-10x3.50	1.65	4.32	1.34	3.00	3.00	1.07	1.35	2.42	7/8	6-1/2	2	6-1/4
4.6	6500	1067732	160	7/8-9x2.75	.90	4.32	1.34	3.00	3.00	1.07	1.35	2.42	7/8	6-1/2	2	6-1/4
4.8	6500	1067736	160	7/8-9x3.50	1.65	4.32	1.34	3.00	3.00	1.07	1.35	2.42	7/8	6-1/2	2	6-1/4
4.8	8000	1067740	230	1-8x3.00	1.15	4.32	1.34	3.00	3.00	1.07	1.35	2.42	7/8	6-1/2	2	6-1/4
5.0	8000	1067744	230	1-8x4.00	2.15	4.32	1.34	3.00	3.00	1.07	1.35	2.42	7/8	6-1/2	2	6-1/4
10.2	14000	1067748	470	1-1/4-7x4.5	2.22	5.59	1.57	3.75	3.91	1.47	1.92	3.42	1, 1-1/8, 1-1/4	8-1/2, 9-1/2, 12	3	8-1/2
23.5	17200	1067756	800	1-1/2-6x6.5	2.98	7.31	2.06	4.75	5.19	2.11	2.41	4.29	1-3/8, 1-1/2, 1-3/4	13-1/2, 17, 25	-	-
25.3	29000	1067764	1100	2-4.5x6.5	2.98	7.31	2.06	4.75	5.19	2.11	2.41	4.29	1-3/8, 1-1/2, 1-3/4	13-1/2, 17, 25	-	-

\*Ultimate Load is 5 times the Working Load Limit.

## HR-1200M Metric Side Pull Hoist Rings

Weight Each (kg)	Working Load Limit (kg)*	HR-1200M Stock No.	Hoist Ring Bolt Torque (Nm)	Bolt Size A	Eff. Thread Proj. (mm) B	Dimensions (mm)							Recommended Shackles			
						C	D	E	F	G	H	I	Red Pin® Shackles 209,210,213, 215,2130,2150		Red Pin Web Shackles S-281	
													Nominal Size (in)	WLL (t)	Web Size (in)	WLL (t)
.18	300	1067803	10	M8x1.25x40	16.9	49.0	18.3	25.4	39.6	20.3	21.6	36.3	1/2, 5/8	2, 3-1/4	2	3-1/4
.18	400	1067807	16	M10x1.50x40	16.9	49.0	18.3	25.4	39.6	20.3	21.6	36.3	1/2, 5/8	2, 3-1/4	2	3-1/4
.63	1000	1067811	38	M12x1.75x50	17.2	75.4	24.6	50.8	54.1	23.6	27.2	45.5	5/8, 3/4	3-1/4, 4-3/4	2, 1.5	3-1/4, 4-1/2
.68	1400	1067815	81	M16x2.0x60	27.2	75.4	24.6	50.8	54.1	23.6	27.2	45.5	5/8, 3/4	3-1/4, 4-3/4	2, 1.5	3-1/4, 4-1/2
2.0	2250	1067823	136	M20x2.5x75	28.1	110	34.0	76.2	76.2	27.2	34.4	61.5	7/8	6-1/2	2	6-1/4
2.2	3500	1067827	312	M24x3.0x80	33.1	110	34.0	76.2	76.2	27.2	34.4	61.5	7/8	6-1/2	2	6-1/4
4.5	6250	1067831	637	M30x3.5x120	65.1	142	39.9	95.3	99.3	37.3	48.8	86.9	1, 1-1/8, 1-1/4	8-1/2, 9-1/2, 12	3	8-1/2
10.4	7750	1067835	1005	M36x4.0x150	60.6	186	52.3	121	132	53.6	61.2	109	1-3/8, 1-1/2, 1-3/4	13-1/2, 17, 25	-	-
10.7	10000	1067839	1005	M42x4.5x160	70.6	186	52.3	121	132	53.6	61.2	109	1-3/8, 1-1/2, 1-3/4	13-1/2, 17, 25	-	-
11.0	13000	1067843	1350	M48x5.0x160	70.6	186	52.3	121	132	53.6	61.2	109	1-3/8, 1-1/2, 1-3/4	13-1/2, 17, 25	-	-

\*Ultimate Load is 5 times the Working Load Limit.

# Crosby Rig Safe, Rig Smart Truck



## On-site safe rigging training

The Crosby Rig Safe, Rig Smart Truck brings safe, effective rigging training to your job site. Crosby trainers deliver 30–45 minute toolbox talks followed by live load cell and product load test presentations.

**Rig Safe. Rig Smart. Rig Crosby.**

Learn more at [rigcrosby.com](http://rigcrosby.com)

 #rigcrosby

# Crosby<sup>®</sup>





# Crosby SL-150 Slide-Loc™

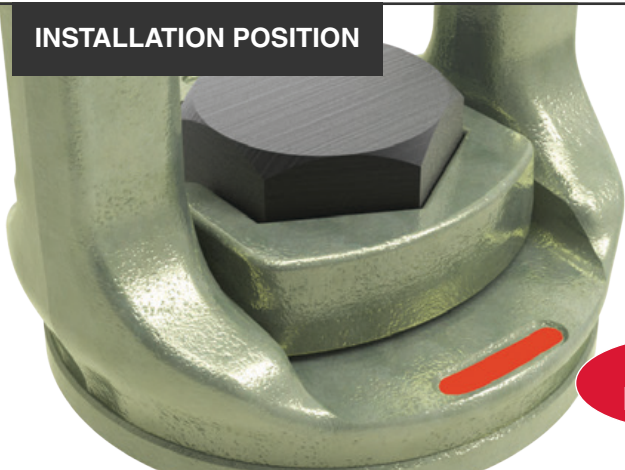

INSTALLATION POSITION

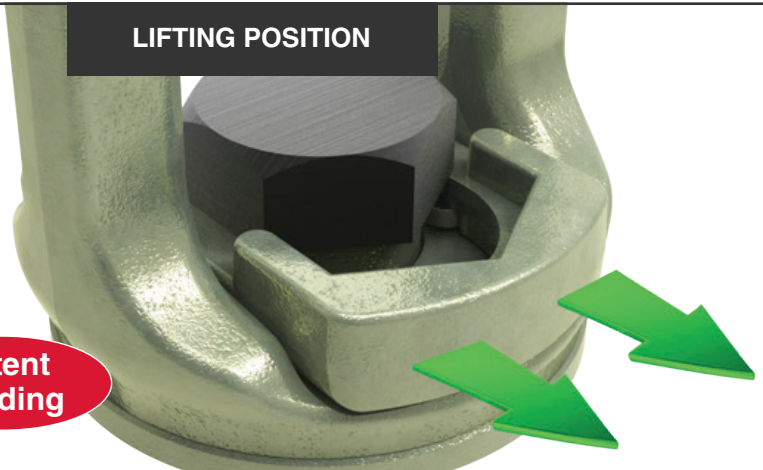

LIFTING POSITION

Patent Pending

The visible red QUIC-CHECK® mark indicates that the Crosby Slide-Loc™ is ready for installation but not for lifting.



When the red QUIC-CHECK® mark is under the slide, the Crosby Slide-Loc™ is ready for lifting.

## CROSBY'S INNOVATIVE ALTERNATIVE TO STANDARD EYE BOLTS

The new Crosby SL-150 Slide-Loc™ provides features not found on standard lifting eye bolts. At the center of the new design is the **patent pending locking mechanism** that slides to lock the bolt for faster installation, then slides back to make ready for lifting — *without the need for tools*.

- When compared to respective size eye bolts, the Crosby SL-150 Slide-Loc™:
  - Has a larger eye opening for easy access.
  - Utilizes a bail that swivels 360° to keep load aligned with the sling leg, and maintains full WLL at any angle.
- Fatigue Rated® to 20,000 cycles at 1-1/2 times the WLL.
- The patent pending locking mechanism provides quicker installation, without the need for tools.
- QUIC-CHECK® mark indicates if the Crosby SL-150 Slide-Loc™ is ready for the lift.
- Forged alloy steel and Quenched and Tempered bail provides toughness in potentially abusive field conditions.
- Meets the Machinery Directive 2006/42/EC guidelines and is marked with CE accordingly.

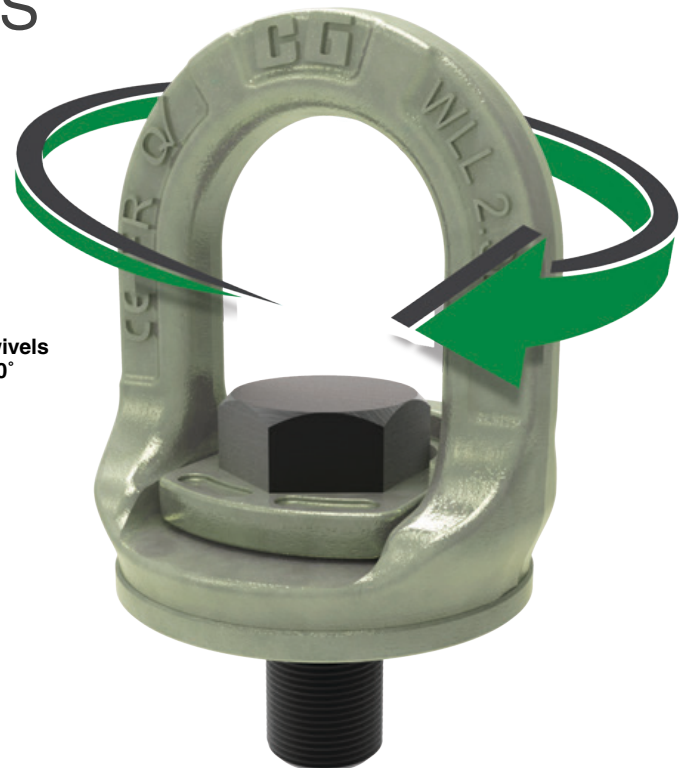

Swivels 360°



# Lifting Points



**SL-150**  
Slide-Loc  
Lifting Point

- Available in capacities from .5 to 3.2 metric tons.
- Bail is Forged Alloy Steel – Quenched and Tempered.
- Bail swivels 360° degrees.
- Rated at 100% for 90 degree angle.
- Fatigue rated to 20,000 cycles at 1-1/2 times the Working Load Limit.
- Meets the Machinery Directive 2006/42/EC guidelines and is marked with CE accordingly.
- Bolt specification for metric bolt is Grade 10.9 alloy cap screw to SO 898-1.
- Unique locking mechanism makes the lifting point well suited for quick attachment to load surface. No need for tools.
- Features **QUIC-CHECK®** markings on bail to assist in knowing when device is ready for lifting.

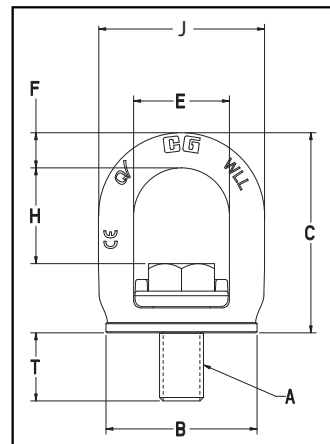

## SL-150 UNC SLIDE-LOC™ LIFT POINT

Weight Each (lb)	SL-150 Stock No.	Working Load Limit (t)*	Dimensions (in)							Effective Thread Projection Length
			Bolt Size A	B	C	E	F	H	J	T
0.30	1068407	0.50	3/8 - 16 x 1	1.40	2.09	1.10	0.33	1.11	1.77	0.60
0.53	1068416	0.75	1/2 - 13 x 1 - 1/4	1.67	2.47	1.30	0.41	1.30	2.13	0.79
1.10	1068425	1.50	5/8 - 11 x 1 - 5/8	2.17	2.98	1.46	0.52	1.46	2.50	1.01
2.05	1068434	2.30	3/4 - 10 x 2	2.71	3.59	1.72	0.63	1.72	2.98	1.26
2.16	1068443	2.30	7/8 - 9 x 2	2.71	3.61	1.72	0.63	1.72	2.98	1.23
3.73	1068452	3.20	1 - 8 x 2 - 1/2	3.25	4.33	2.08	0.76	1.93	3.59	1.59

\*Ultimate load is 4 times the Working Load Limit.

## SL-150 METRIC SLIDE-LOC™ LIFT POINT

Weight Each (kg)	SL-150M Stock No.	Working Load Limit (t)*	Dimensions (mm)							Effective Thread Projection Length
			Bolt Size A	B	C	E	F	H	J	T
.14	1068515	0.50	M10X1.5 X 25	35.5	53.0	28.0	8.5	27.8	45.0	14.6
.23	1068524	0.75	M12x1.75x30	42.5	62.6	33.0	10.5	32.9	54.0	18.3
.50	1068533	1.50	M16x2x40	55.0	75.7	37.0	13.2	37.0	63.4	24.5
.94	1068542	2.30	M20x2.5x50	68.8	91.1	43.9	16.0	43.6	75.6	31.0
1.60	1068551	3.20	M24x3x60	82.5	110.0	52.8	19.2	52.8	91.2	37.0

\*Ultimate load is 4 times the Working Load Limit.



**S-265**  
Weld-On Pivot Link



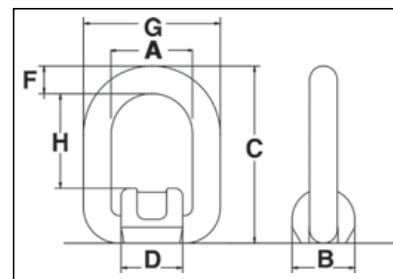



- Forged Steel — Quenched and Tempered.
- Excellent welding qualities.
- Widely used on farm machinery, trucks, steel hulled marine vessels and material handling equipment.
- Reference American Welding Society specifications for proper welding procedures.



## S-265 Weld-On Pivot Link

Working Load Limit (t)			S-265 Stock No	Weight Each (lb)	Dimensions (in)							Minimum Fillet Weld Size (in)
Design Factor 5:1	Design Factor 4:1				A	B	C	D	F	G	H	
1	1.2		1290740	.88	1.57	1.42	3.27	1.38	.51	2.60	1.65	3/32
2.5	3.2		1290768	1.32	1.77	1.73	3.90	1.65	.71	3.19	1.89	3/32
4.2	5.3		1290786	2.65	2.17	2.38	4.84	1.93	.87	3.90	2.24	1/4
6.4	8		1290802	5.29	2.76	2.52	5.67	2.52	1.02	4.80	2.64	1/4
12	15		1290820	13.01	3.82	3.54	7.60	3.39	1.34	6.50	3.70	5/16

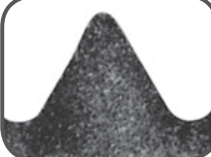

<p><b>HG-223</b></p> <p><b>HOOK &amp; HOOK</b> Meets the performance requirements of Federal Specifications FF- 791b, Type 1, Form 1, Class 5, and ASTM F-1145, except for those provisions required of the contractor.</p> 	<p><b>HG-225</b></p> <p><b>HOOK &amp; EYE</b> Meets the performance requirements of Federal Specifications FF- 791b, Type 1, Form 1, Class 6, and ASTM F-1145, except for those provisions required of the contractor.</p> 	<p><b>HG-226</b></p> <p><b>EYE &amp; EYE</b> Meets the performance requirements of Federal Specifications FF- 791b, Type 1, Form 1, Class 4, and ASTM F-1145, except for those provisions required of the contractor.</p> 
<p><b>HG-227</b></p> <p><b>JAW &amp; EYE</b> Meets the performance requirements of Federal Specifications FF- 791b, Type 1, Form 1, Class 8, and ASTM F-1145, except for those provisions required of the contractor.</p> 	<p><b>HG-228</b></p> <p><b>JAW &amp; JAW</b> Meets the performance requirements of Federal Specifications FF- 791b, Type 1, Form 1, Class 7, and ASTM F-1145, except for those provisions required of the contractor.</p> 	 <p><b>Modified Thread</b> Note stress relieving radii in this unretouched photo enlargement of the supabuckle.</p>  <p><b>Standard Thread:</b> Note stress building sharp "V" in this untouched photo enlargement.</p>



## Turnbuckle Information

- Turnbuckle assembly combinations include: Eye and Eye, Hook and Hook, Hook and Eye, Jaw and Jaw & Jaw and Eye.
- End fittings are Quenched and Tempered or Normalized, bodies heat treated by normalizing.
- Crosby's Quenched and Tempered end fittings and normalized bodies ave enhanced impact properties for greater toughness at all temperatures.
- Hot Dip galvanized.
- Hooks are forged with a greater cross sectional area that results in a stronger hook with better fatigue properties.
- Modified UNJ thread on end fittings for improved fatigue properties. Body has UNC thread
- Turnbuckle eyes are forged elongated, by design, to maximize easy attachment in system and minimize stress in the eye. For turnbuckle sizes 1/4" through 2-1/2", a shackle one size smaller can be reeved through eye.
- Forged jaw ends are fitted with bolts and nuts on size 1/4" - 5/8", and pins and cotter on sizes 3/4" through 2-3/4"
- **TURNBUCKLES RECOMMENDED FOR STRAIGHT OR IN-LINE PULL ONLY.**
- Lock Nuts available for all sizes.
- Typical hardness levels, tensile strengths and ductility properties are available for all sizes.
- Turnbuckles can be furnished proof tested or magnaflux inspected with certificates if requested at time of ord .
- Meets or exceeds all the requirements of ASME B30.26 including identification, ductilit , design factor, proof load and temperature requirements. Importantly, these turnbuckles meet other critical performance requirements, including fatigue life, impact properties and material traceability, not addressed by ASME B30.26.

# Hook & Hook Turnbuckles



**HG -223**  
Hook & Hook

- End fittings are Quenched and Tempered or Normalized, bodies heat treated by normalizing.
- Hot Dip galvanized steel.
- Hooks are forged with a greater cross sectional area that results in a stronger hook with better fatigue properties.
- **TURNBUCKLES RECOMMENDED FOR STRAIGHT OR IN-LINE PULL ONLY.**
- Modified UNJ thread on end fittings for improved fatigue properties
- Body has UNC threads.
- Lock Nuts available for all sizes (see page 198).
- Comprehensive end fitting data provided on page 194.
- Fatigue Rated.
- Meets or exceeds all requirements of ASME B30.26 including identification, ductility, design factor, proof load and temperature requirements. Importantly, these turnbuckles meet other critical performance requirements including fatigue life, impact properties and material traceability, not addressed by ASME B30.26.

Meets the performance requirements of Federal Specifications FF-791b, Type 1 Form 1 - CLASS 5, and ASTM F-1145, except for those provisions required of the contractor. For additional information, see page 452.

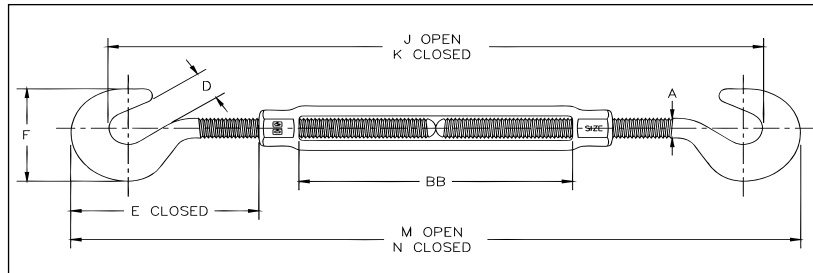

## HG-223 Hook & Hook

Thread Dia. & Take Up (in)	HG-223 Stock No.	Working Load Limit (lb)*	Weight Each (lb)	Dimensions (in)								
				A	D	E Closed	F	J Open	K Closed	M Open	N Closed	BB
† 1/4 x 4	1030011	400	.33	.25	.44	1.67	1.27	9.79	7.38	12.20	8.20	4.07
† 5/16 x 4-1/2	1030039	700	.52	.31	.50	2.00	1.50	11.58	8.58	14.08	9.58	4.58
† 3/8 x 6	1030057	1000	.83	.38	.56	2.28	1.77	15.23	10.62	17.84	11.84	6.10
1/2 x 6	1030075	1500	1.88	.50	.65	3.53	2.28	17.98	13.20	20.76	14.76	6.03
1/2 x 12	1030119	1500	2.77	.50	.65	3.51	2.28	30.27	19.49	33.05	21.05	12.36
5/8 x 6	1030137	2250	3.21	.63	.90	4.24	2.81	19.50	14.50	22.50	16.50	6.03
5/8 x 12	1030173	2250	4.58	.63	.90	4.23	2.81	31.84	20.84	34.84	22.84	12.39
3/4 x 6	1030191	3000	4.20	.75	.98	5.07	3.33	21.19	15.98	24.40	18.40	6.13
3/4 x 12	1030235	3000	6.92	.75	.98	5.04	3.33	33.59	22.38	36.80	24.80	12.59
3/4 x 18	1030253	3000	8.65	.75	.98	5.07	3.33	45.59	28.38	48.80	30.80	18.53
7/8 x 12	1030271	4000	9.85	.88	1.13	5.82	3.78	34.89	23.52	38.26	26.26	12.16
1 x 12	1030333	5000	14.8	1.00	1.25	6.56	4.25	36.59	25.06	40.12	28.12	12.18

\*Proof Load is 2.5 times the Working Load Limit. Ultimate Load is 5 times the Working Load Limit. † Mechanical Galvanized

Rigging Accessories



**HG -225**  
Hook & Eye

Meets the performance requirements of Federal Specifications FF-791b, Type 1 Form 1 - CLASS 6, and ASTM F-1145, except for those provisions required of the contractor. For additional information, see page 452.

- End fittings are Quenched and Tempered or Normalized, bodies heat treated by normalizing.
- Hot Dip galvanized steel.
- Turnbuckle eyes are forged elongated, by design, to maximize easy attachment in system and minimize stress in the eye. For turnbuckles sizes 1/4" through 1", a shackle one size smaller can be reeved through eye.
- Turnbuckle hooks are forged with a greater cross sectional area that results in a stronger hook with better fatigue properties.
- **TURNBUCKLES RECOMMENDED FOR STRAIGHT OR IN-LINE PULL ONLY.**
- Modified UNJ thread on end fittings for improved fatigue properties
- Body has UNC threads.
- Lock Nuts available for all sizes (see page 198).
- Comprehensive end fitting data provided on pages 194 & 195.
- Fatigue Rated.
- Meets or exceeds all requirements of ASME B30.26 including identification, ductility, design factor, proof load and temperature requirements. Importantly, these turnbuckles meet other critical performance requirements including fatigue life, impact properties and material traceability, not addressed by ASME B30.26.

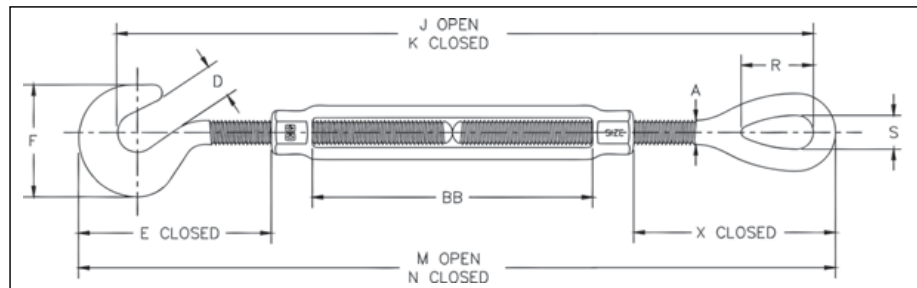

## HG-225 Hook & Eye

Thread Dia. & Take Up (in)	HG-225 Stock No.	Working Load Limit (lb)*	Weight Each (lb)	Dimensions (in)											
				A	D	E Closed	F	J Open	K Closed	M Open	N Closed	R	S	X Closed	BB
† 1/4 x 4	1030636	400	.31	.25	.44	1.67	1.27	11.66	7.66	12.29	8.29	.81	.34	1.76	4.07
† 5/16 x 4-1/2	1030654	700	.50	.31	.50	2.00	1.50	13.50	9.00	14.28	9.78	.95	.44	2.20	4.58
† 3/8 x 6	1030672	1000	.79	.38	.56	2.28	1.76	17.09	11.09	18.04	12.04	1.13	.53	2.48	6.10
1/2 x 6	1030690	1500	1.80	.50	.65	3.53	2.28	19.57	13.57	20.79	14.79	1.41	.71	3.56	6.03
1/2 x 12	1030734	1500	2.70	.50	.65	3.51	2.28	31.86	19.86	33.08	21.08	1.41	.71	3.54	12.36
5/8 x 6	1030752	2250	2.98	.63	.90	4.24	2.81	21.11	15.11	22.61	16.61	1.80	.88	4.35	6.03
5/8 x 12	1030798	2250	4.35	.63	.90	4.23	2.81	33.45	21.45	34.95	22.95	1.80	.88	4.34	12.39
3/4 x 6	1030814	3000	4.21	.75	.98	5.07	3.33	22.61	16.61	24.45	18.45	2.09	1.00	5.12	6.13
3/4 x 12	1030850	3000	6.52	.75	.98	5.04	3.33	35.01	23.01	36.85	24.85	2.09	1.00	5.09	12.59
3/4 x 18	1030878	3000	8.24	.75	.98	5.07	3.33	47.01	29.01	48.85	30.85	2.09	1.00	5.12	18.53
7/8 x 12	1030896	4000	9.34	.88	1.13	5.82	3.78	36.11	24.11	38.23	26.23	2.38	1.25	5.79	12.16
1 x 12	1030958	5000	13.9	1.00	1.25	6.56	4.25	37.65	25.65	40.06	28.06	3.00	1.43	6.50	12.18

\*Proof Load is 2.5 times the Working Load Limit. Ultimate Load is 5 times the Working Load Limit. † Mechanical Galvanized

# Eye & Eye Turnbuckles



**HG -226**  
Eye & Eye

Meets the performance requirements of Federal Specifications FF- -791b, Type 1 Form 1 - CLASS 4, and ASTM F-1145, except for those provisions required of the contractor. For additional information, see page 452.

- End fittings are Quenched and Tempered or Normalized, bodies heat treated by normalizing.
- Hot Dip galvanized steel.
- Turnbuckle eyes are forged elongated, by design, to maximize easy attachment in system and minimize stress in the eye. For turnbuckle sizes 1/4" through 2-1/2", a shackle one size smaller can be reeved through eye.
- Modified UNJ thread on end fittings for improved fatigue properties. Body has UNC thread
- **TURNBUCKLES RECOMMENDED FOR STRAIGHT OR IN-LINE PULL ONLY.**
- Lock Nuts available for all sizes (see page 198).
- Comprehensive end fitting data provided on page 195.
- Fatigue Rated.
- Meets or exceeds all requirements of ASME B30.26 including identification, ductility, design factor, proof load and temperature requirements. Importantly, these turnbuckles meet other critical performance requirements including fatigue life, impact properties and material traceability, not addressed by ASME B30.26.

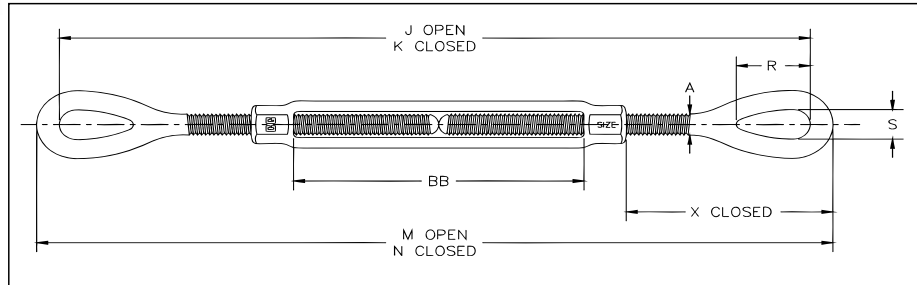

## HG-226 Eye & Eye

Thread Dia. & Take Up (in)	HG-226 Stock No.	Working Load Limit (lb)*	Weight Each (lb)	Dimensions (in)								
				A	J Open	K Closed	M Open	N Closed	R	S	X Closed	BB
† 1/4 x 4	1031252	500	.29	.25	11.94	7.94	12.38	8.38	.81	.34	1.76	4.07
† 5/16 x 4-1/2	1031270	800	.48	.31	13.92	9.42	14.48	9.98	.95	.44	2.20	4.58
† 3/8 x 6	1031298	1200	.75	.38	17.56	11.56	18.24	12.24	1.13	.53	2.48	6.10
1/2 x 6	1031314	2200	1.72	.50	19.94	13.94	20.82	14.82	1.41	.71	3.56	6.03
1/2 x 12	1031350	2200	2.63	.50	32.23	20.23	33.11	21.11	1.41	.71	3.54	12.36
5/8 x 6	1031378	3500	2.75	.63	21.72	15.72	22.72	16.72	1.80	.88	4.35	6.03
5/8 x 12	1031412	3500	4.12	.63	34.06	22.06	35.06	23.06	1.80	.88	4.34	12.39
3/4 x 6	1031430	5200	4.22	.75	23.24	17.24	24.50	18.50	2.09	1.00	5.12	6.13
3/4 x 12	1031476	5200	6.12	.75	35.64	23.64	36.90	24.90	2.09	1.00	5.09	12.59
3/4 x 18	1031494	5200	7.83	.75	47.64	29.64	48.90	30.90	2.09	1.00	5.12	18.53
7/8 x 12	1031519	7200	8.83	.88	36.70	24.70	38.20	26.20	2.38	1.25	5.79	12.16
7/8 x 18	1031537	7200	11.5	.88	49.17	31.17	50.67	32.67	2.38	1.25	5.79	18.63
1 x 6	1031555	10000	9.62	1.00	26.24	20.24	28.00	22.00	3.00	1.43	6.50	6.18
1 x 12	1031573	10000	13.0	1.00	38.24	26.24	40.00	28.00	3.00	1.43	6.50	12.18
1 x 18	1031591	10000	16.3	1.00	50.24	32.24	52.00	34.00	3.00	1.43	6.50	18.18
1 x 24	1031617	10000	20.2	1.00	62.84	38.84	64.60	40.60	3.00	1.43	6.47	24.84
1-1/4 x 12	1031635	15200	19.9	1.25	42.14	30.14	44.38	32.38	3.59	1.82	8.49	12.06
1-1/4 x 18	1031653	15200	23.8	1.25	54.14	36.14	56.38	38.38	3.59	1.82	8.49	18.06
1-1/4 x 24	1031671	15200	27.8	1.25	66.70	42.70	68.94	44.94	3.59	1.82	8.49	24.62
1-1/2 x 12	1031699	21400	28.7	1.50	44.24	32.24	46.74	34.74	4.09	2.12	9.46	12.32
1-1/2 x 18	1031715	21400	34.1	1.50	56.24	38.24	58.74	40.74	4.09	2.12	9.46	18.32
1-1/2 x 24	1031733	21400	39.6	1.50	68.86	44.86	71.36	47.36	4.09	2.12	9.46	24.94
1-3/4 x 18	1031779	28000	50.7	1.75	57.38	39.38	60.38	42.38	4.65	2.38	9.97	18.37
1-3/4 x 24	1031797	28000	58.2	1.75	69.38	45.38	72.38	48.38	4.65	2.38	9.97	24.37
2 x 24	1031813	37000	83.5	2.00	75.68	51.68	79.18	55.18	5.81	2.69	13.03	24.48
2-1/2 x 24	1031831	60000	149	2.50	79.18	55.18	83.18	59.18	6.49	3.12	13.76	24.60
2-3/4 x 24	1031859	75000	174	2.75	81.34	57.34	85.84	61.84	7.00	3.25	15.09	24.65

\*Proof Load is 2.5 times the Working Load Limit. Ultimate Load is 5 times the Working Load Limit. † Mechanical Galvanized

Rigging Accessories





**HG-227**  
Jaw & Eye

- End fittings are Quenched and Tempered or Normalized, bodies heat treated by normalizing.
- Hot Dip galvanized steel.
- Turnbuckles eyes are forged and elongated, by design, to maximize easy attachment in system and minimize stress in the eye. For turnbuckles size 1/4" through 2-1/2", a shackle one size smaller can be reeved through eye.
- Forged jaw ends are fitted with bolts and nuts for 1/4" through 5/8", and pins and cotters on 3/4" through 2-3/4" sizes.
- Modified UNJ thread on end fittings for improved fatigue properties
- Body has UNC threads.
- **TURNBUCKLES RECOMMENDED FOR STRAIGHT OR IN-LINE PULL ONLY.**
- Lock Nuts available for all sizes (see page 198).
- Comprehensive End fitting data on pages 195 & 196
- Fatigue Rated.
- Meets or exceeds all requirements of ASME B30.26 including identification, ductility, design factor, proof load and temperature requirements. Importantly, these turnbuckles meet other critical performance requirements including fatigue life, impact properties and material traceability, not addressed by ASME B30.26.

Meets the performance requirements of Federal Specifications FF-791b, Type 1 Form 1 - CLASS 8, and ASTM F-1145, except for those provisions required of the contractor. For additional information, see page 452.

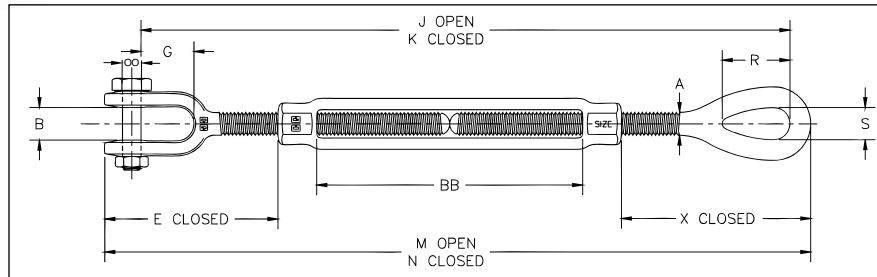

## HG-227 Jaw & Eye

Thread Dia. & Take Up (in)	HG-227 Stock No.	Working Load Limit (lb)*	Weight Each (lb)	Dimensions (in)												
				A	B	E Closed	G	J Open	K Closed	M Open	N Closed	R	S	X Closed	BB	
† 1/4 x 4	1031877	500	.33	.25	.45	1.66	.64	11.57	7.57	12.28	8.28	.81	.34	1.76	4.07	
† 5/16 x 4-1/2	1031895	800	.52	.31	.50	2.02	.87	13.50	9.00	14.30	9.80	.95	.44	2.20	4.58	
† 3/8 x 6	1031911	1200	.80	.38	.53	2.11	.85	16.91	10.91	17.87	11.87	1.13	.53	2.48	6.10	
1/2 x 6	1031939	2200	1.77	.50	.64	3.22	1.07	19.30	13.30	20.48	14.48	1.41	.71	3.56	6.03	
1/2 x 9	1031957	2200	2.25	.50	.64	3.20	1.07	25.59	16.59	26.77	17.77	1.41	.71	3.54	9.36	
1/2 x 12	1031975	2200	2.67	.50	.64	3.20	1.07	31.59	19.59	32.77	20.77	1.41	.71	3.54	12.36	
5/8 x 6	1031993	3500	2.98	.63	.79	3.90	1.32	20.73	14.73	22.27	16.27	1.80	.88	4.35	6.03	
5/8 x 9	1032019	3500	3.72	.63	.79	3.89	1.32	27.07	18.07	28.61	19.61	1.80	.88	4.34	9.39	
5/8 x 12	1032037	3500	4.35	.63	.79	3.89	1.32	33.07	21.07	34.61	22.61	1.80	.88	4.34	12.39	
3/4 x 6	1032055	5200	4.51	.75	.97	4.71	1.52	22.17	16.17	24.09	18.09	2.09	1.00	5.12	6.13	
3/4 x 9	1032073	5200	5.56	.75	.97	4.68	1.52	28.57	19.57	30.49	21.49	2.09	1.00	5.09	9.59	
3/4 x 12	1032091	5200	6.42	.75	.97	4.68	1.52	34.57	22.57	36.49	24.49	2.09	1.00	5.09	12.59	
3/4 x 18	1032117	5200	8.14	.75	.97	4.71	1.52	46.57	28.57	48.49	30.49	2.09	1.00	5.12	18.53	
7/8 x 12	1032135	7200	9.10	.88	1.16	5.50	1.77	35.68	23.68	37.91	25.91	2.38	1.25	5.79	12.16	
7/8 x 18	1032153	7200	11.6	.88	1.16	5.50	1.77	48.15	30.15	50.38	32.38	2.38	1.25	5.79	18.63	
1 x 6	1032171	10000	10.0	1.00	1.34	6.09	2.05	25.03	19.03	27.59	21.59	3.00	1.43	6.50	6.18	
1 x 12	1032199	10000	13.4	1.00	1.34	6.09	2.05	37.03	25.03	39.59	27.59	3.00	1.43	6.50	12.18	
1 x 18	1032215	10000	16.7	1.00	1.34	6.09	2.05	49.03	31.03	51.59	33.59	3.00	1.43	6.50	18.18	
1 x 24	1032233	10000	20.6	1.00	1.34	6.06	2.05	61.63	37.63	64.19	40.19	3.00	1.43	6.47	24.84	
1-1/4 x 12	1032251	15200	20.9	1.25	1.84	8.09	2.82	40.76	28.76	43.98	31.98	3.59	1.82	8.49	12.06	
1-1/4 x 18	1032279	15200	24.8	1.25	1.84	8.09	2.82	52.76	34.76	55.98	37.98	3.59	1.82	8.49	18.06	
1-1/4 x 24	1032297	15200	28.8	1.25	1.84	8.09	2.82	65.32	41.32	68.54	44.54	3.59	1.82	8.49	24.62	
1-1/2 x 12	1032313	21400	30.6	1.50	2.06	8.93	2.81	42.50	30.50	46.21	34.21	4.09	2.12	9.46	12.32	
1-1/2 x 18	1032331	21400	36.0	1.50	2.06	8.93	2.81	54.50	36.50	58.21	40.21	4.09	2.12	9.46	18.32	
1-1/2 x 24	1032359	21400	41.5	1.50	2.06	8.93	2.81	67.12	43.12	70.83	46.83	4.09	2.12	9.46	24.94	
1-3/4 x 18	1032395	28000	52.1	1.75	2.60	9.36	3.35	55.37	37.37	59.77	41.77	4.65	2.38	9.97	18.37	
1-3/4 x 24	1032411	28000	59.7	1.75	2.60	9.36	3.35	67.37	43.37	71.77	47.77	4.65	2.38	9.97	24.37	
2 x 24	1032439	37000	89.9	2.00	2.62	11.80	3.74	72.66	48.66	77.95	53.95	5.81	2.69	13.03	24.48	
2-1/2 x 24	1032457	60000	158	2.50	3.06	13.26	4.44	76.08	52.08	82.68	58.68	6.49	3.12	13.76	24.60	
2-3/4 x 24	1032475	75000	187	2.75	3.69	14.92	4.19	78.05	54.05	85.67	61.67	7.00	3.25	15.09	24.65	

\*Proof Load is 2.5 times the Working Load Limit. Ultimate Load is 5 times the Working Load Limit. † Mechanical Galvanized

# Jaw & Jaw Turnbuckles



**HG-228**  
Jaw & Jaw

Meets the performance requirements of Federal Specifications FF-791b, Type 1 Form 1 - CLASS 7, and ASTM F-1145, except for those provisions required of the contractor. For additional information, see page 452.

- End fittings are Quenched and Tempered or Normalized, bodies heat treated by normalizing.
- Hot Dip galvanized steel.
- **TURNBUCKLES RECOMMENDED FOR STRAIGHT OR IN-LINE PULL ONLY.**
- Forged jaw ends are fitted with bolts and nuts for 1/4" through 5/8", and pins and cotters on 3/4" through 2-3/4" sizes.
- Modified UNJ thread on end fittings for improved fatigue properties
- Body has UNC threads.
- Lock Nuts available for all sizes (see page 198).
- Comprehensive end fitting data provided on page 196.
- Fatigue Rated.
- Meets or exceeds all requirements of ASME B30.26 including identification, ductility, design factor, proof load and temperature requirements. Importantly, these turnbuckles meet other critical performance requirements including fatigue life, impact properties and material traceability, not addressed by ASME B30.26.

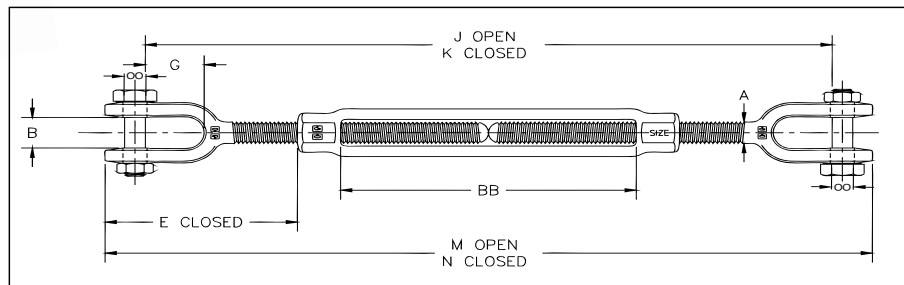

**Fatigue Rated**

Rigging  
Accessories

## HG-228 Jaw & Jaw

Thread Dia. & Take Up (in)	HG-228 Stock No.	Working Load Limit (lb)*	Weight Each (lb)	Dimensions (in)								
				A	B	E Closed	G	J Open	K Closed	M Open	N Closed	BB
† 1/4 x 4	1032493	500	.37	.25	.45	1.66	.64	11.19	7.19	12.18	8.18	4.07
† 5/16 x 4-1/2	1032518	800	.56	.31	.50	2.02	.87	13.07	8.57	14.12	9.62	4.58
† 3/8 x 6	1032536	1200	.85	.38	.53	2.11	.85	16.25	10.25	17.50	11.50	6.10
1/2 x 6	1032554	2200	1.82	.50	.64	3.22	1.07	18.65	12.65	20.14	14.14	6.03
1/2 x 9	1032572	2200	2.29	.50	.64	3.20	1.07	24.94	15.94	26.43	17.43	9.36
1/2 x 12	1032590	2200	2.71	.50	.64	3.20	1.07	30.94	18.94	32.43	20.43	12.36
5/8 x 6	1032616	3500	3.21	.63	.79	3.90	1.32	19.74	13.74	21.82	15.82	6.03
5/8 x 9	1032634	3500	3.95	.63	.79	3.89	1.32	26.08	17.08	28.16	19.16	9.39
5/8 x 12	1032652	3500	4.58	.63	.79	3.89	1.32	32.08	20.08	34.16	22.16	12.39
3/4 x 6	1032670	5200	4.80	.75	.97	4.71	1.52	21.09	15.09	23.68	17.68	6.13
3/4 x 9	1032698	5200	5.85	.75	.97	4.68	1.52	27.49	18.49	30.08	21.08	9.59
3/4 x 12	1032714	5200	6.72	.75	.97	4.68	1.52	33.49	21.49	36.08	24.08	12.59
3/4 x 18	1032732	5200	8.45	.75	.97	4.71	1.52	45.49	27.49	48.08	30.08	18.53
7/8 x 12	1032750	7200	9.37	.88	1.16	5.50	1.77	34.65	22.65	37.62	25.62	12.16
7/8 x 18	1032778	7200	11.8	.88	1.16	5.50	1.77	47.12	29.12	50.09	32.09	18.63
1 x 6	1032796	10000	10.4	1.00	1.34	6.09	2.05	23.82	17.82	27.18	21.18	6.18
1 x 12	1032812	10000	13.8	1.00	1.34	6.09	2.05	35.82	23.82	39.18	27.18	12.18
1 x 18	1032830	10000	17.1	1.00	1.34	6.09	2.05	47.82	29.82	51.18	33.18	18.18
1 x 24	1032858	10000	21.0	1.00	1.34	6.06	2.05	60.42	36.42	63.78	39.78	24.84
1-1/4 x 12	1032876	15200	21.9	1.25	1.84	8.09	2.82	39.37	27.37	43.58	31.58	12.06
1-1/4 x 18	1032894	15200	25.9	1.25	1.84	8.09	2.82	51.37	33.37	55.58	37.58	18.06
1-1/4 x 24	1032910	15200	29.8	1.25	1.84	8.09	2.82	63.37	39.37	68.14	44.14	24.62
1-1/2 x 12	1032938	21400	32.6	1.50	2.06	8.93	2.81	40.76	28.76	45.68	33.68	12.32
1-1/2 x 18	1032956	21400	38.0	1.50	2.06	8.93	2.81	52.76	34.76	57.68	39.68	18.32
1-1/2 x 24	1032974	21400	43.5	1.50	2.06	8.93	2.81	65.38	41.38	70.30	46.30	24.94
1-3/4 x 18	1033018	28000	53.5	1.75	2.60	9.36	3.35	53.35	35.35	59.16	41.16	18.37
1-3/4 x 24	1033036	28000	61.1	1.75	2.60	9.36	3.35	65.35	41.35	71.16	47.16	24.37
2 x 24	1033054	37000	96.3	2.00	2.62	11.80	3.74	69.64	45.64	76.72	52.72	24.48
2-1/2 x 24	1033072	60000	167	2.50	3.06	13.26	4.44	72.97	48.97	82.18	58.18	24.60
2-3/4 x 24	1033090	75000	199	2.75	3.69	14.92	4.19	74.75	50.75	85.50	61.50	24.65

\*Proof Load is 2.5 times the Working Load Limit. Ultimate Load is 5 times the Working Load Limit. † Mechanical Galvanized



- Quenched and Tempered or Normalized.
- Hot Dip galvanized steel.
- Hooks are forged with a greater cross sectional area that results in a stronger hook with better fatigue properties.
- Modified UNJ thread for improved fatigue properties.
- Fatigue Rated.

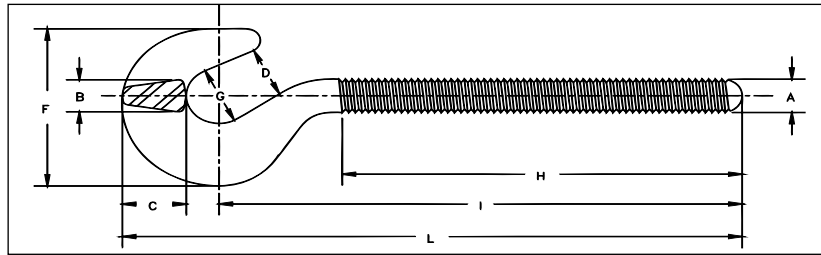

HG-4037 Hook End Fittings

Shank Dia. & Take Up (in)	RH Hook Stock No.	LH Hook Stock No.	Working Load Limit (lb)	Weight Each (lb)	Dimensions (in)								
					A	B	C	D	F	G	H	I	L
* 1/4 x 4	1070012	1070539	400	.09	.25	.25	.41	.44	1.27	.50	2.59	3.44	4.10
* 5/16 x 4-1/2	1070030	1070557	700	.15	.31	.31	.50	.50	1.50	.56	3.00	4.01	4.79
* 3/8 x 6	1070058	1070575	1000	.27	.38	.38	.61	.56	1.76	.62	3.88	5.00	5.92
1/2 x 6	1070076	1070593	1500	.59	.50	.50	.78	.65	2.28	.82	4.19	6.19	7.38
1/2 x 12	1070110	1070637	1500	.75	.50	.50	.78	.65	2.28	.82	7.19	9.19	10.38
5/8 x 6	1070138	1070655	2250	1.05	.63	.63	1.00	.90	2.81	1.00	4.44	6.75	8.25
5/8 x 12	1070174	1070691	2250	1.31	.63	.63	1.00	.84	2.81	1.00	7.44	9.75	11.25
3/4 x 6	1070192	1070717	3000	1.35	.75	.75	1.21	.98	3.33	1.13	4.56	7.43	9.20
3/4 x 12	1070236	1070753	3000	2.13	.75	.75	1.21	.98	3.33	1.13	7.56	10.43	12.20
3/4 x 18	1070254	1070771	3000	2.51	.75	.75	1.21	.98	3.33	1.13	10.56	13.43	15.20
7/8 x 12	1070272	1070799	4000	3.12	.88	.88	1.37	1.13	3.78	1.26	7.81	11.13	13.13
7/8 x 18	1070290	1070815	4000	3.62	.88	.88	1.37	1.13	3.78	1.26	10.81	14.13	16.13
1 x 6	1070316	1070833	5000	3.96	1.00	1.00	1.53	1.25	4.25	1.38	5.06	8.84	11.06
1 x 12	1070334	1070851	5000	4.72	1.00	1.00	1.53	1.25	4.25	1.38	8.06	11.84	14.06

\* Mechanical Galvanized

# Turnbuckles - Eye End Fittings



**HG -4037**  
Eye End Fitting

- Quenched and Tempered or Normalized.
- Hot Dip galvanized steel.
- Turnbuckle eyes are forged elongated, by design, to maximize easy attachment in system and minimize stress in the eye. For turnbuckle sizes 1/4" through 2-1/2", a shackle one size smaller can be reeved through eye.
- Modified UNJ thread for improved fatigue properties.
- Fatigue Rated.

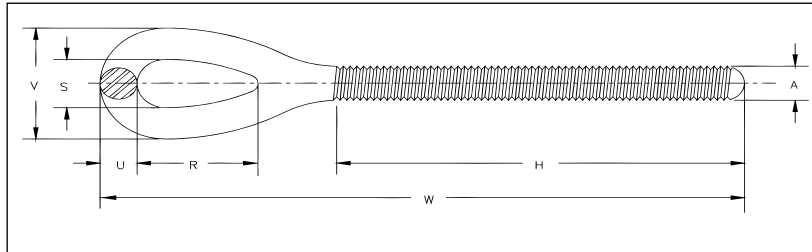

**Fatigue Rated**

Rigging  
Accessories

## HG-4037 Eye End Fittings

Shank Dia. & Take Up (in)	RH Eye Stock No.	LH Eye Stock No.	Working Load Limit (lb)	Weight Each (lb)	Dimensions (in)						
					A	H	R	S	U	V	W
* 1/4 x 4	1071057	1071672	500	.07	.25	2.59	.81	.34	.22	.78	4.19
* 5/16 x 4 1/2	1071075	1071690	800	.13	.31	3.00	.95	.44	.28	1.00	4.99
* 3/8 x 6	1071093	1071716	1200	.23	.38	3.88	1.13	.53	.34	1.21	6.12
1/2 x 6	1071119	1071734	2200	.51	.50	4.19	1.41	.71	.44	1.59	7.41
1/2 x 9	1071137	1071752	2200	.59	.50	5.69	1.41	.71	.44	1.59	8.91
1/2 x 12	1071155	1071770	2200	.68	.50	7.19	1.41	.71	.44	1.59	10.41
5/8 x 6	1071173	1071798	3500	.82	.63	4.44	1.80	.88	.50	1.88	8.36
5/8 x 9	1071191	1071814	3500	.95	.63	5.94	1.80	.88	.50	1.88	9.86
5/8 x 12	1071217	1071832	3500	1.08	.63	7.44	1.80	.88	.50	1.88	11.36
3/4 x 6	1071235	1071850	5200	1.36	.75	4.56	2.09	1.00	.63	2.26	9.25
3/4 x 9	1071253	1071878	5200	1.55	.75	6.06	2.09	1.00	.63	2.26	10.75
3/4 x 12	1071271	1071896	5200	1.73	.75	7.56	2.09	1.00	.63	2.26	12.25
3/4 x 18	1071299	1071912	5200	2.10	.75	10.56	2.09	1.00	.63	2.26	15.25
7/8 x 12	1071315	1071930	7200	2.61	.88	7.81	2.38	1.25	.75	2.75	13.10
7/8 x 18	1071333	1071958	7200	3.12	.88	10.81	2.38	1.25	.75	2.75	16.10
1 x 6	1071351	1071976	10000	3.15	1.00	5.06	3.00	1.43	.88	3.19	11.00
1 x 12	1071379	1071994	10000	3.81	1.00	8.06	3.00	1.43	.88	3.19	14.00
1 x 18	1071397	1072010	10000	4.48	1.00	11.06	3.00	1.43	.88	3.19	17.00
1 x 24	1071413	1072038	10000	5.15	1.00	14.06	3.00	1.43	.88	3.19	20.00
1-1/4 x 12	1071431	1072056	15200	7.07	1.25	8.38	3.59	1.82	1.12	4.06	16.19
1-1/4 x 18	1071459	1072074	15200	8.12	1.25	11.38	3.59	1.82	1.12	4.06	19.19
1-1/4 x 24	1071477	1072092	15200	9.16	1.25	14.38	3.59	1.82	1.12	4.06	22.19
1-1/2 x 12	1071495	1072118	21400	10.3	1.50	8.75	4.09	2.12	1.25	4.62	17.37
1-1/2 x 18	1071510	1072136	21400	11.8	1.50	11.75	4.09	2.12	1.25	4.62	20.37
1-1/2 x 24	1071538	1072154	21400	13.3	1.50	14.75	4.09	2.12	1.25	4.62	23.37
1-3/4 x 18	1071574	1072190	28000	17.5	1.75	12.16	4.65	2.38	1.50	5.38	21.19
1-3/4 x 24	1071592	1072216	28000	19.5	1.75	15.16	4.65	2.38	1.50	5.38	24.19
2 x 24	1071618	1072234	37000	28.9	2.00	15.59	5.81	2.69	1.75	6.19	27.59
2-1/2 x 24	1071636	1072252	60000	46.4	2.50	17.56	6.50	3.12	2.00	7.12	29.59
2-3/4 x 24	1071654	1072270	75000	60.2	2.75	17.69	7.00	3.25	2.25	7.75	30.92

\* Mechanical Galvanized



## Turnbuckles - Jaw End Fittings

### HG-4037 Jaw End Fittings

- Quenched and Tempered or Normalized.
- Hot dip galvanized steel.
- Forged jaw ends are fitted with bolts and nuts on sizes 1/4" through 5/8", and pins and cotters on sizes 3/4" through 2-3/4".
- Modified UNJ thread for improved fatigue properties.
- Fatigue Rated.

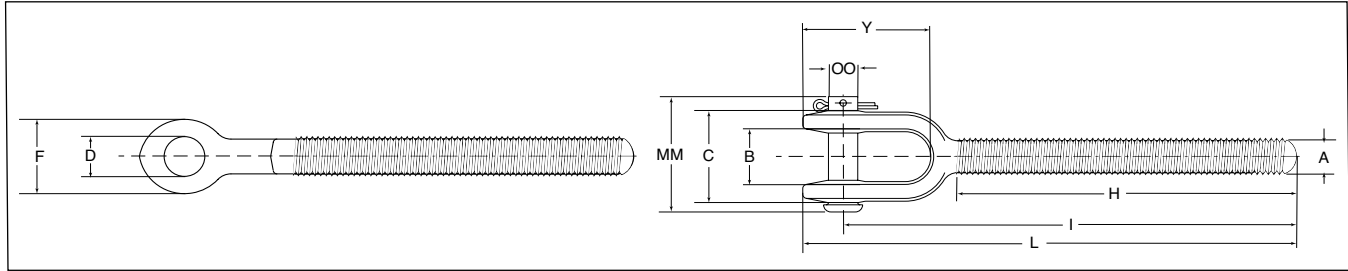

### HG-4037 Jaw End Fittings

Shank Dia. & Take Up (in)	RH Jaw Stock No.	LH Jaw Stock No.	Working Load Limit (lb)	Weight Each (lb)	Dimensions (in)										
					A	B	C	D	F	H	I Nom. Min.	L Nom. Min.	Y	MM	OO Bolt Pin
* 1/4 x 4	1072298	1072911	500	.11	.25	.45	.91	.30	.63	2.59	3.72	4.09	1.13	1.41	.25
* 5/16 x 4 1/2	1072314	1072939	800	.17	.31	.50	1.02	.30	.69	3.00	4.41	4.81	1.39	1.41	.25
* 3/8 x 6	1072332	1072957	1200	.28	.38	.53	1.15	.36	.81	3.88	5.28	5.75	1.47	1.58	.31
1/2 x 6	1072350	1072975	2200	.56	.50	.64	1.36	.42	1.00	4.19	6.51	7.07	1.81	1.87	.37
1/2 x 9	1072378	1072993	2200	.63	.50	.64	1.36	.42	1.00	5.69	8.01	8.57	1.81	1.87	.37
1/2 x 12	1072396	1073019	2200	.72	.50	.64	1.36	.42	1.00	7.19	9.51	10.07	1.81	1.87	.37
5/8 x 6	1072412	1073037	3500	1.05	.63	.79	1.75	.55	1.31	4.31	7.12	7.91	2.36	2.44	.50
5/8 x 9	1072430	1073055	3500	1.18	.63	.79	1.75	.55	1.31	5.81	8.62	9.41	2.36	2.44	.50
5/8 x 12	1072458	1073073	3500	1.31	.63	.79	1.75	.55	1.31	7.31	10.12	10.91	2.36	2.44	.50
3/4 x 6	1072476	1073091	5200	1.65	.75	.97	2.09	.69	1.63	4.56	7.86	8.84	2.81	2.56	.63
3/4 x 9	1072494	1073117	5200	1.84	.75	.97	2.09	.69	1.63	6.06	9.36	10.34	2.81	2.56	.63
3/4 x 12	1072519	1073135	5200	2.03	.75	.97	2.09	.69	1.63	7.56	10.86	11.84	2.81	2.56	.63
3/4 x 18	1072537	1073153	5200	2.41	.75	.97	2.09	.69	1.63	10.56	13.86	14.84	2.81	2.56	.63
7/8 x 12	1072555	1073171	7200	2.88	.88	1.16	2.56	.81	1.88	7.81	11.70	12.81	3.25	3.09	.75
7/8 x 18	1072573	1073199	7200	3.25	.88	1.16	2.56	.81	1.88	10.81	14.70	15.81	3.25	3.09	.75
1 x 6	1072591	1073215	10000	3.56	1.00	1.34	2.76	.94	2.12	5.06	9.35	10.59	3.73	3.44	.88
1 x 12	1072617	1073233	10000	4.22	1.00	1.34	2.76	.94	2.12	8.06	12.35	13.59	3.73	3.44	.88
1 x 18	1072635	1073251	10000	4.89	1.00	1.34	2.76	.94	2.12	11.06	15.35	16.59	3.73	3.44	.88
1 x 24	1072653	1073279	10000	5.56	1.00	1.34	2.76	.94	2.12	14.06	18.35	19.59	3.73	3.44	.88
1-1/4 x 12	1072671	1073297	15200	8.10	1.25	1.84	3.72	1.19	2.63	8.38	14.25	15.79	4.92	4.53	1.13
1-1/4 x 18	1072699	1073313	15200	9.14	1.25	1.84	3.72	1.19	2.63	11.38	17.25	18.79	4.92	4.53	1.13
1-1/4 x 24	1072715	1073331	15200	10.2	1.25	1.84	3.72	1.19	2.63	14.38	20.25	21.79	4.92	4.53	1.13
1-1/2 x 12	1072733	1073359	21400	12.3	1.50	2.06	4.16	1.47	3.12	8.75	15.07	16.84	5.27	5.13	1.38
1-1/2 x 18	1072751	1073377	21400	13.8	1.50	2.06	4.16	1.47	3.12	11.75	18.07	19.84	5.27	5.13	1.38
1-1/2 x 24	1072779	1073395	21400	15.3	1.50	2.06	4.16	1.47	3.12	14.75	21.07	22.84	5.27	5.13	1.38
1-3/4 x 18	1072813	1073439	28000	18.9	1.75	2.60	4.66	1.72	3.50	12.16	18.49	20.58	6.25	6.00	1.63
1-3/4 x 24	1072831	1073457	28000	21.0	1.75	2.60	4.66	1.72	3.50	15.16	21.49	23.58	6.25	6.00	1.63
2 x 24	1072859	1073475	37000	35.3	2.00	2.62	5.61	2.09	4.19	15.59	23.82	26.36	7.28	6.88	2.00
2-1/2 x 24	1072877	1073493	60000	55.8	2.50	3.06	5.84	2.38	5.62	17.20	25.61	29.09	9.04	7.50	2.25
2-3/4 x 24	1072895	1073518	75000	72.4	2.75	3.69	6.57	2.88	6.12	17.35	26.75	30.75	9.56	8.38	2.75

\* Mechanical Galvanized

# Turnbuckles - Body Only

## HG-2510 BODY

- Heat treat by normalizing.
- Hot Dip galvanized.
- UNC threads
- Fatigue Rated.
- Meets the performance requirements of Federal Specifications FF- -791b, Type 1, Form 1 - Class 2, except for those provisions required by the contractor.

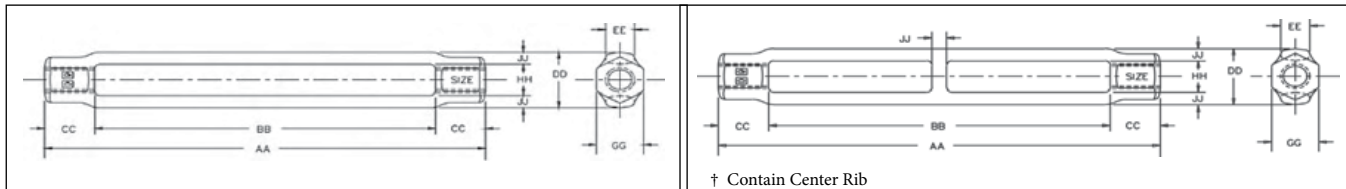

## HG-2510 Body

Shank Dia. & Take Up (in)	HG-2510 Stock No.	Working Load Limit (lb)	Weight Each (lb)	Dimensions (in)							
				AA	BB	CC	DD	EE	GG	HH	JJ
* 5/16 x 4-1/2	1033919	800	.22	5.59	4.58	.51	.82	.38	.56	.44	.19
* 3/8 x 6	1033937	1200	.29	7.29	6.10	.60	.88	.38	.63	.50	.19
1/2 x 6	1033955	2200	.70	7.70	6.03	.84	1.19	.68	.81	.63	.28
† 1/2 x 9	1033973	2200	1.03	11.03	9.36	.84	1.19	.68	.81	.63	.28
† 1/2 x 12	1033991	2200	1.27	14.03	12.36	.84	1.19	.68	.81	.63	.28
5/8 x 6	1034017	3500	1.11	8.02	6.03	1.00	1.43	.83	1.00	.75	.34
† 5/8 x 9	1034035	3500	1.59	11.38	9.39	1.00	1.43	.83	1.00	.75	.34
† 5/8 x 12	1034053	3500	1.96	14.38	12.39	1.00	1.43	.83	1.00	.75	.34
3/4 x 6	1034071	5200	1.50	8.26	6.13	1.07	1.74	.94	1.13	.94	.40
† 3/4 x 9	1034099	5200	2.17	11.72	9.59	1.07	1.74	.94	1.13	.94	.40
† 3/4 x 12	1034115	5200	2.66	14.72	12.59	1.07	1.74	.94	1.13	.94	.40
† 3/4 x 18	1034133	5200	3.63	20.66	18.53	1.07	1.74	.94	1.13	.94	.40
7/8 x 12	1034179	7200	3.61	14.62	12.16	1.23	2.00	1.13	1.31	1.06	.47
† 7/8 x 18	1034197	7200	5.27	21.09	18.63	1.23	2.00	1.13	1.31	1.06	.47
1 x 6	1034213	10000	3.32	9.00	6.18	1.41	2.45	1.25	1.50	1.25	.60
1 x 12	1034231	10000	5.34	15.00	12.18	1.41	2.45	1.25	1.50	1.25	.60
† 1 x 18	1034259	10000	7.35	21.00	18.18	1.41	2.45	1.25	1.50	1.25	.60
† 1 x 24	1034277	10000	9.85	27.66	24.84	1.41	2.45	1.25	1.50	1.25	.60
1-1/4 x 12	1034339	15200	5.72	15.40	12.06	1.67	2.62	1.25	1.88	1.50	.56
1-1/4 x 18	1034357	15200	7.58	21.40	18.06	1.67	2.62	1.25	1.88	1.50	.56
† 1-1/4 x 24	1034375	15200	9.45	27.96	24.62	1.67	2.62	1.25	1.88	1.50	.56
1-1/2 x 12	1034437	21400	8.01	15.82	12.32	1.75	2.99	1.50	2.25	1.75	.62
1-1/2 x 18	1034455	21400	10.4	21.82	18.32	1.75	2.99	1.50	2.25	1.75	.62
† 1-1/2 x 24	1034473	21400	12.9	28.45	24.94	1.75	2.99	1.50	2.25	1.75	.62
1-3/4 x 18	1034552	28000	15.7	22.44	18.37	2.04	3.62	1.75	2.62	2.12	.75
1-3/4 x 24	1034570	28000	19.2	28.44	24.37	2.04	3.62	1.75	2.62	2.12	.75
2 x 24	1034632	37000	25.8	29.13	24.48	2.33	4.14	2.00	3.00	2.38	.88
2-1/2 x 24	1034678	60000	55.9	31.66	24.60	3.53	5.62	2.75	3.88	3.12	1.25
2-3/4 x 24	1034696	75000	54.0	31.66	24.65	3.51	5.62	2.75	3.88	4.48	1.25

\* Mechanical Galvanized

† Contains Center Rib for additional body support.

Rigging Accessories

## Stub End Turnbuckles



**HS - 251**  
Stub End  
Turnbuckles

- End fittings are Quenched and Tempered or Normalized, bodies heat treated by normalizing.
- Complete assembly is self-colored.
- Reference American Welding Society Specifications for proper welding procedures
- Meets the performance requirements of Federal Specifications FF- -791b, Type 1 Form 1 - CLASS 3, and ASTM F-1145, except for those provisions required of the contractor.

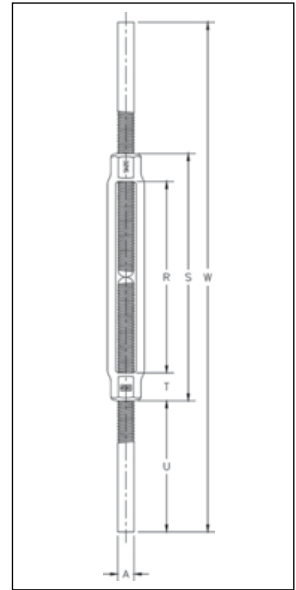

### HS-251 Stub End Turnbuckles

Thread Diameter (in)	HS-251 Stock No.	Working Load Limit (lb)	Weight Each (lb)	Dimensions (in)					
				A	R	S	T	U	W
3/8 x 6	1033143	1200	.75	.38	6.00	7.13	.56	4.44	16.00
1/2 x 6	1033161	2200	1.25	.50	6.00	7.50	.75	4.25	16.00
5/8 x 6	1033223	3500	2.11	.63	6.00	7.88	.94	4.06	16.00
3/4 x 6	1033287	5200	3.27	.75	6.00	8.25	1.13	4.38	17.00
7/8 x 6	1033367	7200	4.78	.88	6.00	8.63	1.31	4.69	18.00
1 x 6	1033429	10000	6.36	1.00	6.00	9.00	1.50	5.00	19.00
1 x 12	1033447	10000	8.80	1.00	12.00	15.00	1.50	5.00	25.00
1-1/8 x 6	1033508	12400	8.88	1.13	6.00	9.13	1.56	4.94	19.00
1-1/4 x 6	1033526	15200	10.18	1.25	6.00	9.13	1.56	5.44	20.00
1-1/4 x 12	1033544	15200	13.60	1.25	12.00	15.12	1.56	5.44	26.00
1-1/2 x 12	1033642	21400	20.44	1.50	12.00	15.75	1.88	5.38	26.50

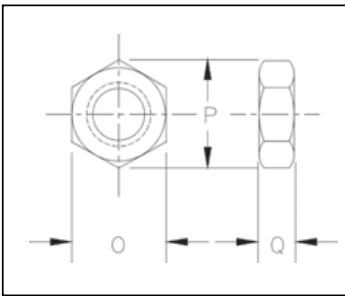

**HG -4060/  
HG -4061**  
Lock Nuts

### HG-4060 / HG-4061 Lock Nuts

Shank Dia. & Take Up (in)	Right Hand HG-4060 Stock No.	Left Hand HG-4061 Stock No.	Weight Per 100 (lb)	Dimensions (in)		
				O	P	Q
1/4	1075115	1075491	.80	.44	.50	.16
5/16	1075133	1075516	1.30	.50	.56	.19
3/8	1075151	1075534	2.00	.56	.64	.22
1/2	1075197	1075570	4.00	.75	.86	.31
5/8	1075213	1075598	7.00	.94	1.06	.38
3/4	1075231	1075614	11.00	1.13	1.26	.42
7/8	1075259	1075632	16.30	1.31	1.50	.48
1	1075277	1075650	23.80	1.50	1.69	.55
1-1/8	1075295	1075678	32.00	1.50	1.69	.55
1-1/4	1075311	1075696	62.50	1.88	2.13	.72
1-1/2	1075357	1075730	72.00	2.25	2.53	.84
1-3/4	1075393	1075776	112.00	2.75	3.18	1.00
2	1075419	1075794	150.00	3.12	3.61	1.12
2-1/2	1075455	1075838	330.00	3.88	4.47	1.50
2-3/4	1075473	1075856	425.00	4.25	4.91	1.62

**Vitalife® products are the preferred wire rope lubricants in the industry because of their ability to penetrate into wire rope and displace water and contaminants, thus reducing wear and corrosion throughout the rope.**

- Available in a variety of container sizes.
- Provides inner strand preservation and lubricity.
- Allows for easy visual inspection of the ropes.
- Reduces the friction between the strands of the wire rope, thus extending rope life.
- Adheres to surface of strands, forming an outer film which provides excellent corrosive protection
- Non-tacky (will not attract dust)
- Vitalife® in aerosol form is a regulated dangerous good. See MSDS sheet for shipping instructions.
- Vitalife® Bio-Lube has been developed especially for environmentally friendly applications.
- Vitalife® 500 has been developed exclusively for ski lifts and tramways.



Vitalife® Type	Container Size	Vitalife® Stock No.	Weight Each (kg)
Vitalife® 400 (Standard)	12 Ounce	1038946	1.00
	5 Gallon	1038955	41.0
	55 Gallon	1038964	420
Vitalife® 410 BIO-LUBE (Environmentally Friendly)	12 Ounce	1039004	1.00
	5 Gallon	1039013	41.0
	55 Gallon	1039022	420
Vitalife® 500 (Ski Lifts and Tramways)	5 Gallon	1038973	41.0
	55 Gallon	1038982	420



### VSP Vitalife® Spray Applicators

- Designed and manufactured to work in the rugged field conditions of the construction industry.
- All applicator seals are specially designed to work with Vitalife® 400 and BIO-LUBE products.

Description	VSP Stock No.	Weight Each (lb)
4 Gallon Backpack Sprayer	1039092	11.8



## FORGED EYE BOLT

### WARNINGS & APPLICATION INSTRUCTIONS



Regular Nut Eye Bolt G-291

Shoulder Nut Eye Bolt G-277

Machinery Eye Bolt S-279 / M-279

### Important Safety Information - Read & Follow

#### Inspection/Maintenance Safety:

- Always inspect eye bolt before use.
- Never use eye bolt that shows signs of wear or damage.
- Never use eye bolt if eye or shank is bent or elongated.
- Always be sure threads on shank and receiving holes are clean.
- Never machine, grind, or cut eye bolt.
- Do not leave threaded end of machinery eye bolt in aluminum loads for long periods of time as it may cause corrosion.

#### Assembly Safety:

- Never exceed load limits specified in Table 1 & Table 2.
- Never use regular nut eye bolts for angular lifts.
- Always use shoulder nut eye bolts (or machinery eye bolts) for angular lifts.
- For angular lifts, adjust working load as follows:

ANGLE FROM "IN-LINE"	ADJUSTED WORKING LOAD LIMIT
5 degrees	100% of rated working load
15 degrees	80% of rated working load
30 degrees	65% of rated working load
45 degrees	30% of rated working load
90 degrees	25% of rated working load

- Never undercut eye bolt to seat shoulder against the load.
- Always countersink receiving hole or use washers with sufficient I.D. to seat shoulder.
- Always screw eye bolt down completely for proper seating.
- Always tighten nuts securely against the load.

Size (in)	Working Load Limit (lb)
1/4	650
5/16	1,200
3/8	1,550
1/2	2,600
5/8	5,200
3/4	7,200
7/8	10,600
1	13,300
1-1/8	15,000
1-1/4	21,000
1-1/2	24,000
1-3/4	34,000
2	42,000
2-1/2	65,000

**⚠ WARNING**

- Load may slip or fall if proper eye bolt assembly and lifting procedures are not used.
- A falling load can seriously injure or kill.
- Read and understand these instructions, and follow all eye bolt safety information presented here.
- Read, understand, and follow information in diagrams and charts below before using eye bolt assemblies.

### Shoulder Nut Eye Bolt – Installation for Angular Loading

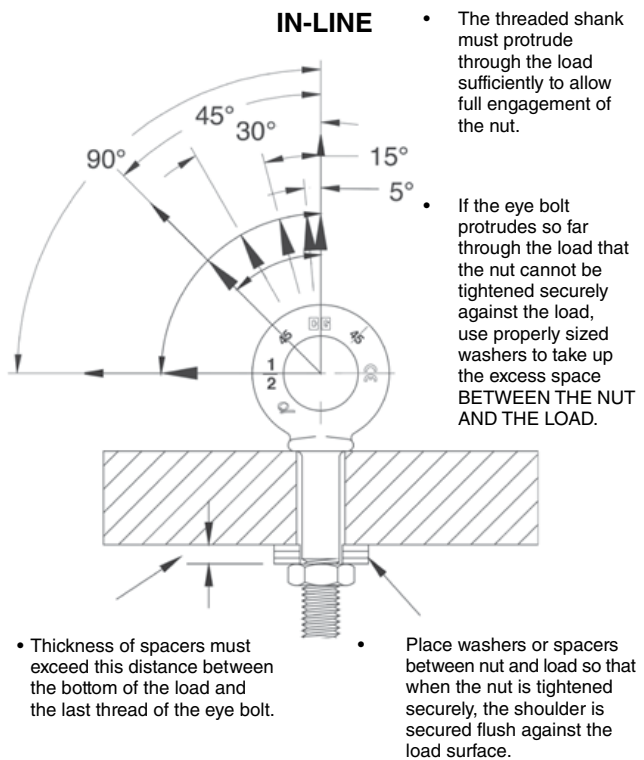
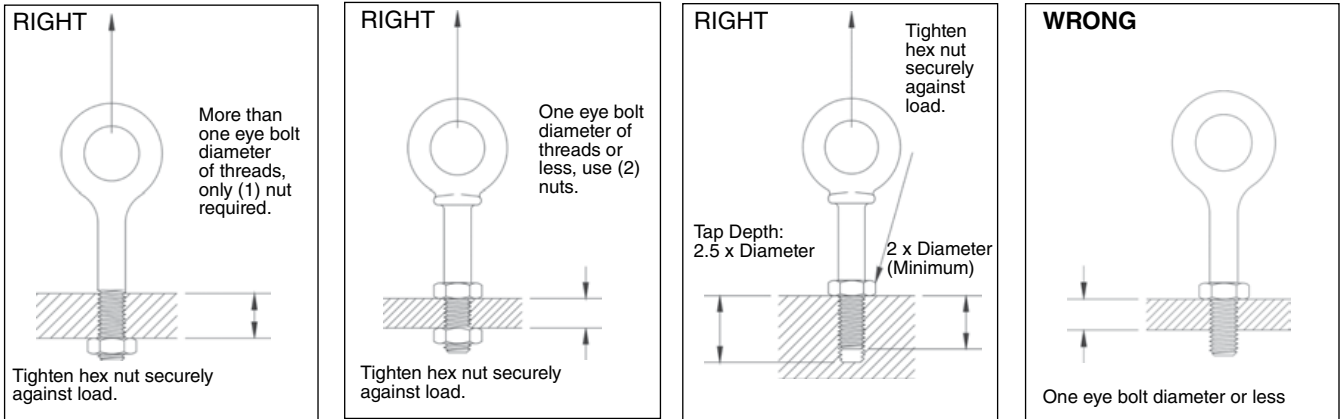

Figure 1

Metric Size	Working Load Limit - kg
m6	200
m8	400
m10	640
m12	1000
m16	1800
m20	2500
m24	4000
m27	5000
m30	6000
m36	8500
m42	14000
m48	17300
m64	29500

## Important – Read and understand these instructions before using eye bolts. Regular Nut & Shoulder Nut Eye Bolt – Installation for In-Line Loading



### Operating Safety

- Always stand clear of load.
- Always lift load with steady, even pull – do not jerk.
- Always apply load to eye bolt in the plane of the eye – not at an angle.
- Never exceed the capacity of the eye bolt—see Table 1 & 2.
- When using lifting slings of two or more legs, make sure the loads in the legs are calculated using the angle from the vertical sling angle to the leg and properly size the shoulder nut or machinery eye bolt for the angular load.

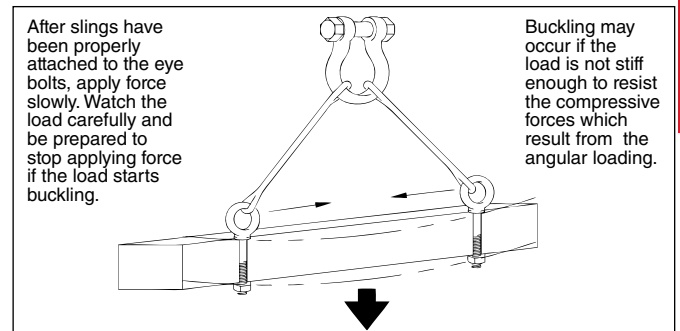
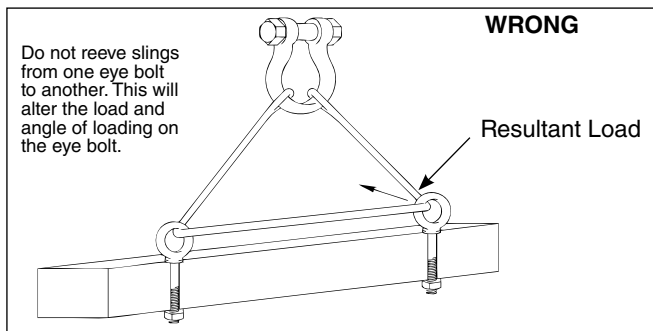

Rigging Accessories

## Machinery Eye Bolt - Installation for In-Line & Angular Loading

These eye bolts are primarily intended to be installed into tapped holes.

1. After the loads on the eye bolts have been calculated, select the proper size eye bolt for the job.

For angular lifts, adjust working load as follows:

Direction of Pull (from In-Line)	Adjusted Working Load
45 degrees	30% of rated working load
90 degrees	25% of rated working load

2. Drill and tap the load to the correct sizes to a minimum depth of one-half the eye bolt size beyond the shank length of the machinery eye bolt.
3. Thread the eye bolt into the load until the shoulder is flush and securely tightened against the load.
4. If the plane of the machinery eye bolt is not aligned with the sling line, estimate the amount of unthreading rotation necessary to align the plane of the eye properly.
5. Remove the machinery eye bolt from the load and add shims (washers) of proper thickness to adjust the angle of the plane of the eye to match the sling line. Use Table 3 to estimate the required shim thickness for the amount of unthreading rotation required.

Eye Bolt Size (in)	Shim Thickness Required to Change Rotation 90° (in)	Eye Bolt Size (mm)	Shim Thickness Required to change Rotation 90° (mm)
1/4	.0125	M6	.25
5/16	.0139	M8	.31
3/8	.0156	M10	.38
1/2	.0192	M12	.44
5/8	.0227	M16	.50
3/4	.0250	M20	.62
7/8	.0278	M24	.75
1	.0312	M27	.75
1-1/8	.0357	M30	.88
1-1/4	.0357	M36	1.00
1-1/2	.0417	M42	1.13
1-3/4	.0500	M48	1.25
2	.0556	M64	1.50
2-1/2	.0625	—	—

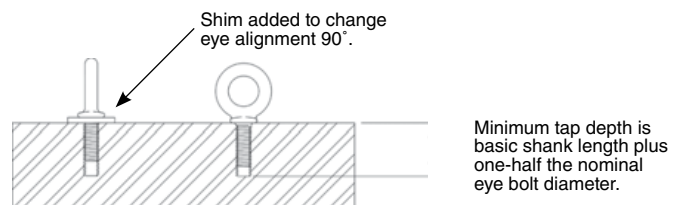

**CROSBY® PIVOT HOIST RING**

**WARNINGS & APPLICATION INSTRUCTIONS**



**HR-100**

**Pivot Hoist Ring  
Application / Assembly Instructions**

- Use pivot hoist ring only with ferrous metal (steel, iron) workpiece. Do not leave threaded end of hoist ring in aluminium for long periods of time due to corrosion.
- After determining the loads on each pivot hoist ring, select the proper size using the Working Load Limit (WLL) ratings in Table 1 for UNC threads.
- Drill and tap the workpiece to the correct size to a minimum depth of one-half the threaded bolt diameter plus the effective thread projection length (see Table 1, on next page). To select proper bolt and thread sizes see Table 1 on next page.
- Install the pivot hoist ring to recommended torque with a torque wrench making sure the pivot hoist ring body meets the load (workpiece) surface. See rated load limit and bolt torque requirements imprinted on top of the pivot hoist ring body (see Table 1, on next page).
- Never use spacers between the pivot hoist ring body and workpiece surface.
- Always select proper load rated lifting device for use with pivot hoist ring.
- Attach lifting device ensuring free fit to pivot hoist ring bail (lifting ring) (Figure 1).
- Apply partial load and check proper pivot. Ensure load alignment is in the direction of pivot (Figure 4). There should be no interference between load (workpiece) and pivot hoist ring bail (Figure 2).

**⚠ WARNING**

- Load may slip or fall if proper Hoist Ring assembly and lifting procedures are not used.
- A falling load can seriously injure or kill.
- Do not use with damaged slings or chain. For inspection criteria see ASME B30.9.
- Never apply load except in line with the pivot direction.
- Use only genuine Crosby bolts as replacements.
- Read and understand these warnings and application instructions

**Pivot Hoist Ring Inspection / Maintenance**

- Always inspect pivot hoist ring before use.
- Regularly inspect pivot hoist ring parts (Figure 3).
- Never use pivot hoist ring that shows signs of corrosion, wear or damage.
- Never use pivot hoist ring if bail is bent or elongated.
- Do not use parts showing cracks, nicks or gouges.
- Always be sure threads on bolts and receiving holes are clean, not damaged or worn, and fit properly.
- Always check with torque wrench before using an already installed pivot hoist ring.
- Always make sure there are no spacers (washers) used between pivot hoist ring body and the workpiece surface. Remove any spacers (washers) and retorque before use.
- Always ensure free movement of the bail. The bail should pivot 180 degrees (Figure 4).
- Always be sure total workpiece surface is in contact with the pivot hoist ring body mating surface. Drilled and tapped holes must be 90 degrees to load (workpiece) surface.
- Always make sure that the load is applied in the direction of pivot.

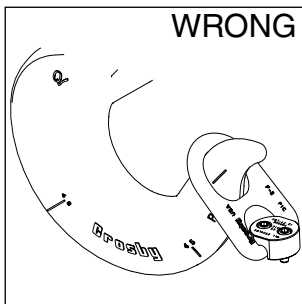

**Figure 1**

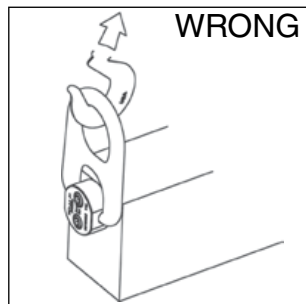

**Figure 2**

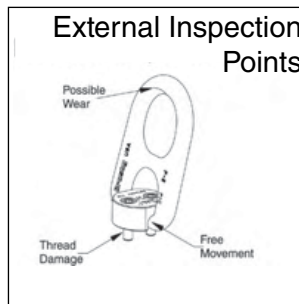

**Figure 3**

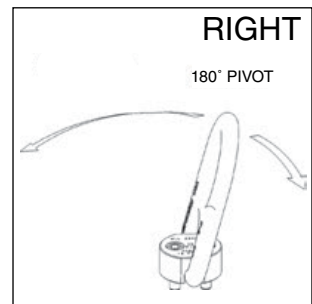

**Figure 4**

## Operating Safety

- Never exceed the capacity (WLL) of the pivot hoist ring, See Table 1 for UNC threads.
- When using lifting slings of two or more legs, make sure the forces in the legs are calculated using the angle from the horizontal sling angle to the leg and select the proper size pivot hoist ring. When using a multi-leg lifting sling, the pivot hoist ring must be mounted so that the pivot direction is inline with the load applied.

Working Load Limit* (lb)	Torque in (ft•lbf) †	No. of Bolts	Dimensions (in)	
			Bolt Size ††	Effective Thread Projection Length
2,000	7	2	5/16 - 18	0.82
2,500	12	2	3/8 - 16	0.65
5,000	28	2	1/2 - 13	1.40
12,000	28	4	1/2 - 13	1.65
20,000	60	4	5/8 - 11	1.65

\* Ultimate load is 5 times the working load limit. Individually proof tested to 2-1/2 times the working load limit.

† Tightening torque values shown are based upon threads being clean, dry and free of lubrication.

\*\* Designed to be used with ferrous workpiece only.

†† Only use Crosby high strength replacement bolts. Do not use any other bolts.

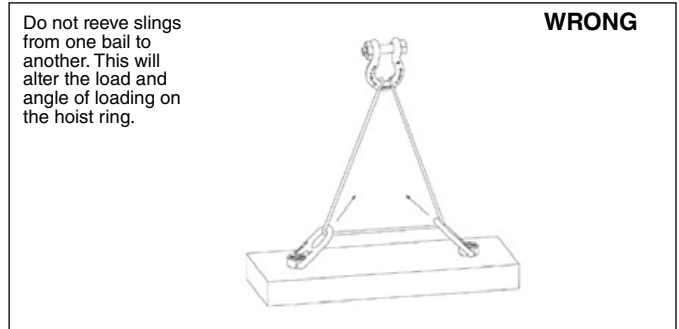
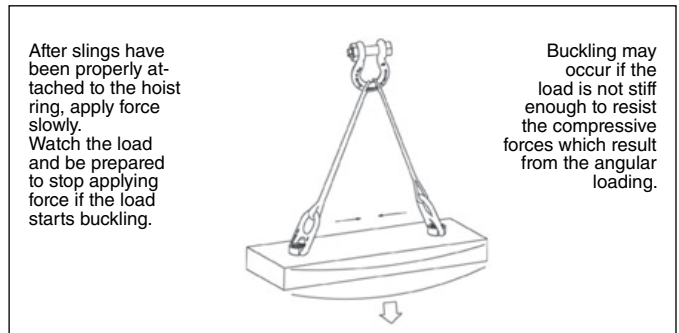



## CROSBY® TRENCH COVER HOIST RING WARNINGS & APPLICATION INSTRUCTIONS



**HR-500**

### Trench Cover Hoist Ring Application / Assembly Instructions

- Use trench cover hoist ring only with ferrous metal (steel, iron) workpiece.
- After determining the loads on each trench cover hoist ring, select the proper size using the Working Load Limit (WLL) ratings in Table 1 (see next page). For proper nut selection, reference trench cover nut welding guidelines (see next page). Nut thickness must equal workpiece thickness.
- For proper welding of nut, reference Nut Welding Guidelines on the following page.
- Always make sure the nut is free of dirt or contaminants before installation of the Trench Cover Hoist Ring. A clean out tool is available from Crosby.
- To install, spin base down flush with workpiece surface and tap one of the lugs on the base with a hammer to tighten; repeat procedure before each use.
- Never use spacers between the trench cover hoist ring base and workpiece surface.
- Always select proper load rated lifting device for use with trench cover hoist ring.
- Attach lifting device ensuring free fit to trench cover hoist ring bail (lifting ring) (Figure 1).
- Apply partial load and check proper rotation and alignment. There should be no interference between load (workpiece) and trench cover hoist ring bail (Figure 2).
- Always ensure free movement of bail. The bail should pivot 180 degrees and swivel 360 degrees (Figure 4).

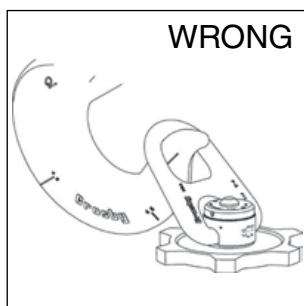

**Figure 1**

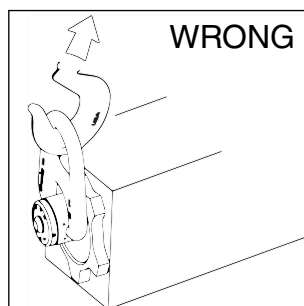

**Figure 2**

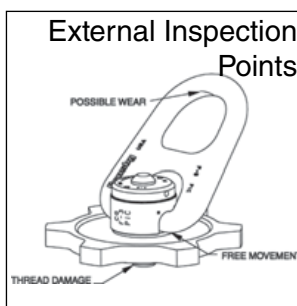

**Figure 3**

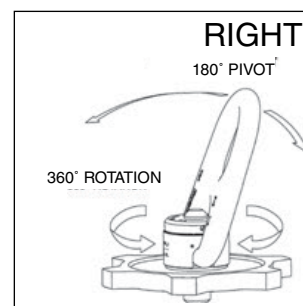

**Figure 4**

### **⚠ WARNING**

- Load may slip or fall if proper Trench Cover Hoist and lifting procedures are not used.
- A falling load can seriously injure or death.
- Do not use with damaged slings or chain. For inspection criteria see ASME B30.9.
- Never apply load except in line with the pivot direction.
- Use only genuine Crosby parts as replacements.
- Read and understand these warnings and application instructions.

### Trench Cover Hoist Ring Inspection / Maintenance

- Always inspect trench cover hoist ring parts before use (Figure 3). Be sure threads on shank and receiving hole are clean, not damaged or worn, and fit properly. A thread gauge is available from Crosby.
- Never use trench cover hoist ring that shows signs of corrosion, wear or damage.
- Never use trench cover hoist ring if bail is bent or elongated.
- Do not use parts showing cracks, nicks or gouges. Always make sure there are no spacers (washers) used between trench cover hoist ring body and the workpiece surface. Remove any spacers (washers) and retighten before use.
- Always be sure total workpiece surface is in contact with the trench cover hoist ring body mating surface.
- Drilled and tapped hole in the weld-in nut must be 90 degrees to load (workpiece) surface. A welding fixture is available from Crosby.
- A visual periodic inspection of the nut to workpiece weld should be performed. Check the weld visually, or use a suitable NDE (Non-Destructive Examination) method if required.

## Operating Safety

- Never exceed the capacity (WLL) of the trench cover hoist ring, see Table 1.
- When using lifting slings of two or more legs, make sure the forces in the legs are calculated using the angle from the horizontal sling angle to the leg and select the proper size trench cover hoist ring.

Working Load Limit (lb)*	Dimensions (in)		Weight Each (lb)
	Coil Thread Size A	Effective Thread Projection Length B	
5,000	1" - 3.5	1.000	8.0
10,000	1-1/4" - 3.5	1.000	16.0
15,000	1-1/2" - 3.5	1.000	28.0

\* Ultimate load is 5 times the working load limit. Individually proof tested to 2-1/2 times the working load limit.

\*\* Designed to be used with ferrous workpiece only.

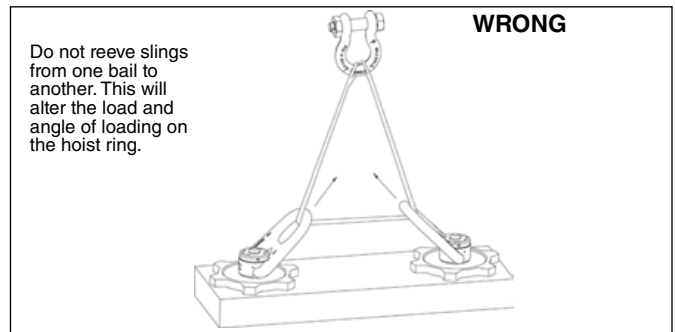
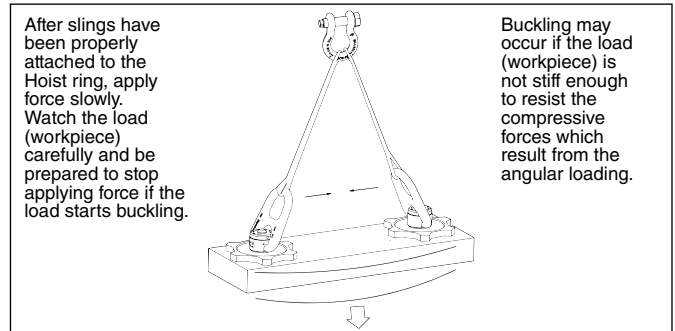

## Trench Cover Nut Welding Guidelines

1. Select the correct size trench cover hoist ring to be used. Be sure to calculate the maximum load that will be applied to the trench cover hoist ring. The nut thickness should be equal to the workpiece thickness.
2. Cut a hole in the workpiece per Table 2 below.
3. Insert the trench cover nut into the hole. The trench cover nut should have 1/16" clearance around its outer edge. The surface of the trench cover nut must be parallel and even with the surface of the workpiece (See Figure 5).
4. A welding fixture is available from Crosby for this.
5. Welding is to be performed by a qualified welder using a qualified procedure in accordance with American Welding Society and/or American Society of Mechanical Engineers requirements.
6. When welding to low or medium carbon cover steel, the following suggestions should be included in the qualified procedure.
  - A. Before welding, all weld surfaces must be clean and free from rust, grease, paint, slag and any other contaminants.
  - B. Weld material is to have a minimum tensile strength of 70,000 PSI (such as AWS A5. 1E-7018). Observe the electrode manufacturer's recommendations.
  - C. Completely fill internal bevel created between trench cover nut and the workpiece.
  - D. Do not rapidly cool the weld.
  - E. The surface of the weld must be ground sufficiently so that the trench cover hoist ring will fit flush against the workpiece.
  - F. Using the same procedure, weld the opposite side.
  - G. A thorough inspection of the weld should be performed. No cracks, pitting, inclusions, notches or undercuts are allowed. If doubt exists, use a suitable NDE method, such as magnetic particle or liquid penetrant to verify.
  - H. If repair is required, grind out the defect and re-weld using the original qualified procedure.

Working Load Limit (lb)	Dimensions (in)			
	Coil Thread Size	Nut Diameter K	Trench Cover Hole Diameter L	Nut Thickness = Workpiece Thickness M
5,000	1" - 3.5	3	3-1/8	3/4
5,000	1" - 3.5	3	3-1/8	7/8
5,000	1" - 3.5	3	3-1/8	1
10,000	1-1/4" - 3.5	3	3-1/8	3/4
10,000	1-1/4" - 3.5	3	3-1/8	7/8
10,000	1-1/4" - 3.5	3	3-1/8	1
10,000	1-1/4" - 3.5	3	3-1/8	1-1/4
10,000	1-1/4" - 3.5	3	3-1/8	1-1/2
15,000	1-1/2" - 3.5	3-1/2	3-5/8	1
15,000	1-1/2" - 3.5	3-1/2	3-5/8	1-1/4
15,000	1-1/2" - 3.5	3-1/2	3-5/8	1-1/2

**NOTE: For welding to other grades of steel, a qualified weld procedure must be developed.**

Figure 5

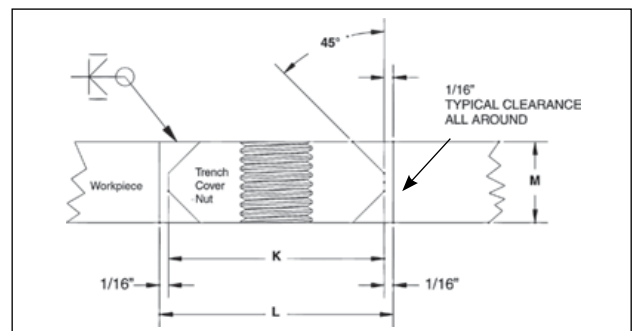

## SIDE PULL HR-1200

### WARNINGS & APPLICATION INSTRUCTIONS



HR-1200

### Hoist Ring Application / Assembly Instruction

- The Crosby side pull swivel hoist ring is designed to accept standard Crosby fittings to facilitate wider slings and quick attachment. In order to use the larger fittings, the load rating on the (shackle) fitting may be greater than the hoist ring frame. **Never exceed the Working Load Limit of the hoist ring frame.**
- Use swivel hoist ring only with a ferrous metal (steel, iron) or non-ferrous (i.e., aluminum) loads (workpiece). Do not leave threaded end of hoist ring in aluminum loads for long time periods due to corrosion.
- After determining the loads on each hoist ring, select the proper size hoist ring using the Working Load Limit ratings in Table 1 for UNC threads and Table 2 for Metric threads (on next page.)
- For Subsea or Metric environment application, use the HR-1200 CT Series hoist ring only.
- Drill and tap the workpiece to the correct size to a minimum depth of one-half the threaded shank diameter plus the threaded shank length.
- Install hoist ring to recommended torque with a torque wrench making sure the bushing flange is fully supported by the load (workpiece) surface. See rated load limit and bolt torque requirements imprinted on hoist ring body (See Table 1 or Table 2).
- Never use spacers between bushing flange and mounting surface.
- Always select proper lifting device for use with Swivel Hoist Ring (See Tables 1 & 2 on next page).
- Attach lifting device ensuring free fit to hoist shackle (See Figure 3).
- Apply partial load and check proper rotation and alignment of shackle. There should be no interference between load (workpiece) and hoist shackle (See Figure 1 and Figure 3).
- The Hoist ring should rotate into normal operating position, with shackle aligned with load as shown in Figure 3. If shackle is oriented as shown in Figure 4, **DO NOT LIFT.**
- Special Note:** when a Hoist Ring is installed with a retention nut, the nut must have full thread engagement and must meet one of the following standards to develop the Working Load Limit (WLL).
  - ASTM A-563 (A) Grade D Hex Thick
  - (B) Grade DH Standard Hex
  - SAE Grade 8 - Standard Hex

### Hoist Ring Inspection / Maintenance

- Always inspect hoist ring before use.
- Regularly inspect hoist ring parts (Figure 2).
- For hoist rings used in frequent load cycles or on pulsating loads, the bolt threads should be periodically inspected by magnetic particle or dye penetrant.
- Do not use part showing cracks, nicks or gouges.
- Repair minor nicks or gouges to hoist frame by lightly grinding until surfaces are smooth. Do not reduce original dimension more than 10%. Do not repair by welding.

**⚠ WARNING**

- Loads may slip or fall if proper Hoist Ring assembly and lifting procedures are not followed.
- A falling load may cause serious injury or death.
- Install hoist ring bolt to torque requirements listed in tables.
- The side pull hoist ring frame will be only one part of a lifting system with several components (i.e., shackles and slings). Never exceed the Working Load Limit of the hoist ring frame.
- Do not use damaged slings or chain. For inspection criteria, see ASME B30.9.
- Read and understand these instructions before using hoist ring.
- Use only genuine Crosby parts as replacements.

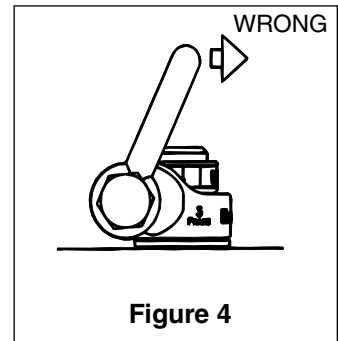
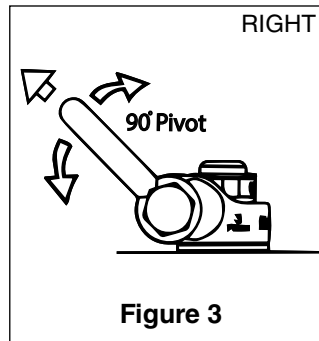
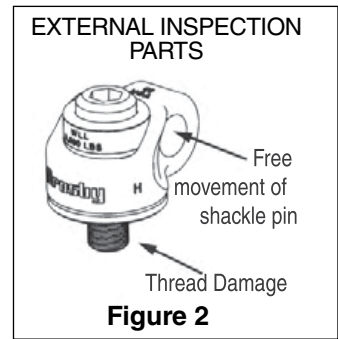
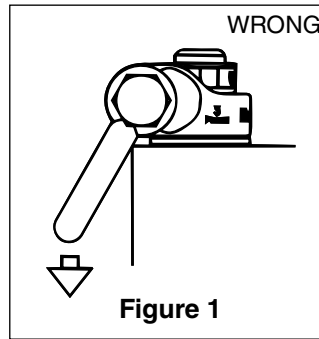

- Never use hoist ring that shows signs of corrosion, wear or damage.
- Never use hoist ring if components are bent or elongated.
- Always be sure threads on bolt and receiving tapped holes are clean, undamaged, and fit properly.
- Always check with torque wrench before using an already installed hoist ring.
- Always make sure there are no spacers (washers) used between bushing flange and the mounting surface. Remove any spacers (washers) and retorquer before use.
- Always ensure free movement of shackle. The shackle should pivot 90° and the hoist ring should swivel 360° (See Figure 3).
- Always be sure total workpiece surface is in contact with hoist ring bushing mating surface. Drilled and tapped hole must be 90° to load (workpiece) surface.

# OPERATING SAFETY

- Never exceed the capacity of the hoist ring, see Table 1 for UNC threads and Table 2 for Metric threads.
- When using lifting slings of two or more legs, make sure the forces in the legs are calculated using the angle from the horizontal sling angle to the leg and select the proper size swivel hoist ring to allow for the angular forces.

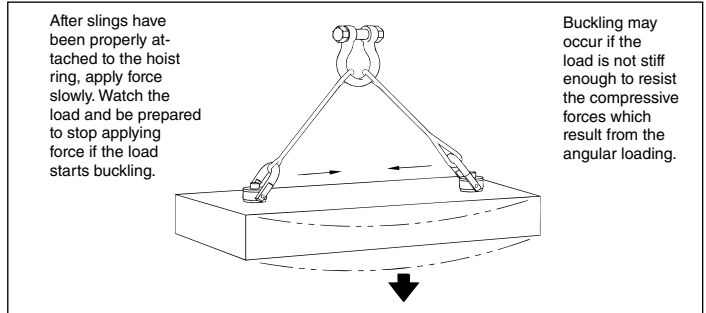
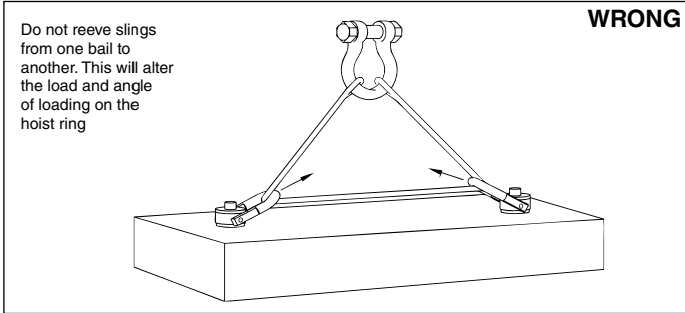

**HR1200 Threads**

**TABLE 1**

Frame Size	Working Load Limit * (lb)	Hoist Ring Bolt Torque in (ft•lbf) †	Bolt Size ‡ (in)	Effective Thread Projection Length (in)	Recommended Shackles	
					Red Pin® Shackles 209, 210, 213 215, 2130, 2150	Red Pin® Web Shackles S-281
1	650††	7	5/16 - 18 x 1.5	.59	1/2" - (2) 5/8" - (3-1/4)	2" - (3-1/4)
	800††	12	3/8 - 18 x 1.5	.59		
2	2000	28	1/2 - 13 x 2.0	.71	5/8" - (3-1/4) 3/4" - (4-3/4)	2" - (3-1/4) 1-1/2" - (4-1/2)
	2000††	28	1/2 - 13 x 2.5	1.21		
	3000	60	5/8 - 11 x 2.0	.71		
	3000††	60	5/8 - 11 x 2.75	1.46		
3	5000	100	3/4 - 10 x 2.75	1.46	7/8" - (6-1/2)	2" - (6-1/4)
	5000††	100	3/4 - 10 x 3.5	1.63		
	6500	160	7/8 - 9 x 2.5	.90		
	6500††	160	7/8 - 9 x 3.5	1.68		
	8000	230	1 - 8 x 3.0	1.15		
	8000††	230	1 - 8 x 4.0	2.15		
4	14000	470	1-1/4 - 7 x 4.5	2.22	1" - (8-1/2) 1-1/8" - (9-1/2) 1-1/4" - (12)	3" - (8-1/2)
5	17200 29000	800 1100	1-1/2 - 6 x 6.5 2 - 4-1/2 x 6.5	2.88 2.98	1-3/8" - (13-1/2) 1-1/2" - (17) 1-3/4" - (25)	—

**HR1200M UNC Metric Threads**

**TABLE 2**

Frame Size	Working Load Limit * (kg)	Hoist Ring Bolt Torque in Nm †	Bolt Size ‡ (mm)	Effective Thread Projection Length (mm)	Recommended Shackles	
					Red Pin® Shackles 209, 210, 213 215, 2130, 2150	Red Pin® Web Shackles S-281
1	300	10	M8 x 1.25 x 40	16.9	1/2" - (2) 5/8" - (3-1/4)	2" - (3-1/4)
	400	16	M10 x 1.5 x 40	16.9		
2	1000	38	M12 x 1.75 x 50	17.2	5/8" - (3-1/4) 3/4" - (4-3/4)	2" - (3-1/4) 1-1/2" - (4-1/2)
	1400	81	M16 x 2.00 x 60	27.2		
3	2250	136	M20 x 2.50 x 75	28.1	7/8" - (6-1/2)	2" - (6-1/4)
	3500	312	M24 x 3.00 x 80	33.1		
4	6250	637	M30 x 3.5 x 120	65.1	1" - (8-1/2) 1-1/8" - (9-1/2) 1-1/4" - (12)	3" - (8-1/2)
5	7750	1005	M36 x 4.0 x 150	60.6	1-3/8" - (13-1/2) 1-1/2" - (17) 1-3/4" - (25)	—
	10000	1005	M42 x 4.5 x 160	70.6		
	13000	1350	M48 x 5.0 x 160	70.6		

Designed to be used with Ferrous workpiece only.

\* Ultimate load is 5 times the Working Load Limit. Individually proof tested to 2-1/2 times the Working Load Limit.

† Tightening torque values shown are based upon threads being clean, dry and free of lubrication.

†† Long bolts are designed to be used with soft metal (i.e., aluminum) workpiece. While the long bolts may also be used with ferrous metal (i.e., steel & iron) workpieces, short bolts are designed for ferrous workpieces only.

‡ Bolt specification is a Grade 8 Alloy socket head cap screw to ASTM A574. All threads are UNC - 3A.

‡‡ Bolt specification is a Grade 12.9 Alloy socket head cap to DIN 912. All threads are metric (ASME/ANSI B18.3.1m).

Rigging Accessories



# CROSBY® WELD-ON PIVOTING LINK

## WARNING & APPLICATION INSTRUCTIONS



S-265

### ⚠ WARNING

- Loads may disengage from link if proper welding, assembly, and lifting procedures are not used.
- A falling load may cause serious injury or death.
- Do not use with damaged slings or chain. For sling inspection criteria see ASME B30.9.
- Read and understand these instructions before welding on, or using the pivoting link.

### Important Safety Information - Read and Follow

- Use weld-on pivoting link only with ferrous metal (steel) workpiece.
- After determining the loads on each weld-on pivoting link, select the proper size using the Working Load Limit (WLL) ratings in Table 1 on next page.
- Always make sure the weld-on pivoting link and mounting surface is free of dirt or contaminants before installation.
- Never use spacers between the weld-on pivot link and mounting surface.
- Always select proper load rated lifting device for use with weld-on pivoting link.
- Attach lifting device ensuring free movement of weld-on pivoting link bail (Figure 1).
- Apply partial load and check proper alignment. There should be no interference between load (workpiece) and weld-on pivoting link (Figure 2).
- Always ensure free movement of bail. The bail should pivot 180 degrees (Figure 4).
- The support structure that the pivot link is attached to must be of suitable size, composition and quality to support the anticipated loads of all operating positions. The required support structure thickness for a given application is dependent on variables such as unsupported length and material strength, and should be determined by a qualified individual.
- Never repair, alter, rework or reshape the pivoting link bail by welding, heating, burning or bending.

### Weld-on Pivoting Link Inspection / Maintenance

- Always inspect weld-on pivoting link before use.
- Regularly inspect weld-on pivoting link parts (Figure 3).
- Never use weld-on pivoting link that shows signs of corrosion, wear or damage.
- Never use weld-on pivoting link if bail is bent or elongated.
- Do not use part showing cracks, nicks or gouges.
- Always make sure there are no spacers used between weld-on pivoting link and the mounting surface.
- Always be sure workpiece surface is in total contact with the weld-on pivoting link base mating surface.
- Always inspect the weld-on pivoting link bail and base for wear.
- A visual periodic inspection of the weld should be performed. Check the weld visually, or use a suitable NDE method if required.

### Operating Safety

- Never exceed the capacity (WLL) of the weld-on pivoting link (Table 1, next page).
- Always apply load within 90° of inline, at any pivot angle (Figure 4 & 5).
- When using lifting slings of two or more legs, make sure the forces in the legs are calculated using the angle from the horizontal sling angle to the leg and select the proper size link.

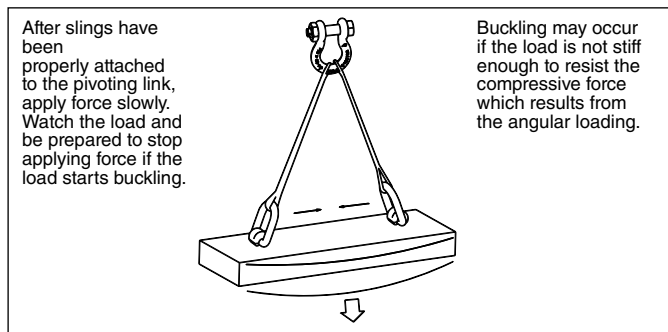
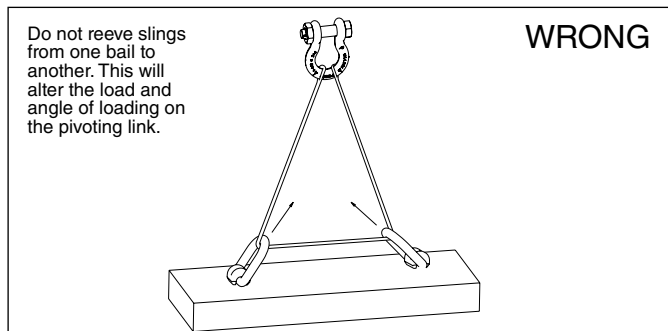

Figure 1

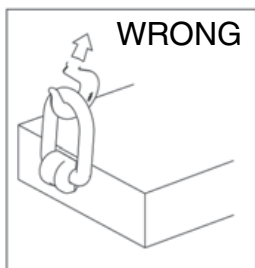

Figure 2

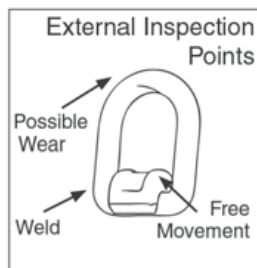

Figure 3

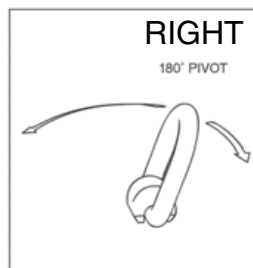

Figure 4

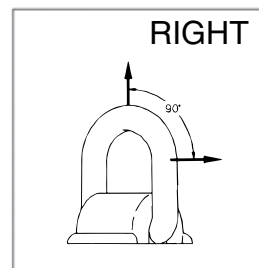
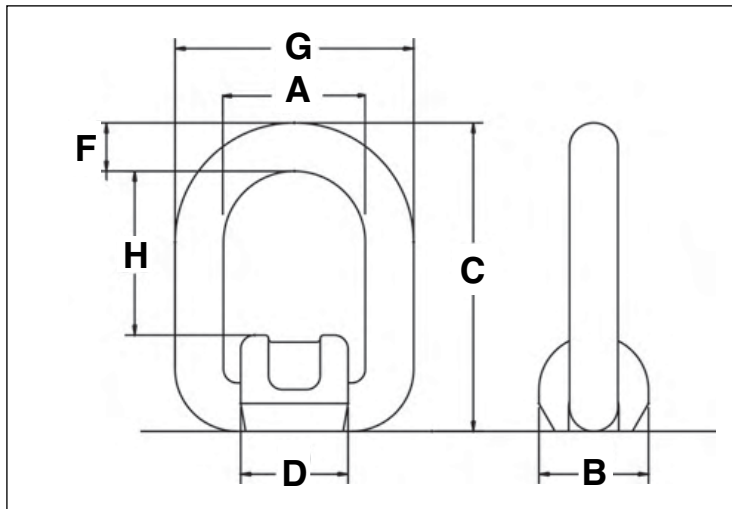

Figure 5

## Weld-on Pivoting Link Welding Guidelines

1. Select the correct size weld-on pivoting link to be used. Be sure to calculate the maximum load that will be applied to the weld-on pivoting link.
2. Place the weld-on pivoting link onto the mounting surface. The bottom of the link base must be parallel and even with the mounting surface.
3. Welding is to be performed by a qualified welder using a qualified procedure in accordance with American Welding Society and/or American Society of Mechanical Engineers requirements. Always follow your country or local mandatory regulations or codes.
4. The following welding recommendations should be included in the qualified procedure for welding to low or medium carbon plate steel. For welding to other grades of steel, a qualified weld procedure must be developed.
  - A. Saddle material is equivalent to SAE/AISI 1024, EN S355J2, or DIN 1.0570.
  - B. Weld material is to have a minimum tensile strength of 70,000 PSI (such as AWS A5.1 E-7018). Observe the electrode manufacturer's recommendations. Completely fill internal fillet created between weld-on pivoting link base and mounting surface.
  - C. Before welding, all weld surfaces must be clean and free from rust, grease, paint, slag and any other contaminants.
  - D. Fillet weld leg size should be minimum shown in Table 1. Weld profiles to be in accordance with AWS. Weld size is measured by length of leg.
  - E. Welding should be carried out in a minimum of two passes to ensure adequate root penetration at the base of the pivoting link.
  - F. Weld full length of "D" dimension on both sides of link base (Figure 5).
  - G. Do not weld close to the bail. After welding, ensure bail pivots full 180° without interfering with the weld.
  - H. Do not rapidly cool the weld.
    - I. The ends of the weld must be ground sufficiently so that the weld-on pivoting link will fit flush against the mounting surface.
    - J. A thorough inspection of the weld should be performed. No cracks, pitting, inclusions, notches or undercuts are allowed. If doubt exists, use a suitable NDE method, such as magnetic particle or liquid penetrant to verify.
    - K. If repair is required, grind out the defect and re-weld using the original qualified procedure.



**Figure 5**

Table 1 S-265 Weld-on Pivoting Links*											
Stock Number	Working Load Limit (t)		Dimensions (in)								Weight Each (lb)
	Design Factor 5:1	Design Factor 4:1	A	B	C	D	F	G	H	Minimum Fillet Weld Size	
1290740	1	1.2	1.57	1.42	3.27	1.38	0.51	2.60	1.65	3/32	.88
1290768	2.5	3.2	1.77	1.73	3.90	1.65	0.71	3.19	1.89	3/32	1.32
1290786	4	5	2.17	1.97	4.84	1.93	0.87	3.90	2.24	1/4	2.65
1290802	6.4	8	2.76	2.52	5.67	2.52	1.02	4.80	2.64	1/4	5.29
1290820	12	15	3.82	3.54	7.60	3.39	1.34	6.50	3.70	5/16	13.01

\*Designed to be used with ferrous workpiece only.

# CROSBY SWIVEL HOIST RING

## WARNING & APPLICATION INSTRUCTIONS



**HR-125/SS-125**  
(Red Washer)  
**HR-125M**  
**SS-125M**  
(Silver Washer)



**HR-1000**  
(Red Washer)  
**HR-1000M**  
(Silver Washer)  
**HR-1000CT**  
(Blue Washer)

### Hoist Ring Application Assembly Safety

Use swivel hoist ring only with a ferrous metal (steel, iron) or soft metal (i.e., aluminum) load (workpiece). Do not leave threaded end of hoist ring in aluminum loads for long time periods due to corrosion.

For subsea or marine environment applications, use the HR-1000CT series Hoist Ring only.

- After determining the loads on each hoist ring, select the proper size hoist ring using the Working Load Limit ratings in Tables 1, 2, and 5 for UNC threads and Tables 3, 4 and 6 for Metric threads (on next page).
- Drill and tap the workpiece to the correct size to a minimum depth of one-half the threaded shank diameter plus the threaded shank length. See rated load limit and bolt torque requirements imprinted on top of the swivel trunnion (See Table 1 through Table 6 on next page).
- When a hoist ring is used in a side load application, ensure equal loading on the pins by aligning the bail as shown in (Fig. 3).
- Always be sure total hoist ring bushing mating surface is in contact with the (workpiece) surface. Drilled and tapped hole must be 90 degrees to load (workpiece) surface.
- Install hoist ring to recommended torque with a torque wrench making sure the bushing flange meets the load (workpiece) surface.
- Never use spacers between bushing flange and mounting surface.
- Always select proper load rated lifting device for use with Swivel Hoist Ring.
- Attach lifting device ensuring free fit to hoist ring bail (lifting ring) (Fig. 1).
- Apply partial load and check proper rotation and alignment. There should be no interference between load (workpiece) and hoist ring bail (Fig. 2).
- Special Note: When a Hoist Ring is installed with a retention nut, the nut must have a full thread engagement and must meet one of the following standards to develop the Working Load Limit (WLL).

#### UNC NUTS

- 1. ASTM A-563**  
Grade D  
(Heavy Hex or Hex Thick)  
Grade DH  
Grade DH3
- 2. ASTM A-194**  
Grade 2H  
Grade 4  
Grade 7
- 3. FNL**  
Grade 9
- 4. SAE J995**  
Grade 8

#### METRIC NUTS

- 1. ASTM A-563M**  
Class 10S
- 2. ISO 898-2**  
(EN 20898-2/DIN 267-4)  
Class 10  
Class 12

### Hoist Ring Inspection / Maintenance

- Always inspect hoist ring before use.
- Regularly inspect hoist ring parts.
- Never use hoist ring that shows signs of corrosion, wear or damage.
- Never use hoist ring if bail is bent or elongated.
- Always be sure threads on shank and receiving hole are clean, not damaged, and fit properly.

- Always check with torque wrench before using an already installed hoist ring.
- Always make sure there are no spacers (washers) used between bushing flange and the mounting surface. Remove any spacers (washers) and retorque before use.
- Prior to loading always ensure free movement of bail. The bail should pivot 180 degrees and swivel 360 degrees.

**⚠ WARNING**

- **Loads may slip or fall if proper Hoist Ring assembly and lifting procedures are not used.**
- **A falling load may cause serious injury or death.**
- **Install hoist ring bolt to torque requirements listed in tables 1, 2, 3, 4, 5, & 6 for the HR-125, HR-1000, HR-1000CT, HR-125M, HR-1000M and SS-125.**
- **Read, understand and follow all instructions and chart information.**
- **Do not use with damaged slings, chain, or webbing. For inspection criteria see ASME B30.9.**
- **Use only genuine Crosby parts as replacements.**

### Operating Safety

- Never exceed the capacity of the swivel hoist ring, see Tables 1, 2 and 5 for UNC threads and Tables 3, 4 and 6 for Metric threads. (See next page for tables.)
- When using lifting slings of two or more legs, make sure the forces in the legs are calculated using the angle from the horizontal sling angle to the leg and select the proper size swivel hoist ring to allow for the angular forces.

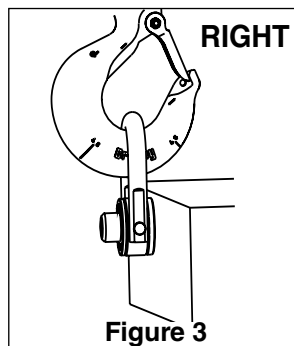
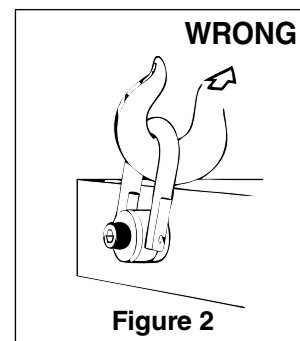
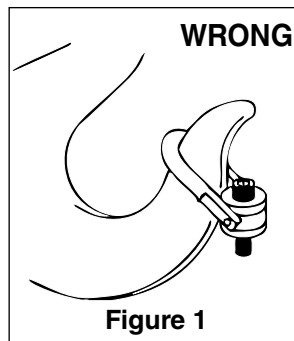
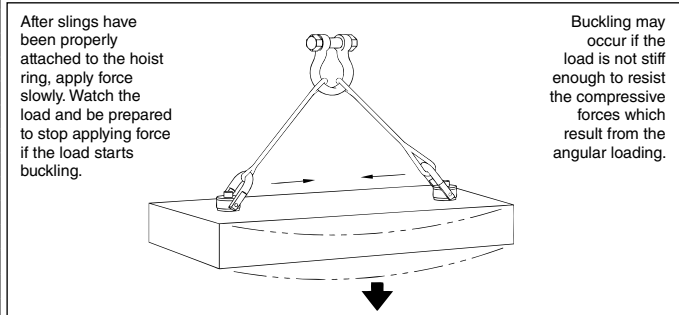
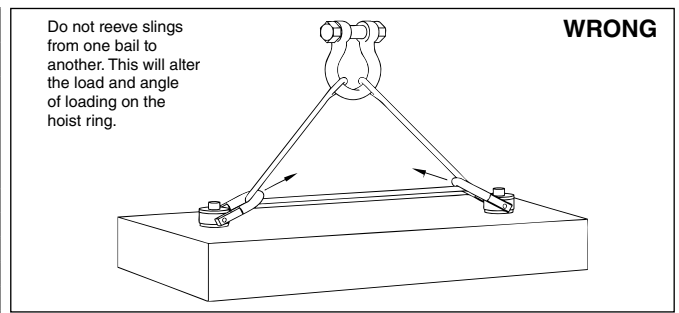

Table 1					
Working Load Limit* 5:1 (lb)	Hoist Ring Bolt Torque (ft•lbf) †	HR-125		HR-1000	
		Bolt Size ‡ (in)	Effective Thread Projection Length (in)	Bolt Size ‡ (in)	Effective Thread Projection Length (in)
800 ††	7	5/16 - 18 x 1.50	.58	5/16 - 18 x 1.50	.52
1000 ††	12	3/8 - 16 x 1.50	.58	3/8 - 16 x 1.50	.52
2500	28	1/2 - 13 x 2.00	.70	1/2 - 13 x 2.25	.69
2500 ††	28	1/2 - 13 x 2.50	1.20	1/2 - 13 x 2.75	1.19
4000	60	5/8 - 11 x 2.00	.70	5/8 - 11 x 2.25	.69
4000 ††	60	5/8 - 11 x 2.75	1.45	5/8 - 11 x 3.00	1.44
5000	100	3/4 - 10 x 2.25	.95	3/4 - 10 x 2.50	.94
5000 ††	100	3/4 - 10 x 2.75	1.45	3/4 - 10 x 3.00	1.44
7000 Ω	100	3/4 - 10 x 2.75	.89	3/4 - 10 x 3.00	.85
7000 ††Ω	100	3/4 - 10 x 3.50	1.64	3/4 - 10 x 3.50	1.35
8000	160	7/8 - 9 x 2.75	.89	7/8 - 9 x 3.00	.85
8000 ††	160	7/8 - 9 x 3.50	1.64	7/8 - 9 x 3.50	1.35
10000	230	1 - 8 x 3.00	1.14	1 - 8 x 3.50	1.35
10000 ††	230	1 - 8 x 4.00	2.14	1 - 8 x 4.50	2.35
15000	470	1-1/4 - 7 x 4.50	2.21	1-1/4 - 7 x 5.00	2.09
24000	800	1-1/2 - 6 x 6.75	2.97	1-1/2 - 6 x 5.50	2.59
30000	1100	2 - 4-1/2 x 6.75	2.97	—	—
50000	2100	2-1/2 - 4 x 8.00	4.00	—	—
75000	4300	3 - 4 x 10.50	5.00	—	—
100000	5100	3-1/2 - 4 x 13.00	7.00	—	—



Ω Ultimate Load is 4.5 times Working Load Limit for 7000# Hoist Ring when tested in 90° orientation. All sizes are individually proof tested to 2-1/2 times the Working Load Limit. \*, †, ††, ‡ (See footnotes at bottom of Table 5).

Table 2				
Working Load Limit (kg) ****		HR-1000MCT		
Design Factor 5:1	Design Factor 4:1	Hoist Ring Bolt Torque in (Nm) †	Bolt Size (mm) ‡	Effective Thread Projection Length (mm)
825	1030	38	M12 x 1.75 x 55	15.6
1350	1690	81	M16 x 2.00 x 65	25.5
2250	2810	136	M20 x 2.50 x 80	25.3
3175	3970	312	M24 x 3.00 x 90	35.4
5450	6810	637	M30 x 3.50 x 140	65.9
7450	9310	1005	M36 x 4.00 x 130	56.3
13250	16560	1350	M48 x 5.00 x 180	50.7

Table 3			
HR-1000CT			
Working Load Limit 5:1 (lb) ****	Hoist Ring Bolt Torque in (ft•lbf) †	Bolt Size (in) Δ	Effective Thread Projection Length (in)
1900	28	1/2 - 13 x 2.25	.70
1900	28	1/2 - 13 x 2.75	1.20
3000	60	5/8 - 11 x 2.25	.70
4800	100	3/4 - 10 x 3.00	.85
6200	160	7/8 - 9 x 3.00	.85
8300	230	1 - 8 x 3.50	1.35
12500	470	1 1/4 - 7 x 5.00	2.10
20000	800	1 1/2 - 6 x 5.50	2.60
20000	800	1 1/2 - 8 x 5.50	2.60
28000	1100	2 - 4.5 x 7.50	3.20
45000	2100	2 1/2 - 4 x 9.50	3.73

Table 4						
Working Load Limit (kg)***		Hoist Ring Bolt Torque in (Nm) †	HR-125M		HR-1000M	
Design Factor 5:1	HR-125M Design 4:1		Bolt Size ‡ (mm)	HR-125M Effective Thread Projection Length (mm)	Bolt Size ‡ (mm)	HR-1000M Effective Thread Projection Length (mm)
400	500	10	M 8 X 1.25 X 40	16.9	M 8 X 1.25 X 40	15.2
450	550	16	M 10 X 1.50 X 40	16.9	M 10 X 1.50 X 40	15.2
1050	1300	38	M 12 X 1.75 X 50	17.2	M 12 X 1.75 X 55	15.5
1900	2400	81	M 16 X 2.00 X 60	27.2	M 16 X 2.00 X 65	25.5
2150	2700	136	M 20 X 2.50 X 65	31.2	M 20 X 2.50 X 70	30.5
3000	3750	312	M 20 X 2.50 X 75	28.1	M 20 X 2.50 X 80	25.4
4200	5250	637	M 24 X 3.00 X 80	33.1	M 24 X 3.00 X 90	35.4
7000	8750	1005	M 30 X 3.50 X 120	65.1	M 30 X 3.50 X 140	66.2
11000	13750	1350	M 36 X 4.00 X 150	60.6	M 36 X 4.00 X 150	56.2
12500	15600	1005	M 42 x 4.50 x 160	70.6	—	—
13500	16900	1350	M 48 x 5.00 x 160	101	—	—
22300	27900	2847	M 64 x 6.00 x 204	101	—	—
31500	39400	5830	M 72 x 6.00 x 265	132	—	—
44600	55800	6914	M 90 x 6.00 x 330	177	—	—

See Footnotes on next page.



† Tightening torque values shown are based upon threads being clean, dry and free of lubrication.

**Footnotes below relate to tables 1-4**

\* Ultimate load is 5 times the Working Load Limit. Individually proof tested to 2-1/2 times the Working Load Limit.

\*\* Ultimate load is 4 times the Working Load Limit. Individually proof tested to 2-1/2 times the Working Load Limit.

\*\*\* Individually proof tested to 2-1/2 times the Working Load Limit based on 4:1 design factor

\*\*\*\* Ultimate load is 5 times the Working Load Limit. Individually proof tested to 2 times the Working Load Limit.

†† Long bolts are designed to be used with soft metal (i.e., aluminum) workpiece. While the long bolts may also be used with ferrous metal (i.e., steel & iron) workpieces, short bolts are designed for ferrous workpieces only.

‡ Bolt specification is a Alloy socket head cap screw to ASTM A574. All threads are UNC .

‡‡ Bolt specification is a Grade 12.9 Alloy socket head cap screw to DIN 912. All threads are metric (ASME/ANSI B18.3.1m)

Δ Bolt specification is a Grade L7 or L43 Alloy socket head cap screw to ASTM A320. All threads are UNC.

‡‡‡ Tighten bolt to specified torque, then tighten nut to specified torque.

**All Swivel Hoist Rings are individually proof tested.**

Table 5			
SS-125 ¥¥			
Working Load Limit (lb) ¥	Torque in (ft•lbf) †	Bolt Size (in) §	Effective Thread Projection (in)
400	3.5	5/16 - 18 x 1	.29
400	3.5	5/16 - 18 x 1.25	.54
500	6	3/8 - 16 x 1.25	.54
1250	14	1/2 - 13 x 2	.78
1250	14	1/2 - 13 x 2.25	1.03
1250	14	1/2 - 13 x 2.5	1.28
2000	30	5/8 - 11 x 2	.78
2000	30	5/8 - 11 x 2.25	1.03
2000	30	5/8 - 11 x 2.5	1.28
2500	50	3/4 - 10 x 2.25	1.03
2500	50	3/4 - 10 x 2.75	1.53
3500	50	3/4 - 10 x 2.75	1.04
3500	50	3/4 - 10 x 3.25	1.54
4000	80	7/8 - 9 x 2.75	1.04
4000	80	7/8 - 9 x 3	1.29
5000	115	1 - 8 x 3	1.29
5000	115	1 - 8 x 3.25	1.54
5000	115	1 - 8 x 4	2.29
7500	235	1-1/4 - 7 x 4	1.89
12000	400	1-1/2 - 6 x 5.5	2.70
15000	550	2 - 4-1/2 x 5.75	2.96
25000	1050	2-1/2 - 4 x 8	4.00
25000	1050	2-1/2 - 8 x 8	4.00
37500	2150	3 - 4 x 10.25	5.00
50000	2550	3-1/2 - 4 x 13	7.00

Table 6			
SS-125M ¥¥			
SS-125M ¥¥ Working Load Limit (kg) ¥	Torque in Lbs. †	Bolt Size (mm) §§	Effective Thread Projection (mm)
200	4	M 8 x 1.25x30	13
250	8	M 10 x 1.50x35	18
525	18	M 12 x 1.75x50	19
950	40	M 16 x 2.00x60	29
1075	68	M 20 x 2.50x65	34
1500	68	M 20 x 2.50x75	32
2100	108	M 24 x 3.00x80	37
2100	108	M 30 x 3.50x110	58
3500	318	M 30 x 3.50x95	42
3500	318	M 30 x 3.50x115	62
5500	542	M 36 x 4.00x135	64
6250	542	M 42 x 4.50x155	82
6750	746	M 48 x 5.00x155	82
11150	1423	M 64 x 6.00x205	101
15750	2915	M 72 x 6.00x265	132
22300	3459	M 90 x 6.00x330	177

**Footnotes below relate to Tables 5 and 6**

¥ Ultimate load is 5 times the Working Load Limit. Individually proof tested to 2 times the Working Load Limit.

¥¥ All components are 316 Stainless Steel, except Bolt Retainers, which are made from 15-7 PH (UNS 15700) magnetic stainless steel.

§ Bolt specification is 316 Stainless Steel socket head cap screw to ASTM F837 Group 1 (316).

§§ Bolt specification is 316 Stainless Steel socket head cap screw to ASTM F837M (316). All threads are Metric (ASME/ANSI B18.3.1M).

# CROSBY® THIMBLE EYE BUNDLE CLIPS

## WARNING & APPLICATION INSTRUCTIONS

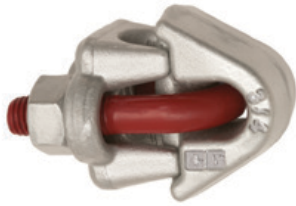

G-461

The Bundle Clip is utilized in a choker hitch application to maintain the shape of bundled packages after a load is placed. The Bundle Clip is attached to live line of choker hitch, but it is never to be used as a button or ferrule to carry a load in the primary load path.

Certain conditions (such as extreme variation of the choke size) or improper installation may cause the eye of the choke hitch to disengage from the Bundle Clip and allow the eye to seat away from or below the Bundle Clip (see Figure 3). If this occurs, the Bundle Clip must be removed and installed in the proper position.

The Bundle Clip is sized to provide a grip to the live rope without reducing the efficiency of a choker hitch. This grip is adequate to keep the bundle clip in position.

These instructions are for use with thimble eyes formed with RRL or RLL wire rope, 6 x 19 or 6 x 36 Class, FC or IWRC; IPS or XIP, XXIP, and a Crosby Thimble. For other classes of wire rope not mentioned above, we recommend contacting Crosby Engineering.

**For Soft Eye applications see the Crosby G-460 Soft Eye Bundle Clip.**

**For OSHA (Construction) applications, see OSHA 1926.251.**

1. The eye of the sling must be in the choked position (around live line). Choker hitch applications should comply with the requirements of ASME B30.9 Slings. Install the choker hitch to provide a minimum choke angle of 120 degrees (See Figure 1). Refer to ASME B30.9 for required de-rating of the sling if choke angle is less than 120 degrees.

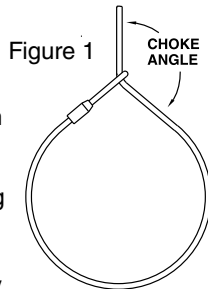

2. Before installing Bundle Clip, apply initial load by lifting the bundle and clearing the support, producing a tight choke. Repeat as necessary until the bundle package is in the most compact position (See figure 2, Loaded).

**Keep hands and feet from under load.**

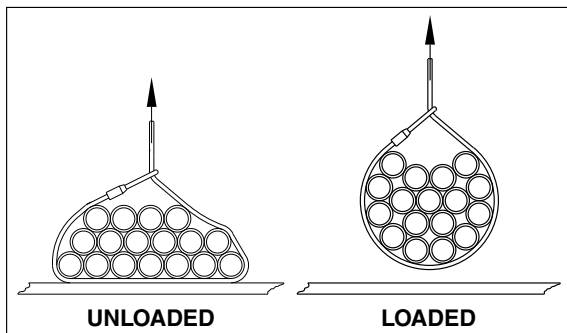

Figure 2

## WARNING

- Failure to read, understand, and follow these instructions may cause death or serious injury.
- A falling load may seriously injure or kill.
- Read and understand these instructions before using clips.
- Failure to properly position the Bundle Clip may allow the load to slip and fall.
- Match the same size clip to the same size wire rope.
- Install Bundle Clip only as instructed.
- Do not use with plastic coated wire rope.
- Do not use for lifting personnel.

3. After initial loading, install the Bundle Clip. The orientation of the Bundle Clip on the live line is not an important consideration, as the assembly is of adequate size to prevent passage through proper size Crosby Thimble and next larger size Thimble. Insert U-bolt through the Bundle Clip. Properly position the clip base over the U-bolt and install nuts (See Figure 3). Use torque wrench to tighten evenly, alternating from one nut to the other until the bundle stop bottoms out on the clip base, and the recommended torque is reached (See Table 1).

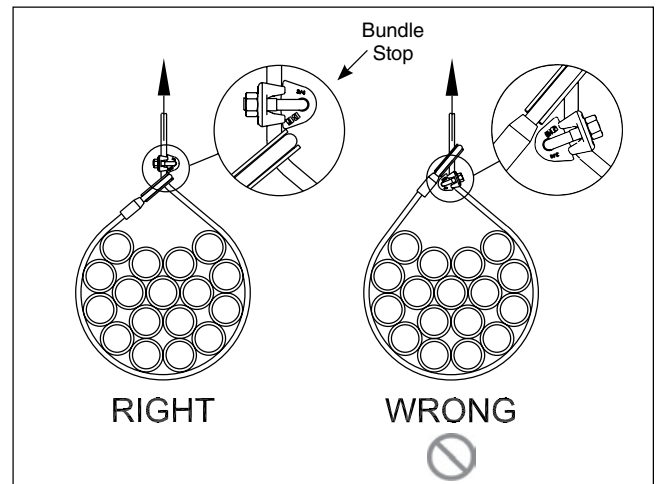

Figure 3

Table 1 – Recommended Torque

Clip Size	Rope Size (in)	Torque (Ft.-Lb.)
5/8	5/8	95
3/4	3/4	130
7/8	7/8	225

4. Before each lift, check to ensure that the choke eye has not slipped from the Bundle Clip. Repeat Step 3 if necessary.
5. When disconnecting, the load should be clear of the stable support (See figure 2, Loaded). Remove Bundle Clip. Stay clear of the load as the bundle is lowered and the load is removed from the sling.

In accordance with good rigging and maintenance, the wire rope sling should be inspected periodically for wear, abuse, and general adequacy.

# CROSBY® SOFT EYE BUNDLE CLIPS

## WARNING & APPLICATION INSTRUCTIONS

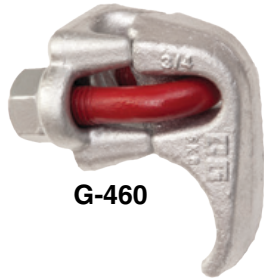

G-460

The Bundle Clip is utilized in a choker hitch application to maintain the shape of bundled packages after a load is placed. The Bundle Clip is attached to live line of choker hitch, but it is never to be used as a button or ferrule to carry a load in the primary load path.

Certain conditions (such as extreme variation of the choke size) or improper installation may cause the eye of the choke hitch to disengage from the Bundle Clip and allow the eye to seat away from or below the Bundle Clip (see Figure 3). If this occurs, the Bundle Clip must be removed and installed in the proper position.

The Bundle Clip is sized to provide a grip to the live rope without reducing the efficiency of a choker hitch. This grip is adequate to keep the bundle clip in position. The eye may pull free of the Bundle Clip if not positioned properly.

These instructions are for use with soft eyes (no thimble) formed with RRL or RLL wire rope, 6 x 19 or 6 x 36 Class, FC or IWRC; IPS or XIP, XXIP. For other classes of wire rope not mentioned above, we recommend contacting Crosby Engineering.

**For Thimble Eye applications see the Crosby G-461 Thimble Eye Bundle Clip.**

**For OSHA (Construction) applications, see OSHA 1926.251.**

1. The eye of the sling must be in the choked position (around live line). Choker hitch applications should comply with the requirements of ASME B30.9 Slings. Install the choker hitch to provide a minimum choke angle of 120 degrees (See Figure 1). Refer to ASME B30.9 for required de-rating of the sling if choke angle is less than 120 degrees.

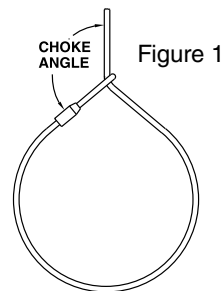

2. Before installing Bundle Clip, apply initial load by lifting the bundle and clearing the support, producing a tight choke. Repeat as necessary until the bundle package is in the most compact position (See figure 2, Loaded). **Keep hands and feet from under load.**

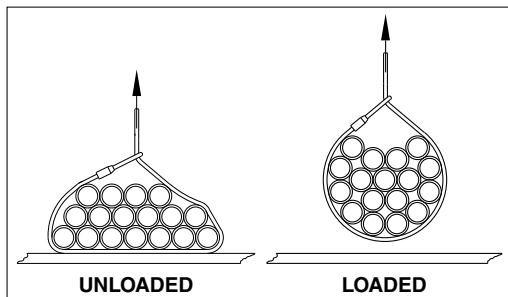

Figure 2

### WARNING

- Failure to read, understand, and follow these instructions may cause death or serious injury.
- A falling load may seriously injure or kill.
- Read and understand these instructions before using clips.
- Failure to properly position the Bundle Clip may allow the load to slip and fall.
- Do not use the Bundle Clip to form the choke hitch (See Figure 3).
- Match the same size clip to the same size wire rope.
- Install Bundle Clip only as instructed.
- Do not use with plastic coated wire rope.
- Do not use for lifting personnel.

3. After initial loading, install the Bundle Clip in proper orientation, with curved portion (Bundle Clip tip) over the eye of the sling. Insert U-bolt through the Bundle Clip. Properly position the clip base over the U-bolt and install nuts (See Figure 3). Use torque wrench to tighten evenly, alternating from one nut to the other until the curved portion bottoms out on the clip base, and the recommended torque is reached (See Table 1).

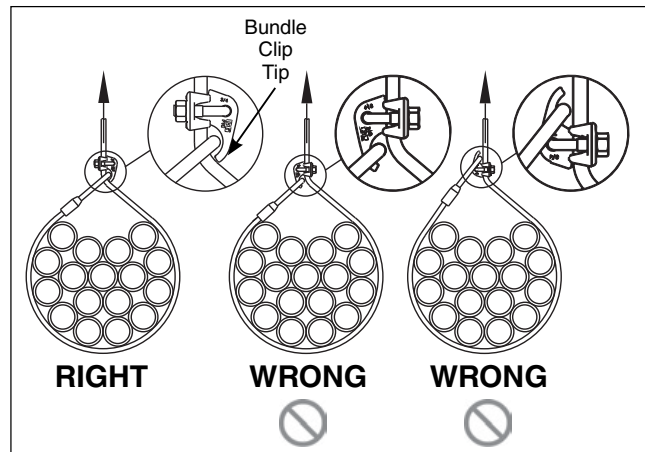

Figure 3

Table 1 – Recommended Torque

Clip Size	Rope Size (in)	Torque (ft•lbf)
5/8	5/8	95
3/4	3/4	130
7/8	7/8	225

4. Before each lift, check to ensure that the choke eye has not slipped from the Bundle Clip tip. Repeat Step 3 if necessary.

5. When disconnecting, the load should be clear of the stable support (See figure 2, Loaded). Remove Bundle Clip. Stay clear of the load as the bundle is lowered and the load is removed from the sling.

In accordance with good rigging and maintenance, the wire rope sling should be inspected periodically for wear, abuse, and general adequacy.

# CROSBY Slide-Loc® Lifting Point

## WARNINGS & APPLICATION INSTRUCTIONS



SL-150 & SL-150M  
Slide-Loc Lifting Point

### LIFTING POINT APPLICATION / ASSEMBLY INSTRUCTIONS

- Lifting Points incorporate a red indented area on each forged bail that provides a quick indicator to determine whether the Lifting Point is in the installation position or the lifting position. If the **QUIC-CHECK** mark is visible, product is in installation mode and shall not be used for lifting.
- To check**, look for indented surface (red) on bail. A visible **QUIC-CHECK** mark (Figure 2) means the slide lock and bolt are engaged for installation. When Lifting Point is properly installed, move slide lock to lifting position (Figure 1).
- Use Lifting Points only with a ferrous metal (i.e., steel, iron) or soft metal (e.g., aluminum) load (workpiece). Do not leave threaded end of Lifting Point in aluminum loads for long time periods due to corrosion.
- When using lifting slings of two or more legs, make sure the forces in the legs are calculated using the angle from the horizontal sling angle to the leg and select the proper size swivel hoist ring to allow for the angular forces.
- After determining the loads on each Lifting Point, select the proper size Lifting Point using the Working Load Limit ratings in Table 1 for UNC threads and Table 2 for Metric threads.
- Never exceed rated capacity of Lifting Point. See Table 1 for UNC threads, and Table 2 for metric threads.
- Drill and tap the workpiece to the correct size to a minimum depth of one-half the threaded shank diameter plus the threaded shank length.
- Install Lifting Point by hand so that the bushing flange is held tight to the mounting surface by the bolt. The bushing flange should engage the entire mounting surface.
- Never use spacers between bushing flange and mounting surface.
- Always select proper load rated lifting device for use with Lifting Points.
- Attach lifting device ensuring free fit to Lifting Point bail. (Figure 6)
- Never lift load if Red **QUIC-CHECK** indicator is visible. (Figure 2)
- Apply partial load and check proper rotation and alignment. The Lifting Point bail should be in-line with the direction of the load.



**WARNING**

- Load may slip or fall if proper Lifting Point assembly and lifting procedures are not used.
- A falling load can seriously injure or kill.
- Do not use with damaged slings or chain. For inspection criteria see ASME B30.9.
- Use only genuine Crosby bolts as replacements.
- Read and understand these warnings and application instructions.
- Do not load the Lifting Point if the slide lock is in the installation position (Red QUIC-CHECK mark is visible).

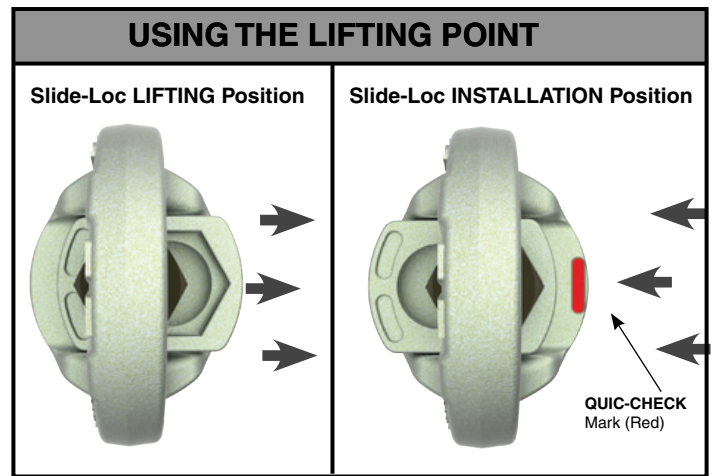

Figure 1

Figure 2

- Do not load in a direction perpendicular to the bail. (Figure 5)
- Special Note: When a Lifting Point is installed with a retention nut, the nut must have a full thread engagement and must meet one of the following standards to develop the Working Load Limit (WLL):

1. ASTM A-563
  - A. Grade D Hex Thick
  - B. Grade DH Standard Hex
2. SAE Grade 10.9 — Standard Hex

#### To place the Lifting Point:

- Move the slide lock into the installation position, such that the four flats on the bolt head are engaged. (Figure 2)
- Thread the bolt of the Lifting Point into the hole of your workpiece making sure that the entire length of exposed bolt thread is engaged. If the hole on your workpiece is not threaded, ensure that the Lifting Point is secured with a nut on the opposite side of your workpiece and that that nut thread is fully engaged.

Rigging  
Accessories



- Before applying any load, ensure that the slide lock has been moved back into the lifting position and that the bail is free to rotate. (Figure 1)
- The Lifting Point can be loaded in any direction shown in Figure 4.
- Do not swivel the Lifting Point while supporting a load. The Lifting Point is a positioning device and is not intended to swivel under load.

### To remove Lifting Point

- Move the slide lock into the installation position, such that the four flats on the bolt head flats are engaged. (Figure 2)
- Unthread the Lifting Point from your workpiece.

### Lifting Point Inspection / Maintenance

- Perform regular daily inspections as recommended.
- Always inspect Lifting Point before use.
- Regularly inspect Lifting Point parts. (Figure 3)
- Never use Lifting Point that shows signs of corrosion, wear or damage.
- Never use Lifting Point if bail is bent or elongated.
- Always be sure threads on shank and receiving hole are clean, not damaged, and fit properly.
- Never use spacers (washers) between bushing flange and the mounting surface.
- Always ensure free movement of bail. The bail should swivel 360 degrees. (Figure 3)
- Always be sure total workpiece surface is in contact with Lifting Point bushing mating surface. Drilled and tapped hole must be 90 degrees to load (workpiece) surface.

Working Load Limit 4:1 (t)	UNC Bolt Size (in)	Effective Thread Projection Length (in)
.5	3/8	.61
.75	1/2	.80
1.50	5/8	1.01
2.30	3/4	1.28
2.30	7/8	1.63
3.20	1	1.93

Working Load Limit 4:1 (t)	Metric Bolt Size (mm)	Effective Thread Projection Length (mm)
.5	10	14.7
.75	12	18.1
1.50	16	24.5
2.30	20	31.0
3.20	24	37.0

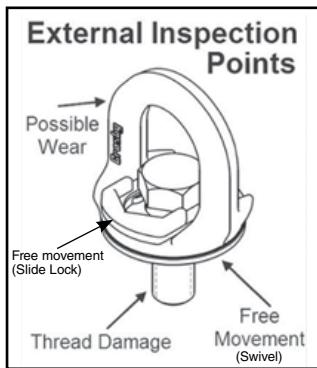

Figure 3

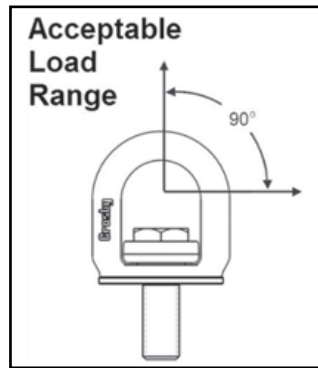

Figure 4

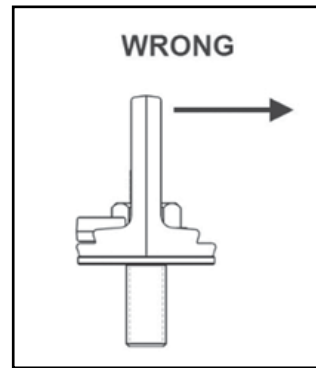

Figure 5

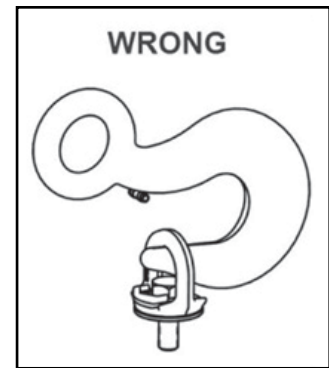
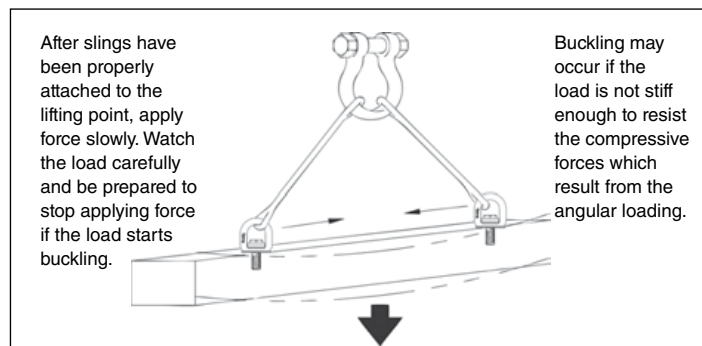
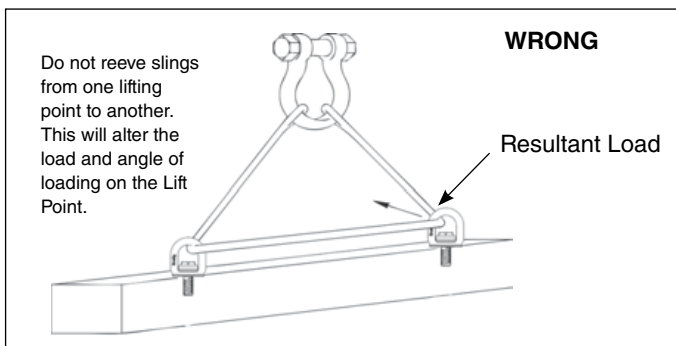

Figure 6





# CHAIN & ACCESSORIES

With Product Warning and Application Information



# CROSBY ELIMINATOR®

LOOK TO THE CROSBY PLATINUM LINE FOR PREMIUM SLING RIGGING



A-1361 shown with optional S-4104N Latch Pin.

A-1362 shown with optional S-4104N Latch Pin

## The Top ELIMINATOR Advantages Over The Competition

- RFID-equipped: No extra tag needed when using an electronic inspection system
- Crosby QUIC-CHECK® marks forged into the bail for quick and easy overload indication
- Optional S-4104N Latch Pin keeps the shortened chain in position when sling is removed from the crane hook temporarily
- Hinged design prevents bending when fitting is against a curved object
- The Crosby Eliminator® 2-piece design allows maximum flexibility; The same bail fits either the single or double hook
- Available in five sizes, 9/32" (7mm) through 5/8" (16mm)
- Wider and longer bail accommodates more hook sizes
- Only 2 fittings needed to build any adjustable sling, from single leg to quad
- Easy assembly of triple and quad chain slings
- Use the ELIMINATOR assembly with an oblong link to fit oversize hooks
- All Crosby ELIMINATOR® fittings are made in the U.S.A.

Crosby 8/10™ Fatigue Rated®



QUIC-CHECK®



Crosby®

## GENERAL INFORMATION

### WORKING LOAD LIMIT

The "Working Load Limit" is the maximum load in pounds which should ever be applied to chain, when the chain is new or in as-new condition, and when the load is uniformly applied in direct tension to a straight length of chain.

### PROOF TEST

The "Proof Test" is a term designating the tensile test applied to new chain for the sole purpose of detecting injurious defects in the material or manufacture. It is the load that the chain has withstood under a test in which the load has been applied in direct tension to a straight length of chain.

### MINIMUM ULTIMATE LOAD

The "Minimum Ultimate Load" is the minimum load at which new chain will break when tested by applying direct tension to a straight length of chain at a uniform rate of speed in a testing machine.

### ATTACHMENTS

Any attachments, such as hooks or links, should have a rated "Working Load Limit" at least equal to the chain with which it is used.

### SYMMETRICAL LOADING

Rated Working Load Limit assumes symmetrical loading of all sling legs.

### SPECIFICATIONS: ASME B30.9 2006

Paragraph 9-1.6.1 "Prior to initial use, all new and repaired chain and components of an alloy steel chain sling, either individually or as an assembly, shall be proof tested by the sling manufacturer or qualified person.



## CAUTION

Only Crosby Alloy chain, Spectrum 8® or Spectrum 10®, should be used for overhead lifting applications.

**General Usage** – It must be recognized that certain factors in the usage of chain and attachments can be abusive and lessen the load that the chain or attachments can withstand. Some examples are twisting of the chain; disfigurement; deterioration by straining, usage, weathering and corrosion; rapid application of load or jerking; applying excessive loads; sharp corner cutting action and non-symmetrical loading effects.

When using chain slings in choker applications, the Working Load Limit must be reduced by 20%. Crosby recommends a minimum angle of choke of 120 degrees. Consult Crosby when planning to use an angle of choke of less than 120 degrees. If Crosby A-1338 cradle grab hooks are used at a minimum angle of choke of 120 degrees, the full sling rated WLL can be utilized.



In shortening applications, a 20% reduction of the Working Load Limit is required except when using the Crosby A-1338 Cradle Grab Hooks, S-1311 Chain Shortener Link, the A-1355 Chain Choker Hook in conjunction with the S-1325 Chain Coupler Link, or the Crosby ELIMINATOR® shortener link. They can be used without any reduction to the Working Load Limit.

Care should be taken to observe these derated applications or chain may fracture or permanently stretch at loads less than the advertised chain ultimate strength and proof load respectively.

**Environmental Effects** – Excessive high or low temperatures, or exposure to chemically active environments such as acids or corrosive liquids or fumes, can reduce the performance of the chain.

### Temperature

- Extreme temperatures will reduce the performance of alloy steel chain slings.
- Normal operating temperature is -40° F to 400° F (-40° C to 204° C).

- See the temperature exposure chart (Table 1) to determine reduction of WLL due to operation at, and exposure to, elevated temperatures.

**Chemically Active Environments** can have detrimental effects on the performance of chain. The effects can be both visible loss of material and undetectable material degradation causing significant loss of strength.

- Usage Exposure – Exposure to chemically active environments such as acids or corrosive liquids or fumes can reduce the performance of the chain.
- Special Surface Coating/Plating/Galvanizing – Chain should not be subjected to galvanizing, or any plating process.
- If it is suspected that the chain has been exposed to chemically active environment, remove from service.

Temperature of Chain		Grade 8 (80) Chain		Grade 10 (100) Chain	
(F°)	(C°)	Temporary Reduction of Rated Load at Elevated Temperature*	Permanent Reduction of Rated Load After Exposure to Temperature**	Temporary Reduction of Rated Load at Elevated Temperature*	Permanent Reduction of Rated Load After Exposure to Temperature**
Below 400	Below 204	None	None	None	None
400	204	10%	None	15%	None
500	260	15%	None	25%	5%
600	316	20%	5%	30%	15%
700	371	30%	10%	40%	20%
800	427	40%	15%	50%	25%
900	482	50%	20%	60%	30%
1000	538	60%	25%	70%	35%
Over 1000	Over 538	OSHA 1910.184 and ASME B30.9 requires all slings exposed to temperatures over 1000° F to be removed from service.			

\* Crosby does not recommend the use of Alloy Chain at temperatures above 800° F.

\*\* When chain is used at room temperature after being heated to temperatures shown in the first column



# Crosby® Grade 100 Chain Sling Configurations

## TO MAKE YOUR CROSBY® GRADE 100 ALLOY CHAIN SLING

Follow these simple steps in making a sling assembly:

1. Determine the maximum load to be lifted by the sling assembly.
2. Choose the type of sling assembly suited for the shape of the load and the size of the sling assembly for the load to be lifted. The decision must take into account the angle of the sling legs in multileg slings.
3. Determine the overall reach from bearing point of master link to bearing point on hook (see Fig. 1).
4. Select components, assemble chain and components.
5. Affix sling identification tag to sling. The tag is available from your Authorized Crosby Distributor.

Each sling shall be marked to show: name or trademark of manufacturer, grade, nominal chain size, number of legs, rated load for the type(s) of hitch(es) used and angle upon which it is based (reach).

If measurement comes in the link, cut the following link. For two leg type slings, count the links and use an even number for clevis

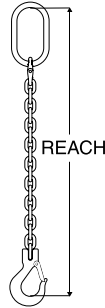

hooks and an odd number for eye hooks. This will position hooks in the same plane. In multileg slings always use the same number of links in each leg.

When using chain slings in choker applications, the Working Load Limit must be reduced by 20%. Crosby recommends a minimum angle of choke of 120 degrees. Consult Crosby when planning to use an angle of choke of less than 120 degrees. If Crosby A-1338 cradle grab hooks are used at a minimum angle of choke of 120 degrees, the full sling rated WLL can be utilized.



In shortening applications, a 20% reduction of the Working Load Limit is required except when using the Crosby A-1338 Cradle Grab Hooks, S-1311 Chain Shortener Link, the A-1355 Chain Choker Hook in conjunction with the S-1325 Chain Coupler Link, or the Crosby ELIMINATOR® shortener link. They can be used without any reduction to the Working Load Limit.



The Slings shown here are standard assemblies that can be made from "Proof Tested" Crosby Components and Alloy Chain supplied by your authorized Crosby distributor. Assemblies must include chain sling identification tag (not shown, see page 238).



TYPE CO    TYPE SOS    TYPE SOG    TYPE SOF    TYPE SSS    TYPE SGS    TYPE ASOS    TYPE ASOF    TYPE ASOG    TYPE SOCH

Type	Description	Type	Description
CO	Single Chain Sling with Master Link each end	SGS	Single Chain Sling with Grab Hook and Sling Hook
SOS	Single Chain Sling with Master Link and Sling Hook	ASOS	Adjustable Single Chain with Master Link and Sling Hook
SOG	Single Chain Sling with Master Link and Grab Hook	ASOF	Adjustable Single Chain Sling with Master Link and Foundry Hook
SOF	Single Chain Sling with Master Link and Foundry Hook	ASOG	Adjustable Single Chain Sling with Master Link and Grab Hook
SSS	Single Chain Sling with Sling Hook each end	SOCH	Single with 1355 Choker

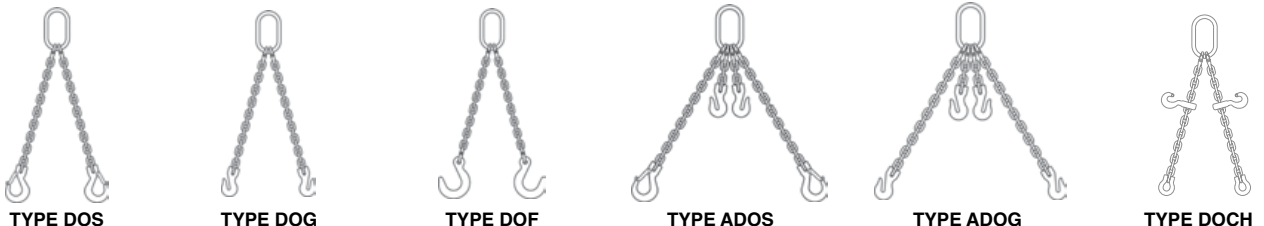

TYPE DOS    TYPE DOG    TYPE DOF    TYPE ADOS    TYPE ADOG    TYPE DOCH

Type	Description	Type	Description
DOS	Double Chain Sling with Master Link and Sling Hook	ADOS	Adjustable Double Chain Sling with Master Link and Sling Hook
DOG	Double Chain Sling with Master Link and Grab Hook	ADOG	Adjustable Double Chain Sling with Master Link and Grab Hook
DOF	Double Chain Sling with Master Link and Foundry Hook	DOCH	Double with 1355 Choker

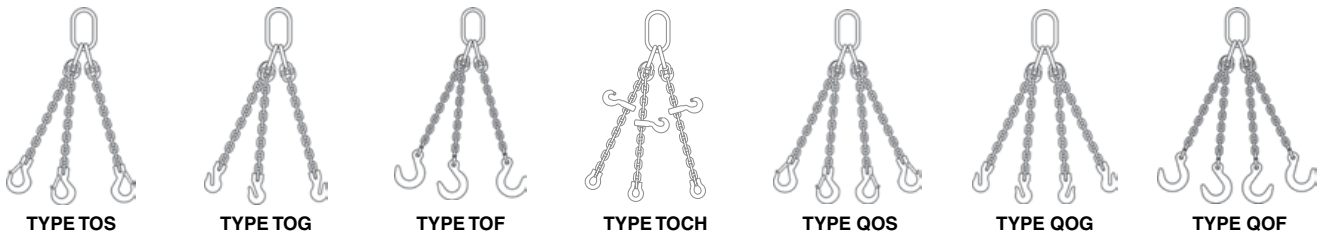

TYPE TOS    TYPE TOG    TYPE TOF    TYPE TOCH    TYPE QOS    TYPE QOG    TYPE QOF

Type	Description	Type	Description
TOS	Triple Chain Sling with Master Link and Sling Hook	QOS	Quadruple Chain Sling with Master Link and Sling Hook
TOG	Triple Chain Sling with Master Link and Grab Hook	QOG	Quadruple Chain Sling with Master Link and Grab Hook
TOF	Triple Chain Sling with Master Link and Foundry Hook	QOF	Quadruple Chain Sling with Master Link and Foundry Hook
TOCH	Triple with 1355 Choker		

## TO ORDER YOUR CROSBY ELIMINATOR® GRADE 100 ALLOY CHAIN SLING

Follow these simple steps to order a sling assembly:

1. Determine the maximum load to be lifted by the sling assembly.
2. Choose the type of sling assembly suited for the shape of the load and the size of the sling assembly for the load to be lifted. The decision must take into account the angle of the sling legs in multileg slings.
3. Determine the overall reach from bearing point of Eliminator Bail to bearing point on hook (see Fig. 1).
4. Select components, assemble chain and components.
5. Affix sling identification tag to sling. The tag is available from your Authorized Crosby Distributor.



Fig. 1

When using chain slings in choker applications, the Working Load Limit must be reduced by 20%. Crosby recommends a minimum angle of choke of 120 degrees.

Consult Crosby when planning to use an angle of choke of less than 120 degrees. If Crosby A-1338 cradle grab hooks are used at a minimum angle of choke of 120 degrees, the full sling rated WLL can be utilized.



In shortening applications, a 20% reduction of the Working Load Limit is required except when using the Crosby A-1338 Cradle Grab Hooks, S-1311 Chain Shortener Link, the A-1355 Chain Choker Hook in conjunction with the S-1325 Chain Coupler Link, or the Crosby ELIMINATOR® shortener link. They can be used without any reduction to the Working Load Limit.

Each sling shall be marked to show: name or trademark of manufacturer, grade, nominal chain size, number of legs, rated load for the type(s) of hitch(es) used and angle upon which it is based (reach).



TYPE ESO



TYPE ESOS



TYPE ESOG



TYPE ESOL



TYPE ESOF

Type	Description	Type	Description
ESOS	Crosby ELIMINATOR® Single Chain Sling with Sling Hook	ESOL	Crosby ELIMINATOR® Single Chain with SHUR-LOC® Hook
ESOG	Crosby ELIMINATOR® Single Chain Sling with Grab Hook	ESOF	Crosby ELIMINATOR® Single Chain with Foundry Hook



TYPE EDO



TYPE EDOS



TYPE EDOG



TYPE EDOL



TYPE EDOF

Type	Description	Type	Description
EDOS	Crosby ELIMINATOR® Double Chain Sling with Sling Hooks	EDOL	Crosby ELIMINATOR® Double Chain with SHUR-LOC® Hooks
EDOG	Crosby ELIMINATOR® Double Chain Sling with Grab Hooks	EDOF	Crosby ELIMINATOR® Double Chain with Foundry Hooks



TYPE ETOS



TYPE ETOG



TYPE ETOL



TYPE ETOF



TYPE EQOS



TYPE EQOG



TYPE EQOL



TYPE EQOF

Type	Description	Type	Description
ETOS	Crosby ELIMINATOR® Triple Chain Sling with Master Link and Sling Hooks	EQOS	Crosby ELIMINATOR® Quad Chain Sling with Master Link and Sling Hooks
ETOG	Crosby ELIMINATOR® Triple Chain Sling with Master Link and Grab Hooks	EQOG	Crosby ELIMINATOR® Quad Chain Sling with Master Link and Grab Hooks
ETOL	Crosby ELIMINATOR® Triple Chain Sling with Master Link and SHUR-LOC® Hooks	EQOL	Crosby ELIMINATOR® Quad Chain Sling with Master Link and SHUR-LOC® Hooks
ETOF	Crosby ELIMINATOR® Triple Chain Sling with Master Link and Foundry Hooks	EQOF	Crosby ELIMINATOR® Quad Chain Sling with Master Link and Foundry Hooks



# Grade 100 Assembly Chart

## SINGLE LEG SLING

Spectrum 10 <sup>®</sup> Chain Size													
(in)	(mm)	Grade 100 Chain Stock No.	Master Link A-1342N Stock No.	Master Link Assembly A-1345N Stock No.	Master Link A-342 Stock No.	Master Link A-345 Stock No.	ELIMINATOR L-1361 Stock No.	LOK-A-LOY <sup>®</sup> A-1337 Stock No.	Chain Coupler S-1325A Stock No.	Chain Shortener Link S-1311N Stock No.	SHUR-LOC <sup>®</sup> Clevis Hook S-1317 Stock No.	SHUR-LOC <sup>®</sup> Eye Hook S-1316 Stock No.	SHUR-LOC <sup>®</sup> Swivel Hook S-1326 Stock No.
1/4 (9/32)	7	273710	1011403X1	—	1014266	—	1049802	1015104	1098500	1017869	1029000	1022914	1004313
5/16	8	273729	1011412X2	—	1014266 1014280 1014285	—	1049809	1015113	1098504	1017878	1029009	1022914	1004313
3/8	10	273738	1011421X3	—	1014285 1014319	—	1049818	1015122	1098508	1017897	1029018	1002923	1004323
1/2	13	273747	1011430X4	—	1014319 1014331	—	1049827	1015136	1098512	1017906	1029027	1002932	1004331
5/8	16	273756	1011449X5	—	1014331 1014348	—	1049836	1015145	1098516	1017915	1029036	1002941	1004340
3/4	20	273858	1011458X6	—	1014348 1014365	—	—	1015154	—	—	1021071	1022942	1004349
7/8	22-23	273867	1011467X7	—	1014365 1014388	—	—	1015163	—	—	1029080	1022943	1004358
1	26	273876	—	—	1014388 1014404	—	—	1015172	—	—	1029089	1022944	—
1-1/4	32	—	—	—	1014404 1014422	—	—	1015181	—	—	—	—	—

## DOUBLE LEG SLING

Spectrum 10 <sup>®</sup> Chain Size		Grade 100 Chain Stock No.	Master Link A-1342N Stock No.	Master Link Assembly A-1345N Stock No.	Master Link A-342 Stock No.	Master Link A-345 Stock No.	ELIMINATOR L-1362 Stock No.	LOK-A-LOY <sup>®</sup> A-1337 Stock No.	Chain Coupler S-1325A Stock No.	Chain Shortener Link S-1311N Stock No.	SHUR-LOC <sup>®</sup> Clevis Hook S-1317 Stock No.	SHUR-LOC <sup>®</sup> Eye Hook S-1316 Stock No.	SHUR-LOC <sup>®</sup> Swivel Hook S-1326 Stock No.
(in)	(mm)	Grade 100 Chain Stock No.	Master Link A-1342N Stock No.	Master Link Assembly A-1345N Stock No.	Master Link A-342 Stock No.	Master Link A-345 Stock No.	ELIMINATOR L-1362 Stock No.	LOK-A-LOY <sup>®</sup> A-1337 Stock No.	Chain Coupler S-1325A Stock No.	Chain Shortener Link S-1311N Stock No.	SHUR-LOC <sup>®</sup> Clevis Hook S-1317 Stock No.	SHUR-LOC <sup>®</sup> Eye Hook S-1316 Stock No.	SHUR-LOC <sup>®</sup> Swivel Hook S-1326 Stock No.
1/4 (9/32)	7	273710	1011403X1	—	1014266	—	1049913	1015104	1098500	1017869	1029000	1022914	1004313
5/16	8	273729	1011412X2	—	1014285	—	1049922	1015113	1098504	1017878	1029009	1022914	1004313
3/8	10	273738	1011421X3	—	1014319	—	1049931	1015122	1098508	1017897	1029018	1002923	1004323
1/2	13	273747	1011430X4	—	1014331	—	1049940	1015136	1098512	1017906	1029027	1002932	1004331
5/8	16	273756	1011449X5	—	1014348	—	1049949	1015145	1098516	1017915	1029036	1002941	1004340
3/4	20	273858	1011458X6	—	1014365	—	—	1015154	—	—	1021071	1022942	1004349
7/8	22-23	273867	1011467X7	—	1014388	—	—	1015163	—	—	1029080	1022943	1004358
1	26	273876	—	—	1014404	—	—	1015172	—	—	1029089	1022944	—
1-1/4	32	—	—	—	1014468	—	—	1015181	—	—	—	—	—

## TRIPLE AND QUAD LEG SLINGS

Spectrum 10 <sup>®</sup> Chain Size		Grade 100 Chain Stock No.	Master Link A-1342N Stock No.	Master Link Assembly A-1345N Stock No.	Master Link A-342 Stock No.	Master Link A-345 Stock No.	ELIMINATOR Stock No.	LOK-A-LOY <sup>®</sup> A-1337 Stock No.	Chain Coupler S-1325A Stock No.	Chain Shortener Link S-1311N Stock No.	SHUR-LOC <sup>®</sup> Clevis Hook S-1317 Stock No.	SHUR-LOC <sup>®</sup> Eye Hook S-1316 Stock No.	SHUR-LOC <sup>®</sup> Swivel Hook S-1326 Stock No.
(in)	(mm)	Grade 100 Chain Stock No.	Master Link A-1342N Stock No.	Master Link Assembly A-1345N Stock No.	Master Link A-342 Stock No.	Master Link A-345 Stock No.	ELIMINATOR Stock No.	LOK-A-LOY <sup>®</sup> A-1337 Stock No.	Chain Coupler S-1325A Stock No.	Chain Shortener Link S-1311N Stock No.	SHUR-LOC <sup>®</sup> Clevis Hook S-1317 Stock No.	SHUR-LOC <sup>®</sup> Eye Hook S-1316 Stock No.	SHUR-LOC <sup>®</sup> Swivel Hook S-1326 Stock No.
1/4 (9/32)	7	273710	—	1011510	—	1014739	See Page 225	1015104	1098500	1017869	1029000	1022914	1004313
5/16	8	273729	—	1011510	—	1014742		1015113	1098504	1017878	1029009	1022914	1004313
3/8	10	273738	—	1011529	—	1014766		1015122	1098508	1017897	1029018	1002923	1004323
1/2	13	273747	—	1011538	—	1014779		1015136	1098512	1017906	1029027	1002932	1004331
5/8	16	273756	—	1011547	—	1014807		1015145	1098516	1017915	1029036	1002941	1004340
3/4	20	273858	—	1011556	—	1014810		1015154	—	—	1021071	1022942	1004349
7/8	22-23	273867	—	1011565	—	1014845		1015163	—	—	1029080	1022943	1004358
1	26	273876	—	—	—	1014845		1015172	—	—	1029089	1022944	—
1-1/4	32	—	—	—	—	1014986		1015181	—	—	—	—	—

## SINGLE LEG SLING

Spectrum 10 <sup>®</sup> Chain Size										
(in)	(mm)	SHUR-LOC <sup>®</sup> Swivel Hook w/ Bearing S-13326 Stock No.	Clevis Sling Hook L-1339 Stock No.	Eye Sling Hook L-1327 Stock No.	Cradle Grab Hook A-1338* Stock No.	Clevis Grab Hook A-1358* Stock No.	Eye Grab Hook A-1328 Stock No.	Clevis Foundry Hook A-1359 Stock No.	Eye Foundry Hook A-1329 Stock No.	Chain Choker A-1355 Stock No.
1/4 (9/32)	7	1004413	1049112	1025869	1049417	1049610	1026169	1049907	1026280	1015204
5/16	8	1004413	1049121	1025869	1049426	1049629	1026169	1049911	1026280	1015204
3/8	10	1004422	1049130	1025878	1049435	1049638	1026187	1049916	1026289	1015213
1/2	13	1004431	1049149	1025887	1049444	1049647	1026196	1049925	1026297	1015222
5/8	16	1004440	1049158	1025896	1049453	1049656	1026205	1049934	1026306	1015231
3/4	20	—	1049167	1025915	—	—	1026214	1049943	1026315	—
7/8	22-23	—	1049176	1025924	—	—	1026223	1049952	1026324	—
1	26	—	—	1025933	—	—	1016232	—	1026333	—
1-1/4	32	—	—	1025942	—	—	1026241	—	1026342	—

## DOUBLE LEG SLING

Spectrum 10 <sup>®</sup> Chain Size		SHUR-LOC <sup>®</sup> Swivel Hook w/ Bearing S-13326 Stock No.	Clevis Sling Hook A-1339 * Stock No.	Eye Sling Hook L-1327 Stock No.	Cradle Grab Hook A-1338* Stock No.	Clevis Grab Hook A-1358* Stock No.	Eye Grab Hook A-1328 Stock No.	Clevis Foundry Hook A-1359 Stock No.	Eye Foundry Hook A-1329 Stock No.	Chain Choker A-1355 Stock No.
(in)	(mm)	SHUR-LOC <sup>®</sup> Swivel Hook w/ Bearing S-13326 Stock No.	Clevis Sling Hook A-1339 * Stock No.	Eye Sling Hook L-1327 Stock No.	Cradle Grab Hook A-1338* Stock No.	Clevis Grab Hook A-1358* Stock No.	Eye Grab Hook A-1328 Stock No.	Clevis Foundry Hook A-1359 Stock No.	Eye Foundry Hook A-1329 Stock No.	Chain Choker A-1355 Stock No.
1/4 (9/32)	7	1004413	1048991	1025869	1049417	1049610	1026169	1049907	1026280	1015204
5/16	8	1004413	1049000	1025869	1049426	1049629	1026169	1049911	1026280	1015204
3/8	10	1004422	1049009	1025878	1049435	1049638	1026187	1049916	1026289	1015213
1/2	13	1004431	1049018	1025887	1049444	1049647	1026196	1049925	1026297	1015222
5/8	16	1004440	1049027	1025896	1049453	1049656	1026205	1049934	1026306	1015231
3/4	20	—	1049036	1025915	—	—	1026214	1049943	1026315	—
7/8	22-23	—	1049045	1025924	—	—	1026223	1049952	1026324	—
1	26	—	—	1025933	—	—	1026232	—	1026333	—
1-1/4	32	—	—	1025942	—	—	1026241	—	1026342	—

Chain & Accessories

## TRIPLE AND QUAD LEG SLINGS

Spectrum 10 <sup>®</sup> Chain Size		SHUR-LOC <sup>®</sup> Swivel Hook w/ Bearing S-13326 Stock No.	Clevis Sling Hook A-1339 * Stock No.	Eye Sling Hook L-1327 Stock No.	Cradle Grab Hook A-1338* Stock No.	Clevis Grab Hook A-1358* Stock No.	Eye Grab Hook A-1328 Stock No.	Clevis Foundry Hook A-1359 Stock No.	Eye Foundry Hook A-1329 Stock No.	Chain Choker A-1355 Stock No.
(in)	(mm)	SHUR-LOC <sup>®</sup> Swivel Hook w/ Bearing S-13326 Stock No.	Clevis Sling Hook A-1339 * Stock No.	Eye Sling Hook L-1327 Stock No.	Cradle Grab Hook A-1338* Stock No.	Clevis Grab Hook A-1358* Stock No.	Eye Grab Hook A-1328 Stock No.	Clevis Foundry Hook A-1359 Stock No.	Eye Foundry Hook A-1329 Stock No.	Chain Choker A-1355 Stock No.
1/4 (9/32)	7	1004413	1048991	1025869	1049417	1049610	1026169	1049907	1026280	1015204
5/16	8	1004413	1049000	1025869	1049426	1049629	1026169	1049911	1026280	1015204
3/8	10	1004422	1049009	1025878	1049435	1049638	1026187	1049916	1026289	1015213
1/2	13	1004431	1049018	1025887	1049444	1049647	1026196	1049925	1026297	1015222
5/8	16	1004440	1049027	1025896	1049453	1049656	1026205	1049934	1026306	1015231
3/4	20	—	1049036	1025915	—	—	1026214	1049943	1026315	—
7/8	22-23	—	1049045	1025924	—	—	1026223	1049952	1026324	—
1	26	—	—	1025933	—	—	1026232	—	1026333	—
1-1/4	32	—	—	1025942	—	—	1026241	—	1026342	—

\* Available in latch version.



## WORKING LOAD LIMIT – 4 TO 1 DESIGN FACTOR

Chain Size		90°	60°	45°	30°	60°	45°	30°
(in)	(mm)	Single Leg	Double Leg			Triple and Quad Leg		
—	6	3200	5500	4500	3200	8300	6800	4800
1/4 (9/32)	7	4300	7400	6100	4300	11200	9100	6400
5/16	8	5700	9900	8100	5700	14800	12100	8500
3/8	10	8800	15200	12400	8800	22900	18700	13200
1/2	13	15000	26000	21200	15000	39000	31800	22500
5/8	16	22600	39100	32000	22600	58700	47900	33900
3/4	20	35300	61100	49900	35300	91700	74900	52950
7/8	22	42700	74000	60400	42700	110900	90600	64000
1	26	59700	103400	84400	59700	155100	126600	89550
1-1/4	32	90400	156600	127800	90400	234900	191700	135600

For choker applications, the Working Load Limit must be reduced by 20%. The Crosby A-1338 cradle grab hook and S1311N chain shorter link do not require any reduction of the Working Load Limit. The design factor of 4 to 1 on Spectrum® 10 Alloy Chain agrees with the design factor used by the International Standards Organization (I.S.O.) and ASME B30.9 and is the preferred set of Working Load Limit values to be used.

# Crosby ELIMINATOR Fittings



**A-1361**  
Single Hook

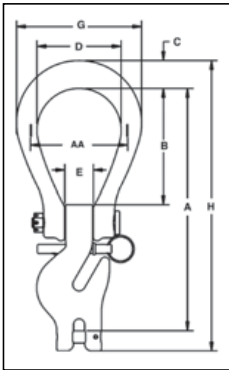

The Crosby ELIMINATOR® combines selected features and functionality of a master link, connecting link, grab hook and adjuster legs to provide you with one fitting that is suitable for applications that require an adjustable length chain sling.

- Forged Alloy Steel - Quenched and Tempered.
- Innovative two piece design allows for maximum flexibility.
- Individually Proof Tested with certification.
- The Crosby ELIMINATOR®, with properly installed and locked latch pin, can be used for personnel lifting applications and meets the intent of OSHA Rule 1926.1431(g)(1)(i) (A) and 1926.1501(g)(4)(iv)(B).
- Suitable for use with Grade 100 and Grade 80 chain.
- Engineered to accommodate optional locking pins that can be inserted to “lock” the shortened chain legs into place.
- Fatigue rated at 1-1/2 times the Working Load Limit at 20,000 cycles.
- Use the A-1361 and A-1362 in combination to make 3 leg chain slings.
- Load pin assembly instructions on page 276.
- “Look for the Platinum Color - Crosby Grade 100 Alloy Products.”
- All sizes are RFID EQUIPPED.



**A-1362**  
Double Hook

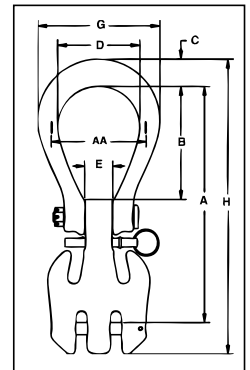

**Crosby 8/10™**



**Fatigue Rated®**



Chain & Accessories

## A-1361 Crosby ELIMINATOR® Single Hook

Chain Size		Frame Size	Working Load Limit (lb)*	A-1361 Stock No.	L-1361 Stock No.	Weight Each (lb)	Dimensions (in)								S-4104N Replacement Latch Pin Stock No.
(in)	(mm)						A	B	C	D	E	G	H	AA	
1/4	7	2	4300	1049797	1049802	3.9	8.20	3.88	.90	3.00	.94	4.40	9.78	3.50	1092983
5/16	8	2	5700	1049804	1049809	3.9	8.18	3.88	.90	3.00	.94	4.40	9.78	3.50	1092983
3/8	10	3	8800	1049813	1049818	6.5	10.05	4.81	1.16	3.50	1.13	5.20	12.06	4.00	1092992
1/2	13	4	15000	1049822	1049827	13.5	12.88	6.00	1.63	4.13	1.31	6.39	15.57	5.00	1093001
5/8	16	5	22600	1049831	1049836	24.1	15.26	6.88	1.96	4.75	1.63	7.41	18.58	6.00	1093010

\* Proof tested at 2.5 times the Working Load Limit. Minimum Ultimate Load is 4 times the Working Load Limit.

## A-1362 Crosby ELIMINATOR® Double Hook

Chain Size		Frame Size	Working Load Limit (lb)*	A-1362 Stock No.	L-1362 Stock No.	Weight Each (lb)	Dimensions (in)								S-4104N Replacement Latch Pin Stock No.
(in)	(mm)						A	B	C	D	E	G	H	AA	
1/4	7	2	8600	1049859	1049913	4.7	8.20	3.88	.90	3.00	.94	4.40	10.10	3.50	1092983
5/16	8	2	11400	1049868	1049922	4.7	8.18	3.88	.90	3.00	.94	4.40	10.10	3.50	1092983
3/8	10	3	17600	1049877	1049931	8.1	10.05	4.81	1.16	3.50	1.13	5.20	12.56	4.00	1092992
1/2	13	4	30000	1049886	1049940	17.3	12.88	6.00	1.63	4.13	1.31	6.39	16.25	5.00	1093001
5/8	16	5	45200	1049895	1049949	31.5	15.26	6.88	1.96	4.75	1.63	7.41	19.33	6.00	1093010

\* Proof tested at 2 times the Working Load Limit. Minimum Ultimate Load is 4 times the Working Load Limit.

## Using Crosby ELIMINATOR® in 3 and 4 Leg Slings

See page 222-223 for basic chain sling components.

Spectrum 10 Chain Size		Master Link A-342 Stock No.	Master Link A-1342 Stock No.	Crosby ELIMINATOR® Single A-1361 Stock No.	Crosby ELIMINATOR® Double A-1362 Stock No.
(in)	(mm)				
1/4 (9/32)	7	1014285	1011412	1049797	1049859
5/16	8	1014319	1011421	1049804	1049868
3/8	10	1014331	1011430	1049813	1049877
1/2	13	1014348	1011449	1049822	1049886
5/8	16	1014365	1011458	1049831	1049895

Use one of either A-342 or A-1342 master link.  
Use one of each when making three leg sling.

Spectrum 10 Chain Size		Master Link A-342 Stock No.	Master Link A-1342 Stock No.	Crosby ELIMINATOR® Single A-1361 Stock No.	Crosby ELIMINATOR® Double A-1362 Stock No.
(in)	(mm)				
1/4 (9/32)	7	1014285	1011412	–	1049859
5/16	8	1014319	1011421	–	1049868
3/8	10	1014331	1011430	–	1049877
1/2	13	1014348	1011449	–	1049886
5/8	16	1014365	1011458	–	1049895

Use one of either A-342 or A-1342 master link.  
Use two A-1362 fittings when making quad leg sling.



# Make Sure Crosby is on Your Lifting Team.

## WHO MADE YOUR MASTER LINK?

It's More Than a Certification; Know Who's Standing Behind You.

- As a critical part of your sling set assembly, it is important to know who manufactures and stands behind your Master Links.
- When you buy Crosby Master Links you lift with Crosby by your side.
- Crosby's name on your certification
- Full range of welded and forged Master Links manufactured by Crosby and sold through authorized distributors.
- Working through your Authorized Distributor, you are never more than one step away from Crosby, which ensures accountability, confidence and support
  - More rigging experts closer to the point of use than any other rigging hardware manufacturer.
  - Access to world class training.
  - Legendary performance and durability.
  - Crosby is more than just a manufacturer, we are part of your lifting team.

"Master Links are the "most" critical part of your sling set assembly, using Crosby links was always reassuring."

- Jim McClellon  
Technical Authority Lifting, Shell E&P  
(Retired)



**A-1346**  
Welded Master Links  
with Engineered Flat

### CROSBY LINKS OFFER:

- DNV Type approval directly from Crosby.
  - An Industry leading 5/1 safety factor.
- DNV Certification Note 2.7-1 Offshore Containers, 100% proof tested, MPI and impact tested.
- Large inside width and length to allow additional room for sling hardware and crane hook.
- Engineered flat top better suit thimbles and other fittings
- A larger opening for easier and faster rigging connections.

# Crosby

[thecrosbygroup.com](http://thecrosbygroup.com)

**"QT"**  
QUENCHED & TEMPERED

# Grade 100 Alloy Chain



**Spectrum® 10**  
Grade 100  
Alloy Chain

- Alloy Steel.
- Heat Treated.
- 25% stronger than Grade 80 Alloy Chain.
- Permanently embossed with CG (Crosby Group) and 10 (Grade).
- Finish - Black rust preventative coating.
- Proof Tested at 2 times the Working Load Limit with certification
- Standard container - fiber drum

## Grade 100 Alloy Chain Recommended for overhead lifting applications

Chain Size		Gr. 100 Drum Stock No.	Feet Per Drum	Material Size (in)	Working Load Limit (lb)*	Maximum Inside Length (in)	Maximum Inside Width (in)	Maximum Length 100 Links (in)	Weight Per 100 Feet (lb)
(in)	(mm)								
9/32 (1/4)	7	273710	500	.276	4300	.87	.42	90	75
5/16	8	273729	500	.343	5700	1.01	.49	100	113
3/8	10	273738	500	.394	8800	1.23	.58	125	148
1/2	13	273747	300	.512	15000	1.57	.77	164	249
5/8	16	273756	200	.630	22600	1.93	.90	202	378
3/4	20	273858	100	.787	35300	2.52	.98	252	590
7/8	22	273867	100	.866	42700	2.77	1.08	277	740
1	26	273876	75	1.02	59700	3.28	1.28	328	1010

\* Proof tested at 2 times Working Load Limit. Ultimate Load is 4 times the Working Load Limit.

Chain & Accessories



**A-1337**  
10 Alloy  
Connecting Link

- Suitable for use with both Grade 80 and Grade 100 chain.
- Individually Proof Tested at 2-1/2 times Working Load Limit with certification.
- Locking system that provides for simple assembly and disassembly - no special tools needed.
- 25% stronger than Grade 80.
- Meets ASTM A-952 standards for Grade 100 chain fittings.
- Forged Alloy Steel - Quenched and Tempered.
- Sizes 9/32 through 1 inch are fatigue rated.
- "Look for the Platinum Color-Crosby Grade 100 Alloy Products."

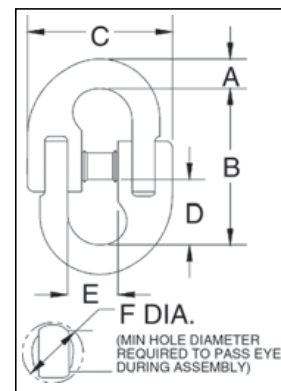

**Grosby 8/10™**



**Fatigue Rated**

## LOK-A-LOY® 10 Alloy Connecting Link

Chain Size		A-1337 Stock No.	Pkg. Qty.	Weight Each (lb)	Working Load Limit (lb)*	Dimensions (in)					
(in)	(mm)					A	B	C	D	E	F
9/32 (1/4)	7	1015104	60	.26	4300	.38	1.94	1.90	.81	.69	.57
5/16	8	1015113	50	.35	5700	.37	2.35	2.07	.99	.72	.64
3/8	10	1015122	40	.75	8800	.48	2.70	2.47	1.12	.90	.78
1/2	13	1015136	12	1.60	15000	.68	3.45	3.31	1.44	1.12	.97
5/8	16	1015145	10	2.68	22600	.81	4.13	3.90	1.72	1.35	1.14
3/4	20	1015154	1	5.00	35300	.93	4.62	4.62	2.03	1.62	1.28
7/8	22	1015163	1	7.50	42700	1.06	5.46	5.46	2.27	2.00	1.49
1	25	1015172	1	11.03	59700	1.22	5.98	6.13	2.44	2.25	1.76
1-1/4	32	1015181	1	20.38	90400	1.50	7.43	7.59	3.07	2.56	2.23

\*Ultimate Load is 4 times the Working Load Limit. For Grade 6 LOK-A-LOY®, see page 252.



## Grade 100 Alloy Master Links



**A-1342N**  
Master Link

- Alloy Steel - Quenched and Tempered.
- Individually proof tested to values shown with certification
- Proof tested with fixture sized to prevent localized point loading per ASTM A952.
- Proof test certification shipped with each link.
- All sizes are forged unless otherwise specified
- "Look for the Platinum Color - Crosby Grade 100 Alloy Products."
- Engineered Flat for use with S-1325A coupler link.

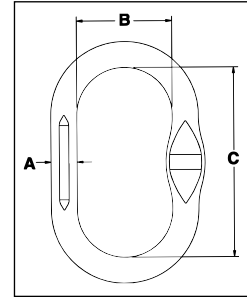

### A-1342N Master Link

A-1342N Designation Marking	A-1342N Stock No.	Grade 100 Chain Size		Working Load Limit (lb)*	Proof Load (lb)	Weight Each (lb)	Dimensions (in)		
		(in)	(mm)				A	B	C
X 1	1011403	1/4	6 - 7	8600	17200	1.1	.60	2.50	5.00
X 2	1011412	5/16	8	11400	22800	1.7	.70	2.75	5.50
X 3	1011421	3/8	10	17600	35200	2.5	.81	3.00	6.00
X 4	1011430	1/2	13	30000	60000	6.2	1.09	4.00	8.00
X 5	1011449	5/8	16	45200	90400	10.6	1.34	5.00	9.00
X 6	1011458**	3/4	19	70600	141200	18.8	1.63	5.25	10.50
X 7	1011467**	7/8	22	85400	170800	28.8	1.88	6.00	12.00

\* Minimum Ultimate Load is 4 times the Working Load Limit.  
\*\* Welded.



**A-1345N**  
Master Link  
Assembly

- Alloy Steel - Quenched and Tempered.
- Individually proof tested to values shown with certification
- Proof tested with fixture sized to prevent localized point loading per ASTM A952.
- Proof test certification shipped with each link.
- "Look for the Platinum Color - Crosby Grade 100 Alloy Products."
- Engineered Flat for use with S-1325A coupler link.

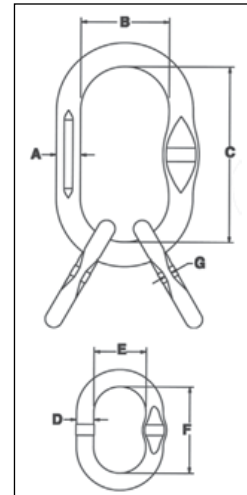

### A-1345N Master Link Assembly

A-1345N Designation Marking	A-1345N Stock No.	Grade 100 Chain Size		Working Load Limit (lb)*	Proof Load (lb)	Weight Each (lb)	Dimensions (in)						
		(in)	(mm)				A	B	C	D	E	F	G
X 2	1011501	-	6	9600	19200	2.3	.70	2.75	5.50	.50	1.57	3.35	.24
X 3	1011510	1/4-5/16	7 - 8	17100	34200	4.2	.84	3.00	6.00	.56	1.77	3.35	.30
X 4	1011529	3/8	10	26400	52800	9.4	1.09	4.00	8.00	.75	2.36	3.94	.33
X 5	1011538	1/2	13	45000	90000	19	1.34	5.00	9.00	1.00	3.00	6.30	.51
X 6	1011547	5/8	16	67800	135600	35	1.65	5.25	10.50	1.25	3.94	7.09	.65
X 7	1011556	3/4	19	105900	211800	54.2	1.88	6.00	12.00	1.50	4.25	8.00	.81
X 8	1011565	7/8	22	128100	256200	112	2.25	8.00	16.00	1.88	6.00	12.00	.88

\* Minimum Ultimate Load is 4 times the Working Load Limit.

# Crosby® Grade 100 Eye Grab Hooks



**A-1328**  
Eye Grab Hook

- Forged Alloy Steel - Quenched and Tempered.
- Individually Proof Tested to 2-1/2 times the Working Load Limit with certification
- Each hook has a Product Identification Code (PIC) for material traceability, along with the size and the name Crosby.
- Suitable for use with Grade 100 and Grade 80 chain.
- Fatigue rated at 1-1/2 times the Working Load Limit at 20,000 cycles.
- "Look for the Platinum Color – Crosby Grade 100 Alloy Products."

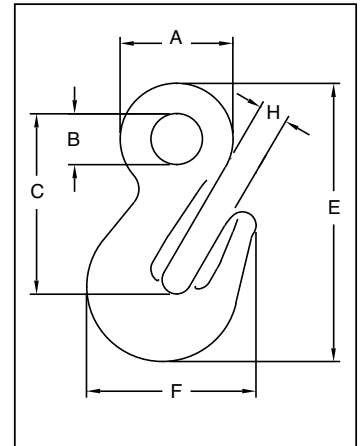

## A-1328 Eye Grab Hook

Chain Size		Working Load Limit (lb)*	A-1328 Stock No.	Weight Each (lb)	Dimensions (in)					
(in)	(mm)				A	B	C	E	F	H
1/4 - 5/16	7 - 8	5700	1026169	1.0	1.75	.75	2.79	4.29	2.57	.44
3/8	10	8800	1026187	1.6	2.06	.94	3.33	5.13	3.09	.53
1/2	13	15000	1026196	3.3	2.56	1.12	4.11	6.38	3.83	.66
5/8	16	22600	1026205	6.0	3.07	1.31	4.91	7.62	4.53	.79
3/4	18-20	35300	1026214	10.0	3.25	1.50	5.41	8.76	6.00	.94
7/8	22-23	44100	1026223	13.1	3.94	1.81	6.48	10.10	6.53	1.09
1	26	59700	1026232	18.9	4.44	2.00	7.22	11.45	7.75	1.19
1 1/4	32	90400	1026241	39.4	5.64	2.38	9.08	14.59	9.50	1.50

\* Ultimate Load is 4 times the Working Load Limit.

# Crosby® Grade 100 Eye Sling Hooks



**L-1327**  
Eye Sling Hook

- Forged Alloy Steel - Quenched and Tempered.
- Each hook has a Product Identification Code (PIC) for material traceability, along with the size and the name Crosby.
- 25% stronger than Grade 80.
- Eye Sling hooks incorporate two types of strategically placed markings forged into the product which address two (2) **QUIC-CHECK®** features: Deformation Indicators and Angle Indicators.
- Low profile hook tip
- Utilizes S-4320 integrated latch which meets the world standard for lifting.
  - Heavy duty stamped latch interlocks with the hook tip.
  - High cycle, long life spring.
- When secured with the proper cotter pin through the hole in the tip of hook, meets the intent of OSHA Rule 1926.1431(g) and 1926.1501(g) for personnel lifting.
- Individually Proof Tested to 2-1/2 times the Working Load Limit with certification
- Suitable for use with Grade 100 and Grade 80 chain.
- Fatigue rated at 1-1/2 times the Working Load Limit at 20,000 cycles.
- "Look for the Platinum Color - Crosby Grade 100 Alloy Products."

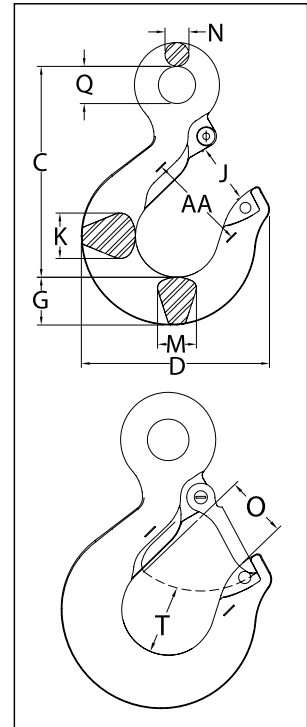

## L-1327 Eye Sling Hook

Grade 100 Alloy Chain Size		Working Load Limit (lb)*	Hook ID Code	L-1327 Stock No.	Weight Each (lb)	Dimensions (in)											Replacement Latch Stock No.
(in)	(mm)					C	D	G	J	K	M	N	O	Q	T	AA	
-	6	3200	DA	1025860	.50	3.34	2.86	.73	.90	.63	.63	.36	.89	.75	.87	1.50	1096325
1/4-5/16	7 - 8	5700	HA	1025869	1.3	4.21	3.90	1.03	1.18	.75	.75	.50	1.15	.75	1.16	2.00	1096468
3/8	10	8800	IA	1025878	2.3	4.99	4.34	1.19	1.53	1.19	1.00	.56	1.40	.94	1.23	2.50	1096515
1/2	13	15000	JA	1025887	4.5	6.36	5.67	1.44	1.78	1.37	1.17	.72	1.67	1.12	1.88	3.00	1096562
5/8	16	22600	KA	1025896	8.4	7.43	6.78	1.88	2.38	1.66	1.44	.88	2.08	1.31	2.03	4.00	1096609
3/4	18-20	35300	KA	1025915	15.0	9.07	7.45	2.25	2.38	1.88	1.63	1.11	2.08	2.44	2.47	4.00	1096609
7/8	22-23	44100	LA	1025924	20.7	10.08	8.30	2.59	2.50	2.19	1.94	1.27	2.27	2.84	2.62	4.00	1096657
1	26	59700	NA	1025933	39.5	12.82	10.30	3.00	3.30	2.69	2.38	1.56	3.02	3.50	2.83	5.00	1096704
1 1/4	32	90400	PA	1025942	105.0	18.19	14.06	4.56	4.25	3.75	3.19	2.00	3.00	4.50	3.88	7.00	1093717

\* Ultimate Load is 4 times the Working Load Limit.

# Crosby® Grade 100 Clevis Sling Hooks



**L-1339**  
Clevis Sling Hook

- Forged Alloy Steel - Quenched and Tempered.
- Individually Proof Tested to 2-1/2 times the Working Load Limit with certification
- Each hook has a Product Identification Code (PIC) for material traceability, along with the size and the name Crosby.
- Hoist hooks incorporate two types of strategically placed markings forged into the product which address two (2) **QUIC-CHECK®** features: Deformation Indicators and Angle Indicators.
- Low profile hook tip
- New integrated latch (S-4320/S-4339) meets the world standard for lifting.
  - Heavy duty stamped latch interlocks with the hook tip.
  - High cycle, long life spring.
  - When secured with the proper cotter pin through the hole in the tip of hook, meets the intent of OSHA Rule 1926.1431(g) and 1926.1501(g) for personnel lifting.
- Suitable for use with Grade 100 and Grade 80 chain.
- Fatigue rated at 1-1/2 times the Working Load Limit at 20,000 cycles.
- “Look for the Platinum Color - Crosby Grade 100 Alloy Products.”

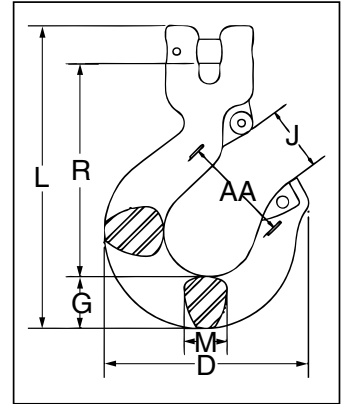

**Crosby 8/10™**



**Fatigue Rated®**



## L-1339 Clevis Sling Hook

Chain Size		Working Load Limit (lb)*	Hook ID Code	L-1339 Stock No.	Weight Each (lb)	Dimensions (in)							S-4320 Repl. Latch Stock No.	S-4339 Repl. Latch Stock No.
(in)	(mm)					D	G	J	L	M	R	AA		
-	6	3200	DA	1049103	0.64	2.86	0.73	0.93	4.21	0.63	2.95	1.50	1096325	-
1/4	7	4300	HA	1049112	1.58	3.86	1.04	1.19	5.67	0.75	3.97	2.00	1096468	-
5/16	8	5700	HA	1049121	1.57	3.86	1.04	1.19	5.67	0.75	3.95	2.00	1096468	-
3/8	10	8800	IA	1049130	2.58	4.38	1.19	1.53	6.75	1.00	4.71	2.50	1096515	-
1/2	13	15000	JA	1049149	5.28	5.60	1.44	1.78	8.38	1.17	5.89	3.00	1096562	-
5/8	16	22600	KA	1049158	9.81	6.76	1.89	2.41	10.21	1.44	6.97	4.00	1096609	-
3/4	18-20	35300	-	1049167	18.3	8.31	2.83	2.69	13.07	1.97	8.00	4.50	-	1048714
7/8**	22-23**	44100	-	1049176	24.6	9.17	3.07	3.05	13.98	1.97	8.76	5.00	-	1048732

\* Ultimate Load is 4 times the Working Load Limit.

\*\* 7/8 in (22-23 mm) size does not have cam, latch attaches to unique pin.

Chain & Accessories



# Crosby® Grade 100 Foundry Hooks



**A-1359**  
Clevis Foundry Hook

- Forged Alloy Steel - Quenched and Tempered.
- Individually Proof Tested to 2-1/2 times the Working Load Limit with certification
- Each hook has a Product Identification Code (PIC) for material traceability, along with the size and the name Crosby.
- Suitable for use with Grade 100 and Grade 80 chain.
- Fatigue rated at 1-1/2 times the Working Load Limit at 20,000 cycles.
- "Look for the Platinum Color - Crosby Grade 100 Alloy Products."
- Hook can be tip loaded at the reduced Working Load Limit, see below. Operator must ensure the load is retained properly in the hook.

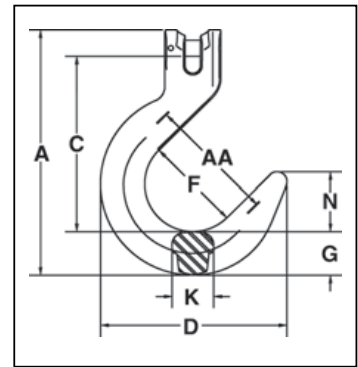

## A-1359 Clevis Foundry Hook

Chain Size		A-1359 Stock No.	Working Load Limit at Saddle of Hook (lb)*	Working Load Limit at Tip of Hook (lb)*	Weight Each (lb)	Dimensions (in)							
(in)	(mm)					A	C	D	F	G	K	N	Deformation Indicators AA
1/4	7	1049907	4300	2150	2.15	6.26	4.38	4.82	2.50	1.13	0.88	1.57	3.50
5/16	8	1049911	5700	2850	2.06	6.26	4.37	4.82	2.50	1.13	0.88	1.57	3.50
3/8	10	1049916	8800	4400	4.29	7.76	5.54	5.82	3.00	1.38	1.30	1.88	4.00
1/2	13	1049925	15000	7500	7.97	9.38	6.67	7.04	3.50	1.63	1.50	2.25	4.50
5/8	16	1049934	22600	11300	14.2	11.25	7.68	8.17	4.00	2.19	1.75	2.53	5.00
3/4	18-20	1049943	35300	17650	24.7	14.43	9.79	9.65	5.00	2.40	2.20	3.39	6.00
7/8	22-23	1049952	44100	22050	43.8	16.25	11.02	11.03	5.50	3.07	2.72	3.74	6.50

\* Ultimate Load is 4 times the Working Load Limit.

QUIC-CHECK®



**Crosby 8/10™**



**Fatigue Rated**



**A-1329**  
Eye Foundry Hook

- Forged Alloy Steel - Quenched and Tempered.
- Individually Proof Tested to 2-1/2 times the Working Load Limit with certification
- Each hook has a Product Identification Code (PIC) for material traceability, along with the size and the name Crosby.
- Suitable for use with Grade 100 and Grade 80 chain.
- Fatigue rated at 1-1/2 times the Working Load Limit at 20,000 cycles.
- "Look for the Platinum Color - Crosby Grade 100 Alloy Products."
- Hook can be tip loaded at the reduced Working Load Limit, see below. Operator must ensure the load is retained properly in the hook.

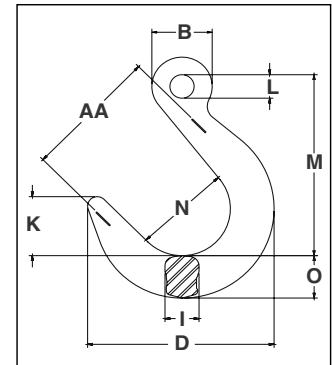

## A-1329 Eye Foundry Hook

Chain Size		A-1329 Stock No.	Working Load Limit at Saddle of Hook (lb)*	Working Load Limit at Tip of Hook* (lb)	Weight Each (lb)	Dimensions (in)								
(in)	(mm)					B	D	I	K	L	M	N	O	Deformation Indicators AA
1/4 - 5/16	7-8	1026280	5700	2850	2.00	1.56	4.82	.88	1.57	.63	4.81	2.50	1.13	3.50
3/8	10	1026289	8800	4400	3.80	2.07	5.82	1.30	1.88	.81	5.50	3.00	1.38	4.00
1/2	13	1026297	15000	7500	7.20	2.53	7.04	1.50	2.25	1.03	7.11	3.50	1.63	4.50
5/8	16	1026306	22600	11300	12.3	3.00	8.17	1.75	2.53	1.25	7.96	4.00	2.19	5.00
3/4	18-20	1026315	35300	17650	23.0	4.13	9.65	2.20	3.39	1.97	10.75	5.00	2.40	6.50
7/8	22-23	1026324	44100	22050	40.6	4.77	11.03	2.72	3.74	2.28	12.25	5.50	3.07	7.00
1	26	1026333	59700	29850	51.7	5.33	11.90	2.83	3.93	2.56	13.37	6.00	3.31	7.50
1 1/4	32	1026342	90400	45200	84.4	6.61	13.25	3.50	4.33	3.15	15.25	6.50	3.84	8.00

\* Ultimate Load is 4 times the Working Load Limit.

# Crosby® Grade 100 Clevis Grab Hooks



**A -1338**  
Cradle Grab Hook

- Forged Alloy Steel - Quenched and Tempered.
- Innovative cradle design allows for 100% efficiency of Grade 100 chain
- Individually Proof Tested to 2-1/2 times the Working Load Limit with certification
- Each hook has a Product Identification Code (PIC) for material traceability, along with the size and the name Crosby.
- Suitable for use with Grade 100 and Grade 80 chain.
- The use of A-1338 Cradle Grab Hook will allow 100 percent of the chain sling capacity. When used to hook back to chain leg to form a choker, the angle of the choke must be 120 degrees or greater. When used as a chain shortener, minimize twist of chain and ensure chain is fully engaged in hook.
- Fatigue rated at 1-1/2 times the Working Load Limit at 20,000 cycles.
- "Look for the Platinum Color - Crosby Grade 100 Alloy Products."



**L-1338**  
Cradle Grab Hook

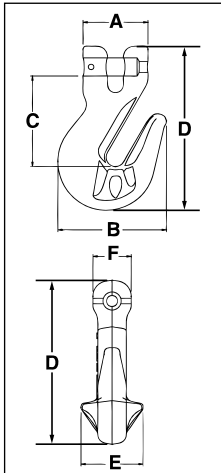

**Crosby 8/10™**



**Fatigue Rated**

## A/L-1338 Cradle Grab Hook

Chain Size (in) (mm)	Working Load Limit (lb)*	A-1338 Stock No.	L-1338 Stock No.	Weight Each (lb)	Dimensions (in)						S-4338 Replacement Latch Kit Stock No.
					A	B	C	D	E	F	
1/4 7	4300	1049417	1049480	1.00	1.72	2.54	2.20	3.88	1.50	.88	1048426
5/16 8	5700	1049426	1049489	.99	1.72	2.54	2.18	3.88	1.50	.88	1048426
3/8 10	8800	1049435	1049498	1.80	1.85	3.09	2.58	4.69	1.83	1.09	1048435
1/2 13	15000	1049444	1049507	3.92	2.39	3.83	3.28	5.88	2.25	1.42	1048444
5/8 16	22600	1049453	1049516	7.00	2.67	4.52	3.85	7.03	2.94	1.75	1048453

\* Ultimate Load is 4 times the Working Load Limit.

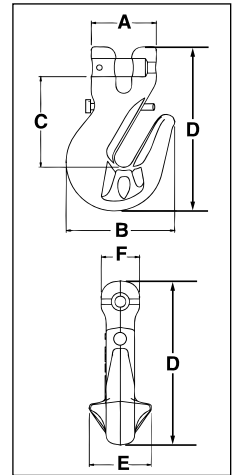

Chain & Accessories



**A -1358**  
Grab Hook

- Forged Alloy Steel - Quenched and Tempered.
- Individually Proof Tested to 2-1/2 times the Working Load Limit with certification
- Each hook has a Product Identification Code (PIC) for material traceability, along with the size and the name Crosby.
- Suitable for use with Grade 100 and Grade 80 chain.
- Fatigue rated at 1-1/2 times the Working Load Limit at 20,000 cycles.
- "Look for the Platinum Color - Crosby Grade 100 Alloy Products."



**L -1358**  
Grab Hook

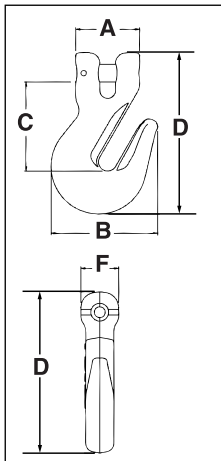

**Crosby 8/10™**



**Fatigue Rated**

## A/L-1358 Grab Hook

Chain Size (in) (mm)	Working Load Limit (lb)*	A-1358 Stock No.	L-1358 Stock No.	Weight Each (lb)	Dimensions (in)					S-4338 Replacement Latch Kit Stock No.
					A	B	C	D	F	
1/4 7	4300	1049610	1049605	1.00	1.72	2.54	2.20	3.88	.88	1048426
5/16 8	5700	1049629	1049614	.99	1.72	2.54	2.18	3.88	.88	1048426
3/8 10	8800	1049638	1049623	1.80	1.85	3.09	2.58	4.69	1.09	1048435
1/2 13	15000	1049647	1049634	3.92	2.39	3.83	3.28	5.88	1.42	1048444
5/8 16	22600	1049656	1049643	7.00	2.67	4.52	3.85	7.03	1.75	1048453

\* Ultimate Load is 4 times the Working Load Limit.

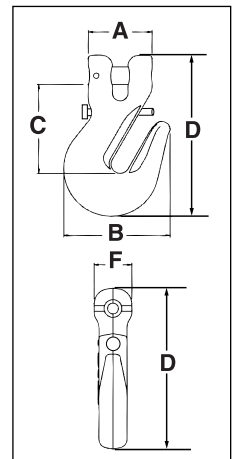

# Crosby® Grade 100 SHUR-LOC® Handle Hooks



**S-13326AH**  
SHUR-LOC® Handle Swivel Hook with Bearing

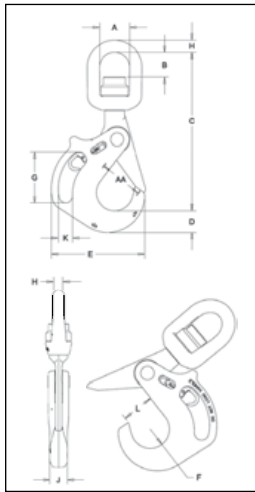

- The SHUR-LOC® Handle Hook allows the user to get a confident grip on a load with ease and comfort.
- Designed with a handle opening big enough to comfortably fit a gloved hand.
- The replaceable pull-trigger allows the user to easily open the SHUR-LOC's positive self-locking latch.
  - Ergonomically designed for easy use and precise control.
  - Secondary side trigger is recessed to avoid inadvertent release.

**All SHUR-LOC® hooks have the following features:**

- Forged Alloy Steel - Quenched and Tempered.
- Positive Lock Latch is Self-Locking when hook is loaded.
- Individually Proof Tested at 2-1/2 times the 4:1 Working Load Limit with certification
- Rated for both Wire Rope and use with Grade 80/100 Chain.
- G-414 Heavy Thimble should be used with wire rope slings.
- S-13326 Swivel Hook utilizes anti-friction bearing design which allows hook to rotate freely under load.
- Fatigue rated.
- "Look for the Platinum Color – Crosby Grade 100 Alloy Products."
- The SHUR-LOC® hook, if properly installed and locked, can be used for personnel lifting applications and meets the intent of OSHA Rule 1926.1431(g)(1)(i)(A) and 1926.1501(g)(4)(iv)(B).
- Each SHUR-LOC® handle hook has a serial number.



**S-1316AH**  
SHUR-LOC® Handle Eye Hook

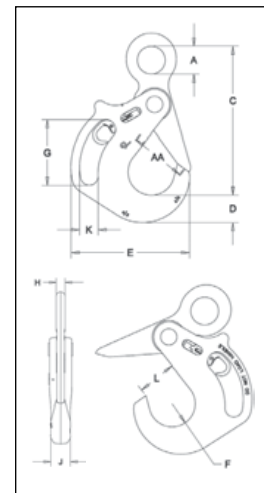

**SEE APPLICATION AND WARNING INFORMATION**  
On Pages 272 - 273  
Para Español: [www.thecrosbygroup.com](http://www.thecrosbygroup.com)



## S-13326AH SHUR-LOC® Handle Swivel Hooks with Bearings

Chain Size		Grade 100 Alloy Chain Working Load Limit (lb) 4:1*	Working Load Limit (lb) 5:1*	Frame Code	Stock No.	Weight Each (lb)	Dimensions (in)											
(in)	(mm)						A	B	C	D	E	F	G	H	J	K	L	AA**
5/8	16	22,600	18,080	JA	1005014	26	2.75	2.25	10.69	1.97	8.54	1.67	4.69	1.13	1.73	1.32	2.80	4.00
3/4	18/20	35,300	28,240	KA	1005023	37	3.12	2.04	15.49	2.60	10.03	1.99	4.72	1.25	2.05	1.26	3.31	5.00
7/8	22	42,700	34,160	LA	1005041	57	4.09	3.65	18.98	2.72	11.48	2.24	5.35	1.63	2.44	1.57	3.66	6.00
1	26	59,700	47,760	NA	1005050	84	5.00	4.02	21.55	3.11	12.77	2.52	6.46	1.63	2.76	1.57	4.09	6.50

\*Ultimate Load is 4 times the Working Load Limit. \*\* Deformation Indicators.

## S-1316AH SHUR-LOC® Handle Eye Hook

Chain Size		Grade 100 Alloy Chain Working Load Limit (lb) 4:1*	Working Load Limit (lb) 5:1*	Frame Code	Stock No.	Weight Each (lb)	Dimensions (in)											
(in)	(mm)						A	B	C	D	E	F	G	H	J	K	L	AA**
5/8	16	22,600	18,080	JA	1023579	18	2.01	10.69	1.97	8.54	1.67	4.69	0.79	1.73	2.80	4.00	2.80	4.00
3/4	18/20	35,300	28,240	KA	1023599	28	2.76	12.03	2.60	10.03	1.99	4.72	0.87	2.05	3.31	5.00	3.31	5.00
7/8	22	42,700	34,160	LA	1023607	39	3.15	13.46	2.72	11.48	2.24	5.35	3.58	2.44	3.66	6.00	3.66	6.00
1	26	59,700	47,760	NA	1023625	60	3.54	15.55	3.11	12.77	2.52	6.46	1.18	2.76	4.09	6.50	4.09	6.50

\*Ultimate Load is 4 times the Working Load Limit. \*\* Deformation Indicators.

# Crosby® Grade 100 SHUR-LOC® Hooks



**S-1316**  
Eye Hook

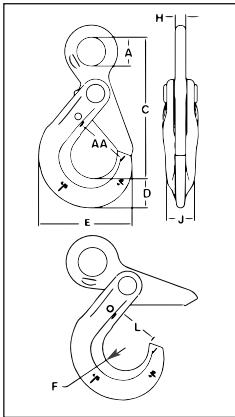

- Forged Alloy Steel - Quenched and Tempered.
- 25% stronger than Grade 80.
- Individually Proof Tested to 2-1/2 times the Working Load Limit with certification
- Recessed trigger design is flush with the hook bod , protecting the trigger from potential damage.
  - Easy to operate with enlarged thumb access.
- Positive Lock Latch is Self-Locking when hook is loaded.
- Eye style is designed with “Engineered Flat” to connect to S-1325 chain coupler.
- Suitable for use with Grade 100 and Grade 80 chain.
- The SHUR-LOC® hook, if properly installed and locked, can be used for personnel lifting applications and meets the intent of OSHA Rule 1926.1431(g)(1)(i)(A) and 1926.1501(g)(4)(iv)(B).
- Fatigue rated at 1-1/2 times the Working Load Limit at 20,000 cycles.
- “Look for the Platinum Color - Crosby Grade 100 Alloy Products.”
- Forged Alloy Steel - Quenched and Tempered.



**S-1317**  
Clevis Hook

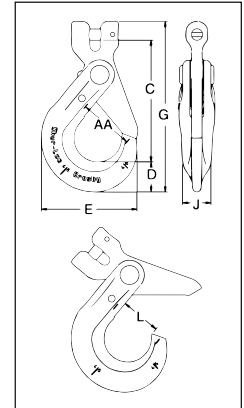

**SEE APPLICATION AND WARNING INFORMATION**  
On Pages 271-272  
Para Español: [www.thecrosbygroup.com](http://www.thecrosbygroup.com)



**SEE APPLICATION AND WARNING INFORMATION**  
On Pages 272 - 273  
Para Español: [www.thecrosbygroup.com](http://www.thecrosbygroup.com)

Chain & Accessories

## SHUR-LOC® Hook Series with Positive Locking Latch S-1316 Eye Hook

Chain Size		Working Load Limit (lb)*	S-1316 Stock No.	Weight Each (lb)	Dimensions (in)									
(in)	(mm)				A	C	D	E	F	H	J	L	AA	
-	6	3200	1022896	.85	.78	3.95	.79	2.60	.67	.31	.63	1.14	1.50	
1/4-5/16	7-8	5700	1022914	1.80	1.08	5.31	1.10	3.50	.87	.39	.81	1.48	2.00	
3/8	10	8800	1022923	3.40	1.30	6.57	1.17	4.39	1.10	.51	.94	1.83	2.50	
1/2	13	15000	1022932	6.00	1.65	8.23	1.67	5.45	1.26	.67	1.16	2.22	3.00	
5/8	16	22600	1022941	15.1	2.20	10.06	2.04	6.56	1.50	.87	1.50	2.65	3.50	
3/4	18-20	35300	1022942	19.0	2.60	10.77	2.22	7.76	2.01	.87	2.03	3.52	5.00	
7/8	22	42700	1022943	28.0	2.87	12.49	2.45	8.75	2.27	.98	2.20	3.83	6.00	
1	26	59700	1022944	49.5	3.15	14.60	3.21	9.87	2.46	1.26	2.68	4.09	6.50	

\* Minimum Ultimate Load is 4 times the Working Load Limit.

## S-1317 Clevis Hook

Chain Size		Working Load Limit (lb)*	S-1317 Stock No.	Weight Each (lb)	Dimensions (in)						
(in)	(mm)				C	D	E	G	J	L	AA
-	6	3200	1028991	.77	3.44	.79	2.60	4.75	.63	1.16	1.50
1/4	7	4300	1029000	1.80	4.48	1.10	3.51	6.25	.81	1.48	2.00
5/16	8	5700	1029009	1.80	4.47	1.10	3.51	6.25	.81	1.48	2.00
3/8	10	8800	1029018	3.66	5.53	1.17	4.39	7.54	.94	1.83	2.50
1/2	13	15000	1029027	6.80	6.81	1.67	5.49	9.52	1.16	2.22	3.00
5/8	16	22600	1029036	11.9	8.22	2.04	6.55	11.61	1.50	2.65	3.50
3/4	18-20	35300	1029071	15.0	9.42	2.22	7.76	13.21	2.03	3.52	5.00
7/8	22	42700	1029080	28.0	11.14	2.45	8.75	15.45	2.20	3.83	6.00
1	26	59700	1029089	49.5	12.56	3.21	9.87	18.44	2.68	4.09	6.50

\* Minimum Ultimate Load is 4 times the Working Load Limit.



# Crosby® Grade 100 SHUR-LOC® Hooks



**S-1326**  
SHUR-LOC® Swivel Hook

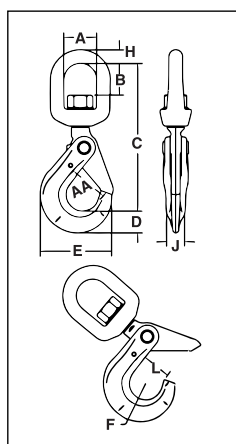

- Forged Alloy Steel - Quenched and Tempered.
- Individually Proof Tested at 2-1/2 times the Working Load Limit with certification
- Recessed trigger design is flush with the hook bod , protecting the trigger from potential damage.
  - Easy to operate with enlarged thumb access.
- Positive Lock Latch is Self-Locking when hook is loaded.
- Rated for both Wire Rope, (reference page 117 for Wire Rope), and use with Grade 80/100 Chain.
- G-414 Heavy Thimble should be used with wire rope slings.
- Trigger Repair Kit available (S-4316). Consists of spring, roll pin and trigger.
- S-13326 Swivel Hook utilizes anti-friction bearing design which allows hook to rotate freely under load.
- Fatigue rated.
- The SHUR-LOC® hook, if properly installed and locked, can be used for personnel lifting applications and meets the intent of OSHA Rule 1926.1431(g)(1)(i)(A) and 1926.1501(g)(4)(iv)(B).
- “Look for the Platinum Color – Crosby Grade 100 Alloy Products.”
- U.S. Patent 5,381,650 and foreign equivalents. Use in corrosive environment requires shank and nut inspection in accordance with ASME B30.10-1.10.4(b)(5)(c)2009.



**S-13326**  
SHUR-LOC® Swivel Hook

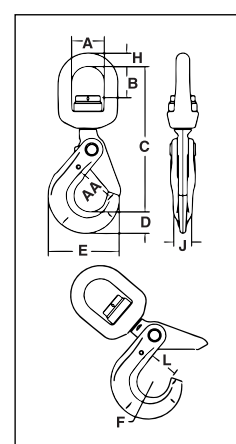

## S-1326 SHUR-LOC® Swivel Hooks • Suitable for infrequent, non-continuous rotation under load.

Chain Size		S-1326 Stock No.	Grade 100 Alloy Chain Working Load Limit (lb) 4:1*	Weight Each (lb)	Dimensions (in)										
(in)	(mm)				A	B	C	D	E	F	H	J	L	AA	
-	6	1004304	3200	1.26	1.50	1.32	6.13	.79	2.60	.67	.50	.63	1.13	1.50	
1/4-5/16	7-8	1004313	5700	2.62	1.75	1.59	7.60	1.10	3.50	.87	.63	.81	1.38	2.00	
3/8	10	1004322	8800	4.70	2.00	1.73	8.83	1.17	4.39	1.10	.75	.94	1.75	2.50	
1/2	13	1004331	15000	8.64	2.50	2.38	11.20	1.67	5.45	1.26	1.00	1.16	2.11	3.00	
5/8	16	1004340	22600	17.00	2.75	2.70	12.98	2.05	6.56	1.50	1.13	1.50	2.49	3.50	
3/4	18-20	1004349	35300	24.00	2.83	2.52	17.42	2.22	7.76	2.01	1.10	2.03	3.52	5.00	
7/8	22	1004358	42700	29.00	3.44	3.19	16.47	2.45	8.75	2.26	1.30	2.20	3.83	6.00	

\* Ultimate Load is 4 times the Working Load Limit.

## S-13326 SHUR-LOC® Swivel Hooks • Suitable for frequent rotation under load.

Chain Size		S-13326 Stock No.	Grade 100 Alloy Chain Working Load Limit (lb) 4:1*	Weight Each (lb)	Dimensions (in)										
(in)	(mm)				A	B	C	D	E	F	H	J	L	AA	
-	6	1004404	3200	1.50	1.50	1.14	6.17	.79	2.60	.67	.50	.63	1.13	1.50	
1/4-5/16	7-8	1004413	5700	3.10	1.75	1.52	7.54	1.10	3.50	.87	.63	.81	1.44	2.00	
3/8	10	1004422	8800	5.26	2.00	1.61	8.88	1.16	4.35	1.10	.75	.94	1.83	2.50	
1/2	13	1004431	15000	11.22	2.50	2.03	11.11	1.66	5.45	1.26	1.00	1.16	2.19	3.00	
5/8	16	1004440	22600	17.32	2.75	2.25	12.61	2.05	6.56	1.50	1.13	1.50	2.61	3.50	

\* Ultimate Load is 4 times the Working Load Limit.

# Crosby® Grade 100 Chain Fittings



**S-1325A**  
Chain Coupler

- Designed to connect Grade 100 chain fittings produced with “Engineered Flat” to Grade 100 chain.
- Forged Alloy Steel - Quenched and Tempered.
- Suitable for use with Grade 100 and Grade 80 chain.
- Individually Proof Tested to 2-1/2 times the Working Load Limit with certification
- Locking system that provides for simple assembly and disassembly – no special tools required.
- Fatigue rated at 1-1/2 times the Working Load Limit at 20,000 cycles.
- “Look for the Platinum Color – Crosby Grade 100 Alloy Products.”

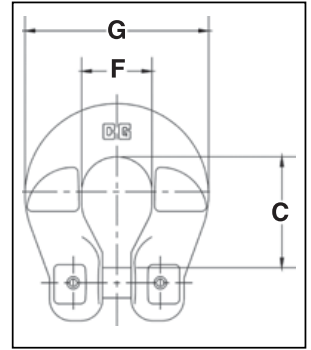

**Crosby 8/10™**

**“QT”**  
QUENCHED & TEMPERED

**Fatigue Rated**

## S-1325A Grade 100 Chain Coupler

Chain Size		S-1325A Stock No.	Working Load Limit (lb)*	Weight Each (lb)	Dimensions (in)		
(in)	(mm)				C	F	G
-	6	1098496	3200	.25	1.03	.74	1.74
1/4	7	1098500	4300	.50	1.41	.88	2.32
5/16	8	1098504	5700	.50	1.40	.88	2.32
3/8	10	1098508	8800	.80	1.84	1.18	2.72
1/2	13	1098512	15000	1.70	2.12	1.50	3.62
5/8	16	1098516	22600	1.90	2.84	1.96	4.40

\* Minimum Ultimate Load is 4 times the Working Load Limit.

Chain & Accessories



**S-1311N**  
Chain Shortener Link

- Alloy Steel - Quenched and Tempered.
- Individually Proof Tested to 2-1/2 times the Working Load Limit with certification
- Suitable for use with Grade 100 and Grade 80 chain.
- Spring loaded chain locking system keeps chain in place under slack conditions.
- The use of S-1311N Chain Shortener will allow 100 percent of the chain sling capacity.
- Fatigue rated at 1-1/2 times the Working Load Limit at 20,000 cycles.
- “Look for the Platinum Color - Crosby Grade 100 Alloy Products.”

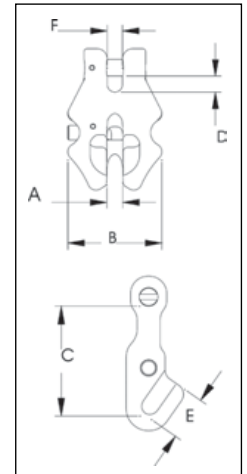

**Crosby 8/10™**

**“QT”**  
QUENCHED & TEMPERED

**Fatigue Rated**

## S-1311N Grade 100 Chain Shortener Link

Chain Size		S-1311N Stock No.	Working Load Limit (lb)*	Weight Each (lb)	Dimensions (in)					
(in)	(mm)				A	B	C	D	E	F
-	6	1017860	3200	.49	.30	1.76	1.83	.29	.76	.29
1/4	7	1017869	4300	.84	.34	2.04	2.17	.34	.88	.33
5/16	8	1017878	5700	1.22	.40	2.36	2.53	.39	1.01	.38
3/8	10	1017897	8800	2.03	.48	2.84	3.07	.48	1.23	.46
1/2	13	1017906	15000	4.31	.62	3.56	3.77	.61	1.57	.59
5/8	16	1017915	22600	7.20	.73	4.24	4.64	.73	1.91	.70

\* Minimum Ultimate Load is 4 times the Working Load Limit.



**A-1355**  
Chain Choker Hook

- Forged Alloy Steel - Quenched and Tempered.
- Individually Proof Tested with certification
- Rated for Grade 100 chain in choker applications.
- Each hook has a Product Identification Code (PIC) for material traceability, along with the size and the name Crosby.
- 25% stronger than Grade 80.
- Fatigue rated at 1-1/2 times the Working Load Limit at 20,000 cycles.
- "Look for the Platinum Color - Crosby Grade 100 Alloy Products."
- For use with S-1325 Chain Coupler Link.

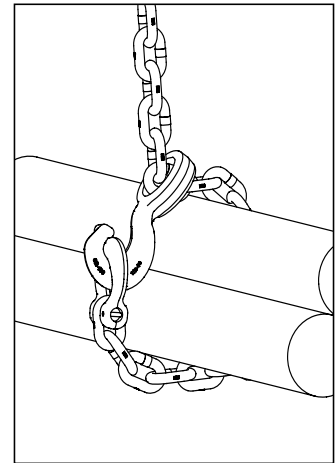

**Crosby 8/10™**

**"QT"**

**Fatigue Rated**

## A-1355 Chain Choker Hook

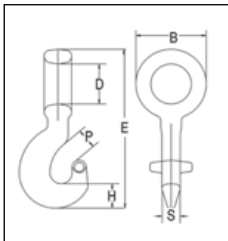

Grade 100 Alloy Chain Size		Working Load Limit (lb)*	A-1355 Stock No.	Weight Each (lb)	Dimensions (in)					
(in)	(mm)				B	D	E	H	P	S
1/4-5/16	7-8	5700	1015204	.77	2.05	1.18	4.83	.79	.69	.65
3/8	10	8800	1015213	1.65	2.66	1.57	6.07	.93	.93	.69
1/2	13	15000	1015222	3.14	3.35	2.03	7.61	1.18	1.26	.94
5/8	16	22600	1015231	6.97	4.21	2.52	9.68	1.54	1.12	1.18

\* Ultimate Load is 4 times the Working Load Limit.

## SLING IDENTIFICATION TAG KITS



**Stamped ID Tag**



**RFID Equipped Tags**



**Forged ID Tags**



**Stamped RFID Tag**



**Wire Rope**



**RFID QUIC Tag**

### Stamped ID Tags

- Heavy Duty, Prestamped, Zinc plated metal tag.
- 4-1/8" x 1-7/16" tag dimensions.
- 2-1/2" diameter metal attaching ring.
- Tag prestamped for simple inclusion of sling type, Working Load Limit, reach, serial number, chain size and grade.

ID Tag Stock No.	Carton Qty.	Weight Per Carton (lb)
115244	50	10.55

### ID Tags

- Heavy Duty tags.
- 1-5/16" diameter ring opening (will fit 1/4" - 5/8" A-1337).
- Chain tags meet requirements of ASME B30.9 for Sling Identification
- Raised edge and recessed pads to protect lettering.
- Raised lettering for quick reference.



Stock No.	Style	Material Type	RFID Equipped	Tag Size (in)	Weight Each (lb)
115369	Chain	Cast Stainless Steel	Yes	6-5/16 x 1-5/8	.46
115350	Wire Rope	Cast Stainless Steel	Yes	1-11/16 x 1-5/16	.07
115217	Chain	Forged Steel	No	5-3/4 x 1-7/8	.40
115353	Chain	Stamped Zinc Plated Steel	Yes	5-3/4 x 1-5/8	.29
115355	Wire Rope	Stamped Zinc Plated Steel	Yes	1-11/16 x 1-5/16	.04
1224692	Zip Tie	High Crystalline Polyamide	Yes	7.625	.05



Crosby Red-Pin® Shackles

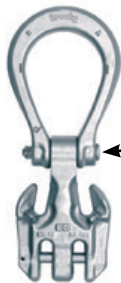

Crosby Eliminator®



McKissick® Blocks



CrosbyIP® Lifting Clamps



Crosby Clamp-Co® Lifting Clamps



Crosby® Hoist Rings

# RFID Field Installation Instruction Manual

Many standard Crosby products come from the factory, equipped with RFID chips that you can program and utilize in your inspection efforts. However, what if you want to retrofit an RFID chip to a Crosby product in the field? No problem! We now have a NEW installation instruction manual available to attach RFID chips to selected Crosby products. The installation instructions will show you the step-by-step process to add an RFID chip to the products to the left.

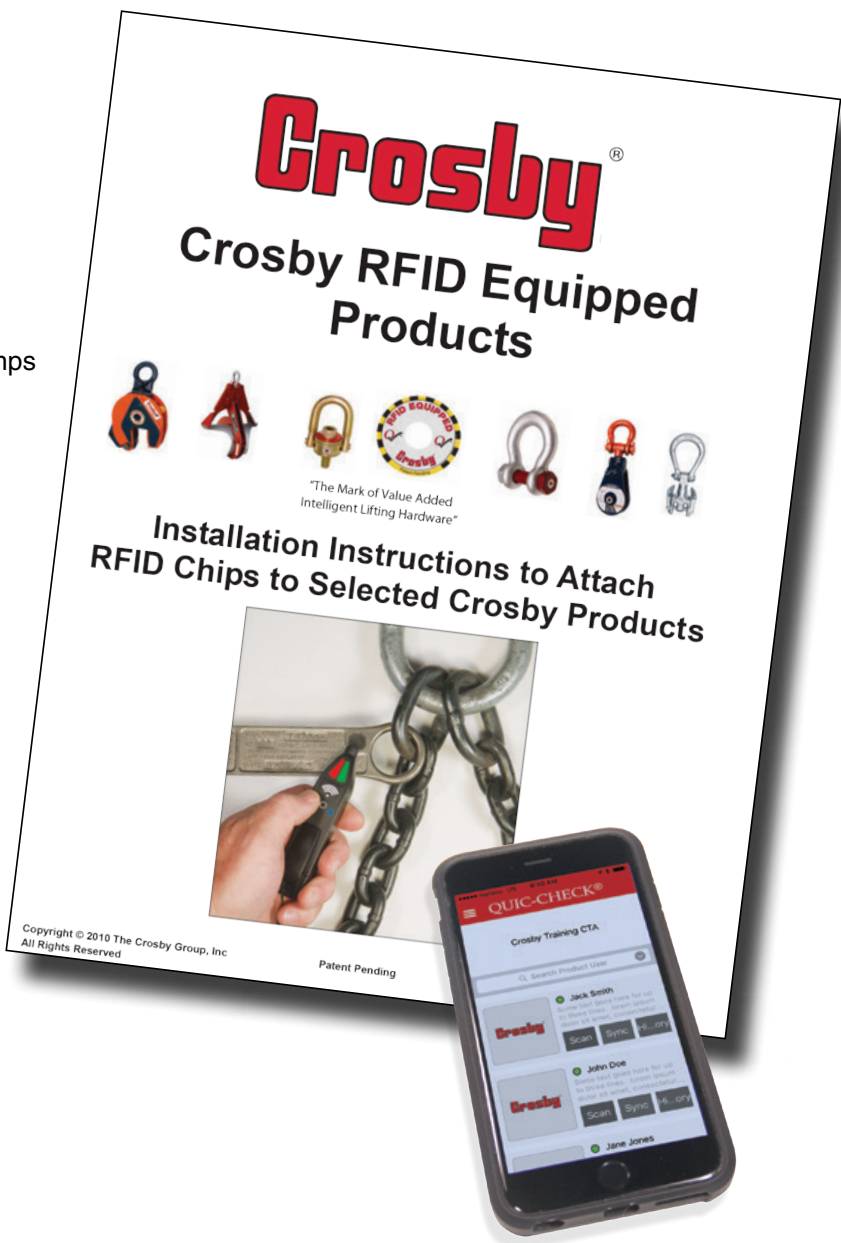

Copyright © 2010 The Crosby Group, Inc  
All Rights Reserved

Patent Pending





# Grade 80 Chain Sling Components

## WORKING LOAD LIMIT – 4 TO 1 DESIGN FACTOR

Spectrum 8 <sup>®</sup> Alloy Chain Size		90°	60°	45°	30°	60°	45°	30°
(in)	(mm)	Single Leg (lbs)	Double Leg (lbs)		Triple and Quad Leg (lbs)			
—	6	2500	4330	3540	2500	6500	5300	3750
1/4 (9/32)	7	3500	6100	4900	3500	9100	7400	5200
5/16	8	4500	7800	6400	4500	11700	9500	6800
3/8	10	7100	12300	10000	7100	18400	15100	10600
1/2	13	12000	20800	17000	12000	31200	25500	18000
5/8	16	18100	31300	25600	18100	47000	38400	27100
3/4	20	28300	49000	40000	28300	73500	60000	42400
7/8	22	34200	59200	48400	34200	88900	72500	51300
1	26	47700	82600	67400	47700	123900	101200	71500
1-1/4	32	72300	125200	102200	72300	187800	153400	108400

For choker applications, the Working Load Limit must be reduced by 20%. The Crosby A-1338 cradle grab hook and S1311N chain shortener link does not require any reduction of the Working Load Limit. The design factor of 4 to 1 on Spectrum<sup>®</sup> 8 Alloy Chain agrees with the design factor used by the International Standards Organization (I.S.O.) and ASME B30.9 and is the preferred set of Working Load Limit values to be used.

### SINGLE LEG SLING

Spectrum 8 Chain Size (in) (mm)														
	Grade 8 Chain Stock No.	Master Link A-342 Stock No.	Master Link Assembly A-345 Stock No.	Master Link with Flat A-344 Stock No.	Master Link Assembly A-347 Stock No.	LOK-A-LOY A-1337 Stock No.	Chain Coupler S-1325 Stock No.	Clevis Sling Hook L-1339 Stock No.	SHUR-LOC Clevis Hook S-1317 Stock No.	Latching Clevis Chain Hook S-314A Stock No.	Clevis Grab Hook A-338 Stock No.	Cradle Grab Hook A-1338 Stock No.	Eye Sling Hook L-1327 Stock No.	Eye Foundry Hook A-1329 Stock No.
1/4 7	273527	1014266	—	1256862	—	1015104	1098500	1049112	1029000	1225021	1027659	1049417	1025869	1026280
5/16 8	273536	1014266 1014280 1014285	—	1256932	—	1015113	1098504	1049121	1029009	1225021	—	1049426	1025869	1026280
3/8 10	273545	1014285 1014319	—	1257002	—	1015122	1098508	1049130	1029018	1225091	1027677	1049435	1025878	1026289
1/2 13	273554	1014319 1014331	—	1257072	—	1015136	1098512	1049149	1029027	1225161	1027686	1049444	1025887	1026297
5/8 16	273563	1014331 1014348	—	1257212	—	1015145	1098516	1049158	1029036	1225162	1027695	1049453	1025896	1026306
3/4 20	273572	1014348 1014365	—	1257382	—	1015154	—	1049167	—	—	1027702	—	1025915	1026315
7/8 22	273581	1014365 1014388	—	1257422	—	1015163	—	1049176	—	—	1027711	—	1025924	1026324
1 26	273590	1014388 1014404	—	1257492	—	1015172	—	—	—	—	—	—	1025933	—
1-1/4 32	273599	1014404 1014422	—	1257632	—	1015181	—	—	—	—	—	—	1025942	—

+ Available in eye style.

### DOUBLE LEG SLING

Spectrum 8 Chain Size (in) (mm)														
	Grade 8 Chain Stock No.	Master Link A-342 Stock No.	Master Link Assembly A-345 Stock No.	Master Link with Flat A-344 Stock No.	Master Link Assembly A-347 Stock No.	LOK-A-LOY A-1337 Stock No.	Chain Coupler S-1325 Stock No.	Clevis Sling Hook L-1339 Stock No.	SHUR-LOC Clevis Hook S-1317 Stock No.	Latching Clevis Chain Hook S-314A Stock No.	Clevis Grab Hook A-338 Stock No.	Cradle Grab Hook A-1338 Stock No.	Eye Sling Hook L-1327 Stock No.	Eye Foundry Hook A-1329 Stock No.
1/4 7	273527	1014266	—	1256932	—	1015104	1098500	1049112	1029000	1225021	1027659	1049417	1025869	1026280
5/16 8	273536	1014280	—	1257002	—	1015113	1098504	1049121	1029009	1225021	—	1049426	1025869	1026280
3/8 10	273545	1014319	—	1257072	—	1015122	1098508	1049130	1029018	1225091	1027677	1049435	1025878	1026289
1/2 13	273554	1014331	—	1257282	—	1015136	1098512	1049149	1029027	1225161	1027686	1049444	1025887	1026297
5/8 16	273563	1014348	—	1257422	—	1015145	1098516	1049158	1029036	1225162	1027695	1049453	1025896	1026306
3/4 20	273572	1014365	—	1257492	—	1015154	—	1049167	—	—	1027702	—	1025915	1026315
7/8 22	273581	1014388	—	1257562	—	1015163	—	1049176	—	—	1027711	—	1025924	1026324
1 26	273590	1014404	—	1257632	—	1015172	—	—	—	—	—	—	1025933	—
1-1/4 32	273599	1014422	—	—	—	1015181	—	—	—	—	—	—	1025942	—

+ Available in eye style.

### TRIPLE AND QUADRUPLE LEG SLING

Spectrum 8 Chain Size (in) (mm)														
	Grade 8 Chain Stock No.	Master Link A-342 Stock No.	Master Link Assembly A-345 Stock No.	Master Link with Flat A-344 Stock No.	Master Link Assembly A-347 Stock No.	LOK-A-LOY A-1337 Stock No.	Chain Coupler S-1325 Stock No.	Clevis Sling Hook L-1339 Stock No.	SHUR-LOC Clevis Hook S-1317 Stock No.	Latching Clevis Chain Hook S-314A Stock No.	Clevis Grab Hook A-338 Stock No.	Cradle Grab Hook A-1338 Stock No.	Eye Sling Hook L-1327 Stock No.	Eye Foundry Hook A-1329 Stock No.
1/4 7	273527	—	1014739	—	1257832	1015104	1098500	1049112	1029000	1225021	1027659	1049417	1025869	1026280
5/16 8	273536	—	1014742	—	1257972	1015113	1098504	1049121	1029009	1225021	—	1049426	1025869	1026280
3/8 10	273545	—	1014766	—	1258142	1015122	1098508	1049130	1029018	1225091	1027677	1049435	1025878	1026289
1/2 13	273554	—	1014779	—	1258182	1015136	1098512	1049149	1029027	1225161	1027686	1049444	1025887	1026297
5/8 16	273563	—	1014807	—	1258332	1015145	1098516	1049158	1029036	1225162	1027695	1049453	1025896	1026306
3/4 20	273572	—	1014810	—	1258402	1015154	—	1049167	—	—	1027702	—	1025915	1026315
7/8 22	273581	—	1014845	—	1258462	1015163	—	1049176	—	—	1027711	—	1025924	1026324
1 26	273590	—	1014845	—	—	1015172	—	—	—	—	—	—	1025933	—
1-1/4 32	273599	—	1014986	—	—	1015181	—	—	—	—	—	—	1025942	—

+ Available in eye style.

# Crosby® Grade 80 Chain Sling Configurations

## HOW TO MAKE YOUR CROSBY® GRADE 80 ALLOY CHAIN SLING

Follow these simple steps in making a sling assembly:

1. Determine the maximum load to be lifted by the sling assembly.
2. Choose the type of sling assembly suited for the shape of the load and the size of the sling assembly for the load to be lifted. The decision must take into account the angle of the sling legs in multileg slings.
3. Determine the overall reach from bearing point of master link to bearing point on hook (see Fig. 1).
4. Select components, assemble chain and components.
5. Affix sling identification tag to sling. The tag is available from your Authorized Crosby Distributor.

Each sling shall be marked to show: name or trademark of manufacturer, grade, nominal chain size, number of legs, rated load for the type(s) of hitch(es) used and angle upon which it is based.

If measurement comes in the link, cut the following link. For two leg type slings, count the links and use an even number for clevis hooks



Fig. 1

and an odd number for eye hooks. This will position hooks in the same plane. In multileg slings always use the same number of links in each leg.

When using chain slings in choker applications, the Working Load Limit must be reduced by 20%. Crosby recommends a minimum angle of choke of 120 degrees. Consult Crosby when planning to use an angle of choke of less than 120 degrees. If Crosby A-1338 cradle grab hooks are used at a minimum angle of choke of 120 degrees, the full sling rated WLL can be utilized.



In shortening applications, a 20% reduction of the Working Load Limit is required except when using the Crosby A-1338 Cradle Grab Hooks, S-1311 Chain Shortener Link, the A-1355 Chain Choker Hook in conjunction with the S-1325 Chain Coupler Link, or the Crosby **ELIMINATOR®** shortener link. They can be used without any reduction to the Working Load Limit.



The Slings shown here are standard assemblies that can be made from "Proof Tested" Crosby Components and Alloy Chain supplied by your authorized Crosby distributor. Assemblies must include chain sling identification tag (not shown, see page 238).



TYPE CO    TYPE SOS    TYPE SOG    TYPE SOF    TYPE SSS    TYPE SGS    TYPE ASOS    TYPE ASOF    TYPE ASOG    TYPE SOCH

Type	Description	Type	Description
CO	Single Chain Sling with Master Link each end	SGS	Single Chain Sling with Grab Hook and Sling Hook
SOS	Single Chain Sling with Master Link and Sling Hook	ASOS	Adjustable Single Chain with Master Link and Sling Hook
SOG	Single Chain Sling with Master Link and Grab Hook	ASOF	Adjustable Single Chain Sling with Master Link and Foundry Hook
SOF	Single Chain Sling with Master Link and Foundry Hook	ASOG	Adjustable Single Chain Sling with Master Link and Grab Hook
SSS	Single Chain Sling with Sling Hook each end	SOCH	Single with 1355 Choker



TYPE DOS    TYPE DOG    TYPE DOF    TYPE ADOS    TYPE ADOG    TYPE DOCH

Type	Description	Type	Description
DOS	Double Chain Sling with Master Link and Sling Hook	ADOS	Adjustable Double Chain Sling with Master Link and Sling Hook
DOG	Double Chain Sling with Master Link and Grab Hook	ADOG	Adjustable Double Chain Sling with Master Link and Grab Hook
DOF	Double Chain Sling with Master Link and Foundry Hook	DOCH	Double with 1355 Choker



TYPE TOS    TYPE TOG    TYPE TOF    TYPE TOCH    TYPE QOS    TYPE QOG    TYPE QOF

Type	Description	Type	Description
TOS	Triple Chain Sling with Master Link and Sling Hook	QOS	Quadruple Chain Sling with Master Link and Sling Hook
TOG	Triple Chain Sling with Master Link and Grab Hook	QOG	Quadruple Chain Sling with Master Link and Grab Hook
TOF	Triple Chain Sling with Master Link and Foundry Hook	QOF	Quadruple Chain Sling with Master Link and Foundry Hook
TOCH	Triple Chain Sling with 1355 Choker		

Spectrum 8® Alloy Chain

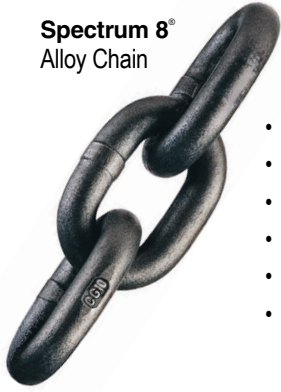

- Alloy Steel.
- Heat Treated.
- Finish – Black rust preventative coating.
- Permanently embossed with CG (Crosby Group) and 8 (Grade).
- Proof Tested at 2 times the Working Load Limit with certification
- Standard container – fiber drum

Grade 80 Alloy Chain (Recommended for overhead lifting applications)

Chain Size (in)	Spec. 8 Drum Stock No.	Feet Per Drum	Material Size (in)	Working Load Limit (lb)*	Maximum Inside Length (in)	Maximum Inside Width (in)	Maximum Length 100 Links (in)	Weight Per 100 Feet (lb)
9/32 (1/4)	273527	500	.276	3500	.87	.42	90	72
5/16	273536	500	.343	4500	1.01	.49	100	114
3/8	273545	500	.394	7100	1.23	.58	125	148
1/2	273554	300	.512	12000	1.57	.77	164	243
5/8	273563	200	.630	18100	1.93	.90	202	351
3/4	273572	100	.787	28300	2.42	1.14	252	584
7/8	273581	100	.866	34200	2.66	1.26	277	705
1	273590	75	1.024	47700	3.28	1.54	328	1041
1-1/4	273599	66	1.260	72300	4.03	1.89	403	1478

\* Proof loaded at 2 times Working Load Limit. Ultimate Load is 4 times the Working Load Limit.

Crosby provides two methods of attaching Spectrum 8® chain to Crosby fittings.

**CONNECTING AND COUPLER CHAIN LINKS**



**A-1337**  
**LOK-A-LOY®**  
Connecting Link  
Refer to page 227



**S-1325**  
**Grade 100**  
Coupler Link  
Refer to page 237

# Alloy Master Links



**A-342**  
Alloy Master Link

**Ratings below are for use with chain slings fabricated in accordance with ASME B30.9. For other applications, see pages 160.**

- Alloy Steel – Quenched and Tempered.
- Proof Tested with special fixtures sized to prevent localized point loading. See pages 160 and 276 for proof test values and fixtures
- Crosby 7/8" to 2" 342 master links are type approved to DNV GL-ST-E271-2.7-1 Offshore Containers. These Crosby master links are 100% proof tested, MPI and impact tested. The tests are conducted by Crosby and 3.1 test certification is available upon request. Refer to page 164 for Crosby COLD TUFF® master links that meet the additional requirements of DNV rules for certification of lifting appliances - Loose Gear.
- Meets or exceeds all requirements of ASME B30.26 including identification, ductility, design factor, proof load and temperature requirements. Importantly, these links meet other critical performance requirements including fatigue life, impact properties and material traceability, not addressed by ASME B30.26.
- Forgings have a Product Identification Code (PIC) for material traceability, along with the size, the name Crosby and USA in raised lettering.
- Selected sizes designated with "W" in the size column have enlarged inside dimensions to allow additional room for sling hardware and crane hook.
- Incorporates patented **QUIC-CHECK®** deformation indicators.

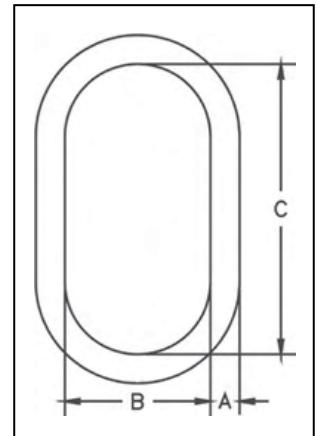

Chain & Accessories

## A-342 Alloy Master Links

Size		A-342 Stock No.	Weight Each (lb)	Chain Size		Single Leg		Double Leg		Dimensions (in)			
(in)	(mm)			(in)	(mm)	WLL Based on Grade 80 Chain (lb)*	WLL Based on Grade 100 Chain (lb)*	WLL Based on Grade 80 Chain 60° Sling Angle (lb)*	WLL Based on Grade 100 Chain 60° Sling Angle (lb)*	A	B	C	Deformation Indicator
1/2W	13W	1014266	1.3	1/4	7	3500	4300	6100	7400	.62	2.80	5.00	3.50
				5/16	8	4500	5700	-	-				
5/8	16	1014280	1.5	5/16	8	4500	5700	7800	-	.62	3.00	6.00	3.50
				5/16	8	4500	5700	-	9900				
3/4W	19W	1014285	2.0	3/8	10	7100	8800	12300	-	.73	3.20	6.00	4.00
				3/8	10	7100	8800	12300	15200				
7/8W	22W	3522213	3.3	1/2	13	12000	15000	-	-	.88	3.75	6.38	4.50
				1/2	13	12000	15000	20800	26000				
1W	26W	3522214	6.1	5/8	16	18100	22600	-	-	1.10	4.30	7.50	5.50
				5/8	16	18100	22600	31300	39100				
1-1/4W	32W	3522215	12.0	3/4	20	28300	35300	-	-	1.33	5.50	9.50	7.00
				3/4	20	28300	35300	49000	61100				
1-1/2W	38W	3522216	18.6	7/8	22	34200	42700	-	-	1.61	5.90	10.50	7.50
				7/8	22	-	-	59200	74000				
1-3/4	44	3522217	25.2	1	26	47700	59700	-	-	1.75	6.00	12.00	7.50
				1	26	-	-	82600	103400				
2	51	3522218	37.0	1-1/4	32	72300	90400	-	-	2.00	7.00	14.00	9.00
				1-1/4	32	-	-	125200	-				
2-1/4	57	1014422	54.1	1-1/4	32	-	-	125200	-	2.25	8.00	16.00	10.00
2-1/2	63	1014468	68.5	1-1/4	32	72300	90400	125200	156600	2.5	8.38	16.00	11.00

\* Chain slings require that the Minimum Ultimate Load be 4 times the Working Load Limit. Refer to page 160 to determine products actual Ultimate Load. Proof Test Load equals or exceeds the requirement of ASTM A952(8.1) and ASME B30.9-1.4 for the chain size and number of legs. See chart on page 240 for other sling angles.



## Alloy Master Link Assembly with Engineered Flat



**A-345**  
Master Link Assembly  
with Engineered Flat

Ratings below are for use with chain slings fabricated in accordance with ASME B30.9. For other applications, see pages 161.

- Alloy Steel – Quenched and Tempered.
- Individually Proof Tested with certification. (See pages 161 for Proo Test values.)
- Proof Tested with 60% inside width special fixtures sized to prevent localized point loading per ASTM A-952. Reference page 276.
- Meets or exceeds all requirements of ASME B30.26 including identification, ductility, design factor, proof load and temperature requirements. Importantly, these links meet other critical performance requirements including fatigue life, impact properties and material traceability, not addressed by ASME B30.26.
- Forgings have a Product Identification Code (PIC) for material traceability, along with the size, the name Crosby and USA in raised lettering.
- Selected sizes designated with “W” in the size column have enlarged inside dimensions to allow additional room for sling hardware and crane hook.
- Incorporates patented **QUIC-CHECK**® deformation indicators.

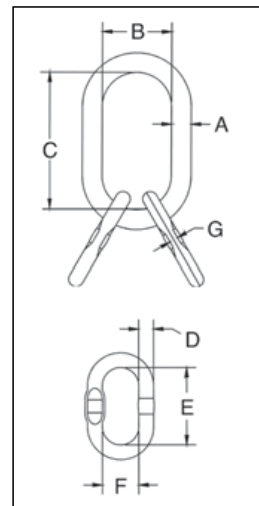

### A-345 Master Link Assembly with Engineered Flat (for use with S-1325A coupler link)

Size		A-345 Stock No.	Weight Each (lb)	Chain Size		Three and Four Leg Sling		Dimensions (in)							Engineered Flat for S-1325 (in) — (mm)	
(in)	(mm)			(in)	(mm)	WLL Based on Grade 80 Chain 60° Sling Angle (lb)*	WLL Based on Grade 100 Chain 60° Sling Angle (lb)*	A	B	C	D	E	F	G		Deformation Indicator
3/4W	19W	1014739	3.5	1/4	7	9100	11200	.73	3.20	6.00	.56	3.35	1.77	.30	4.00	1/4"-5/16", 7-8mm
7/8W	22W	1014742	4.8	5/16	8	11700	14800	.88	3.75	6.38	.56	3.35	1.77	.30	4.50	-
1W	26W	1014766	9.3	3/8	10	18400	22900	1.10	4.30	7.50	.75	3.94	2.36	.33	5.50	3/8", 10mm
1-1/4W	32W	1014779	15.8	1/2	13	31200	39000	1.33	5.50	9.50	1.00	6.30	3.54	.51	7.00	1/2", 13mm
1-1/2W	38W	1014807	34.1	5/8	16	47000	58700	1.61	5.90	10.50	1.25	7.09	3.94	.65	7.50	5/8", 16mm
1-3/4	44	1014810	46.7	3/4	20	73500	91700	1.75	6.00	12.00	1.50	6.00	4.00	-	7.50	No Flat
2-1/4	57	1014845	97	7/8	22	88900	110900	2.25	8.00	16.00	1.88	8.00	5.50	-	10.00	No Flat
				1	26	123900	155100	2.25	8.00	16.00	1.88	8.00	5.50	-	10.00	No Flat
3-1/4	83	1014986	255	1-1/4	32	187800	234900	3.25	10.00	20.00	2.50	11.25	8.00	-	13.50	No Flat

\* Chain slings require that the Minimum Ultimate Load be 4 times the Working Load Limit. Refer to page 161 to determine products actual Ultimate Load. Proof Test Load equals or exceeds the requirement of ASTM A952(8.1) and ASME B30.9-1.4 for the chain size and number of legs. See chart on page 240 for other sling angles.

# Welded Master Links Assembly with Engineered Flat



**A-344**

## Welded Master Link

Ultimate Load is 5 times the Working Load Limit. Applications with wire rope and synthetic sling generally require a design factor of 5. Based on single leg sling (in-line load), or resultant load on multiple legs with an included angle less than or equal to 120 degrees. \*\* Proof Test Load equals or exceeds the requirement of ASTM A952(8.1) and ASME B30.9. For use with chain slings, refer to page 245 for sling ratings and page 240 for proper master link selection.

- Alloy Steel - Quenched and Tempered.
- Individually Proof Tested to values shown, with certification
- Proof Tested with 70% inside width special fixtures sized to prevent localized point loading per EN 1677-4, reference page 276.
- Each link has a Product Identification Code (PIC) for material traceability, along with the size and the name Crosby® or “CG”.
- Large inside width and length to allow additional room for sling hardware and crane hook.
- Engineered Flat for use with S-1325A coupler link.
- Meets or exceeds all requirements of ASME B30.26 including identification, ductility, design factor, proof load and temperature requirements. Importantly, these links meet other critical performance requirements including fatigue life, impact properties and material traceability, not addressed by ASME B30.26.
- Master links are type approved to DNV Certification Notes 2.7-1-Offshore Containers. These Crosby master links are 100% proof tested and impact tested. The tests are conducted by Crosby and 3.1 test certification is available upon request.
- 7/16” through 1-7/32” have Engineered Flat.

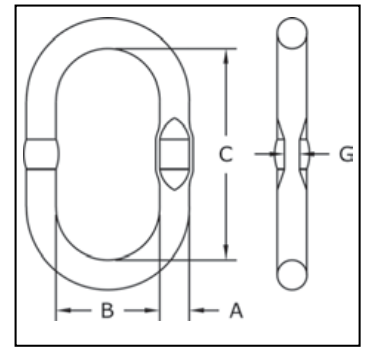

7/16" through 1-7/32" have Engineered Flat



Chain & Accessories

## A-344 Welded Master Link with Engineered Flat

Size		A-344 Stock No.	Weight Each (lb)	Single Leg			Double Leg			Dimensions (in)				Engineered Flat Size for S-1325A (in)
(in)	(mm)			Chain Size		WLL Based on Grade 8 Chain (lb)*	Chain Size		WLL Based on Grade 8 Chain 60° Sling Angle (lb)*	A	B	C	G	
				(in)	(mm)		(in)	(mm)						
7/16	12	1256862	0.66	1/4	7	3500	-	-	-	.47	2.36	4.72	.24	1/4
1/2	13	1256932	0.79	5/16	8	4500	1/4	7	6100	.51	2.36	4.72	.26	1/4
11/16	17	1257002	1.85	3/8	10	7100	5/16	8	7800	.67	3.54	6.30	.33	3/8
3/4	19	1257072	2.36	1/2	13	12000	3/8	10	12300	.75	3.54	6.30	.33	3/8
7/8	22	1257212	3.55	5/8	16	18100	-	-	-	.87	3.94	7.10	.41	1/2
1	25	1257282	5.22	-	-	-	1/2	13	20800	.98	4.53	8.10	.53	1/2
1-1/8	28	1257382	8.33	3/4	20	28300	-	-	-	1.10	5.71	10.83	.53	1/2
1-7/32	31	1257422	10.3	7/8	22	34200	5/8	16	31300	1.22	5.71	10.83	.61	5/8
1-7/16	36	1257492	15.1	1	26	47700	3/4	20	49000	1.42	6.10	11.20	-	---
1-3/4	45	1257562	28.1	-	-	-	7/8	22	59200	1.77	7.10	13.40	-	---
2	51	1257632	38.1	1-1/4	32	72300	1	26	82600	2.00	8.50	15.30	-	---

\* Chain slings require that the Minimum Ultimate Load be 4 times the Working Load Limit. Refer to page 162 to determine products actual Ultimate Load. See chart on page 240 for other sling angles.

\*\*There are no manufactured flats on links over 31mm (1 1/4)

# Welded Master Links Assembly with Engineered Flat

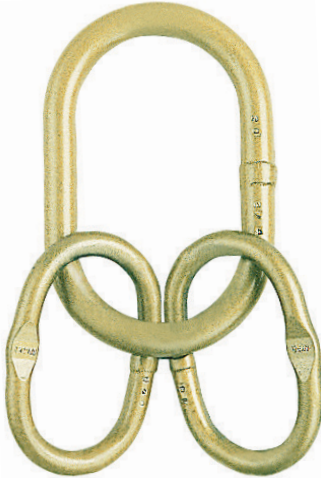

**A-347**

**Welded Master Link**

Ultimate Load is 5 times the Working Load Limit. Applications with wire rope and synthetic sling generally require a design factor of 5. Based on single leg sling (in-line load), or resultant load on multiple legs with an included angle less than or equal to 120 degrees. \*\* Proof Test Load equals or exceeds the requirement of ASTM A952(8.1) and ASME B30.9. For use with chain slings, refer to page 240 for sling ratings and page 245 for proper master link selection.

- Alloy Steel — Quenched and Tempered.
- Individually Proof Tested to values shown, with certification
- Proof Tested with 70% inside width special fixtures sized to prevent localized point loading per EN 1677-4, reference page 276.
- Forgings have a Product Identification Code (PIC) for material traceability, along with the size, the name Crosby or "CG".
- 347 master links are type approved to DNV Certification Notes 2.7-1- Offshore Containers. These Crosby master links are 100% proof tested and impact tested. The tests are conducted by Crosby and 3.1 test certification is available upon request.
- Engineered Flat for use with S-1325A coupler link.
- Meets or exceeds all requirements of ASME B30.26 including identification, ductility, design factor, proof load and temperature requirements. Importantly, these links meet other critical performance requirements including fatigue life, impact properties and material traceability, not addressed by ASME B30.26.

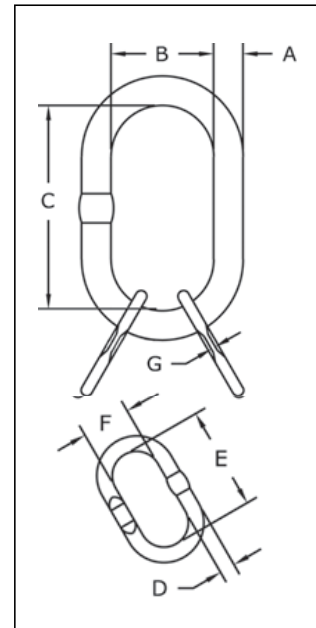

11/16" through 1-7/32" have Engineered Flat



## A-347 Welded Master Link Assembly with Engineered Flat

Size		A-347 Stock No.	Weight Each (lb)	Chain Size		WLL Based on Grade 8 Chain 60° Sling Angle (lb)*	Dimensions (in)							Engineered Flat Size for S-1325 (in)
(in)	(mm)			(in)	(mm)		A	B	C	D	E	F	G	
1/2	13/12	1257692	1.80	-	-	5300	.51	2.36	4.72	.47	3.35	1.77	.24	-
11/16	17/13	1257762	3.40	-	6	6500	.67	3.54	6.30	.51	4.72	2.36	.26	1/4
3/4	19/13	1257832	4.00	1/4	7	9100	.75	3.54	6.30	.51	4.72	2.36	.26	1/4
7/8	22/17	1257972	7.20	5/16	8	11700	.87	3.94	7.10	.67	6.30	3.54	.33	5/16
1-1/8	28/22	1258142	15.4	3/8	10	18400	1.10	5.71	10.83	.87	7.10	3.94	.41	3/8
1-7/32	31/25	1258182	20.8	1/2	13	31200	1.22	5.71	10.83	.98	8.10	4.53	.53	1/2
1-9/16	40/31	1258332	40.5	5/8	16	47000	1.57	6.30	11.80	1.22	10.63	5.50	-	**
1-3/4	45/36	1258402	58.2	3/4	20	73500	1.77	7.10	13.40	1.42	11.20	6.10	-	**
2	51/45	1258462	95.0	7/8	22	88900	2.00	7.50	13.80	1.80	13.40	7.10	-	**

\* Chain slings require that the Minimum Ultimate Load be 4 times the Working Load Limit. Refer to page 163 to determine products actual Ultimate Load. See chart on page 240 for other sling angles. \*\*There are no manufactured flats on links over 31mm (1 1/4)

# Grade 80 Latch Hooks



**S-314A**  
Clevis  
Chain Hook

- Hook is Forged Alloy Steel - Quenched and Tempered.
- Individually Proof Tested at 2-1/2 times the Working Load Limit with certification
- Integrated heavy duty latch.
- Large throat opening.
- Anti-fouling due to carefully designed contours.
- Meets ASTM A-952 for Grade 80 chain fittings
- Fatigue rated.
- "Look for the color Gold – Crosby Alloy Hooks."

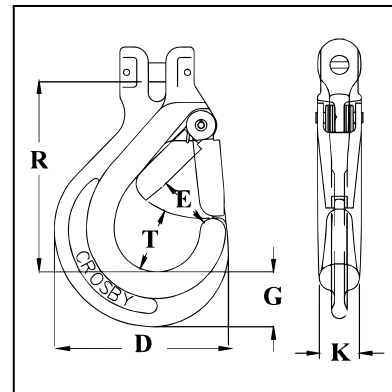

**Fatigue Rated**

## S-314A Clevis Chain Hook with Integrated Latch

Chain Size		S-314A Stock No.	Grade 8 Alloy Chain Working Load Limit (lb) 4:1*	Weight Each (lb)	Dimensions (in)						Replacement Latch Stock No.
(in)	(mm)				D	E	G	K	R	T	
-	6	1225020	2500	.69	2.60	.81	.79	.63	2.84	1.02	1291332
1/4 - 5/16	7 - 8	1225021	4500	1.53	3.50	1.08	1.10	.81	3.83	1.28	1291402
3/8	10	1225091	7100	2.84	4.35	1.42	1.16	.94	4.92	1.66	1291472
1/2	13	1225161	12000	5.17	5.45	1.52	1.67	1.16	5.64	1.94	1291542
5/8	16	1225162	18100	9.00	6.56	1.91	2.05	1.50	6.79	2.32	1291612

\* Ultimate Load is 4 times the Working Load Limit.

Chain & Accessories



**S-315A**  
Eye Chain Hook

- Hook is Forged Alloy Steel - Quenched and Tempered.
- Individually Proof Tested at 2-1/2 times the Working Load Limit with certification
- Crosby recommends grinding the WLL (which is 5:1 Design Factor) off the hook when using with Grade 80 chain.
- Integrated heavy duty latch.
- Large throat opening.
- Anti-fouling due to carefully designed contours.
- "Engineered Flat" for use with S-1325A Coupler Link.
- Meets ASTM A-952 for Grade 80 chain fittings
- Fatigue rated.
- "Look for the color Gold – Crosby Alloy Hooks."

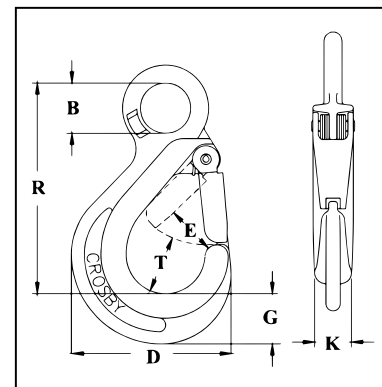

**Fatigue Rated**

## S-315A Eye Chain Hook with Integrated Latch

Chain Size		S-315A Stock No.	Grade 80 Alloy Chain Working Load Limit (lb) 4:1*	Working Load Limit for Wire Rope (Tons) 5:1	Weight Each (lb)	Dimensions (in)						Replacement Latch Stock No.	
(in)	(mm)					B	D	E	G	K	R		T
-	6	1029820	2500	1	.56	.79	2.60	.81	.79	.63	3.33	1.02	1291332
1/4 - 5/16	7 - 8	1029825	4500	2	1.31	1.10	3.50	1.08	1.10	.81	4.62	1.28	1291402
3/8	10	1029830	7100	3	2.60	1.42	4.35	1.42	1.16	.94	6.20	1.66	1291472
1/2	13	1029835	12000	5	4.70	1.81	5.45	1.52	1.67	1.16	7.33	1.94	1291542
5/8	16	1029840	18100	7	8.55	2.20	6.56	1.91	2.05	1.50	8.94	2.32	1291612

\* Ultimate Load is 4 times the Working Load Limit.





**S-4320**  
Replacement Latch Kit

- Heavy duty stamped latch interlocks with the hook tip.
- High cycle, long life spring.
- Can be made into a “Positive Locking” Hook when proper cotter pin is utilized.
- Latch kits shipped unassembled and individually packaged with instructions.

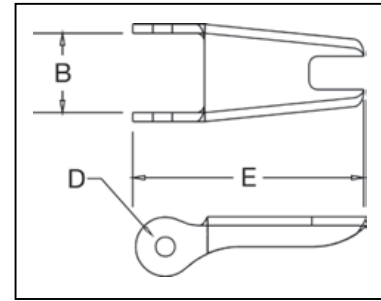

**IMPORTANT:** The new S-4320 Latch Kit will not fit the old style 319, 320 and 322 hooks



## S-4320 Replacement Latch Kit for 319N (new), 320N, 322N and 339N Hooks

Hook Size (t)			Hook ID Code	S-4320 Stock No.	SS-4320 Stock No.*	Weight Each (lb)	Dimensions (in)		
Carbon	Alloy	Bronze					B	D	E
3/4	1	.5	D	1096325	1097100	.03	.50	.15	1.44
1	1-1/2	.6	F	1096374	1097109	.04	.54	.17	1.56
1-1/2	2	1	G	1096421	1097118	.04	.63	.17	1.66
2	3	1.4	H	1096468	1097127	.06	.66	.17	1.91
3	5	2	I	1096515	1097136	.10	.83	.20	2.31
5	7	3.5	J	1096562	1097145	.15	1.04	.20	2.88
7-1/2	11	5	K	1096609	1097154	.28	1.25	.27	3.56
10	15	6.5	L	1096657	1097163	.33	1.35	.27	3.81
15	22	10	N	1096704	1097172	.84	1.66	.39	5.18

\* SS-4320 is Stainless Steel construction with cad plated steel nuts.

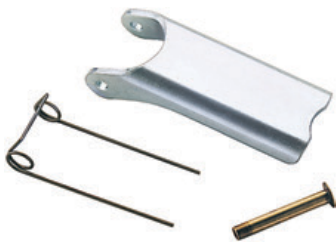

- To be used on A-327 and A-339 Grade 8 Sling Hooks.
- Latch Kits shipped unassembled and individually packaged with instructions.

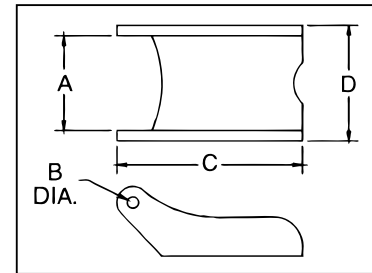

## S-4088 Alloy Hook Latch Kits

Hook Chain Size (in)	S-4088 Stock No.	Weight Each (lb)	Dimensions (in)			
			A	B	D	D
9/32 (1/4)	1090250	.06	.78	.16	2.03	.94
3/8	1090251	.14	1.03	.19	2.69	1.25
1/2	1090252	.15	1.03	.19	3.00	1.25
5/8	1090253	.15	1.03	.19	3.25	1.25
3/4	1090254	.15	1.53	.26	4.13	1.88
7/8	1090255	.15	1.53	.26	4.66	2.00



- Latch Kits shipped unassembled and individually packaged with instructions.
- For use only with Crosby L-1338 and L-1358 Grab Hooks (page 233).

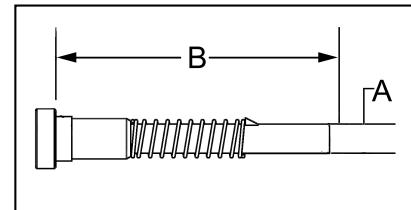

## S-4338 Grab Hook Latch Kits

Hook Size		S-4338 Stock No.	Weight Each (lb)	Dimensions (in)	
(in)	(mm)			A	B
1/4	7	1048426	.02	.18	1.59
5/16	8				
3/8	10	1048435	.02	.18	1.78
1/2	13	1048444	.04	.25	2.25
5/8	16	1048453	.07	.31	2.59



# Crosby®

## The Leader in Cargo Handling Solutions

As the leading innovator in the cargo handling industry, Crosby® continues to bowl over the competition with top-notch service, in-depth training, and time-tested expertise. Our unrivaled customer service and extensive product line encompass all aspects of cargo handling, such as:



**Ports, Terminals,  
& Distribution**



**On-Road  
Transportation**



**Maritime & Offshore  
Handling**



# CONNECT with CROSBY

---

*Follow the leader in rigging, lifting and securement*

---



**Crosby**<sup>®</sup>

#rigcrosby  
#knowtheload



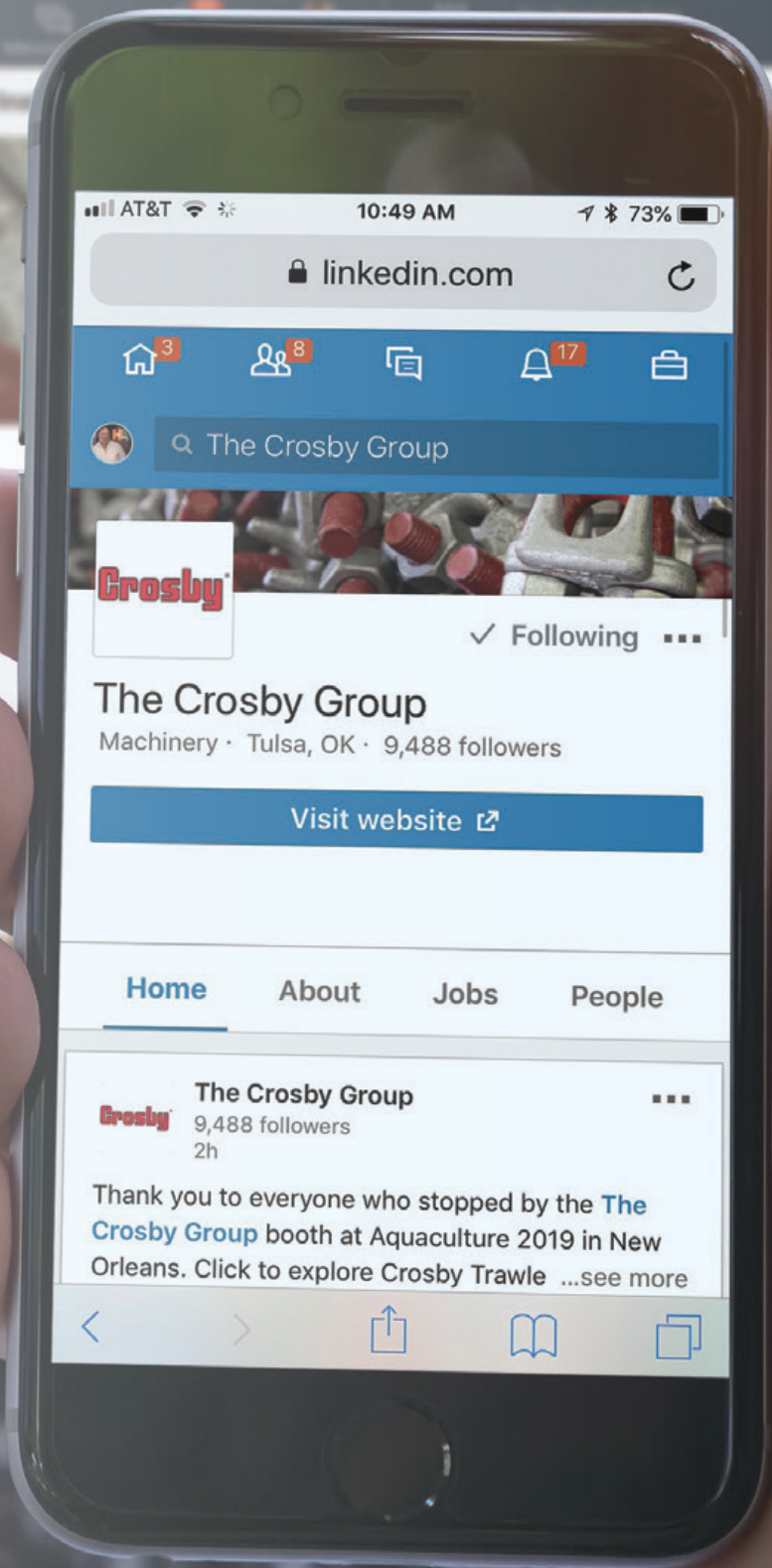

AT&T 10:49 AM 73%

linkedin.com

Home 3 Profile 8 Messages 17

The Crosby Group

**Crosby** ✓ Following

**The Crosby Group**  
Machinery · Tulsa, OK · 9,488 followers

[Visit website](#)

Home About Jobs People

**The Crosby Group** 9,488 followers · 2h

Thank you to everyone who stopped by the **The Crosby Group** booth at Aquaculture 2019 in New Orleans. Click to explore Crosby Trawle ...see more

Navigation icons: back, forward, share, bookmark, tabs



# YOU ASKED FOR IT — CROSBY DELIVERED

## The Painting of Our Platinum Line of Chain Fittings is Now Complete

The platinum color of the Crosby Lok-A-Loy® visually identifies the chain connector as Grade 100. The new finish extends the life of the product by providing added protection from exposure to harsh environments such as salt water and other corrosive substances. Adding a durable hard finish to our industry leading Lok-A-Loy® design is one more reason Crosby should be your choice for premium chain fittings and accessories.



Before

After

### Painted Crosby A-1337 Lok-A-Loys

- Improved corrosion resistance
- All sizes, 9/32" (7 mm) through 1-1/4" (32 mm) are Grade 100
- Locking system that provides for simple assembly and disassembly – no special tools needed
- Meets ASTM A-952-96 standards for Grade 100 fittings
- Individually proof tested at 2-1/2 times Working Load Limit with certification
- Forged alloy steel – Quenched and Tempered
- Fatigue rated

Crosby® 8/10™

Fatigue Rated®

"QT"  
QUENCHED & TEMPERED

Crosby®

[thecrosbygroup.com](http://thecrosbygroup.com)

# Crosby® Connecting Links



**A-336**  
Connecting Link

- Forged Alloy Steel - Quenched and Tempered.
- Individually Proof Tested at 2-1/2 times the Working Load Limit with certification
- Easy to assemble - see instructions on page 276.

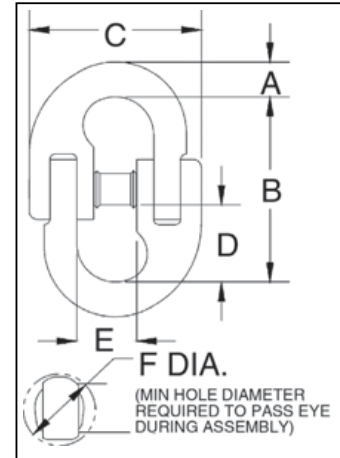

## A-336 LOK-A-LOY® 6 Connecting Link

Chain Size (in)	A-336 Stock No.	Working Load Limit (lb)*	Weight Each (lb)	Dimensions (in)					Diameter of Hole to Accept Link (in)
				A	B	C	D	E	
1/4	1014397	3250	.24	.31	2.06	1.69	.78	.78	.50
3/8	1014413	6600	.58	.45	2.72	2.31	1.06	1.09	.66
1/2	1014431	11300	1.20	.58	3.34	3.16	1.28	1.41	.88
5/8	1014459	16500	2.42	.78	3.91	3.94	1.56	1.69	1.06
3/4	1014477	23000	3.89	.89	4.84	4.44	1.97	2.00	1.19
7/8	1014495	28750	6.08	1.00	5.81	5.31	2.38	2.12	1.38
1	1014510	38750	7.03	1.08	6.48	6.07	2.84	2.55	1.47
1-1/4	1014538	57500	13.20	1.38	8.48	7.65	3.77	3.77	1.73

\* Ultimate Load is 4 times the Working Load Limit.



**NOTE:** The WLL of the A-336 is less than Grade 80 chain ratings. When using in Grade 80 chain slings, ASME B30.9c requires that the Working Load Limit of a sling must not exceed the lowest Working Load Limit of the components in the system.



**G-334**  
Replacement Link

- Forged Steel - Quenched and Tempered.
- Has larger inside dimensions making it easier to attach hooks or other fittings to the chain
- An exclusive Crosby product.
- After making connections, rivets must be peened.

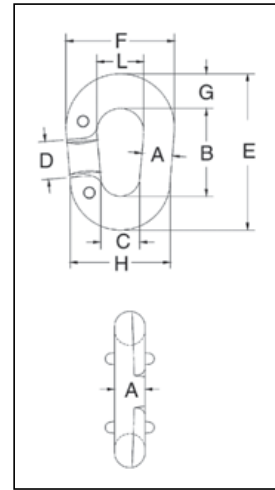

## G-334 Pear Shape “Missing Link”® Replacement Links

Chain Size (in)	Stock No. G-334 Galv.	Working Load Limit (lb)*	Weight Per 100 (lb)	Dimensions (in)								
				A	B	C	D	E	F	G	H	L
3/8	1013432	1850	25.00	.41	2.00	.56	.81	2.94	1.63	.47	1.38	.81
1/2	1013450	3300	50.00	.50	2.50	.69	1.00	3.63	2.00	.56	1.69	1.00
5/8	1013478	5000	75.00	.63	2.75	.81	1.06	4.00	2.38	.63	2.06	1.13
3/4	1013496	7100	125.00	.75	3.13	1.00	1.13	4.75	2.75	.81	2.50	1.25
7/8	1013511	9600	200.00	.88	3.69	1.25	1.38	5.56	3.25	.94	3.00	1.50

\* Ultimate Load is 4 times the Working Load Limit. \*\* Rivets Only - No interlocking lugs. † Has reinforced rivet holes. All sizes have countersunk rivet holes.  
Not Suitable for use with Grade 80 or Grade 100 chain and chain slings used in overhead lifting.



**G-335**  
Replacement Link

- Forged Steel - Quenched and Tempered.
- Integral rivets join the two halves.
- After making connections, rivets must be peened.

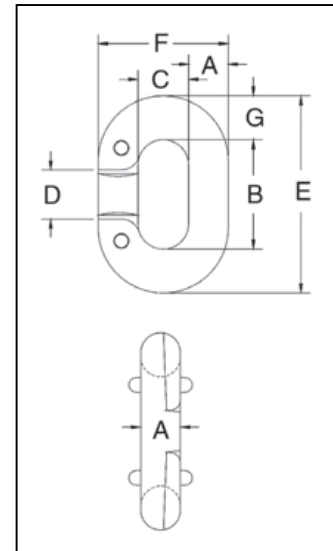

Meets or exceeds the performance requirements of Federal Specifications RR-C-271G, type II, except for those provisions required of the contractor. For additional information, see page 452.

## G-335 “Missing Link”® Replacement Links

Chain Size (in)	Stock No. G-335 Galv.	Working Load Limit (lb)*	Links Per Box	Weight Per 100 (lb)	Dimensions (in)						
					A	B	C	D	E	F	G
**1/4	1013110	1325	10	6.25	.28	.88	.44	.44	1.50	1.00	.31
**5/16	1013138	1950	10	12.50	.34	.94	.47	.47	1.69	1.16	.38
3/8	1013156	2750	10	20.00	.41	1.13	.56	.56	2.06	1.38	.47
7/16	1013174	3625	10	27.50	.47	1.28	.59	.59	2.34	1.53	.53
1/2	1013192	4750	10	37.50	.53	1.47	.66	.66	2.66	1.72	.59
5/8	1013236	7250	10	72.50	.66	1.81	.78	.81	3.31	2.09	.75
3/4	1013254	10250	10	122.50	.78	2.13	.94	1.06	3.88	2.50	.88
7/8	1013272	12000	Bulk	175.00	.91	2.50	1.13	1.13	4.50	2.94	1.00
† 1	1013290	15500	Bulk	250.00	1.03	2.75	1.25	1.25	5.00	3.31	1.13

\* Ultimate Load is 4 times the Working Load Limit. \*\* Rivets Only - No interlocking lugs. † Has reinforced rivet holes. All sizes have countersunk rivet holes.  
Not Suitable for use with Grade 80 or Grade 100 chain and chain slings used in overhead lifting.

# Crosby® Connecting Links



**S-247**  
Double Clevis Link

- All pins Alloy Steel - Quenched and Tempered.
- Body is forged and heat treated carbon steel.
- Designed for linking all popular sizes of Grade 3 and Grade 4 chain to rings, end links, eye hooks, pad eyes, tractor eye bolts, etc.
- Features quick and easy assembly.

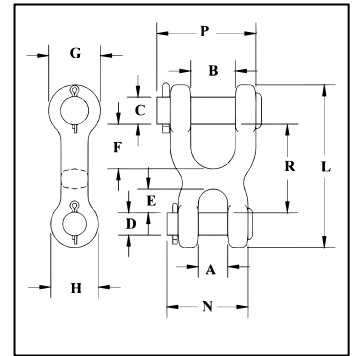

## S-247 Double Clevis Link

Chain Size (in)	S-247 Stock No.	Working Load Limit (lb)*	Weight Each (lb)	Dimensions (in)											
				A	B	C	D	E	F	G	H	L	N	P	R
1/4	1013021	2600	.38	.50	.75	.50	.31	.38	.75	1.00	.81	2.81	1.38	1.66	1.50
5/16-3/8	1013049	5400	.81	.56	1.00	.63	.44	.47	1.00	1.19	1.00	3.53	1.75	2.25	1.91
7/16	1013067	7200	1.25	.69	1.13	.69	.56	.59	1.09	1.31	1.19	4.06	2.00	2.50	2.19
1/2	1013085	9200	1.56	.81	1.25	.75	.63	.68	1.25	1.44	1.31	4.53	2.25	2.75	2.47

\* Ultimate Load is 4 times the Working Load Limit.

Not Suitable for use with Grade 80 or Grade 100 chain and chain slings used in overhead lifting.



**S-249**  
Twin Clevis Link

- Available in three popular sizes.
- Body is forged and heat treated carbon steel.
- All pins Alloy Steel - Quenched and Tempered.
- Features quick and easy assembly.
- Twin Clevis design provides a variety of uses and can be used with Grade 3, Grade 4 and Grade 7 chain.

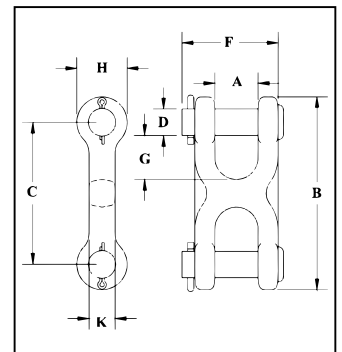

## S-249 Twin Clevis Link

Chain Size (in)	S-249 Stock No.	Working Load Limit (lb)*	Weight Each (lb)	Dimensions (in)							
				A	B	C	D	F	G	H	K
1/4-5/16	1012861	4700	.31	.47	2.50	1.56	.38	1.31	.43	.94	.50
3/8	1012889	6600	.44	.53	2.81	1.81	.44	1.53	.50	1.00	.56
7/16-1/2	1012905	11300	.98	.65	3.62	2.31	.56	1.91	.63	1.31	.81

\* Ultimate Load is 4 times the Working Load Limit.

Not Suitable for use with Grade 80 or Grade 100 chain and chain slings used in overhead lifting.

Chain & Accessories





**H-330 / A-330**  
Clevis Grab Hook

- Forged Steel - Quenched and Tempered.
- Design factor is 4:1.
- Features quick and easy assembly.
- H-330 designed for Grade 4 chain.
- A-330 designed for Grade 7 chain.

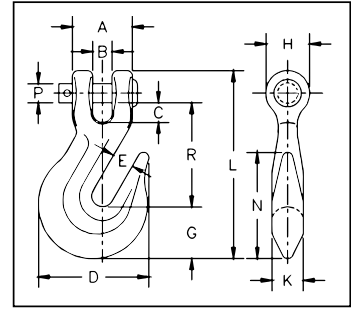

**H-330 / A-330 Clevis Grab Hooks**

Chain Size (in)	Stock No.		Working Load Limit (lb)		Weight Each (lb)	Dimensions (in)											
	H-330 Carbon	A-330 Alloy*	H-330 Carbon	A-330 Alloy		A	B	C	D	E	G	H	K	L	N	P	R
1/4	1027105	1027249*	2600	3500	.36	1.00	.32	.31	1.81	.34	.88	.72	.47	3.05	1.75	.31	1.64
5/16	1027123	1027267*	3900	4700	.62	1.22	.43	.36	2.12	.44	.97	.91	.59	3.66	2.06	.38	2.02
3/8	1027141	1027285*	5400	7100	1.00	1.42	.48	.49	2.53	.50	1.17	1.00	.72	4.42	2.34	.44	2.41
7/16	1027169	1027301	7200	8750	1.31	1.66	.66	.62	3.09	.56	1.31	1.13	.69	4.94	2.66	.56	2.75
1/2	1027187	1027329*	9200	12000	2.22	1.88	.57	.51	3.56	.66	1.53	1.25	.78	5.72	2.97	.63	3.19
5/8	1027203	1027347	13000	18100	4.41	2.31	.71	.67	4.39	.78	1.78	1.56	1.09	6.83	4.31	.75	4.09
3/4	1027221	1027365	20200	24700	6.50	2.62	.94	.94	5.22	.94	2.13	1.88	1.31	8.13	5.09	.88	4.63

\* These A-330 hooks are forged with an "8" designating Grade 80, and are suitable for use with Grade 8 chain in overhead lifting applications as long as hook is proof-tested as part of the chain sling assembly or as an individual component per ASME B30.9. We recommend the use of the A-338 which is proof tested and supplied with a proof test certificate



**H-323 / A-323**  
Eye Grab Hook

- Forged Steel - Quenched and Tempered.
- Design Factor is 4:1.
- H-323 designed for Grade 4 chain.
- A-323 designed for Grade 7 chain.

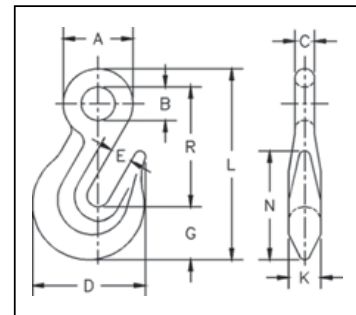

**H-323 / A-323 Eye Grab Hooks**

Chain Size (in)	Stock No.		Working Load Limit (lb)		Weight Each (lb)	Dimensions (in)									
	H-323 Carbon	A-323 Alloy*	H-323	A-323		A	B	C	D	E	G	K	L	N	R
1/4	1026204	1026384*	2600	3500	.28	1.09	.53	.31	1.81	.34	.88	.47	3.05	1.75	1.88
5/16	1026222	1026400*	3900	4700	.45	1.31	.62	.38	2.12	.44	.97	.59	3.59	2.06	2.28
3/8	1026240	1026428*	5400	7100	.79	1.56	.75	.44	2.53	.50	1.17	.72	4.28	2.34	2.69
1/2	1026286	1026464*	9200	12000	1.75	1.94	.88	.53	3.56	.66	1.53	.78	5.44	2.97	3.38
5/8	1026302	1026482*	13000	18100	3.25	2.48	1.16	.66	4.41	.79	1.89	1.16	6.82	4.25	4.25
3/4	1026320	1026507	20200	24700	5.94	2.88	1.38	.75	5.22	.94	2.13	1.31	8.06	5.09	5.16

\* These A-330 hooks are forged with an "8" designating Grade 80, and are suitable for use with Grade 8 chain in overhead lifting applications as long as hook is proof-tested as part of the chain sling assembly or as an individual component per ASME B30.9. We recommend the use of the A-338 which is proof tested and supplied with a proof test certificate

# Crosby® Slip Hooks



**H-331 / A-331**  
Clevis Slip Hook

- Forged Carbon Steel or Forged Alloy Steel – Quenched and Tempered.
- All pins are Alloy Steel – Quenched and Tempered.
- Not suitable for use with Grade 80 chain and chain slings used in overhead lifting. For slings or lifting chains, Grade 80 or 100 alloy components are recommended.

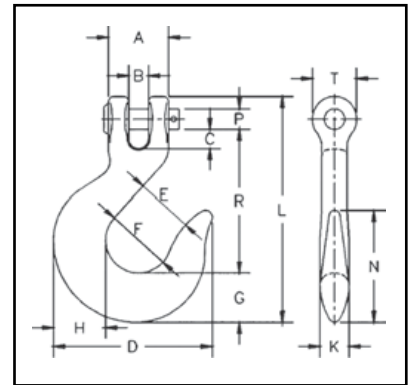

## H-331 / A-331 Clevis Slip Hooks

Chain Size (in)	Stock No.		Working Load Limit (lb)*		Weight Each (lb)	Dimensions (in)													
	H-331 Carbon	A-331 Alloy	H-331 Carbon	A-331 Alloy		A	B	C	D	E	F	G	H	K	L	N	P	R	T
1/4	1027383	1027524	1950	2750	.55	1.06	.32	.29	2.75	.94	1.19	.81	.88	.50	3.95	2.13	.31	2.58	.81
5/16	1027409	1027542	2875	4300	.79	1.22	.43	.34	3.06	1.06	1.25	.94	1.00	.56	4.52	2.25	.38	2.87	.97
3/8	1027427	1027560	4000	5250	1.21	1.38	.45	.44	3.63	1.31	1.50	1.13	1.19	.66	5.15	2.56	.44	3.25	1.06
7/16	1027445	1027588	5000	7000	2.06	1.73	.59	.60	4.34	1.56	1.81	1.38	1.44	.81	5.97	3.06	.56	3.70	1.19
1/2	1027463	1027604	6500	9000	2.75	1.88	.57	.53	4.81	1.69	1.94	1.56	1.63	.91	6.53	3.44	.63	4.00	1.31
5/8	1027481	1027622	9250	13500	4.75	2.31	.71	.71	5.63	2.00	2.38	1.81	1.94	1.09	7.89	4.00	.75	4.94	1.56
3/4	–	1027640	–	19250	11.28	3.19	1.18	1.29	7.38	2.50	3.00	2.38	2.50	1.44	10.02	5.06	1.00	6.09	2.09

\* Ultimate Load is 4 times the Working Load Limit.

Chain & Accessories

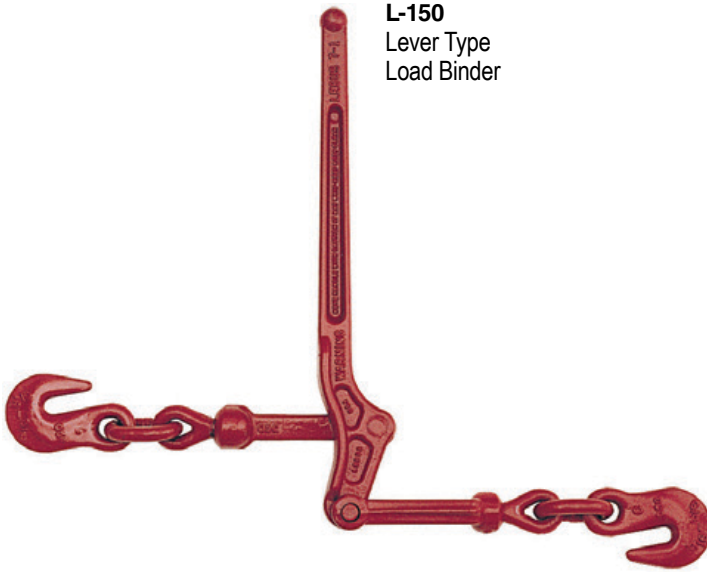

**L-150**  
Lever Type  
Load Binder

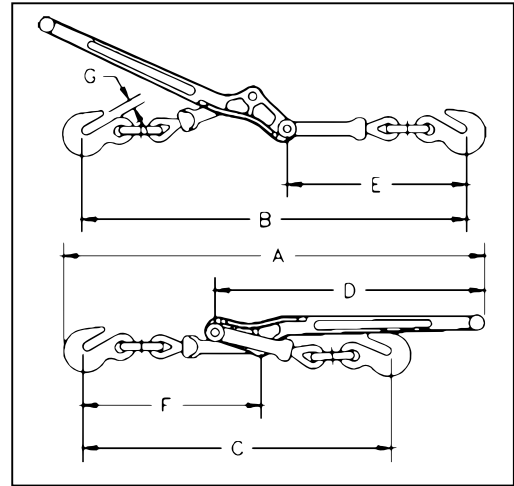

- Extra heavy construction at leverage point to prevent spreading. Heel of binder toggles away from load, permitting easy release.
- Ball and socket swivel joints at hook assemblies permit a straight line pull.
- Binders shown with Proof Loads have been individually proof tested to values shown, prior to shipment.
- Meets or exceeds requirements of US DOT FMCSA Part 393 Subpart I.

Load Rated®



**SEE APPLICATION AND WARNING INFORMATION**  
On Pages 271  
Para Español: [www.thecrosbygroup.com](http://www.thecrosbygroup.com)

**L-150 Standard Lever Type Load Binders**

Model	Stock No.	Std. Pkg.	Min-Max Chain Size (in)	Working Load Limit (lb)	Proof Load (lb)	Ultimate Load (lb)	Weight Each (lb)	Handle Length (in)	Take Up (in)	Dimensions (in)						
										A	B	C	D	E	F	G
7-1	1048128	4	5/16-3/8	5400	10800	19000	7.02	16.00	4.50	24.13	22.13	17.88	16.00	10.38	10.38	.50
A-1	1048146	4	3/8-1/2	9200	18400	33000	12.47	18.69	4.50	28.75	25.75	21.25	18.69	12.31	12.38	.63
C-1	1048164	4	1/2-5/8	13000	26000	46000	19.68	21.00	4.75	31.25	29.75	25.00	21.00	14.63	13.75	.72

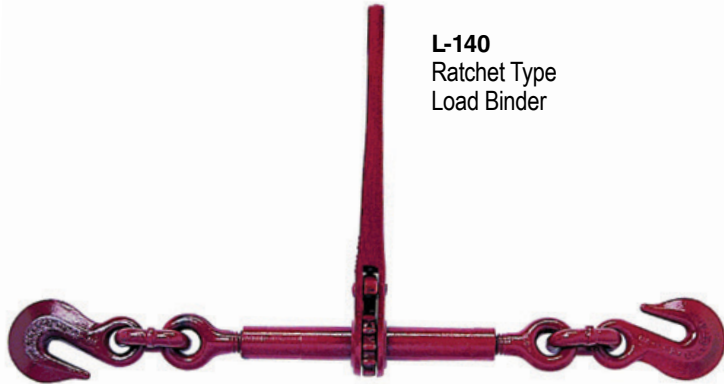

**L-140**  
Ratchet Type  
Load Binder

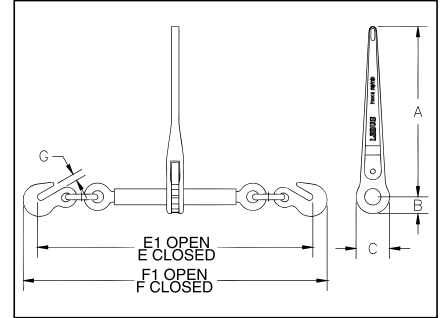

- Upgraded for use with Grades 70, 80 and 100 Chain.
- Utilizes standard Crosby A-323 Alloy Eye Grab Hooks.
- New design “one piece” forged handle.
- Continuous take-up feature provides finite adjustment to tie down load.
- One piece assembly, no bolts or nuts to loosen.
- Ratchet spring is rust proofed.
- All load bearing or holding parts forged.
- Easy operating positive ratchet.
- Binders shown with Proof Loads have been individually proof tested to values shown, prior to shipment.
- Meets or exceeds requirements of US DOT FMCSA Part 393 Subpart I.



**Load Rated**

## L-140 Standard Ratchet Type Load Binders (Meets or exceeds requirements of US DOT FMCSA Part 393 Subpart I.)

Model	Stock No.	Min-Max Chain Size (in)	Working Load Limit (lb)*	Proof Load (lb)	Weight Each (lb)	Handle Length (in)	Barrel Length (in)	Take Up (in)	Dimensions (in)							
									A	B	C	E	E1	F	F1	G
R-7 **	1048404	5/16-3/8	8800	17600	12.11	14	10	8.0	14.00	1.38	2.75	22.94	30.94	25.13	33.13	.50
R-A **	1048422	3/8-1/2	15000	30000	14.70	14	10	8.0	14.00	1.38	2.75	25.25	33.25	27.63	35.63	.63
R-C ***	1048440	1/2-5/8	16000	32000	14.55	14	10	8.0	14.00	1.38	2.75	26.38	34.38	29.44	37.44	.72

\* Ultimate Load is 3 times the Working Load Limit. \*\* Matches the Working Load Limit of Grade 100 chain for both sizes. \*\*\* Matches the Working Load Limit of Grade 100 chain for 1/2" size.

Chain & Accessories



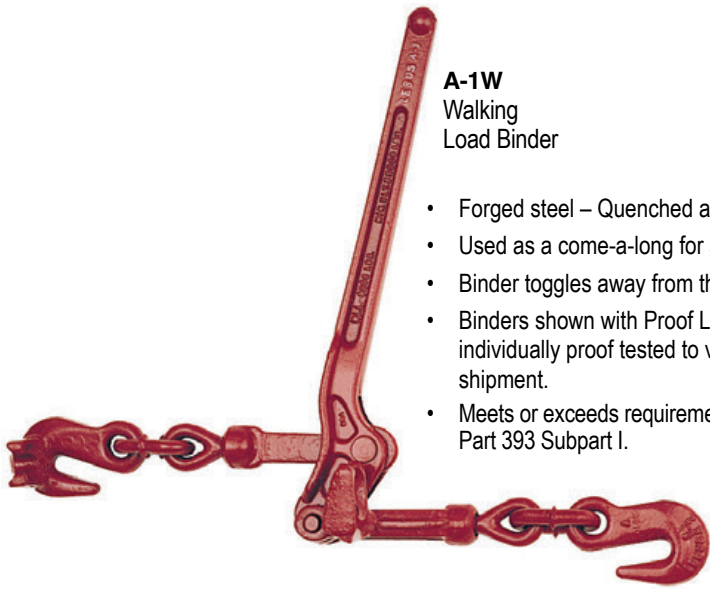

- Forged steel – Quenched and Tempered.
- Used as a come-a-long for short take-up on chain.
- Binder toggles away from the load.
- Binders shown with Proof Loads have been individually proof tested to values shown, prior to shipment.
- Meets or exceeds requirements of US DOT FMCSA Part 393 Subpart I.

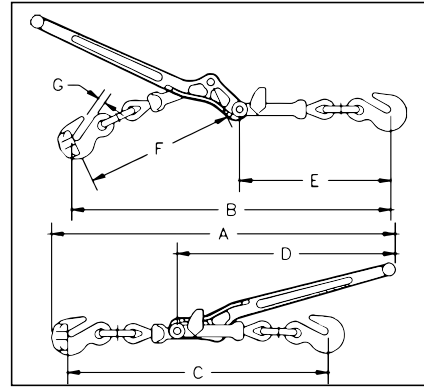

**SEE APPLICATION AND WARNING INFORMATION**  
 On Pages 271  
 Para Español: www.thecrosbygroup.com



A-1W Walking Load Binders

Model	Stock No.	Chain Size (in)	Working Load Limit (lb)	Proof Load (lb)	Ultimate Load (lb)	Weight Each (lb)	Handle Length (in)	Dimensions (in)						
								A	B	C	D	E	F	G
A-1W	1048388	1/2 only	9200	18400	33000	13.10	18.69	28.75	25.75	21.25	18.69	12.31	12.38	.63

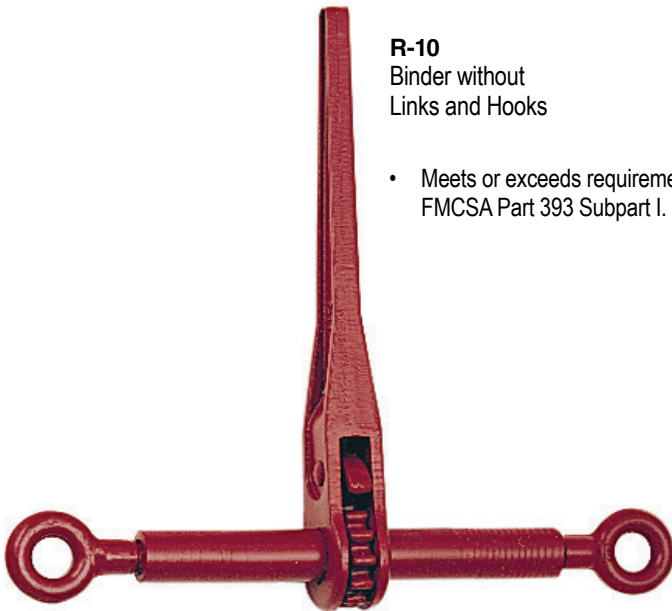

- Meets or exceeds requirements of US DOT FMCSA Part 393 Subpart I.

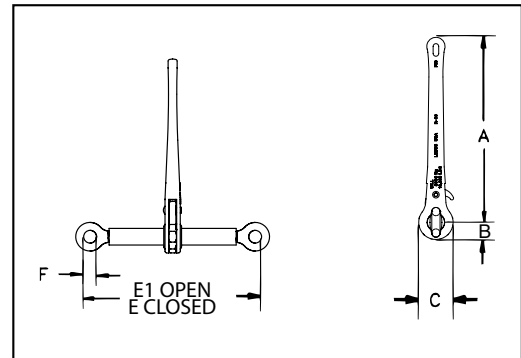

R-10 Binder without Links and Hooks

Model	R-10 Stock No.	Working Load Limit (lb)*	Weight Each (lb)	Handle Length (in)	Barrel Length (in)	Take Up (in)	Dimensions (in)					
							A	B	C	E	E1	F
R-10	1048468	16000	8.04	14	10	8.0	14	1.38	2.75	14	22	1.00

\* Ultimate Load is 3 times the Working Load Limit.

# Lebus® Load Binders

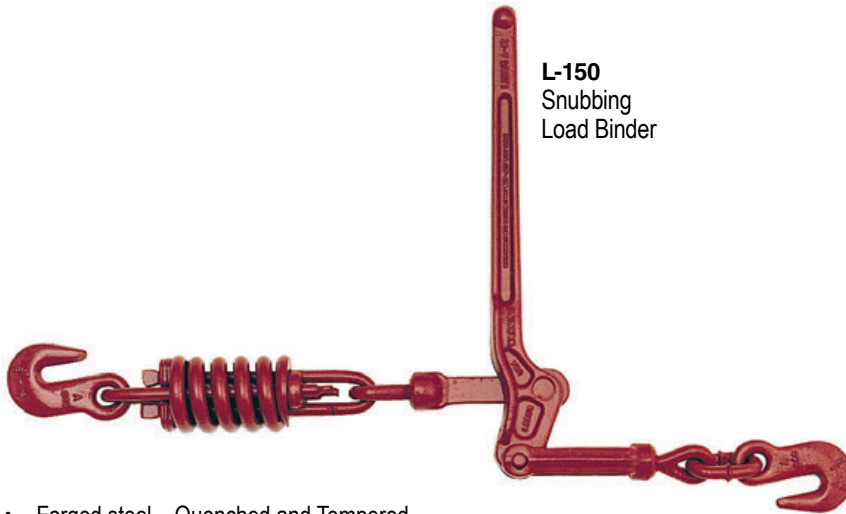

**L-150**  
Snubbing  
Load Binder

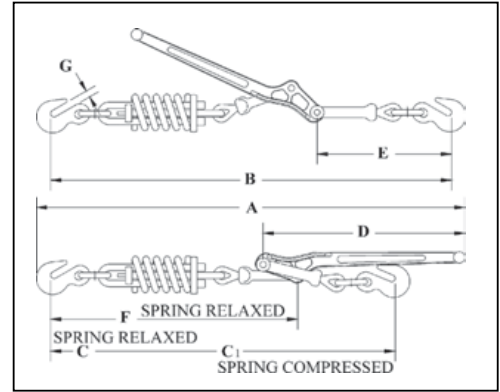

- Forged steel – Quenched and Tempered.
- Spring cushion for load protection, cushions shock and sway.
- Binder toggles away from the load.

**SEE APPLICATION AND WARNING INFORMATION**  
On Pages 271  
Para Español: [www.thecrosbygroup.com](http://www.thecrosbygroup.com)



## L-150 Snubbing Load Binders

Model	Stock No.	Min-Max Chain Size (in)	Working Load Limit (lb)	Ultimate Load (lb)	Weight Each (lb)	Handle Length (in)	Take Up (in)	Compression Strength of Spring (lb)	Dimensions (in)							
									A	B	C	C1	D	E	F	G
7-12	1048280	5/16 - 3/8	5400	16000	11.25	16.00	4.25	2300	32.75	30.75	28.00	26.50	16.00	10.38	19.00	.50
A-12	1048306	3/8 - 1/2	9200	20000	18.69	18.50	4.50	3300	37.19	34.00	29.50	30.44	18.69	12.31	20.88	.63

Chain & Accessories



**C-188 Spectrum 8®**  
Alloy Boomer Chain

- Heat treated alloy steel.
- Ends fitted with Crosby A-330 Quenched and Tempered alloy clevis grab hook.
- Finish – Self Colored.
- Meets or exceeds requirements of US DOT FMCSA Part 393 Subpart I.

## C-188 Spectrum 8® Alloy Boomer Chains

Chain Size (in)	C-188 Stock No.	Working Load Limit (lb)	Standard Length (ft)	Weight Each (lb)
3/8	279889	7100	20	30.28
1/2	279898	12000	20	54.04



**L-180**  
Winchline Tail Chain

- Hooks are Forged – Quenched and Tempered.
- Individually Proof Tested.
- Spectrum 8® Alloy Steel from 3/4" through 1-1/4" (20 - 32mm).
- Meets or exceeds requirements of US DOT FMCSA Part 393 Subpart I.

## L-180 Winchline Tail Chain

Wire Rope Diameter (in)*	L-180 Stock No.	Working Load Limit (lb)†	Length (in)	No. of Links	Weight Each (lb)
5/16 - 3/8	1091473	5400	18	11	3.0
1/2 - 5/8	1091482	13000	18	7	6.2
3/4 - 7/8	1091511	34200	24	8	18.2
1 - 1-1/8	1091516	47700	18	5	21.2
1 - 1-1/8	1091525	47700	24	7	23.3
1-1/4	1091532	72300	24	5	40.0

\* Recommended for IPS or XIP (EIP), RRL, FC or IWRC wire rope. † Ultimate Load is 3.5 times the Working Load Limit.

# Replacement Hooks for Chain Hoists



**O-318**  
Chain Nest Hook



**O-319**  
Chain Nest Hook

- Available in Working Load Limits of 1.7, 2.3, and 4.2 Tons.
- Fits 1/4" thru 9/16" hoist chain.
- Hooks are forged alloy steel – Quenched and Tempered.
- Chain connecting pin is alloy.
- A Product Identification Code (PIC) for material traceability, the size, and the name Crosby or "CG" are forged or stamped onto each hook and swivel assembly (chain nest).
- Entire assembly is zinc plated.
- Fitted with ball bearings and is suitable for frequent rotation under load.
- Repair kit available consisting of bearing and spring pin.
- O-318 Hooks utilize Crosby SHUR-LOC® "Positive Locking" hooks. Latch is Self-Locking when hook is loaded.
- O-319 Hooks utilize Crosby® standard 319 Shank Hooks with the registered **QUIC-CHECK**® marking.
- Replacement latch kits are available.
- Use in corrosive environment requires shank and nut inspection in accordance with ASME B30.10-1.10.4(b)(5)(c).

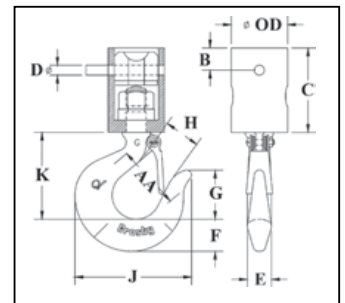
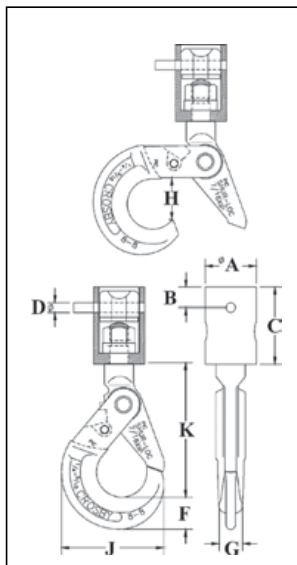

**SEE APPLICATION AND WARNING INFORMATION**  
 0-318 On Pages 272-273  
 0-319 On Pages 142-143  
 Para Español: [www.thecrosbygroup.com](http://www.thecrosbygroup.com)

Chain & Accessories

## O-318 Chain Nest Hooks

Chain Size (in)	O-318 Stock No.	Working Load Limit (Tons)*	Weight Each (lb)	Dimensions (in)									
				A	B	C	D	F	G	H	J	K	
1/4 - 9/32	1098409	1.7	3.50	1.75	.70	2.62	.31	1.10	.81	1.46	3.50	4.59	
5/16 - 3/8	1098427	2.3	6.00	2.13	.70	3.19	.38	1.15	.94	1.83	4.35	5.65	
3/8 - 7/16	1098445	4.2	13.75	3.00	1.00	4.38	.50	1.66	1.16	2.11	5.45	7.06	
1/2 - 9/16	1098463	4.2	13.75	3.00	1.00	4.38	.63	1.66	1.16	2.11	5.45	7.06	

\* Ultimate Load is 4 times the Working Load Limit.

## O-319 Chain Nest Hooks

Chain Size (in)	O-319 Stock No.	Working Load Limit (Tons)*	Weight Each (lb)	Dimensions (in)										
				OD	AA	B	C	D	E	F	G	H	J	K
1/4 - 9/32	1098312	1.7	2.55	1.75	2.00	.70	2.62	.31	.75	1.00	1.53	1.00	3.62	2.69
5/16 - 3/8	1098334	2.3	4.00	2.13	2.00	.70	3.19	.38	.84	1.12	1.72	1.12	4.09	3.06
3/8 - 7/16	1098356	4.2	10.00	3.00	2.50	1.00	4.38	.50	1.12	1.44	2.12	1.34	4.84	3.78
1/2 - 9/16	1098378	4.2	10.00	3.00	2.50	1.00	4.38	.63	1.12	1.44	2.12	1.34	4.84	3.78

\* Ultimate Load is 4 times the Working Load Limit.



## Replacement Hooks for Chain Hoists



- Available in Working Load Limits of 1.7, 2.3, and 4.2 Tons.
- Fits 1/4" through 9/16" hoist chain.
- Hooks are forged alloy steel - Quenched and Tempered.
- A Product Identification Code (PIC) for material traceability, the size, and the name Crosby or "CG" are forged or stamped onto each hook and swivel assembly (chain nest).
- Hooks utilize Crosby standard 319 Shank Hooks with the registered **QUIC-CHECK®** marking.
- Suitable for frequent rotation under load.
- Use in corrosive environment requires shank and nut inspection in accordance with ASME B30.10-1.10.4(b)(5)(c).

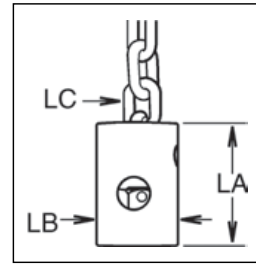

### Link Chain Nest

- **BL-O** – with self-closing gate. • **BL-P** – with manual-closing gate. • With ball-bearing swivel; attaches to chain by alloy pin.

Hook Size	BL-O Stock No.	BL-P Stock No.	Gate Type	Working Load Limit (Tons)*	Weight Each (lb)	Dimensions (in)		
						LA	LB	LC
4: 1/4 - 9/32	1051409	1051508	PIN-LOK	1.70	2.5	2.65	1.75	1/4 - 9/32
5: 5/16 - 3/8	1051442	1051541	ROLLOX	2.30	4.5	3.00	2.25	5/16 - 3/8
7: 3/8 - 7/16	1051464	1051563	ROLLOX	4.20	11.0	4.38	3.00	3/8 - 9/16
7: 1/2 - 9/16	1051486	1051585	ROLLOX	4.20	11.0	4.38	3.00	3/8 - 9/16

\* Ultimate Load is 4 times the Working Load Limit.



- Open Swivel Bail for attachment to link chain.
  - **BL-E** – with self-closing gate. • **BL-G** – with manual-closing gate.
- Suitable for infrequent, non-continuous rotation under load.
- Use in corrosive environment requires shank and nut inspection in accordance with ASME B30.10-1.10.4(b)(5)(c).

### Open Swivel Bail

Hook Size	BL-E Stock No.	BL-G Stock No.	Gate Type	Working Load Limit (Tons)*	Weight Each (lb)	Dimensions (in)			
						UA	UB	UC	UD
3	1051607	1051706	PIN-LOK	1.40	1.8	2.08	2.31	.52	.38
4	1051618	1051717	PIN-LOK	1.70	2.1	2.14	2.31	.52	.38
5	1051629	1051728	ROLLOX	2.30	3.2	2.56	2.63	.62	.44

\* Ultimate Load is 4 times the Working Load Limit.

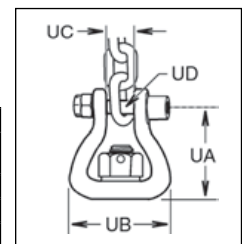

# Crosby® S-4338 Pin Latch

## WARNING & APPLICATION INSTRUCTIONS



S-4338 Pin Latch

### Important Safety Information Read and Follow

- Always inspect hook and pin latch before using.
- Never use a pin latch that is distorted or bent.
- Always make sure internal spring will force the pin latch forward closing throat opening of grab hook. (See Figure 1).
- When a Pin Latch is provided, it is designed to retain loose chain under slack condition.
- Always make sure hook supports the load. The pin latch must never support the load. (See Figure 1, 2, 3 and 4).
- Pin latch is not intended to be an anti-fouling device.
- Recommended for use with Crosby L-1338 or L-1358 Grab Hooks.

### Important – Instructions for Assembling

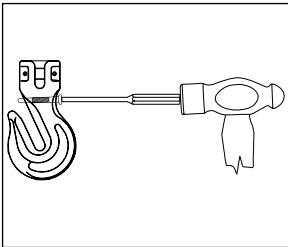

**Step 1:** Using a hammer and the correct roll-pin punch per chart on the right, drive the old latch pin assembly out of hook.

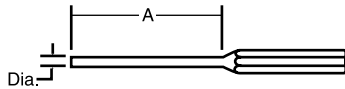

Hook Size (in)	Hook Size (mm)	Punch Dia. (in)	A (in)
1/4	7	7/32	3
5/16	8	7/32	3
3/8	10	7/32	3
1/2	13	5/16	4
5/8	16	3/8	4

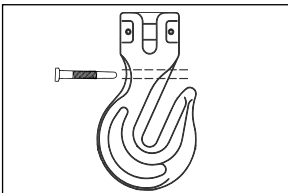

**Step 2:** Insert new S-4338 pin assembly into hook.

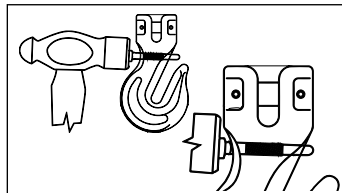

**Step 3:** Using hammer, tap lightly on latch pin head until guide bushing shoulder touches hook.

## ⚠ WARNING

- Loads may disengage from hook if proper procedures are not followed.
- A falling load may cause serious injury or death.
- Hook must always support the load. The load must never be supported by the pin latch.
- See OSHA Rule 1926.1431(g)(1)(i)(A) and 1926.1501(g)(4)(iv)(B). A hook and this style latch must not be used for lifting personnel.
- Read and understand these instructions before using hook and pin latch.

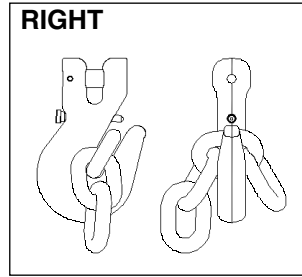

Figure 1

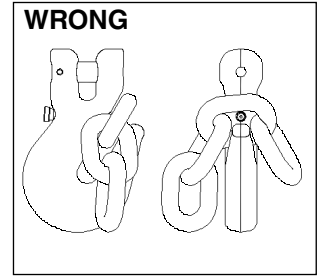

Figure 2

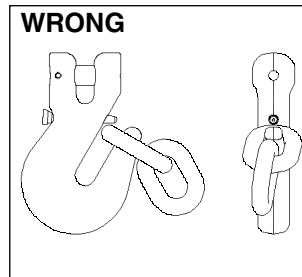

Figure 3

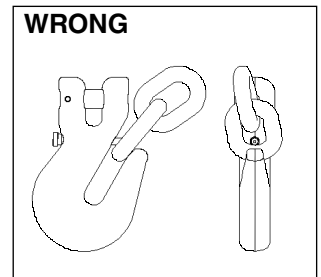

Figure 4

## ALLOY STEEL CHAIN SLINGS AND CROSBY ELIMINATOR®

### WARNING SELECTION, USE & APPLICATION INFORMATION



#### ⚠ WARNING

- Loads may disengage from sling if proper rigging procedures and inspection are not followed.
- A falling load may cause serious injury or death.
- Inspect sling for damage before each use.
- Do not attempt to use sling above rated load and angle upon which it is based.
- Consult sling load chart for capacity reduction due to sling angle or type of hitch used.
- Read and understand these instructions before using sling.

#### IMPORTANT SAFETY INFORMATION

##### Read and Follow

These warnings and instructions are applicable to alloy chain slings produced from Crosby Grade 8 (80) and Grade 10 (100) chain and components.

- Only alloy chain, grade 80 (Crosby Spectrum 8®), or grade 100 (Crosby Spectrum 10®), should be used for overhead lifting applications.
- Working Load Limit (WLL) is the maximum load in pounds which should ever be applied to chain, when the chain is new or in “as new” condition, and when the load is uniformly applied in direct tension to a straight length of chain.
- Working Load Limit (WLL) is the maximum working load for a specific minimum sling angle, measured from the horizontal plane. The minimum sling angle and Working Load Limit is identified on the sling.
- The Working Load Limit or Design factor may be affected by wear, misuse, overloading, corrosion, deformation, intentional alterations, sharp corner cutting action diameter of curvature over which the sling is used (D/d) and other use conditions.
- Shock loading and extraordinary conditions must be taken into account when selecting alloy chain slings.
- See OSHA Regulation for Slings 1910.184, ASME B30.9-“SLINGS”; ASME B30.10-“HOOKS”; and ASME B30.26 “RIGGING HARDWARE” for additional information.

ASME B30.9 requires a designated person inspect each new sling and attachments prior to initial use, as well as the user or other designated person perform a visual inspection on a sling each day it is used. In addition, a periodic inspection shall be performed by a designated person at least annually, and shall maintain a record of the last inspection. For further inspection information, see Chain Inspection section of this document, or refer to ASME B30.9-1.9.

#### CAUSE FOR REMOVAL FROM SERVICE

A sling shall be removed from service if any of the following are visible on chain or attachments:

- Wear, nicks, cracks, breaks, gouges, stretch, bend, weld

splatter, discoloration from excessive temperature, or throat openings of hooks.

- Chain links and attachments that do not hinge freely to adjacent links.
- Latches on hooks, if present, that do not hinge freely, seat properly or show evidence of permanent distortion.
- Excessive pitting or corrosion.
- Missing or illegible sling identification.
- Makeshift fasteners, hooks, or links formed from bolts, rods, etc.
- Mechanical coupling links in the body of the chain.
- Other damage that would cause a doubt as to the strength of the chain.

#### OPERATING PRACTICES

- The weight of the load must be known, calculated, estimated or measured. The loading on the slings will depend on where the center of gravity is located.
- Select sling having suitable characteristics for the type of load, hitch and environment.
- Slings shall not be loaded in excess of the rated capacity.
- Consideration shall be given to the sling load angle which affects rated capacity. (See load chart Table 4 for Grade 100 (SPECTRUM 10®) and Table 5 for Grade 80 (SPECTRUM 8®).
- Never rig a sling with an angle less than 30 degrees to horizontal.
- Slings in a basket hitch should have the load balanced to prevent slippage.
- The sling shall be hitched in a manner providing control of the load.
- Never side load, back load, or tip load a hook.
- Always make sure the hook supports the load. The latch must never support the load.
- Read and understand Crosby hook and hook latch Warnings and Application Instructions.
- For two legged slings with angles greater than 90 degrees, use an intermediate link such as a master link or bolt type shackle to collect the legs of the slings. The intermediate link can be placed over the hook to provide an in-line load on the hook. This approach must also be used when using slings with three or more legs.
- When using chain slings in choker applications, the Working Load Limit must be reduced by 20%. Crosby recommends a minimum angle of choke of 120 degrees (see Figure 1). Consult the manufacturer when planning to use an angle of choke less than 120 degrees. If Crosby A-1338 Cradle Grab hooks are used at the minimum angle of choke of 120 degrees, the full sling rated WLL can be utilized.
- When using chain slings in basket applications where the D/d (see figure 2) is less than 6, the rated load must be reduced by the values given in Table 1. This reduction does not eliminate the need to protect chain slings against damage caused by contact with edges, corners, or protrusions. Do not use a chain sling with a D/d that is less than two.



Figure 1

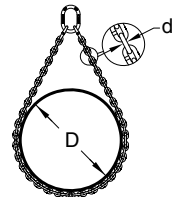

Figure 2

- In shortening applications, a 20% reduction of the Working Load Limit is required except when using the Crosby A-1338 Cradle Grab Hooks, S-1311 Chain Shortener Link, the A-1355 Chain Choker Hook in conjunction with the S-1325 Chain Coupler Link, or the Crosby ELIMINATOR® shortener link. They can be used without any reduction to the Working Load Limit.

- Slings should always be protected from being damaged by sharp corners.
- Slings should not be dragged on the floor or over abrasive surfaces.
- Chain sling links should not be twisted or kinked.
- Slings should not be pulled from under loads if the load is nesting on the sling.
- Slings that appear to be damaged should not be used unless inspected and accepted by designated person.
- All portions of the human body should be kept from between the sling and the load, and from between the sling and the crane hook or hoist hook.
- Personnel shall stand clear of the suspended load.
- Personnel shall not ride the sling.
- Shock loading should be avoided.
- Twisting or kinking the legs (branches) should be avoided.
- During lifting, with or without the load, personnel should be alert for possible snagging.
- When using a basket hitch, the legs of the sling should contain or support the load from the sides, above the center of gravity, so that the load remains under control.
- Sling shall be long enough so that the rated capacity of the sling is adequate when the angle of the legs (branches) is taken into consideration. (See Table 4 for Grade 100 Chain and Table 5 for Grade 80 Chain).

**General Usage**

It must be recognized that certain factors in the usage of chain and attachments can be abusive and lessen the load that the chain or attachments can withstand. Some examples are twisting of the chain; disfigurement; deterioration by straining, usage, weathering and corrosion; rapid application of load or jerking; applying excessive loads; sharp corner cutting, D/d, action and non-symmetrical loading effects.

**Environmental Effects**

- Excessive high or low temperatures or exposure to chemically active environments such as acid or corrosive liquids or fumes can reduce the performance of the chain and components.
- Extreme temperature will reduce the performance of alloy steel chain slings.
- Normal operating temperature is -40°F to 400°F (-40°C to 204°C).
- Reference temperature exposure chart to determine reduction of WLL due to operating at, and after exposure to, elevated temperatures (see Table 2 for Grade 80 Chain and Table 3 for Grade 100 chain).
- Chemically active environments can have detrimental affects on the performance of chain. The effects can be both visible loss of material and undetectable material degradation causing significant loss of strength.

**Special Surface Coating/Plating/Galvanizing**

- Chain should not be subjected to galvanizing, or any plating process. If it is suspected the chain has been exposed to chemically active environment, remove from service.

Temperature of Chain		Temporary Reduction of Rated Load at Elevated Temperature*	Permanent Reduction of Rated Load After Exposure to Temperature**
(F°)	(C°)		
Below 400	Below 204	None	None
400	204	10%	None
500	260	15%	None
600	316	20%	5%
700	371	30%	10%
800	427	40%	15%
900	482	50%	20%
1000	538	60%	25%
Over 1000	Over 538	OSHA 1910.184 requires all slings exposed to temperatures over 1000° F to be removed from service.	

\* Crosby does not recommend the use of Alloy Chain at temperatures above 800° F.  
\*\* When chain is used at room temperature after being heated to temperatures shown in the first column.

Temperature		Temporary Reduction of Rated Load at Elevated Temperature*	Permanent Reduction of Rated Load After Exposure to Temperature**
(F°)	(C°)		
Below 400	Below 204	None	None
400	204	15%	None
500	260	25%	5%
600	316	30%	15%
700	371	40%	20%
800	427	50%	25%
900	482	60%	30%
1000	538	70%	35%
Over 1000	Over 538	OSHA 1910.184 requires all slings exposed to temperatures over 1000 F to be removed from service.	

\* Crosby does not recommend the use of Alloy Chain at temperatures above 800° F.  
\*\* When chain is used at room temperature after being heated to temperatures shown in the first column.

**CHAIN INSPECTION  
INSPECTION AND REMOVAL FROM  
SERVICE PER ASME B30.9**

**Refer to ASME B30.9-1.9 for further information**

**Frequent Inspection**

- A visual inspection for damage shall be performed by the user or designated person each day the sling is used.
- Conditions such as those listed in ASME B30.9-1.9.4 Removal Criteria, or any other condition that may result in a hazard, shall cause the sling to be removed from service. Slings shall not be returned to service until approved by a qualified person.
- Written records are not required for frequent inspections.

**Periodic Inspection**

- A complete inspection for damage of sling shall be periodically performed by a designated person. Each link and component shall be examined individually, taking care to expose and examine all surfaces including the inner link surface. The sling shall be examined for conditions such as those listed in ASME B30.9-1.9.4 Removal Criteria, and a determination made as to whether they constitute a hazard.
- Periodic Inspection Frequency: Periodic inspection intervals shall not exceed one year. The frequency of periodic inspections should be based on:
  - Frequency of sling use.
  - Severity of service conditions.
  - Nature of lifts being made.
  - Experience gained on the service life of slings used in similar circumstances.

D/d	Reduction of Basket Hitch Rated Load
2	40%
3	30%
4	20%
5	10%
6 and above	none



Guidelines for the interval are:

1. Normal Service – yearly
  2. Severe Service – monthly to quarterly
  3. Special Service – as recommended by a qualified person
- c. Written records of the most recent periodic inspection shall be maintained, and shall include the condition of the sling.

**Removal Criteria**

An alloy sling chain shall be removed from service if conditions such as the following are present:

- a. Missing or illegible sling identification.
- b. Cracks or breaks.
- c. Excessive wear, nicks, or gouges. Minimum thickness on chain link shall not be below the values listed in Table 6.
- d. Stretched chain links or components.
- e. Bent, twisted, or deformed chain links or components
- f. Evidence of heat damage.
- g. Excessive pitting or corrosion.
- h. Lack of ability of chain or components to hinge (articulate) freely.
- i. Weld spatter.
- j. For hooks, removal criteria as stated in ASME B30.10.
- k. Other conditions, including visible damage, that cause doubt as to the continued use of the sling.

**Repair**

- a. Slings shall be repaired only by the sling manufacturer or a qualified person.
- b. A repaired sling shall be marked to identify the repairing agency per ASME B30.9 Section 9-1.7.
- c. Chain and components used for sling repair shall comply with

- d. the provisions of ASME B30.9.
- d. Repair of hooks shall comply with ASME B30.10.
- e. Cracked, broken or bent chain links or components other than hooks shall not be repaired; they shall be replaced.
- f. Mechanical coupling links shall not be used within the body of an alloy chain sling to connect two pieces of chain.
- g. Modifications or alterations to the sling or components shall be considered as repairs and shall conform to all other provisions of ASME B30.9.
- h. All repairs shall comply with the proof test requirements of ASME B30.9 Section 9-1.6.

Nominal Chain Size		Minimum Thickness	
(in)	(mm)	(in)	(mm)
7/32	5.5	0.189	4.80
9/32	7	0.239	6.07
5/16	8	0.273	6.93
3/8	10	0.342	8.69
1/2	13	0.443	11.26
5/8	16	0.546	13.87
3/4	20	0.687	17.45
7/8	22	0.750	19.05
1	26	0.887	22.53
1-1/4	32	1.091	27.71

Refer to ASME B30.9

**Table 4**  
**Grade 100 (Spectrum 10®) Alloy Chain Working Load Limit – 4 to 1 Design Factor**

Spectrum 10® Alloy Chain Size		90°	60°	45°	30°	60°	45°	30°
(in)	(mm)	Single Leg	Double Leg / Single Basket		Triple and Quad Leg / Double Basket			
—	6	3200	5500	4500	3200	8300	6800	4800
1/4 (9/32)	7	4300	7400	6100	4300	11200	9100	6400
5/16	8	5700	9900	8100	5700	14800	12100	8500
3/8	10	8800	15200	12400	8800	22900	18700	13200
1/2	13	15000	26000	21200	15000	39000	31800	22500
5/8	16	22600	39100	32000	22600	58700	47900	33900
3/4	20	35300	61100	49900	35300	91700	74900	52950
7/8	22	42700	74000	60400	42700	110900	90600	64000
1	26	59700	103400	84400	59700	155100	12600	89550
1-1/4	32	90400	156600	127800	90400	234900	191700	135600

\* For choker applications, the Working Load Limit must be reduced by 20%. The Crosby A-1338 cradle grab hook and S1311N chain shortener link do not require any reduction of the Working Load Limit. The design factor of 4 to 1 on Spectrum® 10 Alloy Chain agrees with the design factor used by the International Standards Organization (I.S.O.) and ANSI B30.9 and is the preferred set of Working Load Limit values to be used. Do not use sling angles of less than 30°.

**Table 5**  
**Grade 80 (Spectrum 8®) Alloy Chain Working Load Limit – 4 to 1 Design Factor**

Spectrum 8® Alloy Chain Size		90°	60°	45°	30°	60°	45°	30°
(in)	(mm)	Single Leg	Double Leg / Single Basket		Triple and Quad Leg / Double Basket			
—	6	2500	3600	3000	2500	6500	5300	3750
1/4 (9/32)	7	3500	6100	4900	3500	9100	7400	5200
5/16	8	4500	7800	6400	4500	11700	9500	6800
3/8	10	7100	12300	10000	7100	18400	15100	10600
1/2	13	12000	20800	17000	12000	31200	25500	18000
5/8	16	18100	31300	25600	18100	47000	38400	27100
3/4	20	28300	49000	40000	28300	73500	60000	42400
7/8	22	34200	59200	48400	34200	88900	72500	51300
1	26	47700	82600	67400	47700	123900	101200	71500
1-1/4	32	72300	125200	102200	72300	187800	153400	108400

\* For choker applications, the Working Load Limit must be reduced by 20%. The Crosby A-1338 cradle grab hook and S1311N chain shortener link do not require any reduction of the Working Load Limit. The design factor of 4 to 1 on Spectrum® 8 Alloy Chain agrees with the design factor used by the International Standards Organization (I.S.O.) and ASME B30.9 and is the preferred set of Working Load Limit values to be used. Do not use sling angles of less than 30°.

# CROSBY ELIMINATOR®

## WARNING & APPLICATION INSTRUCTIONS

### ⚠ WARNING

- Failure to read, understand, and follow these instructions may cause death or serious injury.
- Read and understand these instructions before using the Crosby ELIMINATOR®.
- Incorrectly rigging or terminating exerts additional force or loading, which the Crosby ELIMINATOR® is not designed to accommodate.

### Crosby ELIMINATOR® Definitions

The Crosby ELIMINATOR® consists of a bail, hinge bolt, latch pin, and lower body with cradle slot/slots.

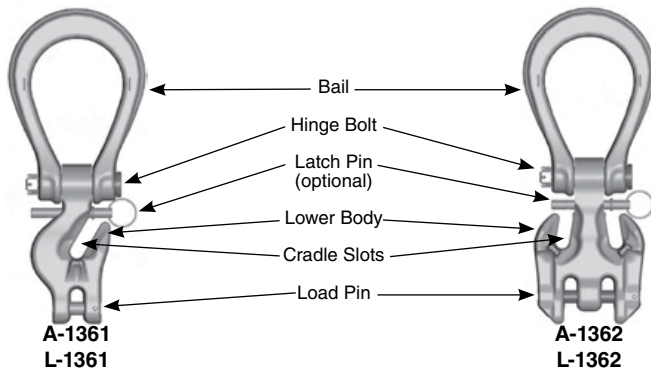

The Crosby ELIMINATOR® incorporates markings forged into the product which address a QUIC-CHECK® feature:

**Deformation Indicators** – Two strategically placed marks on each leg of the bail, which allows for a QUIC-CHECK® measurement to determine if the bail opening has changed, thus indicating abuse or overload. To check, use a measuring device (i.e. tape measure) to measure the distance between the marks. The marks should align to either an inch or half-inch increment on the measuring device. If the measurement does not meet criteria, the Crosby ELIMINATOR® bail should be inspected further for possible damage.

### Important Safety Information Read and Follow

- A visual periodic inspection for cracks, nicks wear, gouges and deformation as part of a comprehensive documented inspection program, should be conducted by trained personnel in compliance with ANSI B30.9.
- Remove from service any Crosby ELIMINATOR® components with a crack, nick, or gouge. The bail and body of a Crosby ELIMINATOR® with nick or gouge shall be repaired by a qualified person. The qualified person shall repair by grinding longitudinally following the contour of the forging, provided that the reduced dimension is within the limits shown in (Fig. A).

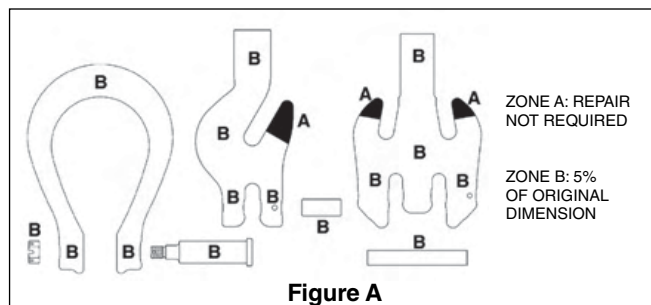

Figure A

- Never repair, alter, rework, or reshape a Crosby ELIMINATOR® by welding, heating, burning, or bending.
- Crosby ELIMINATOR® combination master link and chain shortener shall not be used in a manner other than that for which it is intended.
- The sling may be shortened by use of the cradle slot/slots (see Fig. C).
- In shortening applications, the Crosby ELIMINATOR® can be used without any reduction to the Working Load Limit.
- Never terminate (i.e. place a load bearing chain sling hook), or reeve load bearing chain through Crosby ELIMINATOR® bail. (see Fig. B).
- Never exceed the rated capacity shown on sling's identification tag.
- Attach lifting device to ensure free fit of Crosby ELIMINATOR® bail (see Fig. D). Never allow lifting device to apply forces on side of bail (see Fig. E), as this condition will damage and reduce the capacity of the Crosby ELIMINATOR®.
- The Crosby ELIMINATOR® is intended for tension or pull. Side loading must be avoided, as it exerts additional force or loading which the product is not designed to accommodate. (see Fig. F).

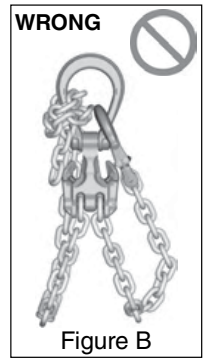

Figure B



Figure C

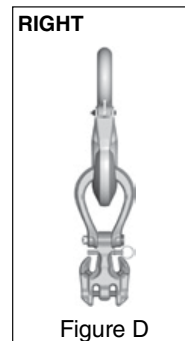

Figure D

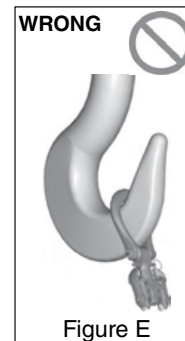

Figure E



Figure F

- Never use a Crosby ELIMINATOR® where the bail shows signs of deformation or overloading (see Table 1).
- Read and understand the other sections of the ALLOY STEEL CHAIN SLINGS Warning, Selection, Use & Maintenance Information.

Chain Size		Frame I.D. Code	Inside Length (in)	Inside Width (in)	Jaw Width (in)	QUIC-CHECK® Dim (in)
(in)	(mm)					
1/4 - 5/16	7 - 8	2	3.88	3.00	.94	3.50
3/8	10	3	4.81	3.50	1.13	4.00
1/2	13	4	6.00	4.13	1.31	5.00
5/8	16	5	6.88	4.75	1.63	6.00

- A Crosby ELIMINATOR® under load shall be allowed to self-align itself about the hinge pin.
- The use of a latch may be mandatory by regulations or safety codes; e.g. OSHA, MSHA, ASME B30.10 and B30.9.
- If Crosby latch pin is present, it should fit and function properly, and show no signs of distortion or bending.
- Always make sure the chain is seated in the cradle slot, and the cradle supports the load. The latch pin must never support the load.
- Latch pins are not intended to be an anti-fouling device.
- Use only genuine Crosby repair and latch pins parts.

### A-1361 Single Leg Crosby ELIMINATOR®

- The A-1361 single leg Crosby ELIMINATOR® is designed to support a single leg vertical load. The cradle slot may be used to make a loop in the leg (see Fig. G). However, the Working Load Limit is still limited to the single leg values shown in Table 4 (Grade 100) and Table 5 (Grade 80).
- To produce a single basket hitch and achieve the full Working Load Limit, use only one length of chain with both ends terminated into the load pins of two A-1361 single leg Crosby ELIMINATOR® fittings (see Fig. H). Basket may be shortened with cradle slot.
- Never exceed the single leg Working Load Limit shown in Table 4 (Grade 100) and Table 5 (Grade 80) for an individual A-1361 Crosby ELIMINATOR® fitting.



### A-1362 Double Leg Crosby ELIMINATOR®

- The A-1362 double leg Crosby ELIMINATOR® is designed to support symmetrically loaded double leg slings at 60, 45, and 30 degree horizontal angles. The cradle slots may be used to make loops in the legs (see Fig. J). However, the Working Load Limit is limited to the double leg values shown in Table 4 (Grade 100) and Table 5 (Grade 80).
- To produce a single basket hitch, and achieve the full Working Load Limit, use only one length of chain with both ends terminated into the load pin (see Fig. K). Basket may be shortened with the cradle slot or slots.
- To produce a double basket hitch and achieve the full Working Load Limit, two A-1362 double leg Crosby ELIMINATOR® fittings must be used, with both being terminated at their load pin (see Fig. L).
- Never exceed the double leg / single basket Working Load Limit on an individual A-1362 Crosby ELIMINATOR® fitting.

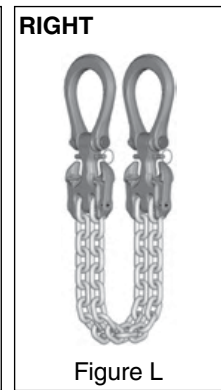
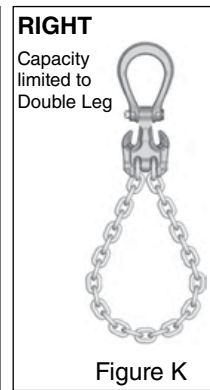

# Lebus® LOAD BINDER

## WARNINGS & APPLICATION INSTRUCTIONS

### WARNING

- Failure to use this load binder properly may result in serious injury or even death to you or others.
- Do not operate load binder while standing on the load.
- Move handle with caution. It may whip – Keep body clear.
- Keep yourself out of the path of the moving handle and any loose chain laying on the handle.
- You must be familiar with state and federal regulations regarding size and number of chain systems required for securing loads on trucks.
- Always consider the safety of nearby workers as well as yourself when using load binder.
- While under tension, load binder must not bear against an object, as this will cause side load.
- Do not throw these instructions away. Keep them close at hand and share them with any others who use this load binder.
- Do not use handle extender – see instructions.
- Do not attempt to close or open the binder with more than one person.

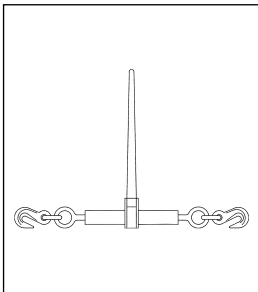

Ratchet Type

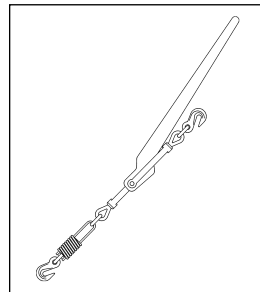

Lever Snubbing Type

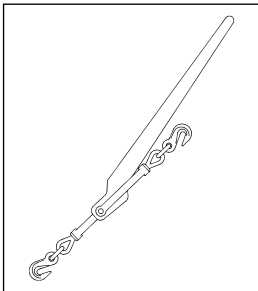

Lever Type

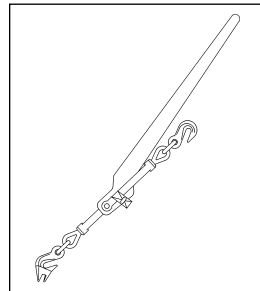

Lever Walking Type

### Mechanical Advantage

Lever Type Binder = 25 : 1

Ratchet Type Binder = 50 : 1

**Example:** 100 pounds of effort applied to the binder results in the following force on the binder.

### Lever Type:

100 lb x 25 = 2500 lb of force

### Ratchet Type:

100 lb x 50 = 5000 lb of force

## Instructions – Lever Type Load Binders

- Hook load binder to chain so you can operate it while standing on the ground. Position load binder so its handle can be pulled downward to tighten chain (see photo). **Be aware of ice, snow, rain, oil, etc. that can affect your footing. Make certain your footing is secure.**
- The Crosby Group LLC specifically recommends AGAINST the use of a handle extender (cheater pipe). If sufficient leverage cannot be obtained using the lever type load binder by itself, a ratchet type binder should be used.
- If the above recommendation is disregarded and a cheater pipe is used, it must closely fit the handle and must slide down the handle until the handle projections are contacted. The pipe should be secured to the handle, for example, by a pin, so that the pipe cannot fly off the handle if you lose control and let go. The increased leverage, by using a cheater pipe, can cause deformation and failure of the chain and load binder.
- During and after tightening chain, check load binder handle position. **Be sure** it is in the locked position and that its bottom side touches the chain link.
- Chain tension may decrease due to load shifting during transport. To be sure the load binder remains in proper position: Secure handle to chain by wrapping the loose end of chain around the handle and the tight chain, or tie handle to chain with soft wire.
- When releasing load binder, remember there is a great deal of energy in the stretched chain. This will cause the load binder handle to move very quickly with great force when it is unlatched. **Move handle with caution. It may whip – Keep body clear.**
- **Never use a cheater pipe or handle extender to release handle.** Use a steel bar and pry under the handle and stay out of the path of handle as it moves upward.
- If you release the handle by hand, use an open hand under the handle and push upward. **Do not close your hand around the handle. Always keep yourself out of the path of the moving handle.**



Chain & Accessories

## Instructions - Ratchet Load Binders

- Position ratchet binder so it can be operated from the ground.
- **Make sure your footing is secure.**

## Maintenance of All Load Binders

- Routinely check load binders for wear, bending, cracks, nicks, or gouges. **If visual wear bending or cracks are present - Do not use load binder.**
- Routinely lubricate pivot and swivel points of Lever Binders, and pawl part and screw threads of Ratchet Binders to extend product life and reduce friction wear.



Crosby® SHUR-LOC® HOOKS

WARNING & APPLICATION INSTRUCTIONS



Important Safety Information - Read and Follow

- A visual periodic inspection for cracks, nicks, wear, gouges and deformation as part of a comprehensive documented inspection program, should be conducted by trained personnel in compliance with the schedule in ASME B30.10.
  - For hooks used in frequent load cycles, pulsating loads, or severe duty as defined by ASME B30.10, the hook and threads should be periodically inspected by Magnetic Particle or Dye Penetrant. (Note: Some disassembly may be required.)
  - Never use a hook whose throat opening has been increased 5%, not to exceed 1/4"(6mm) or shows any visible apparent bend or twist from the plane of the unbent hook, or is in any other way distorted or bent. **NOTE: A latch will not work properly on a hook with a bent or worn tip.**
  - Never use a hook that is worn beyond the limits shown in Figure 1.
  - Remove from service any hook with a crack, nick, or gouge. Hooks with a nick, or gouge shall be repaired by grinding lengthwise, following the contour of the hook, provided that the reduced dimension is within the limits shown in Figure 1. Contact Crosby Engineering to evaluate any crack.
  - Never repair, alter, rework, or reshape a hook by welding, heating, burning, or bending.
  - Never side load, back load or tip load a hook. Side loading, back loading and tip loading are conditions that damage and reduce the capacity of the hook. (See Figure 2)
  - S-1326A can be used for limited rotations under load (infrequent, noncontinuous).
  - Efficiency of synthetic sling material may be reduced when used in eye or bowl of hook.
  - Always make sure the hook supports the load. (See Figure 3).
- Do not use hook tip for lifting (See Figure 4).

WARNING

- Loads may disengage from hook if proper procedures are not followed.
- A falling load may cause serious injury or death.
- Positive locking latch will unlock when trigger is depressed. Never use hook unless hook and latch are fully closed and locked.
- Keep body parts clear of pinch point between hook tip and hook latch when closing.
- Keep hand(s) from between throat of hook and sling or other device.
- Do not use hook tip for lifting.
- Do not use hook handle for lifting.
- Do not rig the finger pull open, place objects in the finger pull area, or in any way inhibit complete and full operation of the finger pull mechanism.
- Shank threads may corrode and/or strip and drop the load.
- Remove securement nut to inspect threads for corrosion or to replace S-1326A bearing washers (2) and or S-13326 thrust bearing.
- Never apply more force than the hook's assigned Working Load Limit (WLL) rating.
- See OSHA Rule 1926.1431(g) and 1926.1501(g) for personnel hoisting by cranes or derricks. A Crosby 1318A, 1326A, 13326, 1316A, or 1317A hook may be used for lifting personnel.
- Use only genuine Crosby parts as replacements.
- Read and understand these instructions before using hook.

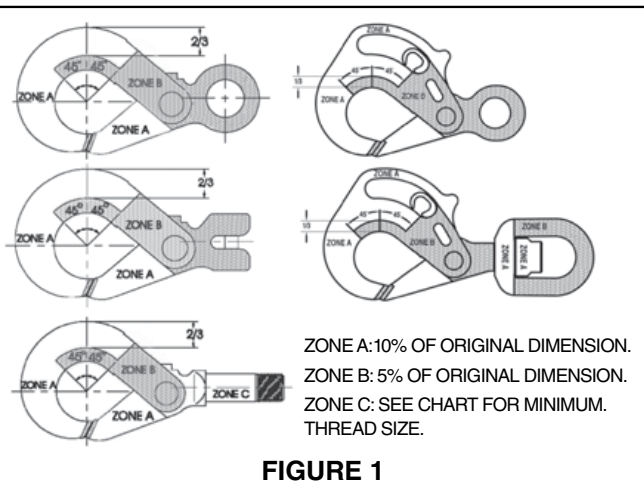

FIGURE 1

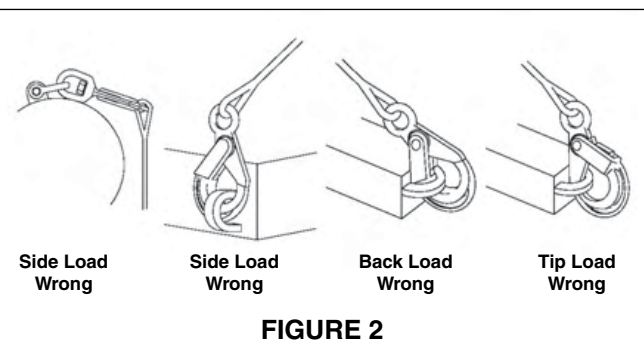
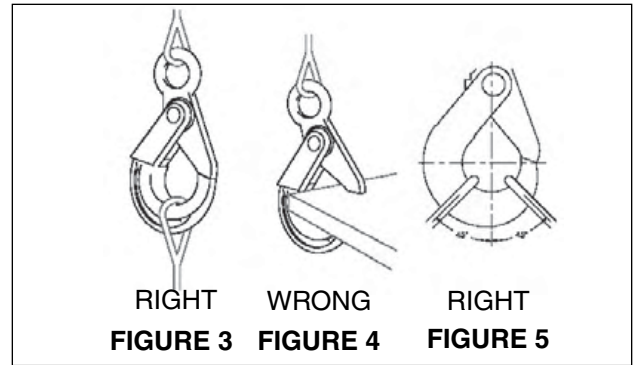

FIGURE 2

- When placing two (2) sling legs in hook, make sure the angle from vertical to the leg nearest the hook tip is not greater than 45 degrees, and the included angle between the legs does not exceed 90 degrees\* (See Figure 5).

- See ASME B30.10 "Hooks" for additional information.

\* For two legged slings with angles greater than 90°, use an intermediate link such as a master link or bolt type shackle to collect the legs of the slings. The intermediate link can then be placed over the hook to provide an in-line load on the hook. This approach must also be used when using slings with three or more legs.



### Important Basic Machining and Thread Information: Read and Follow

- Wrong thread and/or shank size can cause stripping and loss of load.
- The maximum diameter is the largest diameter, after cleanup, that could be expected after allowing for straightness, pits, etc.
- All threads must be Class 2 or better.
- The minimum thread length engaged in the nut should not be less than one (1) thread diameter.
- Hook shanks are not intended to be swaged on wire rope or rod.
- Hook shanks are not intended to be drilled (length of shank) and internally threaded.
- Crosby cannot assume responsibility for, (A) the quality of machining, (B) the type of application, or (C) the means of attachment to the power source or load.
- Consult the Crosby Hook Identification & Working Load Limit Chart (See below) for the minimum thread size for assigned Working Load Limits (WLL). †
- Remove from service any Hook which has threads corroded more than 20% of the nut engaged length.

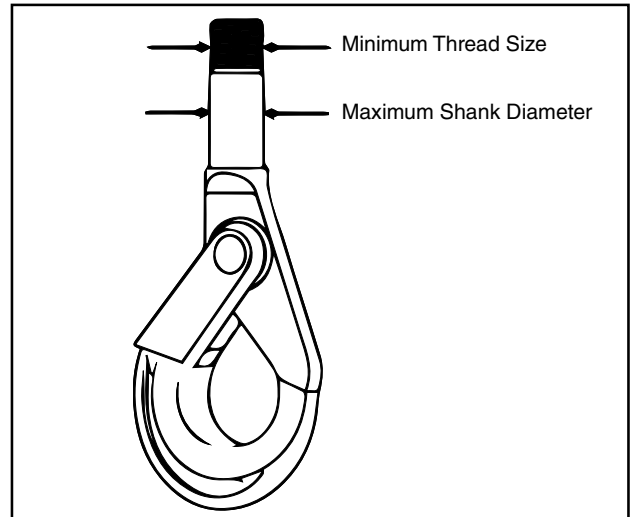

Chain & Accessories

## Crosby® Hook Identification & Working Load Limit Chart †

S-1316A & S-1317A Only Grade 100 Chain			S-1318A, S-1326A					S-1318A Only † †		
Chain Size		Working Load Limit (lb)** 4:1	Grade 100 Chain			Wire Rope XXIP Mechanical Splice		Maximum Shank Diameter		Minimum Thread Size (in)
(in)	(mm)		(in)	(mm)	Working Load Limit (lb)** 4:1	Wire Rope Size (in)	Working Load Limit (lb)* 5:1	(in)	(mm)	
—	6	3200	—	6	3200	5/16	2200	.72	18	5/8 - 11 UNC
1/4	7	4300	1/4	7 - 8	4300	7/16	4200	.94	24	5/8 - 11 UNC
5/16	8	5700	5/16	8	5700	7/16	4200	.94	24	3/4 - 10 UNC
3/8	10	8800	3/8	10	8800	1/2	5600	1.06	27	3/4 - 10 UNC
1/2	13	15000	1/2	13	15000	5/8	8600	1.19	30	1-1/8 - 7 UNC
5/8	16	22600	5/8	16	22600	7/8	16600	1.38	35	1-3/8 - 6 UNC
3/4	18/20	35300	3/4	18-20	35300	1	22000	—	—	—
7/8	22	42700	7/8	22	42700	1-1/8	26500	—	—	—
1	26	59700	1	26	59700	1-1/4	32500	—	—	—

\* Ultimate Load is 5 times the Working Load Limit based on XXIP Wire Rope.

\*\* Ultimate Load is 4 times the Working Load Limit based on Grade 100 Chain.

+ Working Load Limit - The maximum mass of force which the product is authorized to support in general service when the pull is applied in-line, unless noted otherwise, with respect to the centerline of the product. This term is used interchangeably with the following terms: 1. WLL, 2. Rated Load Value, 3. SWL, 4. Safe Working Load, 5. Resultant Safe Working Load.

**Lebus® L-180 WINCHLINE TAIL CHAIN**  
**WARNING & APPLICATION INSTRUCTIONS**



L-180

<b>WARNING</b>	
<ul style="list-style-type: none"> <li>• Loads may disengage from winchline tail chain if proper procedures are not followed.</li> <li>• A falling load or disengaged winchline tail chain may cause serious injury or death.</li> <li>• Inspect winchline tail chain for damage before each use.</li> <li>• Wire rope should not be terminated to tail chain by the use of a knot.</li> <li>• Do not attach slings or other devices in hook for overhead lifting – see operating practices.</li> </ul>	

**Important Safety Information – Read & Follow**

- Only winchline tail chains made from alloy chain, Grade 80 or Grade 100, should be used for overhead lifting applications.
- Working Load Limit (WLL) is the maximum load in pounds which should ever be applied to winchline tail chain.
- The Working Load Limit or Design Factor may be affected by wear, misuse, overloading, corrosion, deformation, intentional alterations, sharp corner cutting action and other use conditions.
- Never repair, alter, rework, or reshape a hook or chain by welding, heating, burning or bending.
- Recommended for IPS or XIP (EIP), RRL, FC or IWRC wire rope.
- Shock loading and extraordinary conditions must be taken into account when selecting winchline tail chains.

**CAUSE FOR REMOVAL FROM SERVICE**

A winchline tail chain shall be removed from service if any of the following are visible on chain or hook:

- Wear, nicks, cracks, breaks, gouges, stretch, bend, weld splatter and discoloration from excessive temperature. Minimum thickness on chain link shall not be below the values listed on Table 1.
- Chain links and hook that do not hinge freely to adjacent links.
- Excessive pitting or corrosion on chain, hook or termination fitting.
- Makeshift fasteners, hooks, or links formed from bolts, rods, etc.

L-180 Stock No.	Wire Rope Diameter (in)	Nominal Chain Size	
		(in)	(mm)
1091482	1/2 - 5/8	5/8	16
1091511	3/4 - 7/8	7/8	22
1091516	1-1-1/8	1	26
1091525	1-1-1/8	1	26
1091532	1-1/4	1-1/4	32

- Mechanical coupling links in the body of the chain.
- Other damage that would cause a doubt as to the strength of the chain.
- Winchline tail chain should not be subjected to galvanizing or any plating process. If it is suspected the chain has been exposed to chemically active environment, remove from service.
- Termination end attachments that are cracked, deformed, or worn.
- For wire rope inspection procedures and removal from service criteria refer to manufacturer's recommendations.

**OPERATING PRACTICES**

- Know the winch lifting/pulling systems capacity rating.
- Know the applied load on tail chain. In dragging applications, the applied load may be greater or less than its weight due to friction.
- During lifting/dragging with or without the load, personnel should be alert for possible snagging.
- WORKING LOAD LIMIT (WLL) is the maximum load in pounds which should ever be applied to winchline tail chain when the chain is new or in "as-new" condition, and when the load is uniformly applied in direct tension to a straight length of chain.

Wire Rope Diameter (in)	L-180 Stock No.	Working Load Limit 3.5 to 1 Design Factor (lb)
1/2 - 5/8	1091482	13000
3/4 - 7/8	1091511	34200
1 - 1-1/8	1091516	47700
1 - 1-1/8	1091525	47700
1-1/4	1091532	73200

5/16 thru 5/8 made from Grade 40 High Test carbon steel.  
 3/4 thru 1-1/4 made from Grade 80 or Grade 100 alloy steel. Only alloy tail chain should be used for overhead lifting applications.

- Wire rope termination efficiency and tail chain Working Load Limit (WLL) must be considered when selecting termination fitting and tail chain.
- Efficiency of wire rope end termination is based on the catalog breaking strength of wire rope.

Typical Termination Method & Efficiency	
Termination	Efficiency
S-409 Swage Button	80%

- The winchline tail chain hook is designed to fit the winchline diameter when hooked or connected back to winchline (See Figure 1).
- When used to pull or drag a load, the winchline tail chain may be wrapped around the load and the hook connected to the winchline. Also, when used to pull or drag a load over the tail board roller, the tail chain hook may be attached directly to the load at a connection point authorized by a competent rigger (See Figure 5). In either case, a visual verification of proper hook engagement is required during the entire operation.
- When used in overhead lifting applications, the winchline tail chain may be wrapped around the load and the hook connected to the winchline (See Figure 1). Used in this manner, this connection provides the same load control advantages and limitations as a single leg wire rope sling basket or choker hitch. The winchline tail chain should

contain and support the load from the sides, above center of gravity, so load remains under control. A visual verification of proper hook engagement is required during the entire operation.

- The tail chain hook has no provision for a latch; therefore, The Crosby Group, LLC. specifically recommends AGAINST placing the load, slings or other devices directly into the tail chain hook for the purpose of overhead lifting. A latch may be mandatory by regulations or safety codes: e.g. OSHA, MSHA, ASME B30, insurance, etc. (See Figure 2).

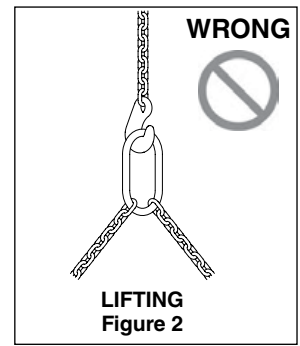
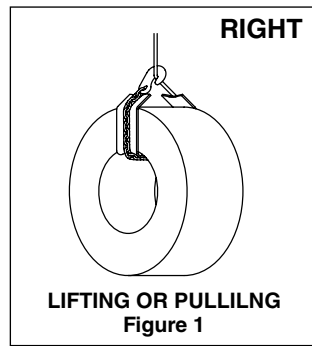

**If the above Crosby recommendation is disregarded and slings or other devices are placed directly into the tail chain hook, as a minimum ensure:**

- Personnel shall stand clear of the suspended load.
- Visual verification of proper hook engagement is required in all cases.
- The sling or device should be centered in the base (bowl/saddle) of the hook.
- The user must assure connection to the hook is secure throughout the movement of the load.
- A designated competent rigger must verify that all appropriate rigging practices are followed for attachment and control of load.
- The winchline and tail chain links should always be protected from being damaged by sharp corners (See Figure 3).
- Chain links should not be twisted or kinked.
- Winchline or tail chain should not be pulled from under loads if the load is resting on winchline or tail chain.
- Winchline or tail chain that appears to be damaged should not be used unless inspected and accepted by a designated person.
- Never side load, back load, or tip load hook (See Figure 4).
- All portions of the human body should be kept from between the winchline / tail chain and load.
- Personnel shall stand clear of the suspended load.
- Shock loading should be avoided.
- Extreme temperature will reduce the performance of winchline tailchain.
- Normal operating temperature is -40°F to 400°F (-40°C to 204°C).

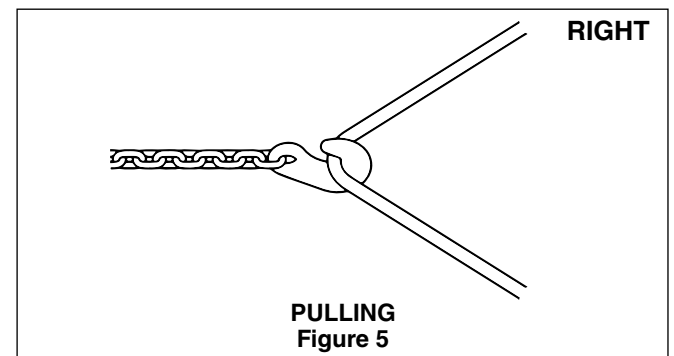
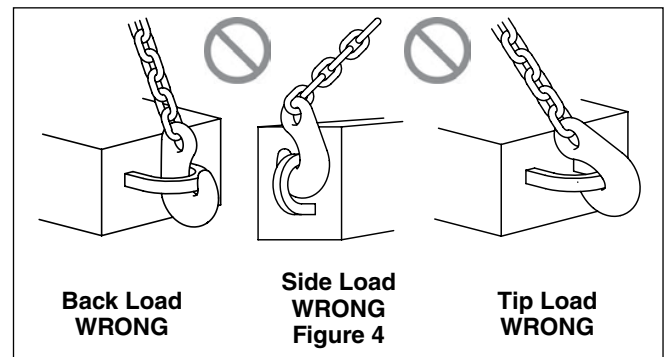
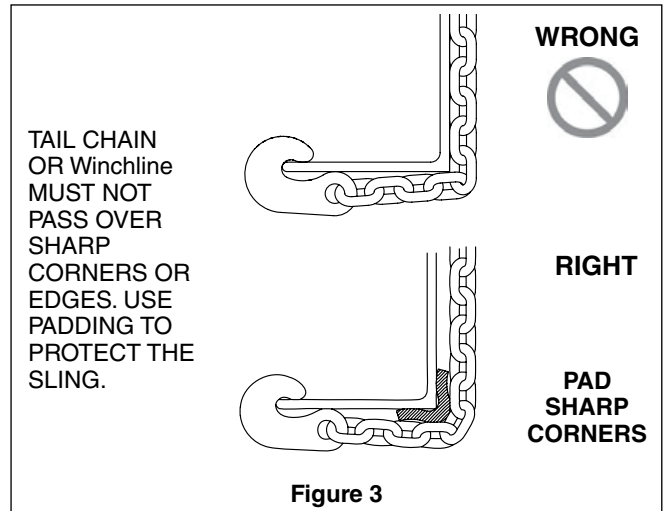



# Alloy Fittings Application and Information

## HOW TO ASSEMBLE AN S-1325 COUPLER LINK ONTO MASTER LINK



1. Slide Coupler Link over Engineered Flat of Master Link.



2. Rotate Coupler Link so that clevis fitting is to the outside of Master Link and attach to chain sling.

## HOW TO ASSEMBLE A CROSBY CLEVIS TYPE FITTING



1. Place chain link into clevis of chain coupler. Insert pin fully into the clevis ears.



2. Place the coupler link on its side and using a hammer, drive the locking pin into the clevis ear until it is flush with the outside surface.

## HOW TO ASSEMBLE A LOK-A-LOY® CONNECTING LINK



1. Place the locking sleeve between the assembled half link forgings.



2. Drive the pin through the assembled link ends and sleeve until the end of the pin is flush with the outside of the connecting link halves.

## HOW TO ASSEMBLE LOAD PIN IN CROSBY ELIMINATOR® FITTINGS



1. Place both chain links into clevis slots of fitting, insert pin fully into the two-leg clevis.



2. Place Eliminator assembly on a firm surface. Using a hammer, drive the locking pin into the two-leg clevis until it is flush with the top of the hole.

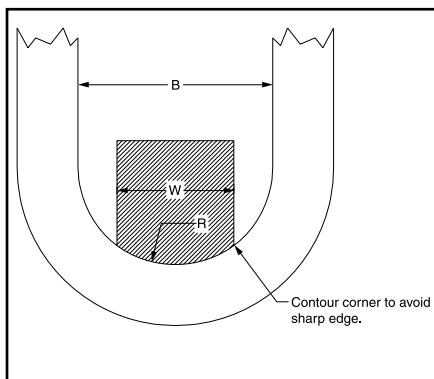
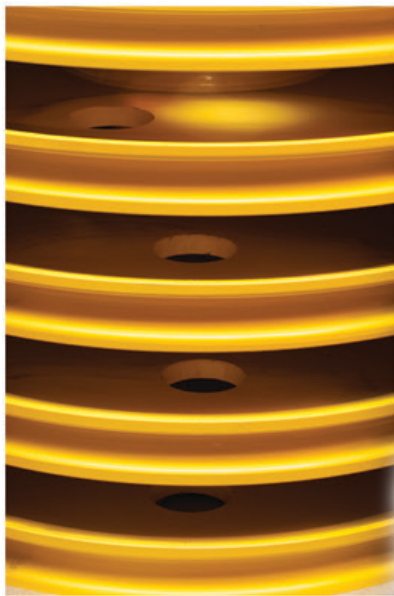

Figure 1

Crosby master links and master link assemblies are proof tested with special fixtures in accordance with ASTM A952 and EN-1677-4. The purpose of the special fixture is to prevent localized point loading during the proof test. Point loading at the proof test load may result in permanent deformation. ASTM A952 allows for a maximum proof test fixture width (W) of 60% of the inside width (B) of the master link. EN 1677-4 allows for a maximum proof test fixture width (W) of 70% of the inside width (B) of the master link. The radius of the fixture (R) is one-half of inside width of the master link. A sketch showing an example of the special fixture is shown in Figure 1. Note that the corner of the fixture should be contoured so that a sharp edge does not make contact with the master link during the loaded condition.

Over the years some master links and master link assemblies have changed dimensions and working load limits. Special consideration should be given to the actual inside width of the master link being tested and its correct allowable proof load value. If the correct allowable proof load value is in question, then Crosby Engineering should be consulted for the appropriate proof load value.



# McKISSICK SHEAVES

With Product Warnings and Application Information





# "There is No Equal"



The Market Leader: Yesterday Today and Tomorrow

## McKissick Sheaves

### HISTORY & EXPERIENCE

The ability to match the sheave design and manufacturing process to meet the application requirements requires experience. It also requires the ability to creatively use this experience and manufacturing resources to provide the best solution.

### THE COMPETITION

- Ask:** What is their history and experience?
- Ask:** What processes do they have available to draw upon?
- Ask:** What technical experience do they have available to provide technical solutions to technical demands?



McKissick has provided sheaves to energy and lifting industries since the early 1900's. Since McKissick became part of Crosby in the mid 1900's there has been a continuous history of product and process development. Crosby invented the roll forged sheave in 1978 and continues to be a leader today in sheave design and manufacturing process.

### DELIVERY & ACCESSIBILITY

Many energy and lifting sheave applications require short delivery times and delivery to locations around the world. Response times require flexible manufacturing resources. Access around the world requires not only logistics experience and capabilities, but also requires manufacturing resources strategically located around the world.

### THE COMPETITION

- Ask:** How do they support short deliveries?
- Ask:** What is their experience providing worldwide delivery?
- Ask:** What resources do they have in key areas of the world?



Crosby-McKissick stocks key raw materials and has an extensive bank of tooling and sufficient manufacturing capacity to support short deliveries. Crosby has McKissick block and sheave centers that serve their local markets in Tulsa, Oklahoma (USA); Putte, Belgium; Singapore; and Hangzhou, China.

### FLEXIBILITY OF DESIGN

Matching the best solution to the application requires the ability to fabricate sheaves by a number of processes:

- 1) Heavy Duty – Roll forged sheaves are hot forged with no splitting stresses at base for sheaves up to 78".
- 2) Heavy Duty – Closed die forged sheaves with machined Wireline groove for sheaves up to 16".
- 3) Extreme Duty – Roll forged sheaves with welded dome reinforcement employ the latest welding technology with no shape cross brace stress concentration areas.
- 4) Heavy Duty fabricated sheaves – With welded rings and reinforced webs utilizing the latest welding technology.
- 5) The ability to provide sheave grooves with 30, 35 and 45 degree profiles as well as other special profile
- 6) The ability to provide bearings to match application: Plain bore, bronze bushed, roller bearings, tapered roller bearings and full complement bearings.
- 7) Heat treatment of Wireline groove to provide wear resistance.

### THE COMPETITION

- Ask:** How do they achieve the performance required with a split or cast sheave?
- Ask:** How do they resolve the welding stresses induced when you fabricate the sheave?
- Ask:** What sheave groove profile do they provide on a regular basis?
- Ask:** Do they have technical expertise to recommend proper sheave bearings?
- Ask:** How do they provide for proper Wireline groove life?



McKissick offers roll forged sheaves that provide an upset metal flow without creating a stress zone at the splitting point. The dome-reinforced sheave design provides for a continuous weld in a circular pattern. McKissick produces sheaves in 30, 35, and 45 degree profiles, and can provide special profiles as required. Extensive experience underwater and in harsh and demanding environments gives McKissick the needed experience in selecting sheaves for all applications. From material selection to hardening of the groove, McKissick sheaves provide the needed wire-line life.

### SPECIFICATIONS

Many energy and lifting sheaves must meet standards. These standards include API, ABS, DIN, DNV and ASME. Demanding specifications for sheaves used in demanding applications also include strength, fatigue, impact and non-destructive testing.

### THE COMPETITION

- Ask:** Do they understand and have experience in meeting the industry standards such as API, ABS, DIN, DNV and ASME?
- Ask:** Do they have a history of gaining required approvals?
- Ask:** Are they licensed to manufacture sheaves to API 8C?



Crosby McKissick has achieved API Q1, and TS29001 Status, and is licensed to manufacture sheaves to API 8C. Sheaves are frequently provided to API, DNV and ABS requirements.

### TECHNICAL SUPPORT & TRAINING

The selection, use, inspection and maintenance of sheaves requires technical support. This technical support includes engineering services, training support and the ability to meet the various industry requirements around the world.

### THE COMPETITION

- Ask:** What technical support do they provide?
- Ask:** Where is this support provided from?
- Ask:** What training is available to support the selection, use, inspection and maintenance of sheaves?



Crosby has technical and operational support available from each of our McKissick Block and Sheave Centers around the world. Crosby provides extensive training through our one day Block and Sheave Clinics and our two-day Heavy Lift Seminars. Industry-specific training is also provided.

**Remember: "When buying Crosby, you're buying more than product, you're buying Quality."**

**McKissick® Roll-Forged Heavy Duty Sheaves** are made by upsetting and forming the groove and flange walls in multiple steps, eliminating the need to split and weaken the groove. This exclusive forging process adds extra strength to the critical groove section.

**McKissick Domed Reinforced Extreme Duty Roll Forged Sheaves** are welded in a circular pattern thus eliminating the higher stresses created by welding ribs or other forms of stiffeners.

**McKissick Heavy Duty Sheaves** are available with machined groove rings or machine forged rings utilized for the rim or hub.

**McKissick Heavy Duty Closed-Die Forged Sheaves** offer the performance of closed-die forging with the precision machining capabilities of CNC machinery.

**McKissick Normal Duty Malleable Cast Sheaves** provide economical solutions for normal service applications.

**McKissick Sheaves** come in a variety of sizes to suit your specific applications. Crosby offers many sheaves as standard and these are shown in the pages that follow. For applications that require unique specifications, Crosby can make minor modifications to many of the sheaves listed at a reasonable charge. We can also custom design and manufacture sheaves to your exact requirements. McKissick roll forged sheaves can be furnished balanced or with lightening holes at a reasonable charge on request.

**Crosby's Hardening Technique** is a science. It provides a precise maximum hardness for wear-resistance across the wire rope contact area. The McKissick sheave groove is flame hardened to a minimum 35 Rockwell C for a 140° contact area with the wire rope (upon special request the McKissick sheave groove can be flame hardened to a minimum 50 Rockwell C for a 150° contact area with the wire rope). The solid steel plate provides the ideal surface for flame hardening and a closer tolerance fit to the wire rope to reduce fatigue and wear.

**The McKissick Hub** is stepped to eliminate stress failure in the weld, common in traditional hub designs. The hub is pressed into place with complete metal-to-metal contact. This helps ensure an accurate alignment to the hub's axis so there is no wobble or lopping of the rotating sheave. The precision aligned hub / sheave wheel combination adds to the bearing life and keeps the sheave on the job longer.

## McKISSICK® STANDARD BEARINGS



(B) Bronze Bushing



(R) Roller Bearings



(W) Roller Bearing  
with Thrust Washers



(C) Full Complement Cylindrical  
Roller Bearing



(T) Tapered Roller  
Bearing

## McKISSICK® Wireline GROOVE PROFILES

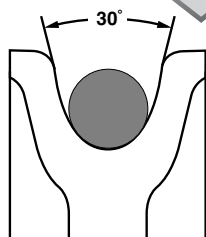

API STYLE  
30 degrees

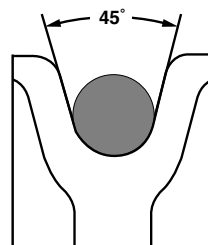

EUROPEAN STYLE  
45 degrees

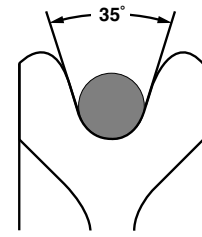

AISE STYLE  
35 degrees

*Custom sheaves are available. See page 287 for ordering details.*



# DO NOT BE FOOLED

## The Elements of a Superior Sheave

Every McKissick® Roll-Forged sheave starts as a single piece of AISI C-1035 carbon steel plate. Utilizing a time proven proprietary roll forging process that adds extra strength to the critical groove section, the sheave is formed from a precision flame cut blank. The hub is then pressed into place with complete metal-to-metal contact and secured with a deep penetrating weld to ensure proper fit and longer life. Before the McKissick® name is added, each sheave is thoroughly inspected to meet applicable industry and Crosby® quality standards.

**McKissick® Roll-Forged sheaves contain the following critical standard features required to meet your demanding applications:**

**1** Smooth radius at the rim provides superior transition from outside diameter to groove - eliminating sharp corners that can damage rope

- Cold formed split steel sheaves may contain a sharp transition radius at rim of sheave



**2** Size for size, McKissick® Roll-Forged sheaves have a thicker section under the tread of the Wireline groove - providing more substantial support of the Wireline

- Cold formed split steel sheaves are limited to a thinner section thickness under the groove, reducing sheave life in heavy service conditions
- Thinner sections produce a sharp corner under the tread, resulting in potential stress risers

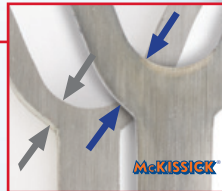

**3** Thicker web on sheave provides required stiffness to support a stronger sheave that contains thicker flange sections

- The thinner web on cold formed split steel sheaves, inherent to the process, does not support thicker flange section
- The sharp, pointed cutter used in forming the groove during the cold formed split steel process may produce a concealed crack in the bottom of the groove

	McKissick®	Cold Formed Split Steel
Smooth Radius Edge - Better fit, less wear on rope	4	
Thicker Fleet Section - Better support, stronger sheave groove	4	
Deep Penetrating Weld at Hub - Longer life	4	
Flame Hardened Groove - Higher Rockwell C rating	35Rc	14Rc
Roll Forging Process - Provides superior grain flow	4	



**There is no sheave like a McKissick® Roll-Forged Sheave**

# ...into thinking all sheaves produce the same results.

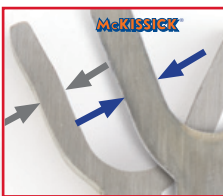

**4** Heavier flange sections - provide a much stronger wire rope groove and maintain proper consistent groove angles, ensuring long term Wireline performance

- Cold formed split steel sheaves tend to have flange sections that are thinner as well as variations in thickness on the same sheave, resulting in less than desired performance during critical applications
- Cold formed split steel sheaves are limited to a maximum flange thickness of 50% of web section

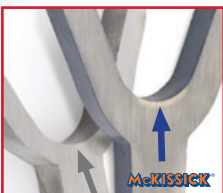

**5** Minimum 35Rc for higher hardness in the bottom of the groove - results in less wear to the sheave, thus extending life of Wireline

- Unless requested at time of order, cold formed split steel sheaves have a much lower hardness rating (approx. 14Rc)
- The standard material used in cold formed split steel process may not allow higher hardness in groove

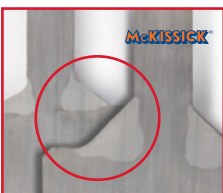

**6** Precision alignment of hub with blank, then finished with a deep penetrating weld - ensuring proper fit, longer life and confidence during the most extreme of applications

**Cold Formed Split Steel Sheave**

## Additional Important Features of McKissick® Roll-Forged Sheaves

- The grain flow associated with the McKissick® Roll-Forged sheave process results in excellent performance properties.
- Each sheave is permanently marked with “McKissick®”, sheave outside diameter, Wireline size and Product Identification Code (PIC) that provides complete material traceability.

**Crosby® and McKissick® Roll-Forged Sheaves  
Reliability You Can Depend On**



**Crosby®**

thecrosbygroup.com

**HEAVY DUTY SHEAVES**  
FROM 12" THROUGH 78"

**Stepped Hub Design Proves Better**

The McKissick hub is stepped to eliminate stress failure in the weld, common in traditional hub designs. The hub is pressed into place with complete metal-to-metal contact. This helps ensure an accurate alignment to the hub's axis so there is no wobble or lopping of the rotating sheave. The precision aligned hub/sheave wheel combination adds to the bearing life and keeps the sheave on the job longer.



**Flame Hardened Groove**

Crosby's hardening technique is a science. It provides a precise maximum hardness for wear-resistance across the wire rope contact area. The McKissick sheave groove is flame hardened to a minimum 35 Rockwell C for a 140° contact area with the wire rope (upon special request the McKissick sheave groove can be flame hardened to a minimum 50 Rockwell C for a 150° contact area with the wire rope). The solid steel plate provides the ideal surface for flame hardening and a closer tolerance fit to the wire rope to reduce fatigue and wear.

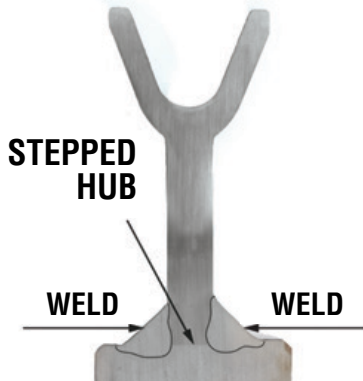

**Full Range of Standard Sheave Sizes**

McKissick Roll-Forged sheaves are available in a full range of sizes from 12 inches to 78 inches, and bearing styles and prices that best fit your application. Crosby also manufactures custom McKissick sheaves and can make minor modifications to standard sheaves as needed for special applications.

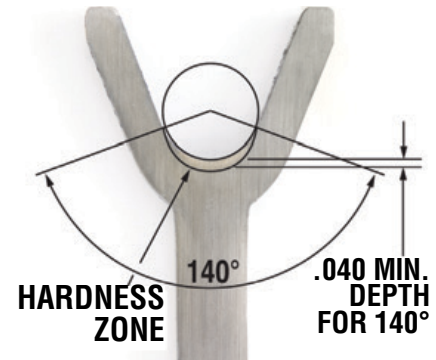

**Closed Die Upset and Roll Forged – Not Split**

Upsetting and roll forging forms the groove and flange walls in multiple steps, eliminating the need to split and weaken the groove. This exclusive forging process adds extra strength to the critical groove section. You can count on a McKissick sheave to give maximum life performance, because it's forged to distribute the wire rope forces evenly over an accurately formed load surface. Plus, uniformity of the roll forged groove adds longer wire rope life.



**Bearing Selection to Match Your Job Requirement**

The McKissick Roll-Forged sheave is available in the following configurations

- Plain bore
- Bronze bushed
- Roller bearing
- Tapered roller bearing
- Lubrication thru hub
- Key ways
- Set screws
- Full Complement Bearing



Licensed Under  
API Spec 8C-0021

Sheaves are available to API 8C.

**Solid Steel – No Casting**

Every McKissick sheave starts as a single piece of solid carbon steel plate. It's flame-cut from closely checked stock, so there's no inherent web/rim flaw as you find in cast sheaves. There's better balance and better distribution of forces with a McKissick Roll-Forged sheave too. Casting can result in groove wall variations – either too thick or too thin – causing uneven stresses and early failure.

**NOTE: Custom Sheaves are Available.  
See Page 287 for Ordering Details.**





## DOMED SHEAVES 24" AND LARGER

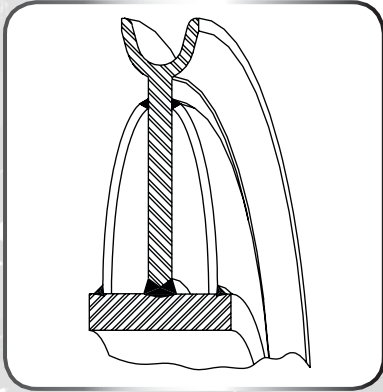

### Eliminates High Stress Weld Intersections

McKissick® Domed Roll-Forged sheaves are welded in a circular pattern thus eliminating the higher stresses created by welding ribs or other forms of stiffeners.



U.S. Patents D621, 240

### Large Range of Sheave Sizes Available

McKissick Domed reinforced Roll-Forged sheaves are available in sizes 24 inches and larger, and bearing styles that best fit your extreme duty applications.



### Roll Forged Sheave and Latest in Welding Technology

McKissick Domed Roll-Forged sheaves have the strength, fatigue properties and rigidity needed for those "extreme duty sheaves" with high working stress and side loading.

## McKissick® Fabricated Sheaves

Custom sheaves are available. See page 287 for ordering details.

## HEAVY DUTY SHEAVES AVAILABLE THROUGH 116" IN OUTSIDE DIAMETER

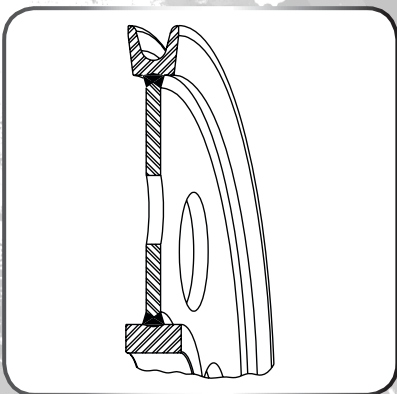

### The Best Solution for Large Sheave Sizes

McKissick fabricated sheaves are available with machined groove rings or machined forged rings utilized for the rim or hub.

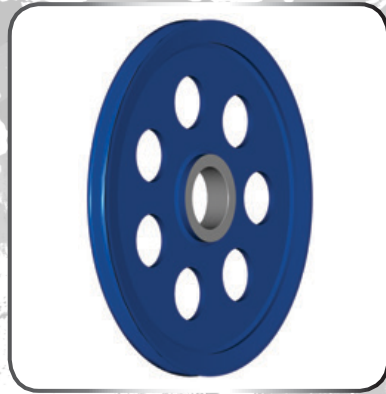

### Large Range of Sheave Sizes Available

McKissick fabricated sheaves are available in multiple sizes, and bearing styles that best fit your heavy duty applications

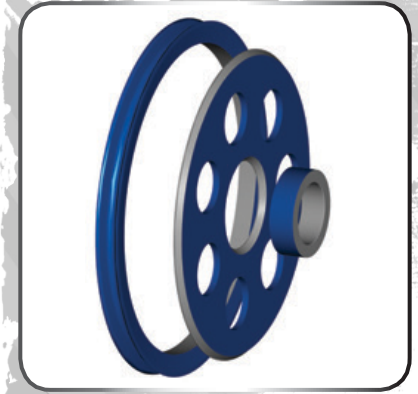

### For Larger Sheave Sizes

McKissick fabricated sheaves are an excellent solution when the required sheave size is too large to be manufactured by the roll forged sheave process.



**HEAVY DUTY SHEAVES**  
FROM 4" THROUGH 12"

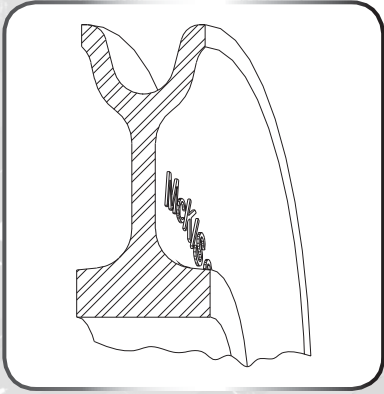

**Closed Die Forging**

McKissick closed die forged sheaves offer the performance of closed die forging with the precision machining capabilities of CNC machinery.

**For Smaller Sheaves in Heavy Duty Application**

McKissick closed die forged sheaves are available in sizes from 4 inches to 12 inches. An extremely effective solution for heavy duty applications where high loads are applied.

Any of the bearings we offer with the roll forged sheaves are available.



**Select Range of Sheave Sizes Available**

McKissick closed die forged sheaves are available in sizes from 4 inches to 12 inches, and bearing styles that best fit your heavy duty applications.

**McKissick® Ductile Iron Sheaves**

*Custom sheaves are available. See page 287 for ordering details.*

**NORMAL SERVICE DUTY SHEAVES**  
FROM 3" THROUGH 16"

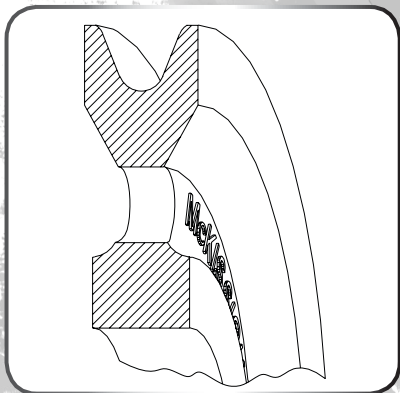

**Machined Ductile Iron**

McKissick ductile iron sheaves are manufactured with material that meets ASTM A-536.

**For Smaller Sheaves in Normal Duty Applications**

McKissick ductile iron sheaves are an acceptable solution for light or normal duty applications where sheaves are protected by sheave guards and minimal side loads are applied.

Standard roller bearings and bronze bushings are typically appropriate for use in these applications.

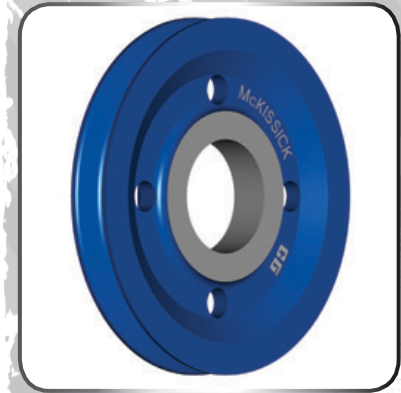

**Select Range of Sheave Sizes Available**

McKissick ductile iron sheaves are available in sizes from 3 inches to 16 inches, and bearing styles that best fit your normal service duty applications.

# McKissick® Sheaves Groove Profile Available

## McKISSICK® Wireline GROOVE PROFILES

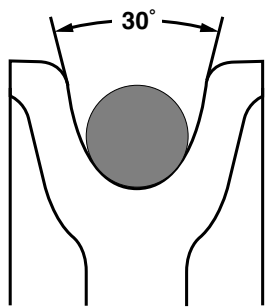

**API STYLE**  
30 degrees

The sheave profile is a very important feature of all sheaves. McKissick manufactures standard sheaves for general use in hoisting wire rope guide applications to minimal API Specifications. The profile includes a groove angle of 30°. This groove profile is used in mobile cranes, drilling rigs, working units, tubing blocks, traveling blocks, crown blocks and many other general hoisting applications.

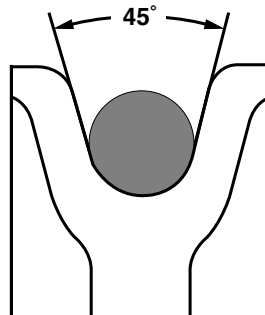

**EUROPEAN STYLE**  
45 degrees

DIN 15061 lifting appliances defines groove profiles for wire rope sheaves

Nominal tread depth is 1.5 times wire rope diameter.

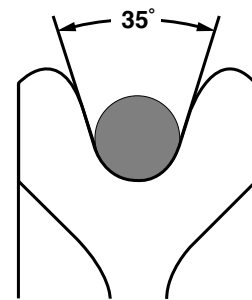

**AISE STYLE**  
35 degrees

McKissick manufactures sheaves to meet the specifications of AISE Standard Number 6. AISE Sheaves must meet specified criteria established by the Association of Iron and Steel Engineers for special use in electric overhead traveling cranes for steel mill service. The profile includes a groove angle of 35°. Dimensional details are also different from the API profile. This groove profile is used in overhead traveling cranes, mobile cranes, portal cranes, power shovels and other equipment using wire rope.

*Contact Crosby for additional available groove angles.*

## McKissick® Sheaves Available to API Standards

- McKissick® products has been licensed by the American Petroleum Institute to manufacture Roll-Forged Sheaves under API specifications 8C. In addition, McKissick® Products is API Q1 certified
- McKissick® Products also produces sheaves to the requirements of API 2C.
- API sheaves must meet the criteria established by the American Petroleum Institute for drilling and production hoisting equipment .
- Typical oilfield applications include: Heavy Haul Trucking, Workover and Well Servicing Units, Tubing Blocks, Traveling Blocks, Crown Blocks and Offshore Cranes.

### API 8C Requires

- Databook
- Material certs and traceability
- D/d ratio per API RP9B
- MPI
- UT of full penetration weld
- 30° groove angle. Groove depth a minimum 1.33 d and maximum 1.75 d, where d=nominal rope diameter.
- Manufactured by an API-8C licensed facility
- Specific groove radii
- Can be furnished to API 8C PSL1 or PSL2

### API 2C Requires

- Material certs and traceability
- D/d ratio 18/1 or greater, based on pitch diameter
- At least 30° groove angle
- Specific groove radii



Licensed Under  
API Spec 8C-0021

# McKissick® Sheaves Bearings Application Information

## (B) Bronze Bushing

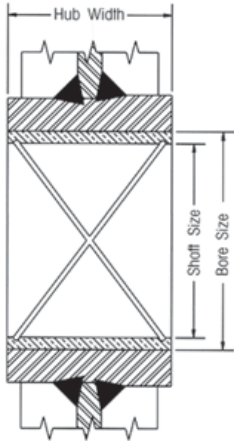

### Bronze Bushing

Slow line speed, moderate load and moderate use

- Maximum Bearing Pressure (BP): 4500 PSI
- Maximum Velocity at Bearing (BV): 1200 FPM
- Maximum Pressure Velocity Factor (PV): 55000

$$\text{Formula for BP} = \frac{\text{Line Pull} \times \text{Angle Factor (See Page 383)}}{\text{Shaft Size} \times \text{Hub Width (See example)}}$$



For underwater sheave applications, special bronze bushings are available. Consult the bearing manufacturer for applicable load.

### Example:

Using a 14 in. sheave (917191) with a 4600 lb line pull and an 80 degree angle between lines, determine maximum allowable line speed.

$$\text{BP} = \frac{\begin{matrix} \text{(Line Pull)} \\ 4600 \text{ lb} \end{matrix} \times \begin{matrix} \text{(Angle Factor)} \\ 1.53 \end{matrix}}{\begin{matrix} \text{(Shaft Size)} \\ 1.50 \end{matrix} \times \begin{matrix} \text{(Hub Width)} \\ 1.62 \end{matrix}} = 2896 \text{ PSI}$$

$$\text{BV} = \frac{\begin{matrix} \text{(PV Factor)} \\ 55000 \end{matrix}}{\begin{matrix} \text{(BP)} \\ 2896 \end{matrix}} = 19 \text{ FPM}$$

## (R) Roller Bearings

### ROLLER BEARINGS

Bronze Bushings with "Figure 8" oil grooves are made from S.A.E. 660 bronze for cold finished shafts

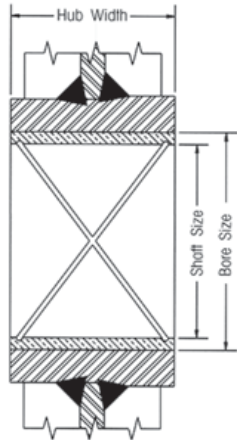

Roller Bearings are designed to operate on shafts carburized to 60 Rockwell C and grounded to +/- .0005 of shaft size.

## (W) Roller Bearing with Thrust Washers

### STANDARD STRAIGHT ROLLER BEARINGS

Heavier loads, higher speeds, more frequent use, radial loads only.

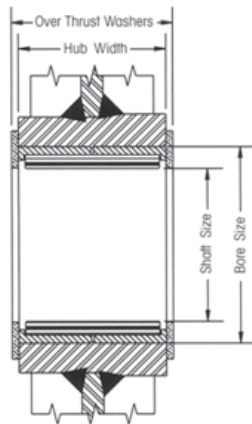

Roller Bearings without inner races are designed to operate on shafts carburized to 60 Rockwell C and grounded to +/- .0005 of shaft size.

## (C) Full Complement Cylindrical Roller Bearing

### FULL COMPLEMENT, DOUBLE ROW, ROLLER BEARING

Heavy load, high speeds, continuous operation, axial and radial loads.

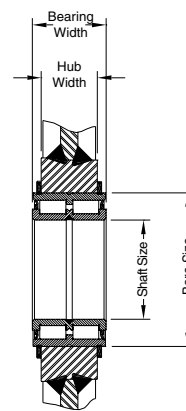

Cylindrical Roller Bearings with snap ring grooves are complete units with outer and inner rings, rib guided cylindrical rollers and sealing rings. They can support axial forces in both directions as well as radial forces. They have high dynamic and static load ratings.

## (T) Tapered Roller Bearing

### TAPERED ROLLER BEARINGS

Heavy loads, high speeds, continuous operation, axial and radial loads.

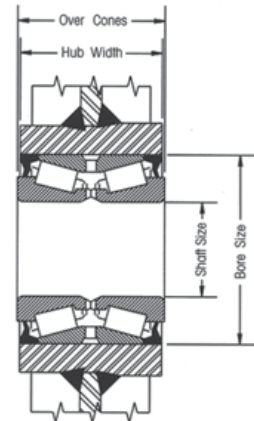

Tapered Bearings are designed to operate on shafts machined to +/- .0005 of shaft size. Applications should provide for tightening separator plates against bearing cones to adjust and insure proper function of bearings.

# McKissick® Sheaves Selection Guide

McKissick® Sheaves come in a variety of sizes to suit your specific applications. Crosby offers many sheaves as standard and these are shown in the pages that follow.

For applications that require unique specifications, Crosby can make minor modifications to many of the sheaves listed at a reasonable charge. We can also custom design and manufacture sheaves to your exact requirements. Contact Crosby Sales to order McKissick® sheaves and include the stock number and quantity. For help in finding that standard sheave or for help with special requirements or custom designed sheaves, furnish the following important information:

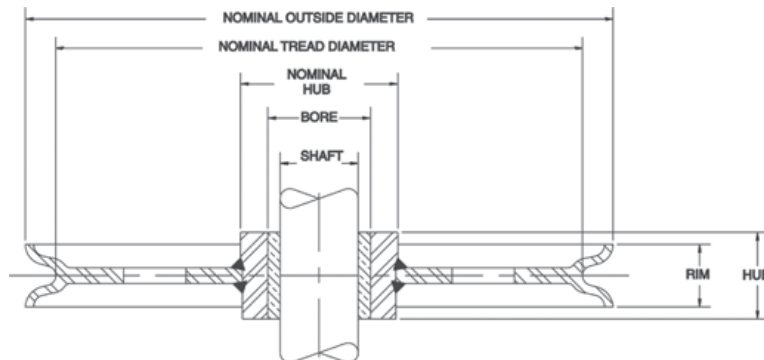

## DIMENSIONAL INFORMATION

Nominal Outside Diameter: \_\_\_\_\_ Wire Rope Size: \_\_\_\_\_ Rim Width: \_\_\_\_\_

+ Shaft Size: \_\_\_\_\_ \*Hub Width: \_\_\_\_\_

Nominal Tread Diameter (Optional): \_\_\_\_\_ Nominal Hub Diameter (Optional): \_\_\_\_\_

\*Hub width is measured over the cone of the Tapered Bearing Sheaves.

+ Shaft Size is Bore Size on Plain Bore Sheaves.

## BEARING TYPE

- Bronze Bushing     
  ++ Roller Bearing     
  Tapered Roller Bearing     
  Finish / Plain Bore  
 Full Complement Cylindrical Roller Bearing     
  Underwater     
  Other

++ Requires hardened and ground shaft

## MATERIAL TYPE

- Roll-Forged (Flame hardened 14" and larger)     
  Forged Steel     
  Domed  
 Cast Steel     
  Fabricated     
  Other

## APPLICATION INFORMATION

Line Pull: \_\_\_\_\_ Fleet Angle: \_\_\_\_\_ Degree of Wrap: \_\_\_\_\_

Line Speed: \_\_\_\_\_ Environment: \_\_\_\_\_ Groove Angle: \_\_\_\_\_

## SPECIAL REQUIREMENTS

Special Testing: \_\_\_\_\_

Finish: \_\_\_\_\_

Third Party Inspection / Approval: \_\_\_\_\_

In USA: Crosby's Special Engineered Product Group at 1-800-777-1555, fax (918) 834-5035, specials@thecrosbygroup.com

In Canada: Crosby Canada at (905) 451-9261

In Europe: N.V. Crosby Europe at 32 15 757125(26).



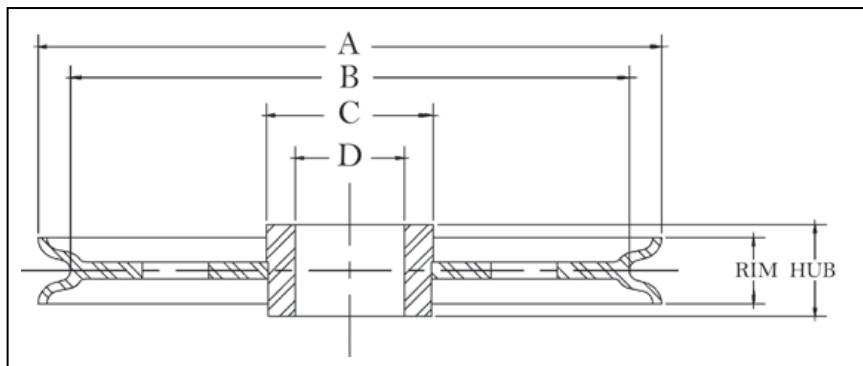

## Finished Bore Sheaves

- Roll-Forged™ sheaves are available in sizes up to 78" in diameter.
- McKissick® Finished Bore Sheaves can be equipped with bushings or bearings at an optional charge.
- 14" diameter sheaves and larger are Roll-Forged with flame hardened grooves to minimum Rockwell 35C

"A" Nominal Outside Diameter (in)	Stock Number	Wire Line Size (in)	"D" Bore Size (in)	Hub Width (in)	Rim Width (in)	"C" Nominal Hub Outside Diameter (in)	"B" Nominal Tread Diameter (in)	Material	Approx. Weight (lb)
3	51008	1/4	.752	1-5/16	1-1/4	1-1/8	2-1/16	B.S.	1.00
3	11310	3/8	.752	1-5/16	1-1/4	1-1/8	2-1/16	B.S.	1.00
4	51053	1/8	1.569	1	7/8	2	3-1/8	B.S.	2.00
4	51044	1/4	1.569	1	7/8	2	3-1/8	B.S.	2.00
4	1189	3/8	1.569	1	7/8	2	3-1/8	B.S.	2.00
4	2023185	3/8	1.569	1-1/2	1-3/8	2	3	F.S.	3.50
4	2023182	1/2	1.569	1-1/2	1-3/8	2	3	F.S.	3.50
4	2023187	5/8	1.569	1-1/2	1-3/8	2	3	F.S.	3.50
4-1/4	50553	3/8	.814	1-3/16	15/16	2-1/8	3-1/8	B.S.	2.40
4-1/4	25939	1/2	.814	1-3/16	15/16	2-1/8	3-1/8	B.S.	2.40
4-3/4	51222	5/16	.875	1-9/16	1-3/8	1-1/2	3-5/8	D.I.	3.50
4-3/4	51231	3/8	.875	1-9/16	1-3/8	1-1/2	3-5/8	D.I.	3.50
4-3/4	11622	1/2	.875	1-9/16	1-3/8	1-1/2	3-5/8	D.I.	3.50
4-7/8	2026411	3/8	1.749	1-1/4	1-1/8	2-1/4	4-1/16	F.S.	3.60
4-7/8	62149	3/8	1.848	1-5/16	1-1/8	2-1/4	4-1/16	F.S.	2.50
4-7/8	2026413	1/2	1.749	1-1/4	1-1/8	2-1/4	4-1/16	F.S.	3.60
4-7/8	2026409	5/8	1.749	1-1/4	1-1/8	2-1/4	4-1/16	F.S.	3.60
5	51071	5/16	1.125	1	7/8	1-1/2	4	F.S.	2.50
5	51062	3/8	1.125	1	7/8	1-1/2	4	F.S.	2.50
5	25948	7/16	1.125	1	7/8	1-1/2	4	F.S.	2.50
5-1/4	2026426	5/8	1.569	1-1/2	1-3/8	2-1/16	3-7/8	F.S.	4.00
5-1/4	2026422	3/4	1.569	1-1/2	1-3/8	2-1/16	3-7/8	F.S.	4.00
5-7/8	2023133	5/8	1.875	1-3/4	1-5/8	2-1/2	4-3/8	F.S.	6.00
5-7/8	2023136	3/4	1.875	1-3/4	1-5/8	2-1/2	4-3/8	F.S.	6.00
5-7/8	2023134	7/8	1.875	1-3/4	1-5/8	2-1/2	4-3/8	F.S.	6.00
6	51124	3/8	1.625	1-1/8	1	2-1/4	4-15/16	F.S.	4.00
6	51375	1/2	1.375	1-1/2	1-1/4	3-1/8	4-3/4	B.S.	7.00
6	13014	1/2	1.625	1-1/8	1	2-1/4	4-15/16	F.S.	4.00
6	60695	1/2	2.375	1-3/4	1-1/4	3-1/8	4-3/4	F.S.	4.70
6	2023263	5/8	2.500	2-5/16	2-3/16	3-1/8	4-1/4	F.S.	9.50
6	1410	3/4	1.375	1-1/2	1-1/4	3-1/8	4-3/4	B.S.	7.00
6	2023257	3/4	2.500	2-5/16	2-3/16	3-1/8	4-1/4	F.S.	9.50
6	2023261	7/8	2.500	2-5/16	2-3/16	3-1/8	4-1/4	F.S.	9.50
7	61872	1/4	1.848	1-5/16	3/4	2-3/8	6-1/4	B.S.	4.00
7	51437	1/4	1.875	1-3/8	3/4	2-3/8	6-1/4	B.S.	6.20
7	3203	3/8	1.875	1-3/8	3/4	2-3/8	6-1/4	B.S.	6.20
7-1/2	2026452	5/8	1.569	1-1/2	1-3/8	2-1/16	6-15/16	F.S.	7.50
7-1/2	2026450	3/4	1.569	1-1/2	1-3/8	2-1/16	6-5/16	F.S.	7.50
7-5/8	51605	3/8	1.569	1-1/2	1-1/4	2-3/8	6-3/16	D.I.	7.00
7-5/8	5498	1/2	1.569	1-1/2	1-1/4	2-3/8	6-3/16	D.I.	7.00
7-5/8	51614	5/8	1.569	1-1/2	1-1/4	2-3/8	6-3/16	D.I.	7.00

Custom sheaves are available. See page 287 for ordering details.

# McKissick® Finished Bore Sheaves

"A" Nominal Outside Diameter (in)	Stock Number	Wire Line Size (in)	"D" Bore Size (in)	Hub Width (in)	Rim Width (in)	"C" Nominal Hub Outside Diameter (in)	"B" Nominal Tread Diameter (in)	Material	Approx. Weight (lb)
8	2023466	1	2.750	2-1/2	2-3/8	4	5-1/4	F.S.	15.0
8	6353	1-1/8	2.750	2-1/2	2-3/8	4	5-3/8	F.S.	15.0
8	2023152	3/4	1.876	1-3/4	1-5/8	2-9/16	6-5/16	F.S.	10.0
8	61710	1/2	1.848	1-5/16	1-1/4	2-7/16	6-5/8	F.S.	8.00
8	51589	1/2	1.875	1-1/2	1-3/8	2-7/16	6-5/8	F.S.	7.00
8	2023144	1/2	1.876	1-3/4	1-5/8	2-9/16	6-5/16	F.S.	10.0
8	51598	5/8	1.875	1-1/2	1-3/8	2-7/16	6-5/8	F.S.	7.00
8	2023146	5/8	1.876	1-3/4	1-5/8	2-9/16	6-5/16	F.S.	10.0
8	5194	3/4	1.875	1-1/2	1-3/8	2-7/16	6-5/8	F.S.	7.00
8	2028226	3/4	2.500	2-5/16	2-1/8	3-1/4	6-1/8	F.S.	12.5
8	2023403	3/4	2.561	2-5/16	2-1/8	3-1/4	6-1/8	F.S.	10.3
8	2023385	7/8	2.500	2-5/16	2-1/8	3-1/4	6-1/8	F.S.	12.5
8	2023765	1-1/8	4.000	2-1/2	2-3/8	5	5-7/16	C.S.	15.0
8-1/2	61747	3/8	1.848	1-5/16	1	2-3/4	7-1/2	D.I.	11.0
9-3/4	2026492	3/8	2.998	2-3/16	1	3-3/4	8-3/4	F.S.	9.00
9-7/8	51918	3/8	3.000	1-3/4	1-1/8	3-3/4	8-9/16	F.S.	14.0
9-7/8	51749	1/2	1.375	1-1/2	1-3/8	3-1/4	8-1/2	F.S.	9.50
9-7/8	2023154	1/2	1.875	1-3/4	1-5/8	2-9/16	8-5/16	F.S.	14.5
9-7/8	6040	1/2	3.000	1-3/4	1-1/8	3-3/4	8-9/16	B.S.	14.0
9-7/8	5675	5/8	1.375	1-1/2	1-3/8	3-1/4	8-1/2	F.S.	9.50
9-7/8	2023169	5/8	1.875	1-3/4	1-5/8	2-9/16	8-5/16	F.S.	14.5
9-7/8	2023173	3/4	1.875	1-3/4	1-5/8	2-9/16	8-5/16	F.S.	14.5
9-7/8	2023435	3/4	2.561	2-5/16	2-3/16	3-1/2	8-1/8	F.S.	16.1
9-7/8	2023419	7/8	2.500	2-5/16	2-3/16	3-1/2	8-1/8	F.S.	15.0
9-7/8	2023427	1	2.500	2-5/16	2-3/16	3-1/2	8-1/8	F.S.	15.0
10	2023484	1-1/8	2.750	2-1/2	2-3/8	4	7-3/8	F.S.	19.0
10	2023784	1-1/8	4.000	2-1/2	2-3/8	5-3/4	7-3/8	F.S.	27.0
11-7/8	62096	1/4	2.998	2-3/16	1	3-3/4	10-3/4	D.I.	12.0
11-7/8	6193	3/8	3.000	2-5/16	1	3-3/4	10-3/4	D.I.	11.2
12	2023247	5/8	1.876	1-3/4	1-5/8	3-1/4	10-1/8	F.S.	18.0
12	2023234	3/4	1.876	1-3/4	1-5/8	3-1/4	9-3/4	F.S.	18.0
12	2023251	7/8	1.876	1-3/4	1-5/8	3-1/4	10-1/4	F.S.	18.0
12	<b>2026531</b>	<b>5/8</b>	<b>3.000</b>	<b>1-3/4</b>	<b>1-5/8</b>	<b>4-1/2</b>	<b>10-1/8</b>	<b>R.F.</b>	<b>16.0</b>
12	<b>52285</b>	<b>3/4</b>	<b>3.000</b>	<b>1-3/4</b>	<b>1-5/8</b>	<b>4-1/2</b>	<b>9-3/4</b>	<b>R.F.</b>	<b>16.0</b>
12	<b>2030851</b>	<b>5/8</b>	<b>2.500</b>	<b>2-5/16</b>	<b>2-3/16</b>	<b>4-1/2</b>	<b>10-1/8</b>	<b>R.F.</b>	<b>24.0</b>
12	<b>2030847</b>	<b>3/4</b>	<b>2.500</b>	<b>2-5/16</b>	<b>2-3/16</b>	<b>4-1/2</b>	<b>9-3/4</b>	<b>R.F.</b>	<b>24.0</b>
12	<b>60007</b>	<b>3/4</b>	<b>2.750</b>	<b>2-5/16</b>	<b>2-3/16</b>	<b>4-1/2</b>	<b>9-3/4</b>	<b>R.F.</b>	<b>24.0</b>
12	<b>2026537</b>	<b>3/4</b>	<b>2.998</b>	<b>2-5/16</b>	<b>2-3/16</b>	<b>4-1/2</b>	<b>9-3/4</b>	<b>R.F.</b>	<b>24.0</b>
12	<b>74724</b>	<b>3/4</b>	<b>2.999</b>	<b>2-5/16</b>	<b>2-3/16</b>	<b>4-1/2</b>	<b>9-3/4</b>	<b>R.F.</b>	<b>24.0</b>
12	<b>2030842</b>	<b>7/8</b>	<b>2.500</b>	<b>2-5/16</b>	<b>2-3/16</b>	<b>4-1/2</b>	<b>10-1/4</b>	<b>R.F.</b>	<b>24.0</b>
12	<b>2023553</b>	<b>7/8</b>	<b>2.750</b>	<b>2-1/2</b>	<b>2-3/8</b>	<b>4-1/2</b>	<b>10-1/4</b>	<b>R.F.</b>	<b>28.0</b>
12	<b>62283</b>	<b>7/8</b>	<b>2.998</b>	<b>2-3/16</b>	<b>2-3/16</b>	<b>4-1/2</b>	<b>10-1/4</b>	<b>R.F.</b>	<b>24.0</b>
12	<b>4016594</b>	<b>7/8</b>	<b>3.000</b>	<b>1-3/4</b>	<b>1-5/8</b>	<b>4-1/2</b>	<b>10-1/4</b>	<b>R.F.</b>	<b>23.0</b>
12	<b>2030845</b>	<b>1</b>	<b>2.500</b>	<b>2-5/16</b>	<b>2-3/16</b>	<b>4</b>	<b>9-3/8</b>	<b>R.F.</b>	<b>24.0</b>
12	2023551	1-1/8	2.750	2-1/2	2-3/8	4-1/2	9-3/8	R.F.	24.0
13	<b>33653</b>	<b>3/8</b>	<b>2.500</b>	<b>1-1/2</b>	<b>1-1/8</b>	<b>3-1/2</b>	<b>11-5/8</b>	<b>R.F.</b>	<b>14.0</b>
13	<b>50704</b>	<b>1/2</b>	<b>2.500</b>	<b>1-1/2</b>	<b>1-1/8</b>	<b>3-1/2</b>	<b>11-5/8</b>	<b>R.F.</b>	<b>14.0</b>
14	<b>2023249</b>	<b>5/8</b>	<b>1.876</b>	<b>1-3/4</b>	<b>1-5/8</b>	<b>3-1/4</b>	<b>12-1/8</b>	<b>R.F.</b>	<b>20.0</b>
14	<b>2023243</b>	<b>3/4</b>	<b>1.876</b>	<b>1-3/4</b>	<b>1-5/8</b>	<b>3-1/4</b>	<b>11-3/4</b>	<b>R.F.</b>	<b>20.0</b>
14	<b>2023250</b>	<b>7/8</b>	<b>1.876</b>	<b>1-3/4</b>	<b>1-5/8</b>	<b>3-1/4</b>	<b>12-1/4</b>	<b>R.F.</b>	<b>20.0</b>
14	<b>2023567</b>	<b>7/8</b>	<b>2.750</b>	<b>2-1/2</b>	<b>2-3/8</b>	<b>4-1/2</b>	<b>12-1/4</b>	<b>R.F.</b>	<b>28.0</b>
14	<b>2023570</b>	<b>1</b>	<b>2.750</b>	<b>2-1/2</b>	<b>2-3/8</b>	<b>4-1/2</b>	<b>11-3/8</b>	<b>R.F.</b>	<b>28.0</b>
14	<b>2023564</b>	<b>1-1/8</b>	<b>2.750</b>	<b>2-1/2</b>	<b>2-3/8</b>	<b>4-1/2</b>	<b>11-3/8</b>	<b>R.F.</b>	<b>28.0</b>
14	<b>* 52720</b>	<b>1/2</b>	<b>4.250</b>	<b>2-1/2</b>	<b>1-3/8</b>	<b>5-1/16</b>	<b>12-5/8</b>	<b>D.I.</b>	<b>15.0</b>
14	<b>4013098</b>	<b>5/8</b>	<b>2.500</b>	<b>1-3/4</b>	<b>1-5/8</b>	<b>4-1/2</b>	<b>12-1/8</b>	<b>R.F.</b>	<b>31.0</b>
14	<b>4013187</b>	<b>5/8</b>	<b>2.375</b>	<b>1-3/4</b>	<b>1-5/8</b>	<b>4-1/2</b>	<b>12-1/8</b>	<b>R.F.</b>	<b>30.0</b>
14	<b>2029220</b>	<b>5/8</b>	<b>4.329</b>	<b>2-3/16</b>	<b>2-1/16</b>	<b>5-3/4</b>	<b>12-1/8</b>	<b>R.F.</b>	<b>30.0</b>
14	<b>4013196</b>	<b>3/4</b>	<b>2.375</b>	<b>1-3/4</b>	<b>1-5/8</b>	<b>4-1/2</b>	<b>11-3/4</b>	<b>R.F.</b>	<b>30.0</b>
14	<b>4013105</b>	<b>3/4</b>	<b>2.500</b>	<b>1-3/4</b>	<b>1-5/8</b>	<b>4-1/2</b>	<b>11-3/4</b>	<b>R.F.</b>	<b>31.0</b>
14	<b>4016503</b>	<b>3/4</b>	<b>3.250</b>	<b>2-5/16</b>	<b>2-3/16</b>	<b>5-1/2</b>	<b>11-3/4</b>	<b>R.F.</b>	<b>34.0</b>
14	<b>2029222</b>	<b>3/4</b>	<b>4.329</b>	<b>2-3/16</b>	<b>2-1/16</b>	<b>5-3/4</b>	<b>11-3/4</b>	<b>R.F.</b>	<b>32.0</b>

McKissick Sheaves

McKissick® Roll-Forged sheaves highlighted above in bold italic are available with reduced lead times due to our advanced manufacturing process.

\*Without flame hardening

Custom sheaves are available. See page 287 for ordering details.

"A" Nominal Outside Diameter (in)	Stock Number	Wire Line Size (in)	"D" Bore Size (in)	Hub Width (in)	Rim Width (in)	"C" Nominal Hub Outside Diameter (in)	"B" Nominal Tread Diameter (in)	Material	Approx. Weight (lb)
14	4013114	7/8	2.500	1-3/4	1-5/8	4-1/2	12-1/4	R.F.	30.0
14	52695	7/8	2.500	2-5/16	2-1/8	4-1/2	12-1/4	R.F.	45.0
16	4010000	1/2	4.248	2-3/4	2-3/8	5-3/4	14-1/4	R.F.	44.0
16	4010046	3/4	4.248	2-3/4	2-1/2	5-3/4	13-3/8	R.F.	25.0
16	4010171	7/8	2.998	2-3/16	2-3/16	4-1/2	12-15/16	R.F.	35.0
16	4013294	7/8	3.000	2-5/16	2-3/16	4-1/2	12-15/16	R.F.	47.0
16	4013258	7/8	3.249	2-5/16	2-3/16	4-1/2	12-15/16	R.F.	47.0
16	4010126	1	4.248	2-3/4	2-1/2	5-3/4	13-3/8	R.F.	42.0
17	62559	5/8	4.722	2-3/4	2-1/2	6-1/2	15	R.F.	52.0
18	2026599	3/4	4.248	2-3/4	2-3/16	6-1/2	16	R.F.	54.0
18	4010493	7/8	3.499	2-5/16	2-3/16	5-1/2	14-15/16	R.F.	64.0
18	2029269	7/8	6.100	2-7/8	2-5/8	8	14-15/16	R.F.	86.0
18	4013490	1	3.250	2-5/16	2-3/16	5-1/2	14-7/8	R.F.	53.0
18	4013524	1	3.499	2-5/16	2-3/16	5-1/2	14-7/8	R.F.	64.0
18	2023608	1	4.500	3	2-3/4	6-1/2	15-1/8	R.F.	60.0
18	2023602	1-1/8	4.500	3	2-3/4	6-1/2	15-1/8	R.F.	60.0
20	*4014024	5/16	4.248	2-3/4	1-3/8	5-3/4	18-7/8	R.F.	45.0
20	4010616	3/4	3.500	2-5/16	2-3/16	5-1/2	18	R.F.	66.0
20	4010885	3/4	4.248	2-3/4	2-1/8	6-1/2	18	R.F.	80.0
20	2029300	7/8	6.100	2-7/8	2-5/8	8	16-15/16	R.F.	70.0
20	4010634	1	3.500	2-5/16	2-3/16	5-1/2	16-1/2	R.F.	81.0
20	4013613	1	3.749	2-5/16	2-3/16	5-1/2	16-1/2	R.F.	76.00
20	2029304	1	6.100	2-7/8	2-5/8	8	16-1/2	R.F.	80.0
20	4010625	7/8	3.500	2-5/16	2-3/16	5-1/2	16-15/16	R.F.	74.0
20	4010901	1	4.248	2-3/4	2-1/8	6-1/2	16-1/2	R.F.	80.0
24	4012749	9/16	6.498	3-3/8	3-1/8	8	22	R.F.	148
24	*4014408	5/8	4.722	2-3/4	1-1/2	6-1/2	21-3/4	R.F.	120
24	2026108	7/8	6.498	3-3/8	3-1/8	8	20-7/8	R.F.	128
24	4011385	1	2.999	2-1/2	2-3/8	4-1/2	21-1/8	R.F.	125
24	4011214	1	4.500	3	2-3/4	6-1/2	21-1/8	R.F.	135
24	4012785	1	6.100	2-7/8	2-5/8	8	21-1/8	R.F.	130
24	2025931	1	6.498	3-3/8	3-1/8	8	21-1/8	R.F.	124
24	4011223	1-1/8	4.500	3	2-3/4	6-1/2	20-1/16	R.F.	130
24	2026646	1-1/8	4.722	2-3/4	2-3/4	6-1/2	20-1/16	R.F.	127
24	4012794	1-1/8	6.100	2-7/8	2-5/8	8	20-1/16	R.F.	120
24	2029333	1-1/8	6.498	3-3/8	3-1/8	8	20-1/16	R.F.	132
24	4011410	1-1/2	6.498	3-3/8	3-1/8	8-1/4	20	R.F.	186
30	2026302	7/8	6.498	3-3/8	3-1/8	8	27	R.F.	187
30	2029351	1	6.498	3-3/8	3-1/8	8	27	R.F.	187
30	2029375	1	7.873	3-1/2	3-1/8	9-1/2	27	R.F.	255
30	2029364	1-1/8	6.498	3-3/8	3-1/8	8	27	R.F.	187
30	2029378	1-1/8	7.873	3-1/2	3-1/8	9-1/2	26-3/8	R.F.	221
30	2029382	1-1/4	7.873	3-1/2	3-1/8	9-1/2	26-3/8	R.F.	225
30	4011839	1-1/2	7.873	3-1/2	3-1/8	9-1/2	26	R.F.	244
36	4012222	1	8.873	3-5/8	3-1/4	11	31-1/4	R.F.	353
36	4012160	1-1/8	6.498	3-3/8	3-1/8	8-1/4	32-1/4	R.F.	341
36	2027080	1-1/8	8.873	3-5/8	3-1/4	11	32-1/4	R.F.	308
36	2027967	1-1/4	7.873	3-1/2	3-1/4	9-1/2	32-1/4	R.F.	340
36	2026695	1-1/4	8.873	3-5/8	3-1/4	11	32-1/4	R.F.	359
36	4012730	1-1/2	7.873	3-1/2	3-1/4	9-1/2	32	R.F.	302
42	4015844	1-1/8	8.873	3-5/8	3-1/4	11	38-1/2	R.F.	460
42	4015728	1-1/8	10.873	3-5/8	3-3/8	12-1/2	38-1/2	R.F.	443
42	4015853	1-1/4	8.873	3-5/8	3-1/4	11	38-3/8	R.F.	460
42	4015719	1-1/4	10.873	3-5/8	3-3/8	12-1/2	38-3/8	R.F.	443
48	4016736	2	13.873	4-1/8	3-3/4	17	42	R.F.	735
50	4016745	1-1/4	13.873	4-1/8	3-3/4	17	46-1/4	R.F.	675
55	4016282	1-1/8	6.498	3-3/8	3	8-1/4	51-1/8	R.F.	537
60	4016754	1-3/8	13.873	4-1/8	3-5/8	17	55-1/2	R.F.	937
60	4016763	1-1/2		4-1/8	3-5/8	17	55-3/8	R.F.	937
64	8060983	2	13.999	6	4-1/4	17	58	R.F.	1145
72	4016772	1-3/4	15.498	4-1/8	3-3/4	19	67	R.F.	1790
78	2032626	2-1/2	16.620	6-13/16	4-15/16	21	71-3/8	R.F./F.	2200

McKissick® Roll-Forged sheaves highlighted above in bold italic are available with reduced lead times due to our advanced manufacturing process.

\*Without flame hardening groove

Custom sheaves are available. See page 287 for ordering details.

# McKissick® Common Bore Sheaves

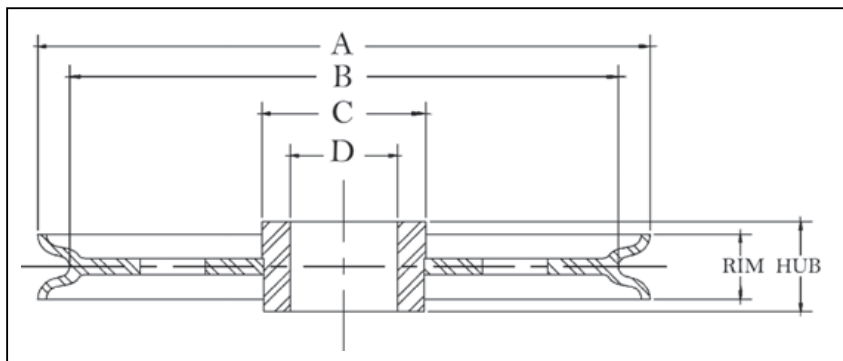

## Common Bore Sheaves

- Roll-Forged sheaves are available in sizes up to 78" in diameter.
- Common Bore or Plain Bore are terms used when there is merely a hole bored in the center of the sheave.
- Common Bore Sheaves are machined for a running fit for the shaft size listed

"A" Nominal Outside Diameter (in)	Stock Number	Wire Line Size (in)	"D" Bore Size (in)	Hub Width (in)	Rim Width (in)	"C" Nominal Hub Outside Diameter (in)	"B" Nominal Tread Diameter (in)	Material	Approx. Weight (lb)
3	905051	3/16	3/8	25/32	3/4	1	2-3/8	P.M.	1.00
3	905079	3/16	1/2	25/32	3/4	1	2-3/8	P.M.	1.00
3	905097	3/16	5/8	25/32	3/4	1	2-3/8	P.M.	1.00
3	905024	1/4	3/8	1/2	1/2	1	2-5/8	P.M.	.75
3	905042	1/4	1/2	1/2	1/2	1	2-5/8	P.M.	.75
3	15410	3/8	3/8	25/32	3/4	1	2-3/8	P.M.	1.00
3	905088	3/8	1/2	25/32	3/4	1	2-3/8	P.M.	1.00
3	905104	3/8	5/8	25/32	3/4	1	2-3/8	P.M.	.60
4	905113	3/16	1/2	3/4	5/8	1-3/8	3-1/2	P.M.	1.00
4	905131	3/16	5/8	3/4	5/8	1-3/8	3-1/2	P.M.	1.00
4	905122	5/16	1/2	3/4	5/8	1-3/8	3-1/2	P.M.	1.00
4	905140	5/16	5/8	3/4	5/8	1-3/8	3-1/2	P.M.	1.00
4	905168	3/8	1/2	13/16	3/4	1-1/2	3-1/4	P.M.	1.25
4	905186	3/8	5/8	13/16	3/4	1-1/2	3-1/4	P.M.	1.25
4	905202	3/8	3/4	13/16	3/4	1-1/2	3-1/4	P.M.	1.25
4	905220	1/2	1/2	1-1/16	1	1-5/8	3-3/16	P.M.	1.50
4	905248	1/2	5/8	1-1/16	1	1-5/8	3-3/16	P.M.	1.50
4	905266	1/2	3/4	1-1/16	1	1-5/8	3-3/16	P.M.	1.50
5	905275	3/16	5/8	15/16	7/8	2-1/4	4-1/4	P.M.	2.25
5	905293	3/16	3/4	15/16	7/8	2-1/4	4-1/4	P.M.	2.25
5	905284	3/8	5/8	15/16	7/8	2-1/4	4-1/4	P.M.	2.75
5	905300	3/8	3/4	15/16	7/8	2-1/4	4-1/4	P.M.	2.25
5	905328	1/2	5/8	1-1/16	1	2-1/4	4	P.M.	2.50
5	905364	1/2	5/8	1-3/16	1-1/8	2-1/4	4	D.I.	4.00
5	905346	1/2	3/4	1-1/16	1	2-1/4	4	P.M.	2.50
5	905382	1/2	3/4	1-3/16	1-1/8	2-1/4	4	D.I.	4.00
5	905408	1/2	7/8	1-3/16	1-1/8	2-1/4	4	D.I.	4.00
6	905426	3/8	1/2	13/16	3/4	1-7/8	5	D.I.	2.50
6	905480	3/8	1/2	1-1/16	1	1-7/8	5	D.I.	2.50
6	905462	3/8	3/4	13/16	3/4	1-7/8	5	P.M.	2.50
6	905523	3/8	3/4	1-1/16	1	1-7/8	5	P.M.	4.16
6	909020	1/2	7/8	1-1/16	1	1-7/8	4-7/8	P.M.	3.75
6	909066	5/8	3/4	1-5/16	1-1/4	1-7/8	4-3/4	P.M.	3.75
6	909084	5/8	7/8	1-5/16	1-1/4	1-7/8	4-3/4	P.M.	3.75
6	909100	5/8	1	1-5/16	1-1/4	1-7/8	4-3/4	P.M.	3.75
6	909164	3/4	1	1-9/16	1-1/2	3	4-5/8	P.M.	6.75
6-3/4	905694	1/4	3/4	1-3/16	1-1/8	2	5-7/8	D.I.	5.00
6-3/4	905710	1/4	1	1-3/16	1-1/8	2	5-7/8	D.I.	5.00
6-3/4	905701	3/8	3/4	1-3/16	1-1/8	2	5-7/8	D.I.	5.00
6-3/4	905729	3/8	1	1-3/16	1-1/8	2	5-7/8	D.I.	5.00
7	905621	1/2	3/4	1-1/16	1	2	5-1/2	D.I.	5.25
7	905649	1/2	7/8	1-1/16	1	2	5-1/2	D.I.	5.25
8	905747	1/2	3/4	1-1/8	1	2-3/8	6-7/8	D.I.	5.00
8	905765	1/2	7/8	1-1/8	1	2-3/8	6-7/8	D.I.	5.00
8	905783	1/2	1	1-1/8	1	2-3/8	6-7/8	D.I.	8.50

McKissick Sheaves

Custom sheaves are available. See page 287 for ordering details.



"A" Nominal Outside Diameter (in)	Stock Number	Wire Line Size (in)	"D" Bore Size (in)	Hub Width (in)	Rim Width (in)	"C" Nominal Hub Outside Diameter (in)	"B" Nominal Tread Diameter (in)	Material	Approx. Weight (lb)
8	905809	5/8	3/4	1-3/8	1-1/4	2	6-1/2	D.I.	6.00
8	905827	5/8	7/8	1-3/8	1-1/4	2	6-1/2	D.I.	6.75
8	909306	5/8	7/8	1-3/8	1-1/4	2-1/2	6-5/8	D.I.	8.50
8	905845	5/8	1	1-3/8	1-1/4	2	6-1/2	D.I.	6.75
8	909324	5/8	1	1-3/8	1-1/4	2-1/2	6-5/8	D.I.	8.50
8	909342	5/8	1-1/8	1-3/8	1-1/4	2-1/2	6-5/8	D.I.	8.50
8	909360	5/8	1-1/4	1-3/8	1-1/4	2-1/2	6-5/8	D.I.	8.50
8	909388	5/8	1-1/2	1-3/8	1-1/4	2-1/2	6-5/8	D.I.	8.50
10	905925	1/2	7/8	1-1/8	1	2-7/8	8-3/4	D.I.	10.0
10	905943	1/2	1	1-1/8	1	2-7/8	8-3/4	D.I.	10.0
10	905961	5/8	3/4	1-3/8	1-1/4	2	8-1/2	D.I.	9.25
10	905989	5/8	7/8	1-3/8	1-1/4	2	8-1/2	D.I.	9.25
10	909681	5/8	7/8	1-3/8	1-1/4	3	8-1/2	D.I.	13.5
10	906005	5/8	1	1-3/8	1-1/4	3	8-1/2	D.I.	9.25
10	909761	5/8	1-1/2	1-3/8	1-1/4	3	8-1/2	D.I.	13.5
12	906041	1/2	1	1-1/8	1	4	10-5/8	D.I.	16.5
12	906087	1/2	1-1/4	1-1/8	1	4	10-5/8	D.I.	16.5
12	906121	3/4	1	1-5/8	1-1/2	2-3/4	10-1/4	D.I.	18.3
12	910107	3/4	1	1-5/8	1-1/2	5-1/4	10-1/4	D.I.	25.5
12	906149	3/4	1-1/8	1-5/8	1-1/2	2-3/4	10-1/4	D.I.	18.3
12	910125	3/4	1-1/8	1-5/8	1-1/2	5-1/4	10-1/4	D.I.	25.5
12	906167	3/4	1-1/4	1-5/8	1-1/2	2-3/4	10-1/4	D.I.	18.3
12	910143	3/4	1-1/4	1-5/8	1-1/2	5-1/4	10-1/4	D.I.	25.5
12	910161	3/4	1-1/2	1-5/8	1-1/2	5-1/4	10-1/4	D.I.	25.5
12	906229	7/8	1-1/4	2	1-3/4	3-3/4	10	D.I.	20.3
12	906247	7/8	1-1/2	2	1-3/4	3-3/4	10	D.I.	20.3
14	*906283	3/4	1-1/8	1-5/8	1-1/2	3-1/4	12-1/4	C.I.	26.5
14	*906309	3/4	1-1/4	1-5/8	1-1/2	3-1/4	12-1/4	C.I.	26.5
14	*910456	7/8	1-1/2	1-5/8	1-1/2	3-1/2	12-1/8	C.I.	34.0
14	*910447	7/8	1-1/4	1-5/8	1-1/2	3-1/2	12-1/8	C.I.	34.0
<b>16</b>	<b>910713</b>	<b>1</b>	<b>2</b>	<b>2</b>	<b>1-3/4</b>	<b>4-1/2</b>	<b>13-5/8</b>	<b>R.F.</b>	<b>47.0</b>
<b>16</b>	<b>910697</b>	<b>1</b>	<b>1-1/2</b>	<b>2</b>	<b>1-3/4</b>	<b>4-1/2</b>	<b>13-5/8</b>	<b>R.F.</b>	<b>47.0</b>
<b>18</b>	<b>910820</b>	<b>1</b>	<b>2</b>	<b>2</b>	<b>1-7/8</b>	<b>4</b>	<b>14-7/8</b>	<b>R.F.</b>	<b>62.0</b>

Material: B.S.=Bar Steel, C.I.=Cast Iron, F.S.=Forged Steel, D.I.=Ductile Iron, C.S.=Cast Steel, P.M.=Powdered Metal, R.F.=Roll-Forged.  
 McKissick® Roll-Forged sheaves highlighted above in bold italic are available with reduced lead times due to our advanced manufacturing process.  
 \*Without flame hardening groove

Custom sheaves are available. See page 287 for ordering details.

# McKissick® Bronze Bushed Sheaves

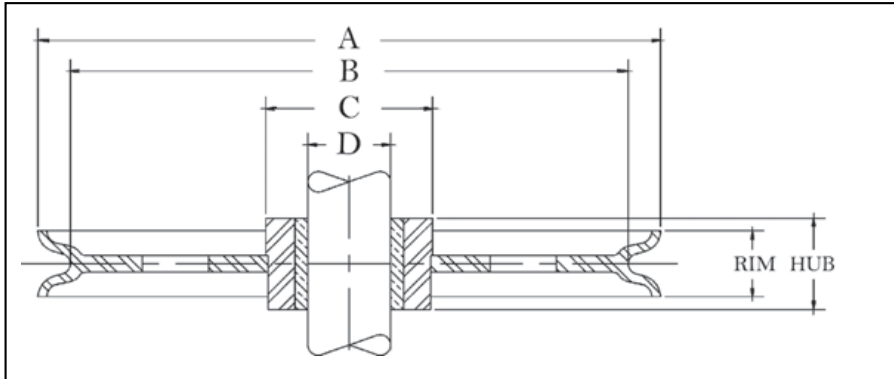

## Bronze Bushed Sheaves

- Roll-Forged sheaves are available in sizes up to 78" in diameter.
- McKissick® Bronze Bushed Sheaves are equipped with S.A.E. 660 Bronze Bushings for cold finished shafts with "Figure 8" oil groove.
- For sizes not listed, McKissick Finished Bore Sheaves can be equipped with bronze bushings at an optional charge.

"A" Nominal Outside Diameter (in)	Stock Number	Wire Line Size (in)	"D" Shaft Size (in)	Hub Width (in)	Rim Width (in)	"C" Nominal Hub Outside Diameter (in)	"B" Nominal Tread Diameter (in)	Material	Approx. Weight (lb)
2-1/4	907004	1/4	3/8*	5/8	9/16	3/4	1-7/8	B.S.	.75
3	907059	3/16	3/8*	25/32	3/4	1	2-3/8	P.M.	1.00
3	907077	3/16	1/2*	25/32	3/4	1	2-3/8	P.M.	1.00
3	907095	3/16	5/8*	25/32	3/4	1	2-3/8	P.M.	1.00
3	907022	1/4	3/8*	1/2	1/2	1	2-5/8	P.M.	.75
3	907040	1/4	1/2*	1/2	1/2	1	2-5/8	P.M.	.75
3	460165	1/4	1/2*	1-5/16	1-3/16	1-1/8	2-1/16	B.S.	1.00
3	2030896	5/16	3/4	1	7/8	1-3/4	2-1/4	P.M.	1.50
3	907068	3/8	3/8*	3/4	3/4	1	2-3/8	P.M.	1.00
3	916101	3/8	3/8*	25/32	3/4	1-1/2	2-3/8	B.S.	1.00
3	907086	3/8	1/2*	3/4	3/4	1	2-3/8	P.M.	1.00
3	916110	3/8	1/2*	25/32	3/4	1-1/2	2-3/8	B.S.	1.00
3	460156	3/8	1/2*	1-5/16	1-3/16	1-1/8	2-1/16	B.S.	1.00
3	907102	3/8	5/8*	3/4	3/4	1	2-3/8	P.M.	1.00
3	2030895	3/8	3/4	1	7/8	1-3/4	2-1/4	P.M.	1.50
3	2023202	7/16	3/4	1	7/8	1-3/4	2-1/4	P.M.	1.50
3	916129	1/2	3/8*	1-1/4	1-1/8	1-7/8	2	B.S.	1.33
3	916138	1/2	1/2*	1-1/4	1-1/8	1-7/8	2	B.S.	1.50
4	460290	1/8	1	1	7/8	2	3-1/8	B.S.	2.00
4	907111	3/16	1/2*	3/4	5/8	1-3/8	3-1/2	P.M.	1.00
4	907139	3/16	5/8*	3/4	5/8	1-3/8	3-1/2	P.M.	1.00
4	916147	1/4	1/2*	13/16	3/4	2	3-1/4	B.S.	1.50
4	916165	1/4	3/4*	13/16	3/4	2	3-1/4	B.S.	1.50
4	460307	1/4	1	1	7/8	2	3-1/8	B.S.	2.00
4	907120	5/16	1/2*	3/4	5/8	1-3/8	3-1/2	P.M.	1.00
4	907148	5/16	5/8*	3/4	5/8	1-3/8	3-1/2	P.M.	1.00
4	907166	3/8	1/2*	13/16	3/4	1-1/2	3-1/4	P.M.	1.25
4	916156	3/8	1/2*	13/16	3/4	2	3-1/4	B.S.	1.50
4	907184	3/8	5/8*	13/16	3/4	1-1/2	3-1/4	P.M.	1.40
4	907200	3/8	3/4*	13/16	3/4	1-1/2	3-1/4	P.M.	1.25
4	460316	3/8	1	1	7/8	2	3-1/8	B.S.	2.00
4	907228	1/2	1/2*	1-1/16	1	1-5/8	3-3/16	P.M.	1.50
4	916192	1/2	1/2*	1-1/8	1	1-5/8	3-3/16	B.S.	2.00
4	907246	1/2	5/8*	1-1/16	1	1-5/8	3-3/16	P.M.	1.50
4	907264	1/2	3/4*	1-1/16	1	1-5/8	3-3/16	P.M.	1.50
4	2028640	3/8	3/4*	13/16	3/4	2	3-1/4	B.S.	1.50
4-1/8	2023186	3/8	1	1-1/2	1-3/8	2	3	F.S.	3.50
4-1/8	2029618	1/2	1	1-1/2	1-3/8	2	3	F.S.	3.50
4-1/8	2023188	5/8	1	1-1/2	1-3/8	2	3	F.S.	3.50
4-1/4	460450	3/8	5/8*	1-3/16	15/16	2-1/8	3-3/8	B.S.	2.40
4-1/4	460441	1/2	5/8*	1-3/16	15/16	2-1/8	3-3/8	B.S.	2.40
4-3/4	460575	5/16	5/8	1-9/16	1-3/8	1-1/2	3-5/8	D.I.	3.50
4-3/4	460584	3/8	5/8	1-9/16	1-3/8	1-1/2	3-5/8	D.I.	3.50
4-3/4	460593	1/2	5/8	1-9/16	1-3/8	1-1/2	3-5/8	D.I.	3.50

\*Self Lubricating Bushing. Custom sheaves are available. See page 287 for ordering details.

## McKissick® Bronze Bushed Sheaves

"A" Nominal Outside Diameter (in)	Stock Number	Wire Line Size (in)	"D" Shaft Size (in)	Hub Width (in)	Rim Width (in)	"C" Nominal Hub Outside Diameter (in)	"B" Nominal Tread Diameter (in)	Material	Approx. Weight (lb)
4-7/8	460478	3/8	1-1/4	1-1/4	1-1/8	2-1/4	4-1/16	F.S.	3.60
4-7/8	2026414	1/2	1-1/4	1-1/4	1-1/8	2-1/4	4-1/16	F.S.	3.60
4-7/8	460469	5/8	1-1/4	1-1/4	1-1/8	2-1/4	4-1/16	F.S.	3.60
5	907273	3/16	5/8*	15/16	7/8	2-1/4	4-1/4	P.M.	2.25
5	907291	3/16	3/4*	15/16	7/8	2-1/4	4-1/4	P.M.	2.25
5	460511	5/16	3/4	1	7/8	1-1/2	4	F.S.	2.50
5	907282	3/8	5/8*	15/16	7/8	2-1/4	4-1/4	P.M.	2.75
5	907308	3/8	3/4*	15/16	7/8	2-1/4	4-1/4	P.M.	2.80
5	460520	3/8	3/4	1	7/8	1-1/2	4	F.S.	2.50
5	460539	7/16	3/4	1	7/8	1-1/2	4	F.S.	2.50
5	907326	1/2	5/8*	1-1/16	1	2-1/4	4	P.M.	2.50
5	907362	1/2	5/8*	1-3/16	1-1/8	2-1/4	4	D.I.	4.00
5	907344	1/2	3/4*	1-1/16	1	2-1/4	4	P.M.	2.50
5	907380	1/2	3/4*	1-3/16	1-1/8	2-1/4	4	D.I.	4.00
5	907406	1/2	7/8*	1-3/16	1-1/8	2-1/4	4	D.I.	4.00
5-1/4	460628	5/8	1	1-1/2	1-3/8	2-1/16	3-7/8	F.S.	4.00
5-1/4	460637	3/4	1	1-1/2	1-3/8	2-1/16	3-7/8	F.S.	4.00
5-7/8	2023129	5/8	1-1/2	1-3/4	1-5/8	2-1/2	4-3/8	F.S.	6.00
5-7/8	2023137	3/4	1-1/2	1-3/4	1-5/8	2-1/2	4-3/8	F.S.	6.00
5-7/8	2023135	7/8	1-1/2	1-3/4	1-5/8	2-1/2	4-3/8	F.S.	6.00
6	907424	3/8	1/2*	13/16	3/4	1-7/8	5	P.M.	2.50
6	907488	3/8	1/2*	1-1/16	1	1-7/8	5	P.M.	2.50
6	907442	3/8	5/8*	13/16	3/4	1-7/8	5	P.M.	2.50
6	907503	3/8	5/8*	1-1/16	1	1-7/8	5	P.M.	2.50
6	907460	3/8	3/4*	13/16	3/4	1-7/8	5	P.M.	2.50
6	907521	3/8	3/4*	1-1/16	1	1-7/8	5	P.M.	4.26
6	2026483	3/8	3/4*	1-1/16	1	2	5-1/8	F.S.	4.00
6	916245	3/8	7/8*	1-1/16	1	2	5-1/8	F.S.	4.00
6	2028641	3/8	1*	1-1/16	1	2	5-1/8	F.S.	4.00
6	460682	3/8	1-1/4	1-1/8	1	2-1/4	4-15/16	F.S.	3.70
6	907549	1/2	5/8*	1-3/16	1-1/8	1-7/8	4-7/8	P.M.	5.00
6	907567	1/2	3/4*	1-3/16	1-1/8	1-7/8	4-7/8	P.M.	4.72
6	913024	1/2	7/8*	1-1/16	1	1-7/8	4-7/8	P.M.	3.75
6	460879	1/2	1	1-1/2	1-1/4	3-1/8	4-3/4	B.S.	7.00
6	460673	1/2	1-1/4*	1-1/8	1	2-1/4	4-15/16	F.S.	3.63
6	2028048	1/2	1	1-1/16	1	1-7/8	4-7/8	P.M.	3.75
6	2026938	5/8	3/4*	1-1/16	1	2	5-1/8	F.S.	4.00
6	913060	5/8	3/4*	1-5/16	1-1/4	1-7/8	4-3/4	P.M.	3.75
6	916254	5/8	7/8*	1-1/16	1	2	5-1/8	F.S.	4.00
6	913088	5/8	7/8*	1-5/16	1-1/4	1-7/8	4-3/4	P.M.	5.00
6	2026822	5/8	1*	1-1/16	1	2	5-1/8	F.S.	4.00
6	913104	5/8	1*	1-5/16	1-1/4	1-7/8	4-3/4	P.M.	3.75
6	2023264	5/8	2	2-5/16	2-3/16	3-1/8	4-1/4	F.S.	9.50
6	460897	3/4	1	1-1/2	1-1/4	3-1/2	4-3/4	B.S.	7.00
6	913168	3/4	1	1-9/16	1-1/2	1-7/8	4-5/8	P.M.	6.75
6	2023260	3/4	2	2-5/16	2-3/16	3-1/8	4-1/4	F.S.	9.50
6	2023262	7/8	2	2-5/16	2-3/16	3-1/2	4-1/4	F.S.	9.50
6-3/4	907692	1/4	3/4*	1-3/16	1-1/8	2	5-7/8	D.I.	5.00
6-3/4	907718	1/4	1*	1-3/16	1-1/8	2	5-7/8	D.I.	5.00
6-3/4	907709	3/8	3/4*	1-3/16	1-1/8	2	5-7/8	D.I.	5.00
6-3/4	907727	3/8	1*	1-3/16	1-1/8	2	5-7/8	D.I.	5.00
7	461020	1/4	1-1/2	1-3/8	3/4	2-3/8	6-1/4	B.S.	6.20
7	461039	3/8	1-1/2	1-3/8	3/4	2-3/8	6-1/4	B.S.	6.20
7	907629	1/2	3/4*	1-1/16	1	2	5-5/8	D.I.	4.25
7	907647	1/2	7/8*	1-1/16	1	2	5-5/8	D.I.	4.25
7-1/2	460986	5/8	1	1-1/2	1-3/8	2-1/16	6-5/16	F.S.	7.50
7-1/2	460977	3/4	1	1-1/2	1-3/8	2-1/16	6-5/16	F.S.	7.50
7-5/8	461262	3/8	1	1-1/2	1-1/4	2-3/8	6-3/16	D.I.	7.00
7-5/8	461280	1/2	1	1-1/2	1-1/4	2-3/8	6-3/16	D.I.	7.00
7-5/8	461271	5/8	1	1-1/2	1-1/4	2-3/8	6-3/16	D.I.	7.00

\*Self Lubricating Bushing.

Custom sheaves are available. See page 287 for ordering details.

# McKissick® Bronze Bushed Sheaves

"A" Nominal Outside Diameter (in)	Stock Number	Wire Line Size (in)	"D" Shaft Size (in)	Hub Width (in)	Rim Width (in)	"C" Nominal Hub Outside Diameter (in)	"B" Nominal Tread Diameter (in)	Material	Approx. Weight (lb)
8	2023467	1	2-1/4	2-1/2	2-3/8	4-1/2	5-3/8	F.S.	18.0
8	2023463	1-1/8	2-1/4	2-1/2	2-3/8	4-1/2	5-3/8	F.S.	18.0
8	2023153	3/4	1-1/2	1-3/4	1-5/8	2-9/16	6-5/16	F.S.	10.0
8	907745	1/2	3/4*	1-1/8	1	2-3/8	6-7/8	D.I.	5.00
8	916487	1/2	3/4*	1-3/8	1-1/4	2	6-5/8	F.S.	7.00
8	907763	1/2	7/8*	1-1/8	1	2-3/8	6-7/8	D.I.	5.00
8	916502	1/2	7/8*	1-3/8	1-1/4	2	6-5/8	F.S.	7.00
8	907781	1/2	1*	1-1/8	1	2-3/8	6-7/8	D.I.	5.59
8	916520	1/2	1*	1-3/8	1-1/4	2	6-5/8	F.S.	7.00
8	2026841	1/2	1-1/8*	1-3/8	1-1/4	2	6-5/8	F.S.	7.00
8	2026844	1/2	1-1/4*	1-3/8	1-1/4	2	6-1/8	F.S.	7.00
8	461235	1/2	1-1/2	1-1/2	1-3/8	2-7/16	6-5/8	F.S.	7.00
8	2023145	1/2	1-1/2	1-3/4	1-5/8	2-9/16	6-5/16	F.S.	10.0
8	907807	5/8	3/4*	1-3/8	1-1/4	2	6-1/2	D.I.	6.75
8	913300	5/8	7/8*	1-3/8	1-1/4	2-1/2	6-5/8	D.I.	8.50
8	913328	5/8	1*	1-3/8	1-1/4	2-3/4	6-5/8	D.I.	7.20
8	913346	5/8	1-1/8*	1-3/8	1-1/4	2-1/2	6-5/8	D.I.	8.50
8	913364	5/8	1-1/4*	1-3/8	1-1/4	2-1/2	6-5/8	D.I.	8.50
8	913382	5/8	1-1/2*	1-3/8	1-1/4	2-1/2	6-5/8	D.I.	8.50
8	461244	5/8	1-1/2	1-1/2	1-3/8	2-7/16	6-1/8	F.S.	7.00
8	2023147	5/8	1-1/2	1-3/4	1-5/8	2-9/16	6-5/16	F.S.	10.0
8	461253	3/4	1-1/2	1-1/2	1-3/8	2-7/16	6	F.S.	7.00
8	2028227	3/4	2	2-5/16	2-1/8	3-1/4	6-1/8	F.S.	12.5
8	461397	3/4	2-3/4	2-5/16	2-3/16	3-3/4	6	R.F.	10.5
8	2023386	7/8	2	2-5/16	2-1/8	3-1/4	6-1/8	F.S.	12.5
8	461501	1-1/8	3-1/2	2-1/2	2-3/8	5	5-7/16	C.S.	15.0
9-7/8	462831	3/8	2-1/2	1-3/4	1-1/8	3-3/4	8-9/16	F.S.	14.0
9-7/8	462154	1/2	1*	1-1/2	1-3/8	3-1/4	8-1/2	F.S.	9.50
9-7/8	2023166	1/2	1-1/2	1-3/4	1-5/8	2-9/16	8-5/16	F.S.	14.5
9-7/8	462840	1/2	2-1/2	1-3/4	1-1/8	3-3/4	8-9/16	F.S.	14.0
9-7/8	462163	5/8	1*	1-1/2	1-3/8	3-1/4	8-1/2	F.S.	9.50
9-7/8	2023170	5/8	1-1/2	1-3/4	1-5/8	2-9/16	8-5/16	F.S.	14.5
9-7/8	2023174	3/4	1-1/2	1-3/4	1-5/8	2-9/16	8-5/16	F.S.	14.5
9-7/8	2023420	7/8	2	2-5/16	2-3/16	3-1/2	8-1/8	F.S.	15.0
9-7/8	2023428	1	2	2-5/16	2-3/16	3-1/2	8-1/8	F.S.	15.0
10	2026861	1-1/8	2-1/4	2-1/2	2-3/8	4-1/2	7-3/8	F.S.	27.0
10	2023785	1-1/8	3-1/2	2-1/2	2-3/8	5-3/4	7-3/8	F.S.	28.0
10	907923	1/2	7/8*	1-1/8	1	2-7/8	8-3/4	D.I.	10.0
10	907941	1/2	1*	1-1/8	1	2-7/8	8-3/4	D.I.	11.8
10	907969	5/8	3/4*	1-3/8	1-1/4	2	8-1/2	D.I.	9.25
10	916717	5/8	7/8*	1-3/8	1-1/4	2-3/4	8-1/2	F.S.	10.0
10	913685	5/8	7/8*	1-3/8	1-1/4	3	8-1/2	D.I.	13.5
10	908003	5/8	1*	1-3/8	1-1/4	2	8-1/2	D.I.	9.25
10	916726	5/8	1*	1-3/8	1-1/4	2-3/4	8-1/2	F.S.	14.0
10	2027291	5/8	1-1/4*	1-3/8	1-1/4	2-3/4	8-1/2	F.S.	14.0
10	913765	5/8	1-1/2*	1-3/8	1-1/4	3	8-1/2	D.I.	12.6
10	913863	3/4	1-1/2*	1-5/8	1-1/2	3-1/2	8-1/4	F.S.	16.0
10	916824	3/4	1-1/4*	1-5/8	1-1/2	3-1/2	7-3/4	F.S.	17.0
10	913845	3/4	1-1/4*	1-5/8	1-1/2	3-1/2	8-1/4	F.S.	16.0
10	916833	3/4	1-1/2*	1-5/8	1-1/2	3-1/4	7-3/4	F.S.	17.0
10	913807	3/4	1*	1-5/8	1-1/2	3-1/2	8-1/4	F.S.	16.0
11-7/8	462323	3/8	2-1/2	2-5/16	1	3-3/4	10-3/4	D.I.	11.2
12	2023227	5/8	1-1/2	1-3/4	1-5/8	3-1/4	10-1/4	F.S.	22.0
12	2023235	3/4	1-1/2	1-3/4	1-5/8	3-1/4	9-3/8	F.S.	22.0
12	2023252	7/8	1-1/2	1-3/4	1-5/8	3-1/4	10-1/4	F.S.	22.0
<b>12</b>	<b>462564</b>	<b>5/8</b>	<b>2-1/2</b>	<b>1-3/4</b>	<b>1-5/8</b>	<b>4-1/2</b>	<b>10-2/3</b>	<b>R.F.</b>	<b>24.0</b>
<b>12</b>	<b>462573</b>	<b>3/4</b>	<b>2-1/2</b>	<b>1-3/4</b>	<b>1-5/8</b>	<b>4-1/2</b>	<b>9-3/8</b>	<b>R.F.</b>	<b>24.0</b>
12	908049	1/2	1*	1-1/8	1	4	10-5/8	D.I.	16.5
12	908085	1/2	1-1/4*	1-1/8	1	4	10-5/8	D.I.	16.5
12	917002	5/8	1*	1-5/8	1-1/2	3-1/4	10-1/8	F.S.	18.0
12	917011	5/8	1-1/8*	1-5/8	1-1/2	3-1/4	10-1/8	F.S.	18.0
<b>12</b>	<b>462387</b>	<b>5/8</b>	<b>2</b>	<b>2-5/16</b>	<b>2-3/16</b>	<b>4-1/2</b>	<b>10-1/8</b>	<b>R.F.</b>	<b>26.0</b>
12	908129	3/4	1*	1-5/8	1-1/2	2-3/4	10-1/4	D.I.	18.3
12	908147	3/4	1-1/8*	1-5/8	1-1/2	2-3/4	10-1/4	D.I.	18.3
12	914121	3/4	1-1/8*	1-5/8	1-1/2	5-1/4	10-1/4	D.I.	25.5

McKissick Sheaves

McKissick® Roll-Forged™ sheaves highlighted above in bold italic are available with reduced lead times due to our advanced manufacturing process. \*Self-lubricating bushing.

Custom sheaves are available. See page 287 for ordering details.



# McKissick® Bronze Bushed Sheaves

"A" Nominal Outside Diameter (in)	Stock Number	Wire Line Size (in)	"D" Shaft Size (in)	Hub Width (in)	Rim Width (in)	"C" Nominal Hub Outside Diameter (in)	"B" Nominal Tread Diameter (in)	Material	Approx. Weight (lb)
12	908147	3/4	1-1/8*	1-5/8	1-1/2	2-3/4	10-1/4	D.I.	18.3
12	914121	3/4	1-1/8*	1-5/8	1-1/2	5-1/4	10-1/4	D.I.	25.5
12	914149	3/4	1-1/4	1-5/8	1-1/2	5-1/4	10-1/4	D.I.	25.5
12	914167	3/4	1-1/2*	1-5/8	1-1/2	5-1/4	10-1/4	D.I.	25.5
12	<b>346593</b>	<b>3/4</b>	<b>2-1/4</b>	<b>2-5/16</b>	<b>2-3/16</b>	<b>4-1/2</b>	<b>9-3/4</b>	<b>R.F.</b>	<b>26.0</b>
12	<b>4104882</b>	<b>3/4</b>	<b>2-1/2</b>	<b>1-3/4</b>	<b>1-5/8</b>	<b>4-1/2</b>	<b>9-3/4</b>	<b>R.F.</b>	<b>25.0</b>
12	<b>462449</b>	<b>3/4</b>	<b>2</b>	<b>2-5/16</b>	<b>2-3/16</b>	<b>4-1/2</b>	<b>9-3/4</b>	<b>R.F.</b>	<b>26.0</b>
12	<b>4104917</b>	<b>3/4</b>	<b>2-1/2</b>	<b>2-5/16</b>	<b>2-3/16</b>	<b>4-1/2</b>	<b>9-3/4</b>	<b>R.F.</b>	<b>25.0</b>
12	<b>462485</b>	<b>3/4</b>	<b>3</b>	<b>3</b>	<b>1-7/8</b>	<b>5-1/2</b>	<b>9-3/8</b>	<b>R.F.</b>	<b>21.0</b>
12	908227	7/8	1-1/4*	2	1-3/4	3-3/4	10	D.I.	20.3
12	908245	7/8	1-1/2*	2	1-3/4	3-3/4	10	D.I.	20.3
12	<b>462458</b>	<b>7/8</b>	<b>2</b>	<b>2-5/16</b>	<b>2-3/16</b>	<b>4-1/2</b>	<b>10-1/4</b>	<b>R.F.</b>	<b>26.0</b>
12	<b>2023554</b>	<b>7/8</b>	<b>2-1/4</b>	<b>2-1/2</b>	<b>2-3/8</b>	<b>4-1/2</b>	<b>9-3/8</b>	<b>R.F.</b>	<b>28.0</b>
12	<b>4104891</b>	<b>7/8</b>	<b>2-1/2</b>	<b>1-3/4</b>	<b>1-5/8</b>	<b>4-1/2</b>	<b>10-1/4</b>	<b>R.F.</b>	<b>25.0</b>
12	<b>462467</b>	<b>1</b>	<b>2</b>	<b>2-5/16</b>	<b>2-3/16</b>	<b>4</b>	<b>10</b>	<b>R.F.</b>	<b>26.0</b>
12	2023552	1-1/8	2-1/4	2-1/2	2-3/8	4-1/2	9-3/8	R.F.	26.0
<b>13</b>	<b>462779</b>	<b>3/8</b>	<b>2</b>	<b>1-1/2</b>	<b>1-1/8</b>	<b>3-1/2</b>	<b>11-5/8</b>	<b>R.F.</b>	<b>14.0</b>
<b>13</b>	<b>462788</b>	<b>1/2</b>	<b>2</b>	<b>1-1/2</b>	<b>1-1/8</b>	<b>3-1/2</b>	<b>11-5/8</b>	<b>R.F.</b>	<b>14.0</b>
14	<b>463625</b>	<b>5/8</b>	<b>1-1/2</b>	<b>1-3/4</b>	<b>1-5/8</b>	<b>3-1/4</b>	<b>12-1/8</b>	<b>R.F.</b>	<b>20.0</b>
14	<b>463634</b>	<b>3/4</b>	<b>1-1/2</b>	<b>1-3/4</b>	<b>1-5/8</b>	<b>3-1/4</b>	<b>11-3/8</b>	<b>R.F.</b>	<b>20.0</b>
14	<b>463643</b>	<b>7/8</b>	<b>1-1/2</b>	<b>1-3/4</b>	<b>1-5/8</b>	<b>3-1/4</b>	<b>11-3/8</b>	<b>R.F.</b>	<b>20.0</b>
14	<b>463448</b>	<b>7/8</b>	<b>2-1/4</b>	<b>2-1/2</b>	<b>2-3/8</b>	<b>4-1/2</b>	<b>12-1/4</b>	<b>R.F.</b>	<b>28.0</b>
14	<b>463457</b>	<b>1</b>	<b>2-1/4</b>	<b>2-1/2</b>	<b>2-3/8</b>	<b>4-1/2</b>	<b>11-3/8</b>	<b>R.F.</b>	<b>28.0</b>
14	<b>463466</b>	<b>1-1/8</b>	<b>2-1/4</b>	<b>2-1/2</b>	<b>2-3/8</b>	<b>4-1/2</b>	<b>11-3/8</b>	<b>R.F.</b>	<b>28.0</b>
14	<b>**463518</b>	<b>1/2</b>	<b>3-3/4</b>	<b>2-1/2</b>	<b>1-3/8</b>	<b>5-1/16</b>	<b>12-5/8</b>	<b>R.F.</b>	<b>15.0</b>
14	<b>4103552</b>	<b>5/8</b>	<b>2</b>	<b>1-3/4</b>	<b>1-5/8</b>	<b>4-1/2</b>	<b>12-1/8</b>	<b>R.F.</b>	<b>29.2</b>
14	<b>**908281</b>	<b>3/4</b>	<b>1-1/8*</b>	<b>1-5/8</b>	<b>1-7/16</b>	<b>3-1/4</b>	<b>12-1/4</b>	<b>C.I.</b>	<b>26.5</b>
14	<b>**908307</b>	<b>3/4</b>	<b>1-1/4*</b>	<b>1-5/8</b>	<b>1-1/2</b>	<b>3-1/4</b>	<b>12-1/4</b>	<b>C.I.</b>	<b>26.5</b>
14	<b>917173</b>	<b>3/4</b>	<b>1-1/4*</b>	<b>1-5/8</b>	<b>1-1/2</b>	<b>4</b>	<b>12</b>	<b>R.F.</b>	<b>26.5</b>
14	<b>917191</b>	<b>3/4</b>	<b>1-1/2*</b>	<b>1-5/8</b>	<b>1-1/2</b>	<b>3-1/4</b>	<b>11-3/4</b>	<b>R.F.</b>	<b>26.5</b>
14	<b>4103632</b>	<b>3/4</b>	<b>2</b>	<b>1-3/4</b>	<b>1-5/8</b>	<b>4-1/2</b>	<b>11-3/4</b>	<b>R.F.</b>	<b>30.0</b>
14	<b>4104828</b>	<b>3/4</b>	<b>2-3/4</b>	<b>2-5/16</b>	<b>2-3/16</b>	<b>5-1/2</b>	<b>11-3/4</b>	<b>R.F.</b>	<b>35.0</b>
14	<b>917182</b>	<b>7/8</b>	<b>1-1/4*</b>	<b>1-5/8</b>	<b>1-1/2</b>	<b>4</b>	<b>12</b>	<b>R.F.</b>	<b>26.5</b>
14	<b>917208</b>	<b>7/8</b>	<b>1-1/2*</b>	<b>1-5/8</b>	<b>1-1/2</b>	<b>4</b>	<b>12</b>	<b>R.F.</b>	<b>26.5</b>
14	<b>463484</b>	<b>7/8</b>	<b>2</b>	<b>2-5/16</b>	<b>2-1/8</b>	<b>4-1/2</b>	<b>11-3/8</b>	<b>R.F.</b>	<b>28.0</b>
14	<b>4103641</b>	<b>7/8</b>	<b>2</b>	<b>1-3/4</b>	<b>1-5/8</b>	<b>4-1/2</b>	<b>12-1/4</b>	<b>R.F.</b>	<b>31.0</b>
16	<b>4101395</b>	<b>1/2</b>	<b>3-1/2</b>	<b>2-3/4</b>	<b>2-1/2</b>	<b>5-3/4</b>	<b>14-1/4</b>	<b>R.F.</b>	<b>54.0</b>
16	<b>4100047</b>	<b>3/4</b>	<b>3-1/2</b>	<b>2-3/4</b>	<b>2-1/2</b>	<b>5-3/4</b>	<b>13-3/8</b>	<b>R.F.</b>	<b>47.0</b>
16	<b>4100109</b>	<b>3/4</b>	<b>3-3/4</b>	<b>2-3/4</b>	<b>2-1/2</b>	<b>5-3/4</b>	<b>13-3/8</b>	<b>R.F.</b>	<b>42.0</b>
16	<b>4103703</b>	<b>7/8</b>	<b>2-1/2</b>	<b>2-5/16</b>	<b>2-3/16</b>	<b>4-1/2</b>	<b>12-15/16</b>	<b>R.F.</b>	<b>35.0</b>
16	<b>4105211</b>	<b>7/8</b>	<b>2-3/4</b>	<b>2-5/16</b>	<b>2-3/16</b>	<b>4-1/2</b>	<b>12-15/16</b>	<b>R.F.</b>	<b>42.0</b>
16	<b>917342</b>	<b>1</b>	<b>1-1/2*</b>	<b>2</b>	<b>1-3/4</b>	<b>4-1/4</b>	<b>13-1/4</b>	<b>R.F.</b>	<b>34.0</b>
16	<b>917360</b>	<b>1</b>	<b>2*</b>	<b>2</b>	<b>1-3/4</b>	<b>4-1/4</b>	<b>13-1/4</b>	<b>R.F.</b>	<b>34.0</b>
16	<b>4100127</b>	<b>1</b>	<b>3-3/4</b>	<b>2-3/4</b>	<b>2-1/2</b>	<b>5-3/4</b>	<b>13-1/4</b>	<b>R.F.</b>	<b>63.0</b>
18	<b>4105131</b>	<b>7/8</b>	<b>3</b>	<b>2-5/16</b>	<b>2-3/16</b>	<b>5-1/2</b>	<b>14-15/16</b>	<b>R.F.</b>	<b>52.0</b>
18	<b>4105195</b>	<b>7/8</b>	<b>5-1/2</b>	<b>2-7/8</b>	<b>2-5/8</b>	<b>8</b>	<b>14-15/16</b>	<b>R.F.</b>	<b>59.0</b>
18	<b>917468</b>	<b>1</b>	<b>1-1/2*</b>	<b>2</b>	<b>1-7/8</b>	<b>3-1/4</b>	<b>14-7/8</b>	<b>R.F.</b>	<b>55.0</b>
18	<b>917486</b>	<b>1</b>	<b>2*</b>	<b>2</b>	<b>1-7/8</b>	<b>4-1/2</b>	<b>14-7/8</b>	<b>R.F.</b>	<b>55.0</b>
18	<b>914826</b>	<b>1</b>	<b>2*</b>	<b>2</b>	<b>1-3/4</b>	<b>5-3/4</b>	<b>15-3/4</b>	<b>R.F.</b>	<b>62.0</b>
18	<b>4104052</b>	<b>1</b>	<b>2-3/4</b>	<b>2-5/16</b>	<b>2-3/16</b>	<b>5-1/2</b>	<b>14-7/8</b>	<b>R.F.</b>	<b>66.0</b>
18	<b>4105140</b>	<b>1</b>	<b>3</b>	<b>2-5/16</b>	<b>2-3/16</b>	<b>5-1/2</b>	<b>14-7/8</b>	<b>R.F.</b>	<b>52.0</b>
18	<b>4100298</b>	<b>1</b>	<b>4</b>	<b>3</b>	<b>2-3/4</b>	<b>6-1/2</b>	<b>15-1/8</b>	<b>R.F.</b>	<b>81.0</b>
18	<b>4103348</b>	<b>1-1/8</b>	<b>4</b>	<b>3</b>	<b>2-3/4</b>	<b>6-1/2</b>	<b>15-1/8</b>	<b>R.F.</b>	<b>60.0</b>
20	<b>4100341</b>	<b>3/4</b>	<b>3</b>	<b>2-5/16</b>	<b>2-3/16</b>	<b>5-1/2</b>	<b>18</b>	<b>R.F.</b>	<b>68.0</b>
20	<b>4105239</b>	<b>3/4</b>	<b>3-3/4</b>	<b>2-3/4</b>	<b>2-1/8</b>	<b>6-1/2</b>	<b>18</b>	<b>R.F.</b>	<b>68.0</b>
20	<b>4100350</b>	<b>7/8</b>	<b>3</b>	<b>2-5/16</b>	<b>2-3/16</b>	<b>5-1/2</b>	<b>17-1/8</b>	<b>R.F.</b>	<b>45.0</b>
20	<b>4105266</b>	<b>7/8</b>	<b>5-1/2</b>	<b>2-7/8</b>	<b>2-5/8</b>	<b>8</b>	<b>16-15/16</b>	<b>R.F.</b>	<b>68.0</b>
20	<b>4100369</b>	<b>1</b>	<b>3</b>	<b>2-5/16</b>	<b>2-3/16</b>	<b>5-1/2</b>	<b>17-1/8</b>	<b>R.F.</b>	<b>80.2</b>
20	<b>4105328</b>	<b>1</b>	<b>3-1/4</b>	<b>2-5/16</b>	<b>2-3/16</b>	<b>5-1/2</b>	<b>17-1/8</b>	<b>R.F.</b>	<b>68.0</b>
20	<b>4105257</b>	<b>1</b>	<b>3-3/4</b>	<b>2-3/4</b>	<b>2-1/8</b>	<b>6-1/2</b>	<b>16-1/2</b>	<b>R.F.</b>	<b>68.0</b>
20	<b>4105275</b>	<b>1</b>	<b>5-1/2</b>	<b>2-7/8</b>	<b>2-5/8</b>	<b>8</b>	<b>17-1/8</b>	<b>R.F.</b>	<b>68.0</b>
24	<b>4105346</b>	<b>9/16</b>	<b>5-3/4</b>	<b>3-3/8</b>	<b>3-1/8</b>	<b>8</b>	<b>22</b>	<b>R.F.</b>	<b>113</b>
24	<b>4105355</b>	<b>7/8</b>	<b>5-3/4</b>	<b>3-3/8</b>	<b>3-1/8</b>	<b>8</b>	<b>21</b>	<b>R.F.</b>	<b>133</b>
24	<b>4100859</b>	<b>1</b>	<b>4</b>	<b>3</b>	<b>2-3/4</b>	<b>9</b>	<b>21-1/8</b>	<b>R.F.</b>	<b>140.0</b>

McKissick® Roll-Forged™ sheaves highlighted above in bold italic are available with reduced lead times due to our advanced manufacturing process.

\*\* Without Flame Harden groove.

\*Self Lubricating Bushing.

# McKissick® Bronze Bushed Sheaves

"A" Nominal Outside Diameter (in)	Stock Number	Wire Line Size (in)	"D" Shaft Size (in)	Hub Width (in)	Rim Width (in)	"C" Nominal Hub Outside Diameter (in)	"B" Nominal Tread Diameter (in)	Material	Approx. Weight (lb)
<b>24</b>	<b>4105382</b>	<b>1</b>	<b>5-1/2</b>	<b>2-7/8</b>	<b>2-5/8</b>	<b>8</b>	<b>21-1/8</b>	<b>R.F.</b>	<b>130</b>
<b>24</b>	<b>4100868</b>	<b>1-1/8</b>	<b>4</b>	<b>3</b>	<b>2-3/4</b>	<b>6-1/2</b>	<b>20-1/16</b>	<b>R.F.</b>	<b>110</b>
<b>24</b>	<b>4105391</b>	<b>1-1/8</b>	<b>5-1/2</b>	<b>2-7/8</b>	<b>2-5/8</b>	<b>8</b>	<b>20-1/16</b>	<b>R.F.</b>	<b>134</b>
<b>24</b>	<b>4105373</b>	<b>1-1/8</b>	<b>5-3/4</b>	<b>3-3/8</b>	<b>3-1/8</b>	<b>8</b>	<b>20-1/16</b>	<b>R.F.</b>	<b>137</b>
<b>30</b>	<b>4105426</b>	<b>7/8</b>	<b>5-3/4</b>	<b>3-3/8</b>	<b>3-1/8</b>	<b>8</b>	<b>27</b>	<b>R.F.</b>	<b>203</b>
30	4101215	7/8	6	3-1/2	3-1/8	8	27	R.F.	140
<b>30</b>	<b>4105435</b>	<b>1</b>	<b>5-3/4</b>	<b>3-3/8</b>	<b>3-1/8</b>	<b>8</b>	<b>27</b>	<b>R.F.</b>	<b>203</b>
<b>30</b>	<b>4105453</b>	<b>1</b>	<b>7</b>	<b>3-1/2</b>	<b>3-1/8</b>	<b>9-1/2</b>	<b>27</b>	<b>R.F.</b>	<b>211</b>
<b>30</b>	<b>4105444</b>	<b>1-1/8</b>	<b>5-3/4</b>	<b>3-3/8</b>	<b>3-1/8</b>	<b>8</b>	<b>27</b>	<b>R.F.</b>	<b>203</b>
<b>30</b>	<b>4105462</b>	<b>1-1/8</b>	<b>7</b>	<b>3-1/2</b>	<b>3-1/8</b>	<b>9-1/2</b>	<b>26-3/8</b>	<b>R.F.</b>	<b>211</b>
<b>30</b>	<b>4105471</b>	<b>1-1/4</b>	<b>7</b>	<b>3-1/2</b>	<b>3-1/8</b>	<b>9-1/2</b>	<b>26-3/8</b>	<b>R.F.</b>	<b>211</b>

Material: B.S.=Bar Steel, C.I.=Cast Iron, F.S.=Forged Steel, D.I.=Ductile Iron, C.S.=Cast Steel, P.M.=Powdered Metal, R.F.=Roll-Forged.

# McKissick® Roller Bearing Sheaves

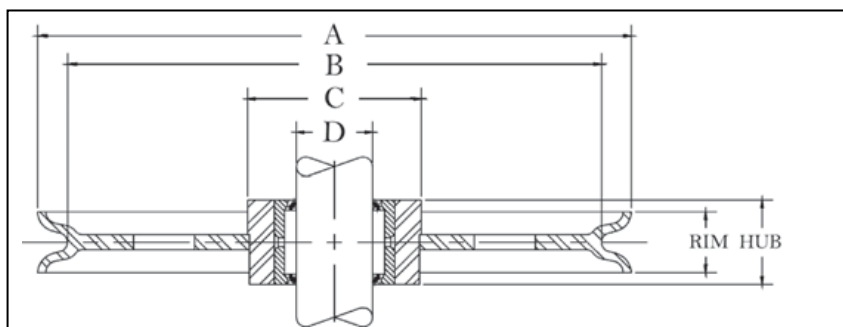

McKissick Sheaves

## Roller Bearing Sheaves

- Roll-Forged sheaves are available in sizes up to 78" in diameter.
- McKissick® Roller Bearing Sheaves are designed to operate on shafts carburized to 60 Rockwell C and groove to +/- .0005 of the indicated shaft size. Some sizes are available with an optional inner race. Check with Crosby Sales for prices and correct shaft size.
- Application should provide for 1/32" running clearance over the hub width.
- For sizes not listed, McKissick Finished Bore Sheaves can be equipped with Roller Bearings at an optional charge.

"A" Nominal Outside Diameter (in)	Stock Number	Wire Line Size (in)	"D" Shaft Size (in)	Hub Width (in)	Rim Width (in)	"C" Nominal Hub Outside Diameter (in)	"B" Nominal Tread Diameter (in)	Material	Approx. Weight (lb)
<b>4</b>	<b>472508</b>	<b>1/8</b>	<b>.997</b>	<b>1</b>	<b>7/8</b>	<b>2</b>	<b>3-1/8</b>	<b>B.S.</b>	<b>2.00</b>
<b>4</b>	<b>472517</b>	<b>1/4</b>	<b>.997</b>	<b>1</b>	<b>7/8</b>	<b>2</b>	<b>3-1/8</b>	<b>B.S.</b>	<b>2.00</b>
<b>4</b>	<b>472535</b>	<b>3/8</b>	<b>.997</b>	<b>1</b>	<b>7/8</b>	<b>2</b>	<b>3-1/8</b>	<b>B.S.</b>	<b>2.00</b>
<b>4</b>	<b>2025893</b>	<b>3/8</b>	<b>.997</b>	<b>1-1/2</b>	<b>1-3/8</b>	<b>2</b>	<b>3</b>	<b>F.S.</b>	<b>3.50</b>
<b>4</b>	<b>2028063</b>	<b>1/2</b>	<b>.997</b>	<b>1-1/2</b>	<b>1-3/8</b>	<b>2</b>	<b>3</b>	<b>F.S.</b>	<b>3.50</b>
<b>4</b>	<b>2025891</b>	<b>5/8</b>	<b>.997</b>	<b>1-1/2</b>	<b>1-3/8</b>	<b>2</b>	<b>3</b>	<b>F.S.</b>	<b>3.50</b>
<b>4-7/8</b>	<b>472768</b>	<b>3/8</b>	<b>1.247</b>	<b>1-1/4</b>	<b>1-1/8</b>	<b>2-1/4</b>	<b>4-1/16</b>	<b>F.S.</b>	<b>3.60</b>
<b>4-7/8</b>	<b>472777</b>	<b>1/2</b>	<b>1.247</b>	<b>1-1/4</b>	<b>1-1/8</b>	<b>2-1/4</b>	<b>4-1/16</b>	<b>F.S.</b>	<b>3.60</b>
<b>4-7/8</b>	<b>472786</b>	<b>5/8</b>	<b>1.247</b>	<b>1-1/4</b>	<b>1-1/8</b>	<b>2-1/4</b>	<b>4-1/16</b>	<b>F.S.</b>	<b>3.60</b>
<b>5-1/4</b>	<b>2026427</b>	<b>5/8</b>	<b>.997</b>	<b>1-1/2</b>	<b>1-3/8</b>	<b>2-1/16</b>	<b>3-7/8</b>	<b>F.S.</b>	<b>4.00</b>
<b>5-1/4</b>	<b>2026423</b>	<b>3/4</b>	<b>.997</b>	<b>1-1/2</b>	<b>1-3/8</b>	<b>2-1/16</b>	<b>3-7/8</b>	<b>F.S.</b>	<b>4.00</b>
<b>5-7/8</b>	<b>2023141</b>	<b>5/8</b>	<b>1.497</b>	<b>1-3/4</b>	<b>1-5/8</b>	<b>2-1/2</b>	<b>4-3/8</b>	<b>F.S.</b>	<b>6.00</b>
<b>5-7/8</b>	<b>2023143</b>	<b>3/4</b>	<b>1.497</b>	<b>1-3/4</b>	<b>1-5/8</b>	<b>2-1/2</b>	<b>4-3/8</b>	<b>F.S.</b>	<b>6.00</b>
<b>5-7/8</b>	<b>2023142</b>	<b>7/8</b>	<b>1.497</b>	<b>1-3/4</b>	<b>1-5/8</b>	<b>2-1/2</b>	<b>4-3/8</b>	<b>F.S.</b>	<b>6.00</b>

McKissick® Roll-Forged sheaves highlighted above in bold italic are available with reduced lead times due to our advanced manufacturing process.

\* Without Flame Harden groove.

# McKissick® Roller Bearing Sheaves

"A" Nominal Outside Diameter (in)	Stock Number	Wire Line Size (in)	"D" Shaft Size (in)	Hub Width (in)	Rim Width (in)	"C" Nominal Hub Outside Diameter (in)	"B" Nominal Tread Diameter (in)	Material	Approx. Weight (lb)
6	472875	1/2	1.997	1-3/4	1-1/4	3-1/8	4-3/4	F.S.	7.00
7-1/2	2025898	5/8	.997	1-1/2	1-3/8	2-1/16	6-5/16	F.S.	7.50
7-1/2	2025892	3/4	.997	1-1/2	1-3/8	2-1/16	6-5/16	F.S.	7.50
7-5/8	473311	3/8	.997	1-1/2	1-1/4	2-3/8	6-3/16	D.I.	7.00
7-5/8	473320	1/2	.997	1-1/2	1-1/4	2-3/8	6-3/16	D.I.	7.00
7-5/8	473339	5/8	.997	1-1/2	1-1/4	2-3/8	6-3/16	D.I.	7.00
8	2023163	3/4	1.497	1-3/4	1-5/8	2-9/16	6-5/16	F.S.	10.0
8	2023155	1/2	1.497	1-3/4	1-5/8	2-9/16	6-5/16	F.S.	10.0
8	2023159	5/8	1.497	1-3/4	1-5/8	2-9/16	6-5/16	F.S.	10.0
8	2023404	3/4	1.997	2-5/16	2-1/8	3-1/4	6-1/8	F.S.	12.5
9-7/8	2026433	1/2	1.497	1-3/4	1-5/8	2-9/16	8-5/16	F.S.	14.5
9-7/8	2023179	5/8	1.497	1-3/4	1-5/8	2-9/16	8-5/16	F.S.	14.5
9-7/8	2023181	3/4	1.497	1-3/4	1-5/8	2-9/16	8-5/16	F.S.	14.5
9-7/8	2023436	3/4	1.997	2-5/16	2-3/16	3-1/2	8-1/8	F.S.	15.0
12	2023248	5/8	1.497	1-3/4	1-5/8	3-1/4	10-1/8	F.S.	18.0
12	2023236	3/4	1.497	1-3/4	1-5/8	3-1/4	9-3/4	F.S.	18.0
12	2026441	7/8	1.497	1-3/4	1-5/8	3-1/4	10-1/4	F.S.	18.0
12	<b>474365</b>	<b>5/8</b>	<b>2.247</b>	<b>1-3/4</b>	<b>1-5/8</b>	<b>4-1/2</b>	<b>10-1/8</b>	<b>R.F.</b>	<b>16.0</b>
12	<b>474374</b>	<b>3/4</b>	<b>2.247</b>	<b>1-3/4</b>	<b>1-5/8</b>	<b>4-1/2</b>	<b>9-3/4</b>	<b>R.F.</b>	<b>16.0</b>
14	<b>2026445</b>	<b>5/8</b>	<b>1.497</b>	<b>1-3/4</b>	<b>1-5/8</b>	<b>3-1/4</b>	<b>12</b>	<b>R.F.</b>	<b>20.0</b>
14	<b>2026444</b>	<b>3/4</b>	<b>1.497</b>	<b>1-3/4</b>	<b>1-5/8</b>	<b>3-1/4</b>	<b>11-3/4</b>	<b>R.F.</b>	<b>20.0</b>
14	<b>474784</b>	<b>7/8</b>	<b>1.497</b>	<b>1-3/4</b>	<b>1-5/8</b>	<b>3-1/4</b>	<b>12-1/4</b>	<b>R.F.</b>	<b>20.0</b>
14	<b>4200563</b>	<b>5/8</b>	<b>1.997</b>	<b>1-3/4</b>	<b>1-5/8</b>	<b>4-1/2</b>	<b>12-1/8</b>	<b>R.F.</b>	<b>31.0</b>
14	<b>4200572</b>	<b>3/4</b>	<b>1.997</b>	<b>1-3/4</b>	<b>1-5/8</b>	<b>4-1/2</b>	<b>11-3/4</b>	<b>R.F.</b>	<b>31.0</b>
16	<b>4200705</b>	<b>7/8</b>	<b>2.497</b>	<b>2-5/16</b>	<b>2-3/16</b>	<b>4-1/2</b>	<b>12-15/16</b>	<b>R.F.</b>	<b>48.0</b>
18	<b>4201438</b>	<b>7/8</b>	<b>2.747</b>	<b>2-5/16</b>	<b>2-3/16</b>	<b>5-1/2</b>	<b>14-15/16</b>	<b>R.F.</b>	<b>42.7</b>
18	<b>4200867</b>	<b>1</b>	<b>2.747</b>	<b>2-5/16</b>	<b>2-3/16</b>	<b>5-1/2</b>	<b>14-7/8</b>	<b>R.F.</b>	<b>66.0</b>
20	<b>4200929</b>	<b>1</b>	<b>2.997</b>	<b>2-5/16</b>	<b>2-3/16</b>	<b>5-1/2</b>	<b>16-1/2</b>	<b>R.F.</b>	<b>77.0</b>
24	<b>4200117</b>	<b>1</b>	<b>2.247</b>	<b>2-1/2</b>	<b>2-3/8</b>	<b>5-1/2</b>	<b>21-1/8</b>	<b>R.F.</b>	<b>75.0</b>

Material: B.S.=Bar Steel, C.I.=Cast Iron, F.S.=Forged Steel, D.I.=Ductile Iron, C.S.=Cast Steel, P.M.=Powdered Metal, R.F.=Roll-Forged.

McKissick® Roll-Forged sheaves highlighted above in bold italic are available with reduced lead times due to our advanced manufacturing process.

Custom sheaves are available. See page 287 for ordering details.

# McKissick® Tapered Bearing Sheaves

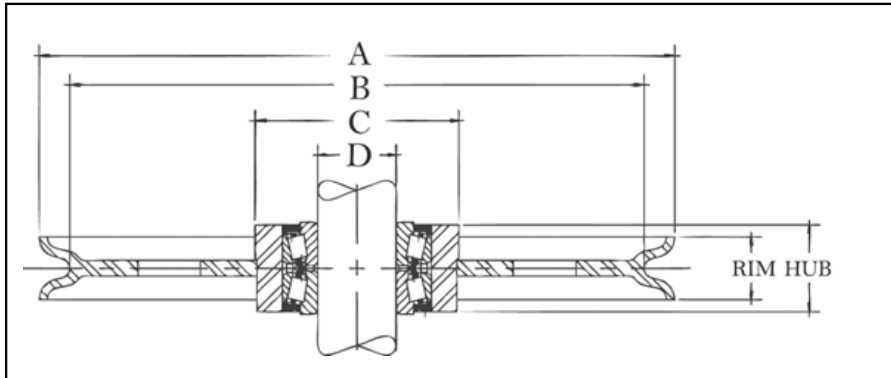

## Tapered Bearing Sheaves

- Roll-Forged sheaves are available in sizes up to 78" in diameter.
- Tapered Bearing Sheaves are designed to operate on shafts machined to +/- .0005 of the indicated shaft size.
- Applications should provide for tightening separator plates against bearing cones to adjust and insure proper function of bearing.
- For sizes not listed, McKissick® Finished Bore Sheaves can be equipped with tapered bearing at an optional charge.

"A" Nominal Outside Diameter (in)	Stock Number	Wire Line Size (in)	"D" Shaft Size (in)	Hub Width (in)	Rim Width (in)	"C" Nominal Hub Outside Diameter (in)	"B" Nominal Tread Diameter (in)	Material	Approx. Weight (lb)
4-7/8	480269	3/8	.749	1-3/8	1-1/8	2-1/4	4-1/16	F.S.	3.60
7	480777	1/4	.749	1-3/8	3/4	2-3/8	6-1/4	B.S.	9.00
8	481017	1/2	.749	1-3/8	1-1/4	2-7/16	6-5/8	F.S.	7.00
8-1/2	481044	3/8	.749	1-3/8	1	2-3/4	7-1/2	D.I.	7.50
9-3/4	481295	3/8	1.499	2-5/16	1	3-3/4	8-3/4	F.S.	11.20
11-7/8	481552	1/4	1.499	2-5/16	1	3-3/4	10-3/4	D.I.	12.0
<b>12</b>	<b>481455</b>	<b>3/4</b>	<b>1.499</b>	<b>2-5/16</b>	<b>2-3/16</b>	<b>4-1/2</b>	<b>9-3/4</b>	<b>R.F.</b>	<b>24.0</b>
<b>12</b>	<b>481446</b>	<b>7/8</b>	<b>1.499</b>	<b>2-5/16</b>	<b>2-3/16</b>	<b>4-1/2</b>	<b>10-1/4</b>	<b>R.F.</b>	<b>24.0</b>
<b>16</b>	<b>4302793</b>	<b>1/2</b>	<b>1.998</b>	<b>2-15/16</b>	<b>2-1/2</b>	<b>5-3/4</b>	<b>14-1/4</b>	<b>R.F.</b>	<b>50.0</b>
<b>16</b>	<b>4300599</b>	<b>3/4</b>	<b>1.998</b>	<b>2-15/16</b>	<b>2-1/2</b>	<b>5-3/4</b>	<b>13-3/8</b>	<b>R.F.</b>	<b>55.0</b>
<b>16</b>	<b>4300018</b>	<b>7/8</b>	<b>1.499</b>	<b>2-5/16</b>	<b>2-3/16</b>	<b>4-1/2</b>	<b>12-15/16</b>	<b>R.F.</b>	<b>37.0</b>
<b>16</b>	<b>4300054</b>	<b>1</b>	<b>1.998</b>	<b>2-15/16</b>	<b>2-1/2</b>	<b>5-3/4</b>	<b>13-3/8</b>	<b>R.F.</b>	<b>42.0</b>
<b>18</b>	<b>4300081</b>	<b>3/4</b>	<b>1.998</b>	<b>2-15/16</b>	<b>2-3/16</b>	<b>6-1/2</b>	<b>16</b>	<b>R.F.</b>	<b>40.0</b>
<b>20</b>	<b>*4302524</b>	<b>5/16</b>	<b>1.998</b>	<b>2-15/16</b>	<b>1-3/8</b>	<b>5-3/4</b>	<b>18-7/8</b>	<b>R.F.</b>	<b>54.0</b>
<b>20</b>	<b>4300161</b>	<b>3/4</b>	<b>1.998</b>	<b>2-15/16</b>	<b>2-1/8</b>	<b>6-1/2</b>	<b>18</b>	<b>R.F.</b>	<b>87.0</b>
<b>20</b>	<b>4300189</b>	<b>1</b>	<b>1.998</b>	<b>2-15/16</b>	<b>2-1/8</b>	<b>6-1/2</b>	<b>16-1/2</b>	<b>R.F.</b>	<b>84.0</b>
<b>24</b>	<b>4301721</b>	<b>9/16</b>	<b>4.248</b>	<b>3-1/2</b>	<b>3-1/8</b>	<b>8</b>	<b>22</b>	<b>R.F.</b>	<b>125</b>
<b>24</b>	<b>*4302720</b>	<b>5/8</b>	<b>2.755</b>	<b>2-15/16</b>	<b>1-1/2</b>	<b>6-1/2</b>	<b>21-3/4</b>	<b>R.F.</b>	<b>136</b>
<b>24</b>	<b>4300312</b>	<b>7/8</b>	<b>4.248</b>	<b>3-1/2</b>	<b>3-1/8</b>	<b>8</b>	<b>20-7/8</b>	<b>R.F.</b>	<b>125</b>
<b>24</b>	<b>4300321</b>	<b>1</b>	<b>4.248</b>	<b>3-1/2</b>	<b>3-1/8</b>	<b>7-5/8</b>	<b>21-1/8</b>	<b>R.F.</b>	<b>125</b>
<b>24</b>	<b>4300401</b>	<b>1-1/8</b>	<b>2.755</b>	<b>2-15/16</b>	<b>2-3/4</b>	<b>6-1/2</b>	<b>20-1/16</b>	<b>R.F.</b>	<b>80.0</b>
<b>24</b>	<b>4300330</b>	<b>1-1/8</b>	<b>4.248</b>	<b>3-1/2</b>	<b>3-1/8</b>	<b>8</b>	<b>20-1/16</b>	<b>R.F.</b>	<b>125</b>
<b>24</b>	<b>4300269</b>	<b>1-1/2</b>	<b>4.248</b>	<b>3-1/2</b>	<b>3-1/8</b>	<b>8-1/4</b>	<b>20</b>	<b>R.F.</b>	<b>125</b>
<b>30</b>	<b>4300483</b>	<b>7/8</b>	<b>4.248</b>	<b>3-1/2</b>	<b>3-1/8</b>	<b>8</b>	<b>27</b>	<b>R.F.</b>	<b>140</b>
<b>30</b>	<b>4300492</b>	<b>1</b>	<b>4.248</b>	<b>3-1/2</b>	<b>3-1/8</b>	<b>7-5/8</b>	<b>26.5</b>	<b>R.F.</b>	<b>210</b>
<b>30</b>	<b>4300526</b>	<b>1</b>	<b>5.624</b>	<b>3-11/16</b>	<b>3-1/8</b>	<b>9-1/2</b>	<b>27</b>	<b>R.F.</b>	<b>190</b>
<b>30</b>	<b>4300508</b>	<b>1-1/8</b>	<b>4.248</b>	<b>3-1/2</b>	<b>3-1/8</b>	<b>8</b>	<b>27</b>	<b>R.F.</b>	<b>140</b>
<b>30</b>	<b>4300535</b>	<b>1-1/8</b>	<b>5.624</b>	<b>3-11/16</b>	<b>3-1/8</b>	<b>9-1/2</b>	<b>26-3/8</b>	<b>R.F.</b>	<b>140</b>
<b>30</b>	<b>4300704</b>	<b>1-1/4</b>	<b>5.624</b>	<b>3-11/16</b>	<b>3-1/8</b>	<b>9-1/2</b>	<b>26-3/8</b>	<b>R.F.</b>	<b>140</b>

\* Without Flame Harden groove.

Material: B.S.=Bar Steel, C.I.=Cast Iron, F.S.=Forged Steel, D.I.=Ductile Iron, C.S.=Cast Steel, P.M.=Powdered Metal, R.F.=Roll-Forged.

McKissick® Roll-Forged sheaves highlighted above in bold italic are available with reduced lead times due to our advanced manufacturing process.

Custom sheaves are available. See page 287 for ordering details.



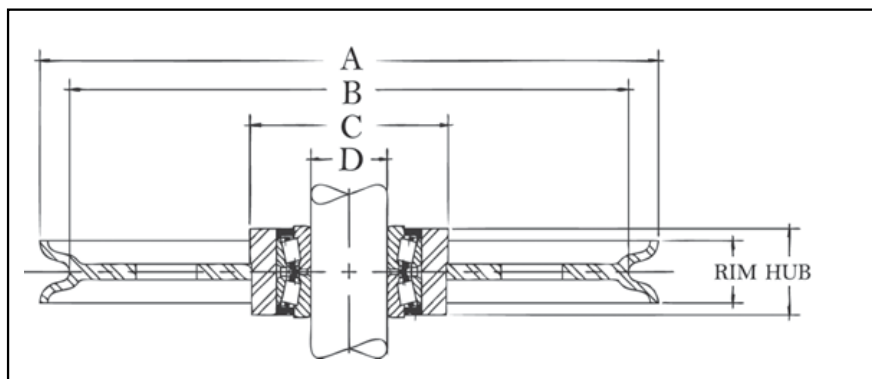

## Plain Bore Oilfield Sheave

McKissick® Roll-Forged Sheaves are available in many configurations in order to meet various oilfield applications

- Roll-Forged sheaves are available in sizes up to 78" in diameter.
- Applications should provide for tightening separator plates against bearing cones to adjust and insure proper function of bearing.
- Each sheave in the table below has a machined bore sized to accept the respective bearing number shown.
- The sheaves are provided from the factory plain bore (the bearings are not included).

"A" Nominal Outside Diameter (in)	Stock Number	Wire Line Size (in)	Bore Information			Hub Width (in)	Rim Width (in)	"C" Nominal Hub Outside Diameter (in)	"B" Nominal Tread Diameter (in)	Material	Approx. Weight (lb)
			"D" Bore Size (in)	Bearing Info. (Bearing not Included)							
				Shaft Size (in)	Bearing or Equivalent Description						
<b>20" Sheave</b>											
20	2030311	9/16	4.722	2.756	NA-483-SW-472-D	2.750	2.750	6.500	17.62	R.F.	80
20	2029285	5/8	4.722	2.756	NA-483-SW-472-D	2.750	2.750	6.500	17.81	R.F.	75
<b>24" Sheave</b>											
24	2030941	9/16	6.498	4.250	NA56425-SW-56650D	3.375	3.125	8.00	21.62	R.F.	103
24	2030905	5/8	6.498	4.250	NA56425-SW-56650D	3.375	3.000	8.00	22.00	R.F.	117
24	2026108	7/8	6.498	4.250	NA56425-SW-56650D	3.375	3.125	8.00	20.94	R.F.	128
24	2025931	1	6.498	4.250	NA56425-SW-56650D	3.375	3.125	9.00	21.12	R.F.	125
<b>24" Crown Sheave**</b>											
24	2027885	9/16	6.498	4.250	NA56425-SW-56650D	3.375	3.125	8.00	21.62	R.F.	90
24	2027887	5/8	6.498	4.250	NA56425-SW-56650D	3.375	2.750	8.00	22.00	R.F.	80
24	2027880	7/8	6.498	4.250	NA56425-SW-56650D	3.375	3.125	8.00	20.94	R.F.	125
24	2023993	1	6.498	4.250	NA56425-SW-56650D	3.375	3.125	9.00	21.12	R.F.	110
<b>30" Sheave</b>											
30	2026299	1	6.498	4.250	NA56425-SW-56650D	3.375	3.125	8.50	26.50	R.F.	190
30	2026036	1-1/8	6.498	4.250	NA56425-SW-56650D	3.375	3.125	9.00	26.06	R.F.	230
30	2026230	1	7.873	5.625	NA48685-SW/48620	3.500	3.125	10.25	26.50	R.F.	255
30	2026003	1-1/8	7.873	5.625	NA48685-SW/48620	3.500	3.125	10.25	26.06	R.F.	255
30	2030906	1	8.873	6.500	NA46790-SW-46720	3.625	3.375	10.25	26.50	R.F.	185
30	2030907	1-1/8	8.873	6.500	NA46790-SW-46720	3.625	3.375	12.00	26.06	R.F.	265
<b>30" Crown Sheave**</b>											
30	2027941	1	6.498	4.250	NA56425-SW-56650D	3.375	3.125	9.00	26.50	R.F.	150
30	2027945	1-1/8	6.498	4.250	NA56425-SW-56650D	3.375	3.125	9.00	26.06	R.F.	200
30	2030274	1	7.873	5.625	NA48685-SW/48620	3.500	3.125	10.25	26.50	R.F.	161
30	2030260	1-1/8	7.873	5.625	NA48685-SW/48620	3.500	3.125	10.25	26.06	R.F.	218
<b>36" Sheave</b>											
36	2030942	1	7.873	5.625	NA48685-SW/48620	3.500	3.250	10.250	33.12	R.F.	350
36	2030908	1-1/8	7.873	5.625	NA48685-SW/48620	3.500	3.250	10.250	33.62	R.F.	350
36	2027967	1-1/4	7.873	5.625	NA48685-SW/48620	3.500	3.250	12.00	32.25	R.F.	320
36	2030943	1	8.873	6.500	NA46790-SW-46720	3.625	3.125	11.50	33.12	R.F.	353
36	2029390	1-1/8	8.873	6.500	NA46790-SW-46720	3.625	3.250	11.00	32.62	R.F.	300
36	2029392	1-1/4	8.873	6.500	NA46790-SW-46720	3.625	3.250	11.00	32.25	R.F.	300
36	2030944	1	10.873	8.000	LM241149NW/241110-D	3.625	3.125	14.00	33.12	R.F.	370
36	2030909	1-1/8	10.873	8.000	LM241149NW/241110-D	3.625	3.500	14.00	32.06	R.F.	358
36	2030945	1-1/4	10.873	8.000	LM241149NW/241110-D	3.625	3.375	14.00	32.25	R.F.	330
<b>36" Crown Sheave**</b>											
36	2030282	1	7.873	5.625	NA48685-SW/48620	3.50	3.25	10.25	33.12	R.F.	240
36	2030284	1 1/8	7.873	5.625	NA48685-SW/48620	3.50	3.25	10.25	32.62	R.F.	250

\*\* Crown Sheaves contain lightening holes.

Custom sheaves are available. See page 287 for ordering details.

# McKissick® Standard API 8C Oilfield Sheaves

"A" Nominal Outside Diameter (in)	Stock Number	Wire Line Size (in)	Bore Information			Hub Width (in)	Rim Width (in)	"C" Nominal Hub Outside Diameter (in)	"B" Nominal Tread Diameter (in)	Material	Approx. Weight (lb)
			"D" Bore Size (in)	Bearing Info. (Bearing not Included)							
				Shaft Size (in)	Bearing or Equivalent Description						
<b>42" Sheave</b>											
42	2030949	1-1/4	10.873	8.000	LM241149NW/241110-D	3.625	3.250	14.00	38.25	R.F.	460
42	2030950	1-1/8	12.873	9.250	NA8575SW-8520CD	4.500	3.500	16.00	38.62	R.F.	465
42	2030951	1-1/4	12.873	9.250	NA8575SW-8520CD	4.500	3.375	16.00	38.25	R.F.	475
<b>44" Sheave</b>											
44	2030952	1-1/8	10.873	8.000	LM241149NW/241110-D	3.625	3.375	14.00	40.06	R.F.	615
44	2030953	1-1/4	10.873	8.000	LM241149NW/241110-D	3.625	3.000	14.00	40.25	R.F.	545
<b>48" Sheave</b>											
48	2030954	1-1/8	10.873	8.000	LM241149NW/241110-D	3.625	3.250	14.00	44.62	R.F.	580
48	2030955	1-1/4	10.873	8.000	LM241149NW/241110-D	3.625	2.750	14.00	44.25	R.F.	512
48	2030956	1-1/4	13.686	9.999	LM249747NW/LM249710D	3.875	3.250	17.00	44.25	R.F.	640
<b>50" Sheave</b>											
50	2030938	1-1/4	10.873	8.000	LM241149NW/241110-D	3.625	3.375	14.00	46.25	R.F.	765
50	2030957	1-1/4	13.686	8.000	LM241149NW/241110-D	3.875	3.250	17.00	46.25	R.F.	765
50	2030958	1-3/8	13.686	9.999	LM249747NW/ LM249710D	3.875	3.750	17.00	45.62	R.F.	735
<b>55" Sheave</b>											
55	2030959	1-1/8	12.873	9.250	NA8575SW-8520CD	4.500	3.500	16.00	51.06	R.F.	890
55	2030960	1-1/4	12.873	9.250	NA8575SW-8520CD	4.500	3.375	16.00	51.25	R.F.	825
55	2030961	1-1/4	13.686	9.999	LM249747NW/ LM249710D	3.875	3.500	19.00	51.25	R.F.	588
<b>60" Sheave</b>											
60	2030879	1-1/4	13.686	9.999	LM249747NW/ LM249710D	3.875	3.25	17.00	56.25	R.F.	1095
60	2030880	1-3/8	13.873	10.500	LM251649NW/251610-D	4.125	3.625	19.00	55.88	R.F.	1175
60	2030881	1-3/8	15.498	12.000	L357049NW/L357010D	4.125	3.75	19.00	55.88	R.F.	1175
60	2030875	1-1/2	13.686	9.999	LM249747NW/ LM249710D	3.875	3.50	19.00	55.50	R.F.	1175
60	2030872	1-1/2	13.873	10.500	LM251649NW/251610-D	4.125	3.625	19.00	55.50	R.F.	1175
60	2030876	1-1/2	15.498	12.000	L357049NW/L357010D	4.125	3.50	19.00	55.50	R.F.	1165
60	2030877	1-5/8	15.498	12.000	L357049NW/L357010D	4.125	3.50	19.00	55.12	R.F.	1150

Custom sheaves are available. See page 287 for ordering details.

**McKissick® manufactures special Roll-Forged Sheaves to meet the Specifications of AISE Standard Number 6.**

- AISE Sheaves must meet specified criteria established by the Association of Iron and Steel Engineers for special use in electric overhead Traveling Cranes for Steel Mill Service.
- Other typical applications that may specify AISE sheaves:
  - Mobile Cranes
  - Portal Cranes
  - Power Shovels
  - Other equipment using Wirelinee

**Typical AISE Sheave Rim Profile with Specified Dimensional Requirements**

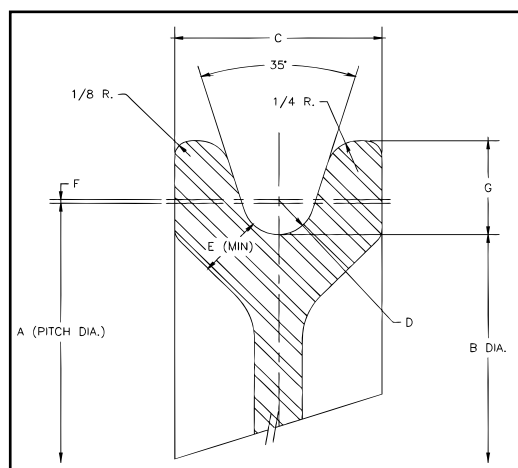

Sheave Wheel Contours							
Rope Diameter* (in)	Dimensions (in)						
	A	B	C	D	E	F	G
1/2	15	14-1/2	1-3/4	9/32	1/2	1/32	3/4
5/8	18-3/4	18-1/8	2	11/32	5/8	1/32	15/16
3/4	22-1/2	21-3/4	2-1/4	13/32	3/4	1/32	1-1/8
7/8	26-1/4	25-3/8	2-1/2	31/64	7/8	3/64	1-5/16
1	30	29	2-3/4	35/64	1	3/64	1-1/2
1-1/8	33-3/4	32-5/8	3	39/64	1-1/8	3/64	1-11/16
1-1/4	37-1/2	36-1/4	3-1/4	11/16	1-1/4	1/16	1-7/8
1-3/8	41-1/4	39-7/8	3-1/2	3/4	1-3/8	1/16	2-1/16
1-1/2	45	43-1/2	3-3/4	13/16	1-1/2	1/16	2-1/4

\* Sheaves with other Wireline sizes are available upon request. Other pitch diameters available on application basis. Grooves are flame hardened to min. RC35 for 1/2" Wireline and larger.

**For additional information concerning special AISE sheaves, contact:**

**In U.S.A.** - Crosby's Special Engineered Product Group at 1-800-777-1555

**In Canada** - Crosby Canada at (877) 462-7672

**In Europe** - N.V. Crosby Europe at (+32) (0)15 75 71 25

# McKissick® European Style 45° Metric Sheaves

## Selecting your Sheave O.D. / Wireline Size Combinations

To ease the effort in choosing the proper standard McKissick® Roll-Forged sheave required for your application, we have simplified our product offering. The table below indicates the standard Sheave O.D. / Wireline sizes that are available.

## How to Read the Table

- Cells outlined in RED represent the standard O.D. / Wireline combinations available with the Sheave Configurator program.

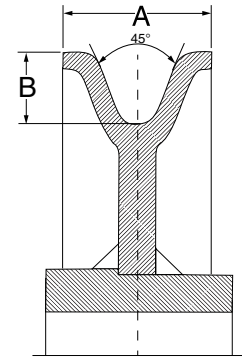

## Sheave O.D. / Wireline Information

Wireline Size (mm)	Nominal Dimensions (mm)		Groove Radius (mm)		Sheave O.D. (mm)														
	A	B	MIN	MAX	280	300	320	350	400	450	500	520	550	600	630	650	700	800	
11	40	19	5.83	6.05															
12	40	18	6.36	6.60															
13	40	18	6.89	7.15															
11	40	19.5	5.38	6.05															
12	40	20.5	6.36	6.60															
13	40	19.5	6.89	7.15															
14	40	21	7.42	7.70															
15	40	21	7.95	8.25															
16	45	25	8.48	8.80															
17	45	25	9.01	9.35															
13	40	23	6.89	7.15															
14	40	22	7.42	7.70															
15	40	22	7.95	8.25															
15	45	25	7.95	8.25															
16	45	24	8.48	8.80															
17	45	24	9.01	9.35															
15	45	26	7.95	8.25															
16	45	25	8.48	8.80															
17	50	28	9.01	9.35															
18	50	27	9.54	9.90															
19	55	28.5	10.07	10.45															
20	55	25.5	10.60	11.00															
21	60	34	11.13	11.55															
22	60	33	11.66	12.10															
23	60	33	12.19	12.65															
19	55	31	10.07	10.45															
20	55	30	10.60	11.00															
21	55	30	11.13	11.55															
21	60	34	11.13	11.55															
22	60	33	11.66	12.10															
23	60	33	12.19	12.65															
21	60	34	11.13	11.55															
22	60	33	11.66	12.10															
23	60	33	12.19	12.65															
23	65	37	12.19	12.65															
24	65	36	12.72	13.20															
25	65	36	13.25	13.75															
26	70	39	13.78	14.30															
27	70	39	14.31	14.85															
23	65	37	12.19	12.65															
24	65	36	12.72	13.20															
25	65	36	13.25	13.75															
26	70	39	13.78	14.30															
27	75	43	14.31	14.85															
28	75	42	14.84	15.40															
29	75	42	15.37	15.95															
27	75	43	14.31	14.85															
28	75	43	14.84	15.40															
29	75	42	15.37	15.95															
28	80	47	14.84	15.40															
29	80	46	15.37	15.95															
30	80	45	15.90	16.50															
32	80	45	16.96	17.60															
30	90	50	15.90	16.50															
32	90	48	16.96	17.60															
34	90	48	18.02	18.70															
34	100	56	18.02	18.70															
36	100	54	19.08	19.80															
38	100	54	20.14	20.90															

McKissick Sheaves



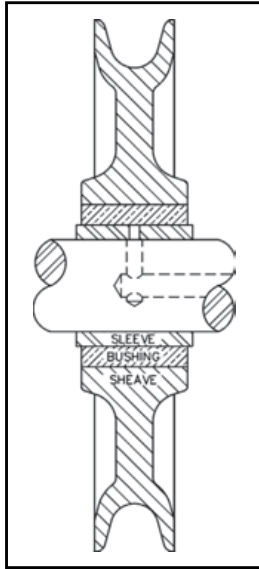

## IRON SHEAVES FOR USE WITH MANILA ROPE BLOCKS

- 1101 – 1141  
Common Iron Bushed
- 1102 – 1142  
Roller Bushed
- 1103 – 1143  
Bronze Bushed, Self-Lubricating

## FOR REGULAR MANILA ROPE BLOCKS – OLD STYLE

Block Size	Stock No.			Manila Rope Size (in)	Sheave Size (in)			Weight Each (lb)
	1101 Galv.	1102 Galv.	1103 Galv.		Outside Dia. (A)	Rim Width (B)	Bore Size (C)	
3	900010	900216	900412	3/8	1-3/4	1/2	3/8	.25
4	900038	900234	900430	1/2	2-1/4	5/8	3/8	.75
5	900056	900252	900458	5/8	3	3/4	3/8	.50
6	900074	900270	900476	3/4	3-1/2	1	1/2	1.00
7	900092	900298	900494	7/8	4-1/4	1	1/2	1.25
8	900118	900314	900519	1	4-3/4	1-1/8	5/8	1.75

## FOR REGULAR MANILA ROPE BLOCKS – NEW STYLE

Block Size	Stock No.	Manila Rope Size (in)	Sheave Size (in)			Sleeve Diameter (in)		Weight Each (lb)
	Bronze Bushed		Outside Dia.	Rim Width	Bearing Diam. (C)	I.D. (F)	O.D. (E)	
4	2028373	1/2	2-1/4	5/8	5/8	3/8	5/8	.75
6	2028375	3/4	3-1/2	1	3/4	1/2	3/4	1.00
8	2028376	1	4-3/4	1-1/8	7/8	5/8	7/8	1.75

## FOR MANILA ROPE SNATCH BLOCKS – OLD STYLE

Block Size	Stock No.			Manila Rope Size (in)	Sheave Size (in)			Sleeve Diameter (in)		Weight Each (lb)
	1141 Galv.	1142 Galv.	1143 Galv.		Outside Dia.	Rim Width	Bearing Diam. (C)	I.D. (F)	O.D. (E)	
6	902018	902214	902410	3/4	3	1-1/8	3/4	1/2	3/4	1.00
7	902036	902232	902438	7/8	3-1/2	1-1/4	3/4	1/2	3/4	2.00
8	902054	902250	902456	1	4-1/2	1-3/8	7/8	5/8	7/8	3.00
10	902072	902278	902474	1-1/4	5-3/4	1-7/8	1	3/4	1	7.00
12	902090	902296	902492	1-1/2	6-3/4	2-1/8	1	3/4	1	12.0

## FOR MANILA ROPE SNATCH BLOCKS – NEW STYLE

Block Size	Stock No.			Manila Rope Size (in)	Sheave Size (in)			Sleeve Diameter (in)		Weight Each (lb)
	Bronze Bushed Red	Bronze Bushed Galv.			Outside Dia.	Rim Width	Bearing Diam. (C)	I.D. (F)	O.D. (E)	
6	2027020	2027021		3/4	3	7/8	3/4	-	-	1.30
8	2028971	2027015		1	4-1/8	1-3/8	1	-	-	3.74
10	2028972	2026507		1-1/4	6	1-5/8	1-1/2	-	-	10.00
12	2028973	2026509		1-1/2	8	1-5/8	1-1/2	-	-	12.00

## FOR MANILA AND WIRE ROPE SNATCH BLOCKS – OLD STYLE

- 1298 - Bronzed Brushed, Self-Lubricating Steel sheave for Wire Rope.
- 1192 - Bronzed Brushed, Self-Lubricating Iron sheave for Wire Rope.
- 1293 - Bronzed Brushed, Self-Lubricating Steel sheave for Manila Rope.

Snatch Block		Stock No.			1192 Wire Line Size	1293 Painted Stock No.	1293 Manila Rope Size	Sheave Size (in)				Bushing I.D.	Sleeve Dimensions (in)			Weight Each (lb)		
Style	Shell Length	1298 Painted	1192 Painted	Outside Dia.				Hub Width	Rim Width	Bore Size	I.D.		O.D.	Length	1298	1192	1293	
924	-	922005	-	5/8	-	-	6	1-3/8	1-1/4	1-5/8	1-1/4	1	1-1/4	1-1/2	6.00	-	-	
924	-	922023	-	3/4	-	-	8	1-5/8	1-1/2	1-7/8	1-1/2	1-1/4	1-1/2	1-3/4	11.0	-	-	
924	-	922041	-	7/8	-	-	10	1-5/8	1-1/2	2-1/2	2	1-1/2	2	1-3/4	19.0	-	-	
<b>924</b>	-	<b>922069</b>	-	<b>7/8</b>	-	-	<b>12</b>	<b>2</b>	<b>1-3/4</b>	<b>2-1/2</b>	<b>2</b>	<b>1-1/2</b>	<b>2</b>	<b>2-1/8</b>	<b>22.0</b>	-	-	
940-941	-	922078	920579	3/8	-	-	4	13/16	3/4	1-1/8	3/4	1/2	3/4	7/8	3.00	2.00	-	
940-941	-	922087	920588	1/2	-	-	6	1-1/16	1	1-3/8	1	3/4	1	1-1/8	7.00	3.84	-	
940-941	-	922103	920604	5/8	-	-	8	1-3/8	1-1/4	1-1/2	1-1/8	7/8	1-1/8	1-1/2	8.00	9.90	-	
940-941	-	922121	920622	5/8	-	-	10	1-3/8	1-1/4	1-5/8	1-1/4	1	1-1/4	1-1/2	12.0	17.0	-	
940-941	-	922149	920640	3/4	-	-	12	1-5/8	1-1/2	1-7/8	1-1/2	1-1/4	1-1/2	1-3/4	39.0	32.0	-	
1096	6	-	-	-	921505	7/8	3	1-3/16	1-1/8	1-3/8	1	5/8	1-1/4	1-1/2	-	-	2.00	
1096	8	-	-	-	921523	1	4-1/2	1-7/16	1-3/8	1-5/8	1-1/4	7/8	1-1/4	1-1/2	-	-	6.00	
961	-	922407	-	5/8	-	-	6	1-5/8	1-1/2	2	1-5/8	1-1/4	1-5/8	1-3/4	9.00	-	-	
961	-	922425	-	7/8	-	-	8	1-11/16	1-1/2	2-1/2	2	-	-	-	15.0	-	-	

Sheaves highlighted above in bold italic are available with reduced lead times due to our advanced manufacturing process.



# McKISSICK BLOCKS

With Product Warnings and Application Information





418

**McKISSICK®**  
**LEBUS**

**"There is No Equal"**

The Market Leader: Yesterday Today and Tomorrow



L-170

## McKissick Blocks

### DESIGN

The theoretical reserve capability of a snatch block should be at least 4:1. Known as the DESIGN FACTOR, it is usually computed by dividing the ultimate load by the working load limit. The ultimate load is the average load or force at which the block fails or no longer supports the load. The working load limit is the maximum mass or force which the product is authorized to support in general service. The design factor is generally expressed as a ratio such as 4:1. Also important in the design of snatch blocks is the selection of proper steel used in components and consideration as to fatigue life.

### THE COMPETITION

- ASK:** Are their snatch blocks metric rated?
- ASK:** What is the metric design factor?
- ASK:** Are their snatch blocks fatigue rated?

Most do not provide metric ratings with a design factor of 4:1, nor fatigue rated snatch blocks.

**Crosby®**

McKissick and Lebus snatch blocks are dual rated with a design factor of 4:1 for metric and 4.5 to 1 in short tons. McKissick and Lebus snatch blocks incorporate the proper selection of steel and are also fatigue rated.

**Fatigue Rated®**

### END FITTING CONNECTIONS

Interchangeability of end fittings is important, and should be easily achieved without disassembly of the block. It is also important that end fittings are quenched and tempered in order to reduce the risk of brittle, catastrophic failure.

### THE COMPETITION

- ASK:** Are the end fittings forged, quenched and tempered?
- ASK:** Are the end fittings interchangeable?

**Crosby®**

McKissick and Lebus snatch blocks use genuine Crosby forged, quenched and tempered hooks and shackles.



### BLOCK CONSTRUCTION

The block performance depends greatly on the sheave and block construction. All steel construction, including side plates, pins, and sheaves, is desirable. Bronze bushings are recommended for slow line speeds and frequent use. Roller bearings are recommended for faster line speeds and more frequent use at greater loads. The ability to individually lubricate all sheaves is essential. Secondary securement of bolt connecting the end fitting to the block is recommended.

### ASK THE COMPETITION

- ASK:** Are their blocks all steel construction?
- ASK:** Do their blocks have secondary securement of the pins?
- ASK:** Are all sheaves individually lubricated?

**Crosby®**

McKissick and Lebus snatch blocks are of all steel construction. They also have a secondary end fitting securement system. In addition, sheaves are individually lubricated.

### FULL LINE IDENTIFICATION

The availability of a full range of snatch blocks is essential to insure that the appropriate block is available for a specific application. All snatch blocks must be identified by type, size of block, size of Wireline to be used, working load limit, and the manufacturer's name boldly marked on the product.

### THE COMPETITION

- ASK:** Do they have a full range of snatch blocks?
- ASK:** Are their snatch blocks properly marked with critical information?

Most competitors do not have the full range of snatch blocks that Crosby offers.

**Crosby®**

McKissick and Lebus provide the most complete line of snatch blocks in the industry. All McKissick and Lebus snatch blocks are identified by type, size of block, size of Wireline to be used, working load limit (in both metric and short tons), and the manufacturer's name boldly marked on the product.

### STANDARDS ORGANIZATION

All snatch blocks utilized in the oilfield should be manufactured by a source that is both API Q1 and ISO 9001 certified.

### THE COMPETITION

- ASK:** Are they API Q1 certified?
- ASK:** Are they ISO 9001 certified?

Most competitors are not API Q1 certified or ISO 9001 certified.

**Crosby®**

Crosby's McKissick plant is API Q1 certified. McKissick is also certified to ISO 9001 standards by Det Norsk Veritas (DNV).

### APPLICATION INFORMATION

Detailed application information will assist you in the proper selection of snatch blocks. This information is most effective when provided at the point of application, as well as in supporting brochures and engineering information. A formal application and warning system that attracts the attention of the user, clearly informs the user of the factors involved in the task, and informs the user with the proper application procedures is needed.

### THE COMPETITION

- ASK:** Does each snatch block have the application and warning information attached to it?

Most competitors do not have application and warning information with each snatch block.

**Crosby®**

Crosby provides detailed application and warning information attached to each snatch block.

**Remember: "When buying Crosby, you're buying more than product, you're buying Quality."**

- **Dual Rated:** To meet the requirements of both short tons and metric tons.
- **Metric Rating:** McKissick® and Lebus® snatch blocks are metric rated to a design factor of 4:1. Since they are metric rated, with a world class design, they are applicable to worldwide use without conversion.
- **U.S. Rating:** When compared to other blocks which are rated in short tons, the design factor of McKissick® and Lebus® snatch blocks is 4.5 to 1.
- **Fatigue Properties:** McKissick® and Lebus® snatch blocks are fatigue rated. The blocks are designed to meet specific fatigue performance levels. They meet the requirements for the new Euronorm Standards: 20,000 cycles at 1-1/2 times the Working Load Limit.
- **Latch Kits:** McKissick® and Lebus® snatch blocks, utilizing a hook as an end fitting connection, can be equipped with latches.
- **Application Information:** Application and warning information for tackle block systems is attached directly to each block. In addition, each block has a product warning sticker attached directly to it for the purpose of giving specific warning instructions about the block.
- **Lock Nut:** McKissick® snatch blocks have a special high performance lock nut on the nonmoveable side plate for securing the sheave pin.
- **Sheave and Wireline:** Sheaves for McKissick® and Lebus® snatch blocks have a machine formed groove.
- **Secondary Securement Systems:** McKissick® and Lebus® snatch blocks are designed to incorporate a secondary securement system which retains the end fitting connection bolt when the block is in the closed position. In addition, a patented system retains the end fitting connection bolt when the block is in the open position, thus eliminating the loss of block parts.
- **RFID Equipped:** All snatch blocks with sheave diameters of 4-1/2" and larger are equipped with RFID chips to provide a streamlined and automated approach to the inspection process.

**404****TAIL BOARD****418****WITH HOOK****419****WITH SHACKLE**



## BLOCKS

### THE FOLLOWING INFORMATION SHOULD BE SPECIFIED:

1. Stock number (if known)
2. Sheave Size
3. Block Number (Catalog number)
4. Number of Sheaves
5. Type of Bearings: (BB) Bronze Bushed, (RB) Roller, (TB) Tapered Roller
6. Type of Hook or Shackle
7. Wireline Diameter

All crane and some construction blocks are available as shown or with swivel shackle assembly, duplex swivel hook assembly or quadruple hook assembly (as illustrated on page 309). Various combinations of bearing assemblies can be furnished; such as bronze bushed sheaves and swivel hooks, roller or tapered roller bearing sheaves and hook assemblies or a combination of bronze, roller or tapered roller bearings.

### EXAMPLE:

18" 380 Series, Triple Sheave, Roller Bearing Crane Block with Roller Bearing Swivel Hook, 60 ton, light weight, 1" Wireline diameter.  
Model Number M60T18L, Stock Number 2012187

## SHEAVES

### THE FOLLOWING INFORMATION SHOULD BE SPECIFIED:

1. Stock number (if known)
2. Sheave O.D.
3. Bearing Type or Plain Bore
4. Shaft or Bore Size
5. Hub Width
6. Rim Width
7. Wireline Size
8. Special Machine Features
9. Special Finishes

If hub or rim dimensions necessitate a dimension other than those shown in this catalog, please contact The Crosby Group for minimums and maximums. Tapered roller bearing sheaves show width over bearing cones, which cannot be altered.

Price and delivery for your special needs, if not shown, are available upon request.

#### U.S.A.

Phone (918) 834-4611  
Fax (918) 832-0940  
www.thecrosbygroup.com  
crosbygroup@thecrosbygroup.com

#### CANADA

Phone (877) 462-7672  
Fax (877) 260-5106  
www.thecrosbygroup.com  
sales@crosby.ca

#### EUROPE

Phone (+32) (0)15 75 71 25  
Fax (+32) (0)15 75 37 64  
www.thecrosbygroup.com  
sales@crosbyeurope.com

# Construction and Crane Blocks

SOME OF THE MOST IMPORTANT CONSIDERATIONS IN YOUR BLOCK REQUIREMENTS ARE:

## Available Bearing Types



Bronze Bushed - S.A.E. 660 bronze with figure "8" oil groove



Double Row Sealed Tapered Roller Bearing



Straight Roller Bearing



Full Complement Cylindrical Roller Bearing



Unretouched photograph of a section cut from a flame hardened McKissick sheave (etched 2-1/2 minutes).

## THE SHEAVE

Note the groove form with proper line support and gently rounded lips to prevent line chafing when fleet angles etc. are present

Note the groove is completely machined to proper line size.

Note the dense martensitic structure clearly outlined by the etch. This flame hardened surface in the wear area of the sheave always presents a smooth, uncorrugated, proper size groove face to the line. Sheaves 14" (356mm) diameter and over are flame hardened in groove to minimum 35 Rockwell C. Smaller sheaves can be flame hardened on special order.

McKissick  
Blocks

## ADDITIONAL CONNECTIONS

All Crane and Construction Blocks can be Furnished with:



Swivel shackle in selected capacities, with bronze thrust or roller thrust bearing.

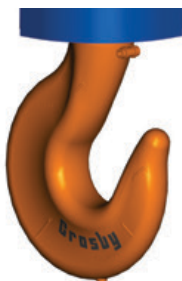

Single hook in capacities to 300 tonnes (See page 453).



Duplex swivel hook in standard capacities to 1,000 tonnes. Larger sizes available (See page 455).

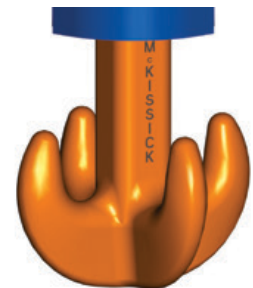

Quad swivel hook from 200 tonnes and larger.

## 380 SERIES HOOK BLOCKS

- Wide range of product available.
  - Capacity: 5 to 300 Tons - Larger Models Available.
  - Sheave Sizes: 10" to 30".
  - Wireline Sizes: 7/16" to 1-3/8".
- Manufactured by an ISO 9001 and API Q1 certified facility .
- All single point shank hooks are genuine Crosby®, forged alloy steel, Quenched and Tempered, and have the patented **QUIC-CHECK®** markings (Duplex hooks are available on all sizes).
- All 380 Blocks are furnished standard with Roller Bearings.
- Reeving Guide Standard – All Models.
- Blocks thru 25 tons use 319N style hooks with S-4320 latches.
- Sheaves lubrication through center pin – separate lube channel to each bearing.
- Sheave fully protected by side plates.
- Dual action hook (swings and rotates).
- Repair parts available through worldwide distribution network.
- Design Factor of 4:1 (unless otherwise noted).
- All 380 blocks 16" and larger are furnished with McKissick® Roll-Forged sheaves with flame hardened grooves
- "Look for the Orange Hook . . . the mark of genuine McKissick® quality".



### OPTIONS AVAILABLE

- Bronze Bushed Sheaves
- Duplex Hooks
- Swivel Tee and Shackle Assemblies
- Sheave Shrouds
- Anti Rotation Hook - Locking Device
- Plate Steel Cheek Weights
- Third party testing with Certification available upon request

### Dead End Chart (Double, Triple, & Quad Sheave Blocks\*)

Wireline Size (in)	Dimensions (in)		Recommended Wedge Socket	
	T Thickness	U Hole Diameter	McKissick® US-422 / US-422T Utility Socket	
			Stock No.	Size
7/16	1.00	1.28	1044309+	US4 7/16
1/2	1.00	1.28	1044318+	US4 1/2
9/16	1.00	1.28	1044336+	US5 9/16
5/8	1.00	1.28	1044345+	US5 5/8
3/4	1.25	1.66	1044363+	US6 3/4
7/8	1.25	1.66	1038580	US7 7/8
1	1.25	1.66	1044417+	US8 1
1-1/8	1.75	2.56	1044426+	US10 1-1/8
1-1/4	1.75	2.56	1044435+	US10 1-1/4

\* To find Dead End Dimensions for Single Sheave blocks, refer to block tables on pages 313  
 + US-422T Terminator Style.



**380**  
Series Hook Block

The patented McKissick Split-Nut® is the standard retention system for standard crane blocks up to 100 Tons.

**For custom orders contact our Block Hotline at:**  
 (800) 727-1555 or refer to the special request form on page 453.

### 381 – SINGLE

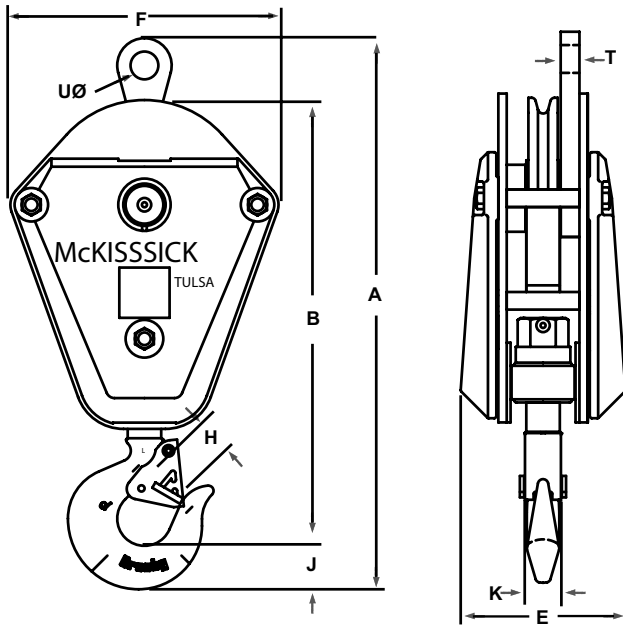

### 382 – DOUBLE

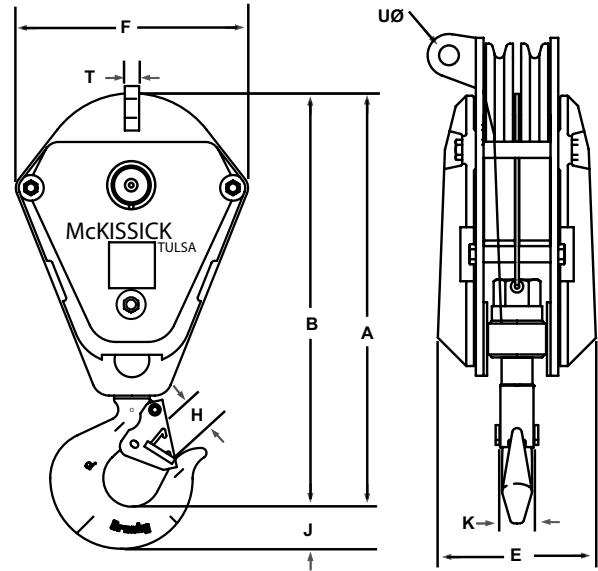

### 383 – TRIPLE

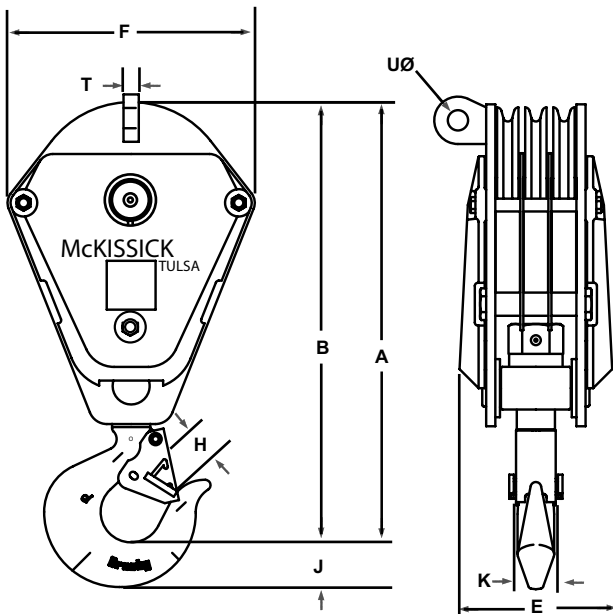

### 384 – QUAD

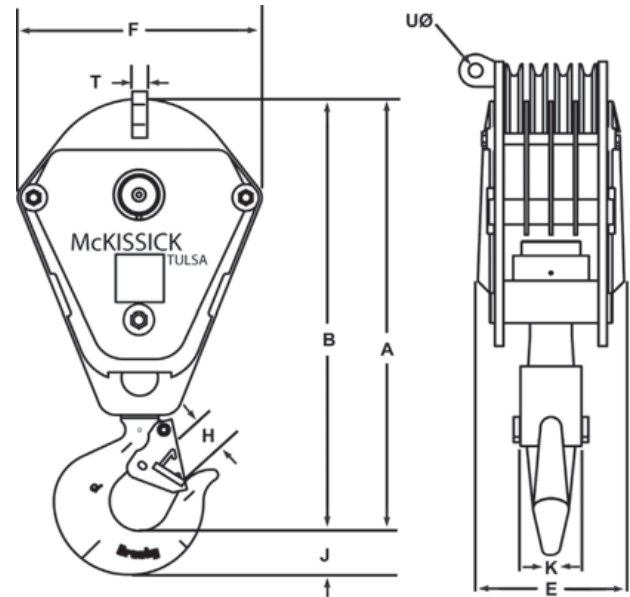

Thickness (E) shown is for blocks containing cheek weights (Light Medium - LM, Medium - M, and Heavy - H).  
The Thickness (E) for non weighted blocks (Light - L) is measured over side plates.



**385 – QUINTUPLE**

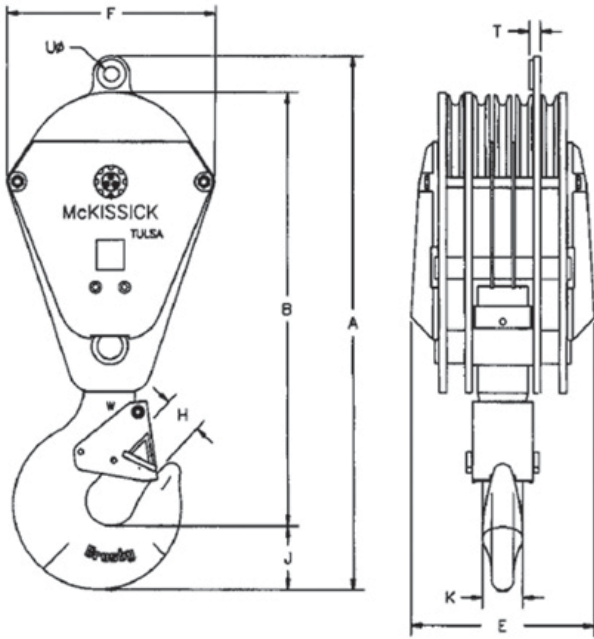

**386 – SEXTUPLE**

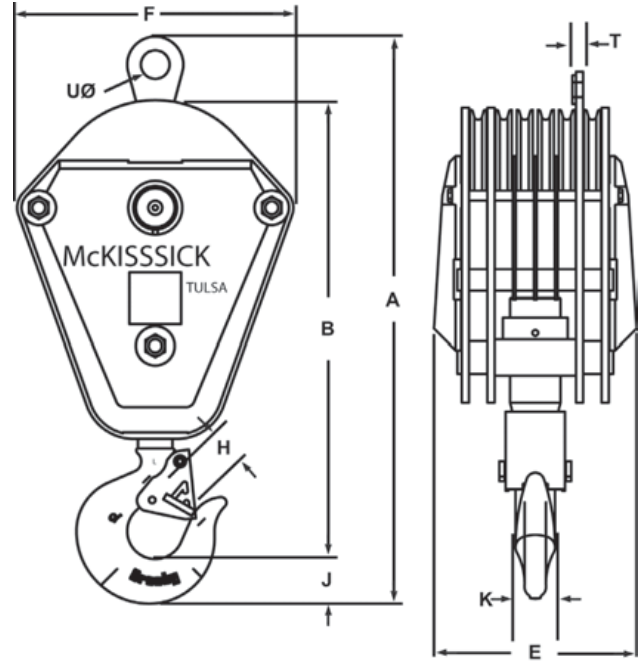

**387 – SEPTUPLE**

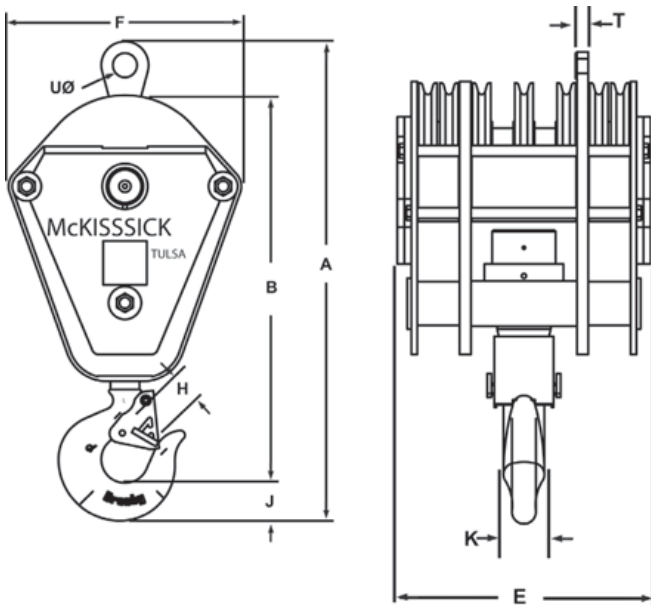

**388 – OCTUPLE**

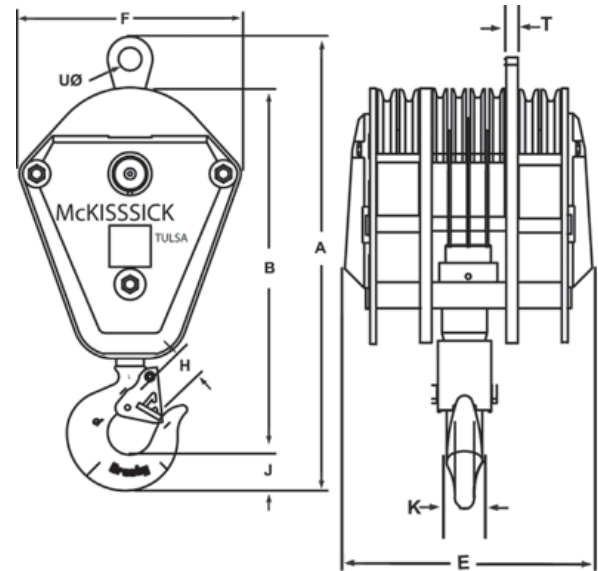

Thickness (E) shown is for blocks containing cheek weights (Light Medium - LM, Medium - M, and Heavy - H).  
The Thickness (E) for non weighted blocks (Light - L) is measured over side plates.

# McKissick® 380 Series Crane Blocks

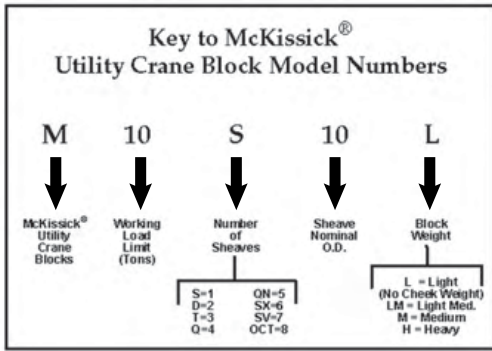

Sheave Diameter (in)	Wireline Size (in)									
	7/16	1/2	9/16	5/8	3/4	7/8	1	1 1/8	1 1/4	1 3/8
10										
12										
14										
16										
18										
20										
24										
30										

\*For additional Wireline sizes, please call Crosby's Special Engineered Products Group at 1(800)777-1555.

## 380 Series Crane Blocks

- Specify Wireline size when ordering. For standard Wireline sizes, see Table 1.
- All sizes are **RFID EQUIPPED**.
- The patented McKissick Split-Nut® is the standard retention system for standard crane blocks up to 100 tons.

Model No.	Inquiry Stock No.	Working Load Limit (Tons) †	A Overall Length (in)	B Net Length (in)	E Thickness (in)	F Width (in)	H Throat Opening with Flapper (in)	J Hook Thickness (in)	K Hook Width (in)	Standard Wireline Sizes (in)*	Dead End ‡		Weight Each (lb)
											T Thickness (in)	U Pin Hole (in)	
<b>5 Tons</b>													
M5S10L	2011004	5	31.03	24.84	5.34	14.00	1.91	2.59	1.94	7/16,1/2,9/16,5/8	1.13	1.41	140
M5S10M	2011013	5	31.03	24.84	8.53	14.00	1.91	2.59	1.94	7/16,1/2,9/16,5/8	1.13	1.41	200
M5S12L	2011022	5	32.88	26.59	5.34	16.00	1.91	2.59	1.94	1/2,9/16,5/8,3/4	1.13	1.41	142
M5S12M	2011031	5	32.88	26.59	9.84	16.00	1.91	2.59	1.94	1/2,9/16,5/8,3/4	1.13	1.41	270
M5S12H	2011036	5	32.88	26.59	13.84	16.00	1.91	2.59	1.94	1/2,9/16,5/8,3/4	1.13	1.41	400
M5D10L	2011037	5	27.44	24.84	5.34	14.00	1.91	2.59	1.94	7/16,1/2,9/16,5/8	-	-	161
M5D10M	2011038	5	27.44	24.84	8.53	14.00	1.91	2.59	1.94	7/16,1/2,9/16,5/8	-	-	223
<b>10 Tons</b>													
M10S10L	2011040	10	31.03	24.84	5.34	14.00	1.91	2.59	1.94	7/16,1/2,9/16,5/8	1.13	1.41	135
M10S10M	2011049	10	31.03	24.84	8.53	14.00	1.91	2.59	1.94	7/16,1/2,9/16,5/8	1.13	1.41	199
M10S12L	2011058	10	32.88	26.59	5.34	14.00	1.91	2.59	1.94	1/2,9/16,5/8,3/4	1.13	1.41	145
M10S12M	2011067	10	32.88	26.59	9.84	14.00	1.91	2.59	1.94	1/2,9/16,5/8,3/4	1.13	1.41	270
M10S12H	2011071	10	32.88	26.59	13.84	14.00	1.91	2.59	1.94	1/2,9/16,5/8,3/4	1.13	1.41	435
M10S14L	2011076	10	35.12	28.84	5.34	18.00	1.91	2.59	1.94	1/2,9/16,5/8,3/4	1.13	1.41	181
M10S14LM	2011085	10	35.12	28.84	7.34	18.00	1.91	2.59	1.94	1/2,9/16,5/8,3/4	1.13	1.41	275
M10S14M	2011094	10	35.12	28.84	10.28	18.00	1.91	2.59	1.94	1/2,9/16,5/8,3/4	1.13	1.41	360
M10S14H	2011097	10	35.12	28.84	14.72	18.00	1.91	2.59	1.94	1/2,9/16,5/8,3/4	1.13	1.41	515
M10S16L	2011098	10	37.38	31.09	5.34	20.25	1.91	2.59	1.94	9/16,5/8,3/4,7/8	1.13	1.41	220
M10S16M	2011099	10	37.38	31.09	9.72	20.25	1.91	2.59	1.94	9/16,5/8,3/4,7/8	1.13	1.41	390
M10S16H	2011100	10	37.38	31.09	12.22	20.25	1.91	2.59	1.94	9/16,5/8,3/4,7/8	1.13	1.41	540
M10D10L	2011103	10	27.44	24.84	5.34	14.00	1.91	2.59	1.94	7/16,1/2,9/16,5/8	-	-	161
M10D10M	2011112	10	27.44	24.84	8.53	14.00	1.91	2.59	1.94	7/16,1/2,9/16,5/8	-	-	220
M10D12L	2011121	10	29.19	26.59	5.34	16.00	1.91	2.59	1.94	1/2,9/16,5/8,3/4	-	-	185
M10D12M	2011130	10	29.19	26.59	9.84	16.00	1.91	2.59	1.94	1/2,9/16,5/8,3/4	-	-	295
M10D12H	2011135	10	29.19	26.59	13.84	16.00	1.91	2.59	1.94	1/2,9/16,5/8,3/4	-	-	450
M10D14L	2011136	10	31.44	28.44	5.34	18.00	1.91	2.59	1.94	1/2,9/16,5/8,3/4	-	-	210
M10D14LM	2011141	10	31.44	28.44	7.34	18.00	1.91	2.59	1.94	1/2,9/16,5/8,3/4	-	-	310
M10D14M	2011137	10	31.44	28.44	10.28	18.00	1.91	2.59	1.94	1/2,9/16,5/8,3/4	-	-	397
M10D14H	2011138	10	31.44	28.44	14.72	18.00	1.91	2.59	1.94	1/2,9/16,5/8,3/4	-	-	560
M10T10L	2011139	10	27.56	24.97	7.69	14.00	1.91	2.59	1.94	7/16,1/2,9/16,5/8	-	-	201
M10T10M	2011140	10	27.56	24.97	11.09	14.00	1.91	2.59	1.94	7/16,1/2,9/16,5/8	-	-	265
<b>15 Tons</b>													
M15S10L	2011148	15	31.03	24.84	5.34	14.00	1.91	2.59	1.94	7/16,1/2,9/16,5/8	1.38	1.66	137
M15S10M	2011157	15	31.03	24.84	8.53	14.00	1.91	2.59	1.94	7/16,1/2,9/16,5/8	1.38	1.66	200
M15S12L	2011166	15	32.88	26.59	5.34	16.00	1.91	2.59	1.94	1/2,9/16,5/8,3/4	1.38	1.66	145
M15S12M	2011175	15	32.88	26.59	9.84	16.00	1.91	2.59	1.94	1/2,9/16,5/8,3/4	1.38	1.66	295
M15S12H	2011179	15	32.88	26.59	13.84	16.00	1.91	2.59	1.94	1/2,9/16,5/8,3/4	1.38	1.66	435
M15S14L	2011184	15	35.12	28.84	5.34	18.00	1.91	2.59	1.94	1/2,9/16,5/8,3/4	1.38	1.66	190
M15S14LM	2011185	15	35.12	28.84	7.34	18.00	1.91	2.59	1.94	1/2,9/16,5/8,3/4	1.38	1.66	290
M15S14M	2011193	15	35.12	28.84	10.28	18.00	1.91	2.59	1.94	1/2,9/16,5/8,3/4	1.38	1.66	370
M15S14H	2011198	15	35.12	28.84	14.72	18.00	1.91	2.59	1.94	1/2,9/16,5/8,3/4	1.38	1.66	545
M15S16L	2011202	15	37.38	31.09	5.34	20.25	1.91	2.59	1.94	9/16,5/8,3/4,7/8	1.38	1.66	240
M15S16M	2011211	15	37.38	31.09	9.72	20.25	1.91	2.59	1.94	9/16,5/8,3/4,7/8	1.38	1.66	390
M15S16H	2011215	15	37.38	31.09	12.22	20.25	1.91	2.59	1.94	9/16,5/8,3/4,7/8	1.38	1.66	540
M15D10L	2011220	15	27.43	24.84	5.34	14.00	1.91	2.59	1.94	7/16,1/2,9/16,5/8	—	—	161
M15D10M	2011229	15	27.43	24.84	8.53	14.00	1.91	2.59	1.94	7/16,1/2,9/16,5/8	—	—	220

McKissick Blocks

## 380 Series Crane Blocks

Model No.	Inquiry Stock No.	Working Load Limit (Tons) †	A Overall Length (in)	B Net Length (in)	E Thickness (in)	F Width (in)	H Throat Opening with Flapper (in)	J Hook Thickness (in)	K Hook Width (in)	Standard Wireline Sizes (in)*	Dead End ‡		Weight Each (lb)
											T Thickness (in)	U Pin Hole (in)	
M15D12L	2011233	15	29.19	26.59	5.34	16.00	1.91	2.59	1.94	1/2,9/16,5/8,3/4	—	—	195
M15D12M	2011238	15	29.19	26.59	9.84	16.00	1.91	2.59	1.94	1/2,9/16,5/8,3/4	—	—	295
M15D12H	2011243	15	29.19	26.59	13.84	16.00	1.91	2.59	1.94	1/2,9/16,5/8,3/4	—	—	450
M15D14L	2011256	15	31.44	28.84	5.34	18.00	1.91	2.59	1.94	1/2,9/16,5/8,3/4	—	—	210
M15D14LM	2011257	15	31.44	28.84	7.34	18.00	1.91	2.59	1.94	1/2,9/16,5/8,3/4	—	—	310
M15D14M	2011265	15	31.44	28.84	10.28	18.00	1.91	2.59	1.94	1/2,9/16,5/8,3/4	—	—	397
M15D14H	2011269	15	31.44	28.84	14.72	18.00	1.91	2.59	1.94	1/2,9/16,5/8,3/4	—	—	560
M15D16L	2011270	15	33.69	31.09	5.34	20.25	1.91	2.59	1.94	9/16,5/8,3/4,7/8	—	—	299
M15D16M	2011271	15	33.69	31.09	9.72	20.25	1.91	2.59	1.94	9/16,5/8,3/4,7/8	—	—	465
M15D16H	2011272	15	33.69	31.09	12.22	20.25	1.91	2.59	1.94	9/16,5/8,3/4,7/8	—	—	610
M15T10L	2011273	15	27.56	24.97	7.69	14.00	1.91	2.59	1.94	7/16,1/2,9/16,5/8	—	—	201
M15T10M	2011274	15	27.56	24.97	11.09	14.00	1.91	2.59	1.94	7/16,1/2,9/16,5/8	—	—	265
M15T12L	2011275	15	29.31	26.75	7.69	16.00	1.91	2.59	1.94	1/2,9/16,5/8,3/4	—	—	215
M15T12M	2011283	15	29.31	26.75	12.19	16.00	1.91	2.59	1.94	1/2,9/16,5/8,3/4	—	—	340
M15T12H	2011285	15	29.31	26.75	16.19	16.00	1.91	2.59	1.94	1/2,9/16,5/8,3/4	—	—	496
M15Q10L	2011287	15	27.50	24.91	9.94	14.00	1.91	2.59	1.94	7/16,1/2,9/16,5/8	—	—	258
M15Q10M	2011288	15	27.50	24.91	13.12	14.00	1.91	2.59	1.94	7/16,1/2,9/16,5/8	—	—	320
<b>20 Tons</b>													
M20S12L	2011289	20	34.82	28.12	5.84	16.00	2.75	2.97	2.38	1/2,9/16,5/8,3/4	1.38	1.66	200
M20S12M	2011290	20	34.82	28.12	10.34	16.00	2.75	2.97	2.38	1/2,9/16,5/8,3/4	1.38	1.66	310
M20S12H	2011291	20	34.82	28.12	14.34	16.00	2.75	2.97	2.38	1/2,9/16,5/8,3/4	1.38	1.66	470
M20S14L	2011301	20	37.06	30.38	5.84	18.00	2.75	2.97	2.38	1/2,9/16,5/8,3/4	1.38	1.66	240
M20S14LM	2011302	20	37.06	30.38	7.84	18.00	2.75	2.97	2.38	1/2,9/16,5/8,3/4	1.38	1.66	355
M20S14M	2011310	20	37.06	30.38	10.78	18.00	2.75	2.97	2.38	1/2,9/16,5/8,3/4	1.38	1.66	410
M20S14H	2011314	20	37.06	30.38	15.22	18.00	2.75	2.97	2.38	1/2,9/16,5/8,3/4	1.38	1.66	580
M20S16L	2011315	20	39.31	32.63	5.84	20.25	2.75	2.97	2.38	9/16,5/8,3/4,7/8	1.38	1.66	280
M20S16M	2011316	20	39.31	32.63	10.19	20.25	2.75	2.97	2.38	9/16,5/8,3/4,7/8	1.38	1.66	445
M20S16H	2011317	20	39.31	32.63	12.69	20.25	2.75	2.97	2.38	9/16,5/8,3/4,7/8	1.38	1.66	600
M20S18L	2011319	20	44.28	36.56	6.84	22.75	2.75	2.97	2.38	5/8,3/4,7/8,1	1.53	2.06	400
M20S18M	2011328	20	44.28	36.56	10.97	22.75	2.75	2.97	2.38	5/8,3/4,7/8,1	1.53	2.06	620
M20S18H	2011333	20	44.28	36.56	12.97	22.75	2.75	2.97	2.38	5/8,3/4,7/8,1	1.53	2.06	760
M20S24L	2011330	20	50.19	42.44	6.84	28.75	2.75	2.97	2.38	7/8,1,1-1/8,1-1/4	1.38	1.66	545
M20S24M	2011331	20	50.19	42.44	14.59	28.75	2.75	2.97	2.38	7/8,1,1-1/8,1-1/4	1.38	1.66	1177
M20S24H	2011332	20	50.19	42.44	18.59	28.75	2.75	2.97	2.38	7/8,1,1-1/8,1-1/4	1.38	1.66	1660
M20D10L	2011335	20	29.38	26.38	5.84	14.00	2.75	2.97	2.38	7/16,1/2,9/16,5/8	—	—	200
M20D10M	2011337	20	29.38	26.38	9.03	14.00	2.75	2.97	2.38	7/16,1/2,9/16,5/8	—	—	260
M20D12L	2011346	20	31.12	28.12	5.84	16.00	2.75	2.97	2.38	1/2,9/16,5/8,3/4	—	—	228
M20D12M	2011355	20	31.12	28.12	10.34	16.00	2.75	2.97	2.38	1/2,9/16,5/8,3/4	—	—	340
M20D12H	2011364	20	31.12	28.12	14.34	16.00	2.75	2.97	2.38	1/2,9/16,5/8,3/4	—	—	505
M20D14L	2011373	20	33.38	30.38	5.84	18.00	2.75	2.97	2.38	1/2,9/16,5/8,3/4	—	—	280
M20D14LM	2011374	20	33.38	30.38	7.84	18.00	2.75	2.97	2.38	1/2,9/16,5/8,3/4	—	—	380
M20D14M	2011375	20	33.38	30.38	10.78	18.00	2.75	2.97	2.38	1/2,9/16,5/8,3/4	—	—	465
M20D14H	2011377	20	33.38	30.38	15.22	18.00	2.75	2.97	2.38	1/2,9/16,5/8,3/4	—	—	620
M20D16L	2011378	20	35.62	32.62	5.84	20.25	2.75	2.97	2.38	9/16,5/8,3/4,7/8	—	—	325
M20D16M	2011379	20	35.62	32.62	10.22	20.25	2.75	2.97	2.38	9/16,5/8,3/4,7/8	—	—	480
M20D16H	2011380	20	35.62	32.62	12.72	20.25	2.75	2.97	2.38	9/16,5/8,3/4,7/8	—	—	635
M20T10L	2011381	20	29.50	26.5	8.19	14.00	2.75	2.97	2.38	7/16,1/2,9/16,5/8	—	—	238
M20T10M	2011382	20	29.50	26.5	11.38	14.00	2.75	2.97	2.38	7/16,1/2,9/16,5/8	—	—	300
M20T12L	2011391	20	31.25	28.25	8.19	16.00	2.75	2.97	2.38	1/2,9/16,5/8,3/4	—	—	266
M20T12M	2011400	20	31.25	28.25	12.66	16.00	2.75	2.97	2.38	1/2,9/16,5/8,3/4	—	—	390
M20T12H	2011409	20	31.25	28.25	16.69	16.00	2.75	2.97	2.38	1/2,9/16,5/8,3/4	—	—	555
M20T14L	2011418	20	33.50	30.50	8.19	18.00	2.75	2.97	2.38	1/2,9/16,5/8,3/4	—	—	335
M20T14LM	2011420	20	33.50	30.50	10.19	18.00	2.75	2.97	2.38	1/2,9/16,5/8,3/4	—	—	430
M20T14M	2011427	20	33.50	30.50	13.06	18.00	2.75	2.97	2.38	1/2,9/16,5/8,3/4	—	—	520
M20T14H	2011432	20	33.50	30.50	17.50	18.00	2.75	2.97	2.38	1/2,9/16,5/8,3/4	—	—	675
M20Q10L	2011433	20	29.44	26.44	10.44	14.00	2.75	2.97	2.38	7/16,1/2,9/16,5/8	—	—	310
M20Q10M	2011434	20	29.44	26.44	13.62	14.00	2.75	2.97	2.38	7/16,1/2,9/16,5/8	—	—	360
M20Q12L	2011435	20	31.19	28.19	10.44	16.00	2.75	2.97	2.38	1/2,9/16,5/8,3/4	—	—	335
M20Q12M	2011436	20	31.19	28.19	14.94	16.00	2.75	2.97	2.38	1/2,9/16,5/8,3/4	—	—	490
M20Q12H	2011437	20	31.19	28.19	18.94	16.00	2.75	2.97	2.38	1/2,9/16,5/8,3/4	—	—	620
<b>25 Tons @ - Ultimate Load is 3.6 times the Working Load Limit</b>													
M25S14L	2011441	25@	37.06	30.38	5.84	18.00	2.75	2.97	2.38	1/2,9/16,5/8,3/4	1.38	1.66	240
M25S14LM	2011443	25@	37.06	30.38	7.84	18.00	2.75	2.97	2.38	1/2,9/16,5/8,3/4	1.38	1.66	350
M25S14M	2011445	25@	37.06	30.38	10.78	18.00	2.75	2.97	2.38	1/2,9/16,5/8,3/4	1.38	1.66	415
M25S14H	2011448	25@	37.06	30.38	15.22	18.00	2.75	2.97	2.38	1/2,9/16,5/8,3/4	1.38	1.66	560
M25S16L	2011451	25@	39.31	32.62	5.84	20.25	2.75	2.97	2.38	9/16,5/8,3/4,7/8	1.50	1.66	280
M25S16M	2011454	25@	39.31	32.62	10.22	20.25	2.75	2.97	2.38	9/16,5/8,3/4,7/8	1.50	1.66	445
M25S16H	2011457	25@	39.31	32.62	12.72	20.25	2.75	2.97	2.38	9/16,5/8,3/4,7/8	1.50	1.66	590
M25S18L	2011461	25@	44.28	36.56	6.84	22.75	2.75	2.97	2.38	5/8,3/4,7/8,1	1.53	2.06	390
M25S18M	2011463	25@	44.28	36.56	10.97	22.75	2.75	2.97	2.38	5/8,3/4,7/8,1	1.53	2.06	620

# McKissick® 380 Series Crane Blocks

## 380 Series Crane Blocks

Model No.	Inquiry Stock No.	Working Load Limit (Tons) †	A Overall Length (in)	B Net Length (in)	E Thickness (in)	F Width (in)	H Throat Opening with Flapper (in)	J Hook Thickness (in)	K Hook Width (in)	Standard Wireline Sizes (in)*	Dead End ‡		Weight Each (lb)
											T Thickness (in)	U Pin Hole (in)	
M25S18H	2011467	25@	44.28	36.56	12.97	22.75	2.75	2.97	2.38	5/8,3/4,7/8,1	1.53	2.06	760
M25S20L	2011458	25@	46.19	38.44	6.84	24.75	2.75	2.97	2.38	3/4,7/8,1,1-1/8	1.50	2.06	435
M25S20M	2011459	25@	46.19	38.44	11.34	24.75	2.75	2.97	2.38	3/4,7/8,1,1-1/8	1.50	2.06	655
M25S20H	2011460	25@	46.19	38.44	15.34	24.75	2.75	2.97	2.38	3/4,7/8,1,1-1/8	1.50	2.06	803
M25S24L	2011464	25@	50.19	42.44	6.84	28.75	2.75	2.97	2.38	7/8,1,1-1/8,1-1/4	1.50	2.06	545
M25S24M	2011465	25@	50.19	42.44	14.59	28.75	2.75	2.97	2.38	7/8,1,1-1/8,1-1/4	1.50	2.06	1180
M25S24H	2011466	25@	50.19	42.44	18.59	28.75	2.75	2.97	2.38	7/8,1,1-1/8,1-1/4	1.50	2.06	1660
M25D12L	2011468	25@	31.12	28.12	5.84	16.00	2.75	2.97	2.38	1/2,9/16,5/8,3/4	—	—	228
M25D12M	2011469	25@	31.12	28.12	10.34	16.00	2.75	2.97	2.38	1/2,9/16,5/8,3/4	—	—	340
M25D12H	2011470	25@	31.12	28.12	14.34	16.00	2.75	2.97	2.38	1/2,9/16,5/8,3/4	—	—	505
M25D14L	2011472	25@	33.38	30.38	5.84	18.00	2.75	2.97	2.38	1/2,9/16,5/8,3/4	—	—	280
M25D14LM	2011481	25@	33.38	30.38	7.75	18.00	2.75	2.97	2.38	1/2,9/16,5/8,3/4	—	—	350
M25D14M	2011490	25@	33.38	30.38	10.78	18.00	2.75	2.97	2.38	1/2,9/16,5/8,3/4	—	—	465
M25D14H	2011495	25@	33.38	30.38	15.22	18.00	2.75	2.97	2.38	1/2,9/16,5/8,3/4	—	—	610
M25D16L	2011499	25@	35.63	32.62	5.84	20.25	2.75	2.97	2.38	9/16,5/8,3/4,7/8	—	—	325
M25D16M	2011508	25@	35.63	32.62	10.22	20.25	2.75	2.97	2.38	9/16,5/8,3/4,7/8	—	—	480
M25D16H	2011512	25@	35.63	32.62	12.72	20.25	2.75	2.97	2.38	9/16,5/8,3/4,7/8	—	—	635
M25D18L	2011576	25@	39.50	36.50	6.84	22.75	2.75	2.97	2.38	5/8,3/4,7/8,1	—	—	470
M25D18M	2011579	25@	39.50	36.50	10.97	22.75	2.75	2.97	2.38	5/8,3/4,7/8,1	—	—	705
M25D18H	2011581	25@	39.50	36.50	12.97	22.75	2.75	2.97	2.38	5/8,3/4,7/8,1	—	—	840
M25T10L	2011514	25@	29.50	26.50	8.19	14.00	2.75	2.97	2.38	7/16,1/2,9/16,5/8	—	—	238
M25T10M	2011515	25@	29.50	26.50	11.38	14.00	2.75	2.97	2.38	7/16,1/2,9/16,5/8	—	—	300
M25T12L	2011517	25@	31.25	28.25	8.19	16.00	2.75	2.97	2.38	1/2,9/16,5/8,3/4	—	—	266
M25T12M	2011526	25@	31.25	28.25	12.66	16.00	2.75	2.97	2.38	1/2,9/16,5/8,3/4	—	—	390
M25T12H	2011531	25@	31.25	28.25	16.69	16.00	2.75	2.97	2.38	1/2,9/16,5/8,3/4	—	—	540
M25T14L	2011535	25@	33.50	30.50	8.19	18.00	2.75	2.97	2.38	1/2,9/16,5/8,3/4	—	—	335
M25T14LM	2011540	25@	33.50	30.50	10.19	18.00	2.75	2.97	2.38	1/2,9/16,5/8,3/4	—	—	495
M25T14M	2011544	25@	33.50	30.50	13.06	18.00	2.75	2.97	2.38	1/2,9/16,5/8,3/4	—	—	520
M25T14H	2011553	25@	33.50	30.50	17.5	18.00	2.75	2.97	2.38	1/2,9/16,5/8,3/4	—	—	675
M25T16L	2011562	25@	35.75	32.75	8.19	20.25	2.75	2.97	2.38	9/16,5/8,3/4,7/8	—	—	389
M25T16M	2011571	25@	35.75	32.75	12.53	20.25	2.75	2.97	2.38	9/16,5/8,3/4,7/8	—	—	555
M25T16H	2011575	25@	35.75	32.75	15.03	20.25	2.75	2.97	2.38	9/16,5/8,3/4,7/8	—	—	700
M25T18L	2011578	25@	39.53	36.56	9.91	22.75	2.75	2.97	2.38	5/8,3/4,7/8,1	—	—	585
M25T18M	2011580	25@	39.53	36.56	14.03	22.75	2.75	2.97	2.38	5/8,3/4,7/8,1	—	—	805
M25T18H	2011587	25@	39.53	36.56	16.03	22.75	2.75	2.97	2.38	5/8,3/4,7/8,1	—	—	939
M25Q10L	2011588	25@	29.44	26.44	10.44	14.00	2.75	2.97	2.38	7/16,1/2,9/16,5/8	—	—	310
M25Q10M	2011589	25@	29.44	26.44	13.62	14.00	2.75	2.97	2.38	7/16,1/2,9/16,5/8	—	—	370
M25Q12L	2011590	25@	31.19	28.19	10.44	16.00	2.75	2.97	2.38	1/2,9/16,5/8,3/4	—	—	335
M25Q12M	2011591	25@	31.19	28.19	14.94	16.00	2.75	2.97	2.38	1/2,9/16,5/8,3/4	—	—	455
M25Q12H	2011592	25@	31.19	28.19	18.94	16.00	2.75	2.97	2.38	1/2,9/16,5/8,3/4	—	—	620
M25Q14L	2011593	25@	33.44	30.44	10.44	18.00	2.75	2.97	2.38	1/2,9/16,5/8,3/4	—	—	426
M25Q14LM	2011596	25@	33.44	30.44	12.44	18.00	2.75	2.97	2.38	1/2,9/16,5/8,3/4	—	—	485
M25Q14H	2011594	25@	33.44	30.44	15.38	18.00	2.75	2.97	2.38	1/2,9/16,5/8,3/4	—	—	602
M25Q14M	2011595	25@	33.44	30.44	19.81	18.00	2.75	2.97	2.38	1/2,9/16,5/8,3/4	—	—	750
<b>30 Tons</b>													
M30S16L	2011598	30	43.41	36.09	5.84	20.25	3.25	3.62	3.00	9/16,5/8, 3/4,7/8	1.50	1.66	305
M30S16M	2011607	30	43.41	36.09	10.22	20.25	3.25	3.62	3.00	9/16,5/8, 3/4,7/8	1.50	1.66	465
M30S16H	2011613	30	43.41	36.09	12.72	20.25	3.25	3.62	3.00	9/16,5/8, 3/4,7/8	1.50	1.66	620
M30S18L	2011616	30	46.00	37.59	6.84	22.75	3.25	3.62	3.00	5/8,3/4, 7/8, 1	1.53	2.06	420
M30S18M	2011625	30	46.00	37.59	10.97	22.75	3.25	3.62	3.00	5/8,3/4, 7/8, 1	1.53	2.06	640
M30S18H	2011629	30	46.00	37.59	12.96	22.75	3.25	3.62	3.00	5/8,3/4, 7/8, 1	1.53	2.06	774
M30S20L	2011631	30	49.5	41.09	6.84	24.75	3.25	3.62	3.00	3/4,7/8, 1,1-1/8	1.50	2.06	468
M30S20M	2011634	30	49.5	41.09	11.34	24.75	3.25	3.62	3.00	3/4,7/8, 1,1-1/8	1.50	2.06	765
M30S20H	2011638	30	49.5	41.09	15.34	24.75	3.25	3.62	3.00	3/4,7/8, 1,1-1/8	1.50	2.06	1120
M30S24L	2011639	30	53.5	45.09	6.84	28.75	3.25	3.62	3.00	7/8,1,1-1/8,1-1/4	1.50	2.06	740
M30S24M	2011640	30	53.5	45.09	14.59	28.75	3.25	3.62	3.00	7/8,1,1-1/8,1-1/4	1.50	2.06	1410
M30S24H	2011641	30	53.5	45.09	18.59	28.75	3.25	3.62	3.00	7/8,1,1-1/8,1-1/4	1.50	2.06	1890
M30D14L	2011643	30	37.47	33.84	5.84	18.00	3.25	3.62	3.00	1/2,9/16, 5/8,3/4	—	—	298
M30D14LM	2011659	30	37.47	33.84	7.84	18.00	3.25	3.62	3.00	1/2,9/16, 5/8,3/4	—	—	380
M30D14M	2011652	30	37.47	33.84	10.78	18.00	3.25	3.62	3.00	1/2,9/16, 5/8,3/4	—	—	480
M30D14H	2011658	30	37.47	33.84	15.22	18.00	3.25	3.62	3.00	1/2,9/16, 5/8,3/4	—	—	646
M30D16L	2011661	30	39.72	36.09	5.84	20.25	3.25	3.62	3.00	9/16,5/8, 3/4,7/8	—	—	350
M30D16M	2011670	30	39.72	36.09	10.22	20.25	3.25	3.62	3.00	9/16,5/8, 3/4,7/8	—	—	508
M30D16H	2011672	30	39.72	36.09	12.72	20.25	3.25	3.62	3.00	9/16,5/8, 3/4,7/8	—	—	654
M30D18L	2011675	30	41.25	37.59	6.84	22.75	3.25	3.62	3.00	5/8,3/4, 7/8, 1	—	—	490
M30D18M	2011676	30	41.25	37.59	10.97	22.75	3.25	3.62	3.00	5/8,3/4, 7/8, 1	—	—	710
M30D18H	2011677	30	41.25	37.59	12.96	22.75	3.25	3.62	3.00	5/8,3/4, 7/8, 1	—	—	844
M30T12L	2011679	30	35.25	31.59	8.19	16.00	3.25	3.62	3.00	1/2,9/16, 5/8,3/4	—	—	320
M30T12M	2011680	30	35.25	31.59	12.66	16.00	3.25	3.62	3.00	1/2,9/16, 5/8,3/4	—	—	444
M30T12H	2011681	30	35.25	31.59	16.69	16.00	3.25	3.62	3.00	1/2,9/16, 5/8,3/4	—	—	595

McKissick Blocks



## 380 Series Crane Blocks

Model No.	Inquiry Stock No.	Working Load Limit (Tons) †	A Overall Length (in)	B Net Length (in)	E Thickness (in)	F Width (in)	H Throat Opening with Flapper (in)	J Hook Thickness (in)	K Hook Width (in)	Standard Wireline Sizes (in)*	Dead End ‡		Weight Each (lb)
											T Thickness (in)	U Pin Hole (in)	
M30T14L	2011688	30	37.50	33.84	8.19	18.00	3.25	3.62	3.00	1/2, 9/16, 5/8, 3/4	—	—	390
M30T14LM	2011703	30	37.50	33.84	10.12	18.00	3.25	3.62	3.00	1/2, 9/16, 5/8, 3/4	—	—	480
M30T14M	2011697	30	37.50	33.84	13.06	18.00	3.25	3.62	3.00	1/2, 9/16, 5/8, 3/4	—	—	575
M30T14H	2011702	30	37.50	33.84	17.50	18.00	3.25	3.62	3.00	1/2, 9/16, 5/8, 3/4	—	—	743
M30T16L	2011706	30	39.75	36.09	8.19	20.25	3.25	3.62	3.00	9/16, 5/8, 3/4, 7/8	—	—	454
M30T16M	2011708	30	39.75	36.09	12.53	20.25	3.25	3.62	3.00	9/16, 5/8, 3/4, 7/8	—	—	610
M30T16H	2011710	30	39.75	36.09	15.03	20.25	3.25	3.62	3.00	9/16, 5/8, 3/4, 7/8	—	—	755
M30T18L	2011712	30	41.25	37.59	9.91	22.75	3.25	3.62	3.00	5/8, 3/4, 7/8, 1	—	—	620
M30T18M	2011715	30	41.25	37.59	14.03	22.75	3.25	3.62	3.00	5/8, 3/4, 7/8, 1	—	—	855
M30T18H	2011719	30	41.25	37.59	16.03	22.75	3.25	3.62	3.00	5/8, 3/4, 7/8, 1	—	—	989
M30T20L	2011742	30	43.25	39.59	9.91	24.75	3.25	3.62	3.00	3/4, 7/8, 1, 1-1/8	—	—	688
M30T20M	2011743	30	43.25	39.59	14.41	24.75	3.25	3.62	3.00	3/4, 7/8, 1, 1-1/8	—	—	990
M30T20H	2011744	30	43.25	39.59	18.41	24.75	3.25	3.62	3.00	3/4, 7/8, 1, 1-1/8	—	—	1340
M30Q10L	2011714	30	33.50	29.84	10.44	14.00	3.25	3.62	3.00	7/16, 1/2, 9/16, 5/8	—	—	350
M30Q10M	2011716	30	33.50	29.84	13.62	14.00	3.25	3.62	3.00	7/16, 1/2, 9/16, 5/8	—	—	405
M30Q12L	2011717	30	35.25	31.59	10.44	16.00	3.25	3.62	3.00	1/2, 9/16, 5/8, 3/4	—	—	370
M30Q12M	2011718	30	35.25	31.59	14.94	16.00	3.25	3.62	3.00	1/2, 9/16, 5/8, 3/4	—	—	496
M30Q12H	2011720	30	35.25	31.59	18.94	16.00	3.25	3.62	3.00	1/2, 9/16, 5/8, 3/4	—	—	655
M30Q14L	2011724	30	37.50	33.84	10.44	18.00	3.25	3.62	3.00	1/2, 9/16, 5/8, 3/4	—	—	455
M30Q14LM	2011741	30	37.50	33.84	12.44	18.00	3.25	3.62	3.00	1/2, 9/16, 5/8, 3/4	—	—	520
M30Q14M	2011733	30	37.50	33.84	15.44	18.00	3.25	3.62	3.00	1/2, 9/16, 5/8, 3/4	—	—	640
M30Q14H	2011737	30	37.50	33.84	19.88	18.00	3.25	3.62	3.00	1/2, 9/16, 5/8, 3/4	—	—	798
M30Q16L	2011738	30	39.75	36.09	10.44	20.25	3.25	3.62	3.00	9/16, 5/8, 3/4, 7/8	—	—	430
M30Q16M	2011739	30	39.75	36.09	14.88	20.25	3.25	3.62	3.00	9/16, 5/8, 3/4, 7/8	—	—	585
M30Q16H	2011740	30	39.75	36.09	17.38	20.25	3.25	3.62	3.00	9/16, 5/8, 3/4, 7/8	—	—	731
<b>35 Tons</b>													
M35S18L	2011745	35	50.00	40.69	6.84	22.75	3.00	4.56	3.62	5/8, 3/4, 7/8, 1	1.50	2.06	485
M35S18M	2011746	35	50.00	40.69	10.97	22.75	3.00	4.56	3.62	5/8, 3/4, 7/8, 1	1.50	2.06	731
M35S18H	2011747	35	50.00	40.69	12.97	22.75	3.00	4.56	3.62	5/8, 3/4, 7/8, 1	1.50	2.06	865
M35S20L	2011748	35	53.50	44.19	6.84	24.75	3.00	4.56	3.62	3/4, 7/8, 1, 1-1/8	1.50	2.06	539
M35S20M	2011751	35	53.50	44.49	11.34	24.75	3.00	4.56	3.62	3/4, 7/8, 1, 1-1/8	1.50	2.06	835
M35S20H	2011755	35	53.50	44.19	15.34	24.75	3.00	4.56	3.62	3/4, 7/8, 1, 1-1/8	1.50	2.06	1181
M35S24L	2011752	35	57.50	48.19	6.84	28.75	3.00	4.56	3.62	7/8, 1, 1-1/8, 1-1/4	1.50	2.06	740
M35S24M	2011753	35	57.50	48.19	14.59	28.75	3.00	4.56	3.62	7/8, 1, 1-1/8, 1-1/4	1.50	2.06	1410
M35S24H	2011754	35	57.50	48.19	18.59	28.75	3.00	4.56	3.62	7/8, 1, 1-1/8, 1-1/4	1.50	2.06	1890
M35D16L	2011756	35	43.75	39.19	6.84	20.25	3.00	4.56	3.62	9/16, 5/8, 3/4, 7/8	—	—	430
M35D16M	2011757	35	43.75	39.19	11.22	20.25	3.00	4.56	3.62	9/16, 5/8, 3/4, 7/8	—	—	585
M35D16H	2011758	35	43.75	39.19	13.72	20.25	3.00	4.56	3.62	9/16, 5/8, 3/4, 7/8	—	—	731
M35D18L	2011760	35	41.22	37.59	9.91	22.75	3.00	4.56	3.62	5/8, 3/4, 7/8, 1	—	—	560
M35D18M	2011769	35	41.22	37.59	14.03	22.75	3.00	4.56	3.62	5/8, 3/4, 7/8, 1	—	—	805
M35D18H	2011774	35	41.22	37.59	16.03	22.75	3.00	4.56	3.62	5/8, 3/4, 7/8, 1	—	—	934
M35T14L	2011778	35	41.56	36.94	8.19	18.00	3.00	4.56	3.62	1/2, 9/16, 5/8, 3/4	—	—	450
M35T14LM	2011792	35	41.56	36.94	10.19	18.00	3.00	4.56	3.62	1/2, 9/16, 5/8, 3/4	—	—	540
M35T14M	2011787	35	41.56	36.94	13.06	18.00	3.00	4.56	3.62	1/2, 9/16, 5/8, 3/4	—	—	630
M35T14H	2011793	35	41.56	36.94	17.50	18.00	3.00	4.56	3.62	1/2, 9/16, 5/8, 3/4	—	—	788
M35T16L	2011794	35	43.81	39.19	8.19	20.25	3.00	4.56	3.62	9/16, 5/8, 3/4, 7/8	—	—	500
M35T16M	2011795	35	43.81	39.19	12.53	20.25	3.00	4.56	3.62	9/16, 5/8, 3/4, 7/8	—	—	667
M35T16H	2011796	35	43.81	39.19	15.03	20.25	3.00	4.56	3.62	9/16, 5/8, 3/4, 7/8	—	—	805
M35T18L	2011797	35	45.25	40.69	9.91	22.75	3.00	4.56	3.62	5/8, 3/4, 7/8, 1	—	—	680
M35T18M	2011799	35	45.25	40.69	14.03	22.75	3.00	4.56	3.62	5/8, 3/4, 7/8, 1	—	—	899
M35T18H	2011802	35	45.25	40.69	16.03	22.75	3.00	4.56	3.62	5/8, 3/4, 7/8, 1	—	—	1035
M35T20L	2011798	35	48.75	44.19	9.91	24.75	3.00	4.56	3.62	3/4, 7/8, 1, 1-1/8	—	—	745
M35T20M	2011800	35	48.75	44.19	14.41	24.75	3.00	4.56	3.62	3/4, 7/8, 1, 1-1/8	—	—	1056
M35T20H	2011801	35	48.75	44.19	18.41	24.75	3.00	4.56	3.62	3/4, 7/8, 1, 1-1/8	—	—	1400
M35Q12L	2011803	35	39.31	34.69	10.44	16.00	3.00	4.56	3.62	1/2, 9/16, 5/8, 3/4	—	—	438
M35Q12M	2011804	35	39.31	34.69	14.94	16.00	3.00	4.56	3.62	1/2, 9/16, 5/8, 3/4	—	—	555
M35Q12H	2011805	35	39.31	34.69	18.94	16.00	3.00	4.56	3.62	1/2, 9/16, 5/8, 3/4	—	—	710
M35Q14L	2011806	35	41.56	36.94	10.44	18.00	3.00	4.56	3.62	1/2, 9/16, 5/8, 3/4	—	—	455
M35Q14LM	2011807	35	41.56	36.94	12.44	18.00	3.00	4.56	3.62	1/2, 9/16, 5/8, 3/4	—	—	520
M35Q14M	2011814	35	41.56	36.94	15.44	18.00	3.00	4.56	3.62	1/2, 9/16, 5/8, 3/4	—	—	648
M35Q14H	2011817	35	41.56	36.94	19.88	18.00	3.00	4.56	3.62	1/2, 9/16, 5/8, 3/4	—	—	815
M35Q16L	2011818	35	43.81	39.19	10.44	20.25	3.00	4.56	3.62	9/16, 5/8, 3/4, 7/8	—	—	584
M35Q16M	2011819	35	43.81	39.19	14.88	20.25	3.00	4.56	3.62	9/16, 5/8, 3/4, 7/8	—	—	750
M35Q16H	2011820	35	43.81	39.19	17.38	20.25	3.00	4.56	3.62	9/16, 5/8, 3/4, 7/8	—	—	890
M35QN14L	2011815	35	45.00	36.94	13.25	18.00	3.00	4.56	3.62	1/2, 9/16, 5/8, 3/4	1.25	1.41	530
M35QN14LM	2011808	35	45.00	36.94	15.25	18.00	3.00	4.56	3.62	1/2, 9/16, 5/8, 3/4	1.25	1.41	620
M35QN14M	2011809	35	45.00	36.94	18.25	18.00	3.00	4.56	3.62	1/2, 9/16, 5/8, 3/4	1.25	1.41	810
M35QN14H	2011810	35	45.00	36.94	19.69	18.00	3.00	4.56	3.62	1/2, 9/16, 5/8, 3/4	1.25	1.41	960
<b>40 Tons</b>													
M40S20L	2011833	40	55.81	46.00	7.81	24.75	3.00	4.56	3.62	3/4, 7/8, 1, 1-1/8	1.75	2.28	660

# McKissick® 380 Series Crane Blocks

## 380 Series Crane Blocks

Model No.	Inquiry Stock No.	Working Load Limit (Tons) †	A Overall Length (in)	B Net Length (in)	E Thickness (in)	F Width (in)	H Throat Opening with Flapper (in)	J Hook Thickness (in)	K Hook Width (in)	Standard Wireline Sizes (in)*	Dead End ‡		Weight Each (lb)
											T Thickness (in)	U Pin Hole (in)	
M40S20M	2011834	40	55.81	46.00	12.31	24.75	3.00	4.56	3.62	3/4, 7/8, 1, 1-1/8	1.75	2.28	955
M40S20H	2011835	40	55.81	46.00	16.31	24.75	3.38	5.06	3.72	3/4, 7/8, 1, 1-1/8	1.75	2.28	1299
M40S24L	2011825	40	59.81	50.00	7.81	28.75	3.38	5.06	3.72	7/8, 1, 1-1/8, 1-1/4	1.75	2.28	790
M40S24M	2011829	40	59.81	50.00	15.56	28.75	3.38	5.06	3.72	7/8, 1, 1-1/8, 1-1/4	1.75	2.28	1480
M40S24H	2011832	40	59.81	50.00	19.56	28.75	3.38	5.06	3.72	7/8, 1, 1-1/8, 1-1/4	1.75	2.28	1940
M40D18L	2011918	40	47.56	42.50	7.81	22.75	3.38	5.06	3.72	5/8, 3/4, 7/8, 1	—	—	685
M40D18M	2011919	40	47.56	42.50	11.94	22.75	3.38	5.06	3.72	5/8, 3/4, 7/8, 1	—	—	926
M40D18H	2011920	40	47.56	42.50	13.94	22.75	3.38	5.06	3.72	5/8, 3/4, 7/8, 1	—	—	1073
M40D20L	2011841	40	50.06	45.00	7.81	24.75	3.38	5.06	3.72	3/4, 7/8, 1, 1-1/8	—	—	759
M40D20M	2011850	40	50.06	45.00	12.31	24.75	3.38	5.06	3.72	3/4, 7/8, 1, 1-1/8	—	—	1090
M40D20H	2011854	40	50.06	45.00	16.31	24.75	3.38	5.06	3.72	3/4, 7/8, 1, 1-1/8	—	—	1401
M40T14L	2011855	40	43.44	38.38	8.19	18.00	3.38	5.06	3.72	1/2, 9/16, 5/8, 3/4	—	—	519
M40T14M	2011856	40	43.44	38.38	13.06	18.00	3.38	5.06	3.72	1/2, 9/16, 5/8, 3/4	—	—	695
M40T14H	2011857	40	43.44	38.38	17.50	18.00	3.38	5.06	3.72	1/2, 9/16, 5/8, 3/4	—	—	843
M40T16L	2011859	40	45.69	40.62	8.19	20.25	3.38	5.06	3.72	9/16, 5/8, 3/4, 7/8	—	—	525
M40T16M	2011868	40	45.69	40.62	12.53	20.25	3.38	5.06	3.72	9/16, 5/8, 3/4, 7/8	—	—	690
M40T16H	2011871	40	45.69	40.62	15.03	20.25	3.38	5.06	3.72	9/16, 5/8, 3/4, 7/8	—	—	836
M40T18L	2011874	40	47.31	42.25	10.38	22.75	3.38	5.06	3.72	5/8, 3/4, 7/8, 1	—	—	799
M40T18M	2011877	40	47.31	42.25	14.50	22.75	3.38	5.06	3.72	5/8, 3/4, 7/8, 1	—	—	1019
M40T18H	2011881	40	47.31	42.25	16.50	22.75	3.38	5.06	3.72	5/8, 3/4, 7/8, 1	—	—	1158
M40T20L	2011882	40	50.06	45.00	10.38	24.75	3.38	5.06	3.72	3/4, 7/8, 1, 1-1/8	—	—	889
M40T20M	2011883	40	50.06	45.00	14.88	24.75	3.38	5.06	3.72	3/4, 7/8, 1, 1-1/8	—	—	1185
M40T20H	2011884	40	50.06	45.00	18.88	24.75	3.38	5.06	3.72	3/4, 7/8, 1, 1-1/8	—	—	1531
M40Q14L	2011885	40	43.44	38.38	10.44	18.00	3.38	5.06	3.72	1/2, 9/16, 5/8, 3/4	—	—	535
M40Q14M	2011886	40	43.44	38.38	15.44	18.00	3.38	5.06	3.72	1/2, 9/16, 5/8, 3/4	—	—	745
M40Q14H	2011891	40	43.44	38.38	16.88	18.00	3.38	5.06	3.72	1/2, 9/16, 5/8, 3/4	—	—	910
M40Q16L	2011895	40	45.69	40.62	10.44	20.25	3.38	5.06	3.72	9/16, 5/8, 3/4, 7/8	—	—	627
M40Q16M	2011904	40	45.69	40.62	14.88	20.25	3.38	5.06	3.72	9/16, 5/8, 3/4, 7/8	—	—	785
M40Q16H	2011908	40	45.69	40.62	17.38	20.25	3.38	5.06	3.72	9/16, 5/8, 3/4, 7/8	—	—	930
M40Q18L	2011910	40	47.31	42.25	13.31	22.75	3.38	5.06	3.72	5/8, 3/4, 7/8, 1	—	—	930
M40Q18M	2011913	40	47.31	42.25	17.44	22.75	3.38	5.06	3.72	5/8, 3/4, 7/8, 1	—	—	1150
M40Q18H	2011917	40	47.31	42.25	19.44	22.75	3.38	5.06	3.72	5/8, 3/4, 7/8, 1	—	—	1290
M40QN14L	2011921	40	47.00	38.88	13.25	18.00	3.38	5.06	3.72	1/2, 9/16, 5/8, 3/4	1.25	1.41	510
M40QN14M	2011922	40	47.00	38.88	18.25	18.00	3.38	5.06	3.72	1/2, 9/16, 5/8, 3/4	1.25	1.41	735
M40QN14H	2011923	40	47.00	38.88	19.69	18.00	3.38	5.06	3.72	1/2, 9/16, 5/8, 3/4	1.25	1.41	900
<b>45 Tons @ - Ultimate Load is 3.6 times the Working Load Limit</b>													
M45S24L	2011924	45@	59.81	50.00	7.81	28.75	3.38	5.06	3.72	7/8, 1, 1-1/8, 1-1/4	1.75	2.28	805
M45S24M	2011925	45@	59.81	50.00	15.56	28.75	3.38	5.06	3.72	7/8, 1, 1-1/8, 1-1/4	1.75	2.28	1445
M45S24H	2011926	45@	59.81	50.00	19.56	28.75	3.38	5.06	3.72	7/8, 1, 1-1/8, 1-1/4	1.75	2.28	1940
M45D20L	2011928	45@	50.06	45.00	7.81	24.75	3.38	5.06	3.72	3/4, 7/8, 1, 1-1/8	—	—	759
M45D20M	2011931	45@	50.06	45.00	12.31	24.75	3.38	5.06	3.72	3/4, 7/8, 1, 1-1/8	—	—	1055
M45D20H	2011937	45@	50.06	45.00	16.31	24.75	3.38	5.06	3.72	3/4, 7/8, 1, 1-1/8	—	—	1401
M45T16L	2011942	45@	45.69	40.62	8.19	20.25	3.38	5.06	3.72	9/16, 5/8, 3/4, 7/8	—	—	525
M45T16M	2011951	45@	45.69	40.62	12.53	20.25	3.38	5.06	3.72	9/16, 5/8, 3/4, 7/8	—	—	690
M45T16H	2011960	45@	45.69	40.62	15.03	20.25	3.38	5.06	3.72	9/16, 5/8, 3/4, 7/8	—	—	836
M45T18L	2011969	45@	47.31	42.25	10.38	22.75	3.38	5.06	3.72	5/8, 3/4, 7/8, 1	—	—	799
M45T18M	2011978	45@	47.31	42.25	14.50	22.75	3.38	5.06	3.72	5/8, 3/4, 7/8, 1	—	—	1019
M45T18H	2011987	45@	47.31	42.25	16.50	22.75	3.38	5.06	3.72	5/8, 3/4, 7/8, 1	—	—	1158
M45T20L	2011993	45@	50.06	45.00	10.38	24.75	3.38	5.06	3.72	3/4, 7/8, 1, 1-1/8	—	—	889
M45T20M	2011996	45@	50.06	45.00	14.88	24.75	3.38	5.06	3.72	3/4, 7/8, 1, 1-1/8	—	—	1185
M45T20H	2012000	45@	50.06	45.00	18.88	24.75	3.38	5.06	3.72	3/4, 7/8, 1, 1-1/8	—	—	1531
M45Q14L	2012001	45@	43.44	38.38	10.44	18.00	3.38	5.06	3.72	1/2, 9/16, 5/8, 3/4	—	—	535
M45Q14M	2012003	45@	43.44	38.38	15.44	18.00	3.38	5.06	3.72	1/2, 9/16, 5/8, 3/4	—	—	745
M45Q14H	2012004	45@	43.44	38.38	16.88	18.00	3.38	5.06	3.72	1/2, 9/16, 5/8, 3/4	—	—	910
M45Q16L	2012005	45@	45.69	40.62	10.44	20.25	3.38	5.06	3.72	9/16, 5/8, 3/4, 7/8	—	—	627
M45Q16M	2012006	45@	45.69	40.62	14.88	20.25	3.38	5.06	3.72	9/16, 5/8, 3/4, 7/8	—	—	785
M45Q16H	2012007	45@	45.69	40.62	17.38	20.25	3.38	5.06	3.72	9/16, 5/8, 3/4, 7/8	—	—	930
M45Q18L	2012008	45@	47.31	42.25	13.31	22.75	3.38	5.06	3.72	5/8, 3/4, 7/8, 1	—	—	930
M45Q18M	2012009	45@	47.31	42.25	17.44	22.75	3.38	5.06	3.72	5/8, 3/4, 7/8, 1	—	—	1150
M45Q18H	2012010	45@	47.31	42.25	19.44	22.75	3.38	5.06	3.72	5/8, 3/4, 7/8, 1	—	—	1290
M45QN16L	2011997	45@	49.19	40.62	13.25	20.25	3.38	5.06	3.72	9/16, 5/8, 3/4, 7/8	1.25	1.44	666
M45QN16M	2011998	45@	49.19	40.62	17.62	20.25	3.38	5.06	3.72	9/16, 5/8, 3/4, 7/8	1.25	1.44	822
M45QN16H	2011999	45@	49.19	40.62	20.12	20.25	3.38	5.06	3.72	9/16, 5/8, 3/4, 7/8	1.25	1.44	968
<b>50 Tons</b>													
M50S24L	2012015	50	64.12	53.12	7.81	28.75	4.12	6.00	4.44	7/8, 1, 1-1/8, 1-1/4	2.00	2.53	960
M50S24M	2012016	50	64.12	53.12	15.56	28.75	4.12	6.00	4.44	7/8, 1, 1-1/8, 1-1/4	2.00	2.53	1565
M50S24H	2012017	50	64.12	53.12	19.56	28.75	4.12	6.00	4.44	7/8, 1, 1-1/8, 1-1/4	2.00	2.53	2075
M50D24L	2012018	50	59.12	53.12	7.81	28.75	4.12	6.00	4.44	7/8, 1, 1-1/8, 1-1/4	—	—	1140
M50D24M	2012019	50	59.12	53.12	15.56	28.75	4.12	6.00	4.44	7/8, 1, 1-1/8, 1-1/4	—	—	1770
M50D24H	2012020	50	59.12	53.12	19.56	28.75	4.12	6.00	4.44	7/8, 1, 1-1/8, 1-1/4	—	—	2252

McKissick Blocks

## 380 Series Crane Blocks

Model No.	Inquiry Stock No.	Working Load Limit (Tons) †	A Overall Length (in)	B Net Length (in)	E Thickness (in)	F Width (in)	H Throat Opening with Flapper (in)	J Hook Thickness (in)	K Hook Width (in)	Standard Wireline Sizes (in)*	Dead End ‡		Weight Each (lb)
											T Thickness (in)	U Pin Hole (in)	
M50T18L	2012014	50	53.62	47.62	10.38	22.75	4.12	6.00	4.44	5/8, 3/4, 7/8, 1	—	—	930
M50T18M	2012023	50	53.62	47.62	14.50	22.75	4.12	6.00	4.44	5/8, 3/4, 7/8, 1	—	—	1100
M50T18H	2012027	50	53.62	47.62	16.50	22.75	4.12	6.00	4.44	5/8, 3/4, 7/8, 1	—	—	1240
M50T20L	2012032	50	54.12	48.12	10.38	24.75	4.12	6.00	4.44	3/4, 7/8, 1, 1-1/8	—	—	989
M50T20M	2012041	50	54.12	48.12	14.88	24.75	4.12	6.00	4.44	3/4, 7/8, 1, 1-1/8	—	—	1295
M50T20H	2012045	50	54.12	48.12	18.88	24.75	4.12	6.00	4.44	3/4, 7/8, 1, 1-1/8	—	—	1635
M50T24L	2012048	50	59.12	53.12	10.38	28.75	4.12	6.00	4.44	7/8, 1, 1-1/8, 1-1/4	—	—	1200
M50T24M	2012050	50	59.12	53.12	18.13	28.75	4.12	6.00	4.44	7/8, 1, 1-1/8, 1-1/4	—	—	1890
M50T24H	2012055	50	59.12	53.12	22.12	28.75	4.12	6.00	4.44	7/8, 1, 1-1/8, 1-1/4	—	—	2368
M50Q16L	2012059	50	49.88	43.88	13.31	20.25	4.12	6.00	4.44	9/16, 5/8, 3/4, 7/8	—	—	814
M50Q16M	2012068	50	49.88	43.88	17.69	20.25	4.12	6.00	4.44	9/16, 5/8, 3/4, 7/8	—	—	980
M50Q16H	2012073	50	49.88	43.88	20.19	20.25	4.12	6.00	4.44	9/16, 5/8, 3/4, 7/8	—	—	1125
M50Q18L	2012077	50	53.62	50.62	13.31	22.75	4.12	6.00	4.44	5/8, 3/4, 7/8, 1	—	—	995
M50Q18M	2012086	50	53.62	50.62	17.44	22.75	4.12	6.00	4.44	5/8, 3/4, 7/8, 1	—	—	1220
M50Q18H	2012091	50	53.62	50.62	19.44	22.75	4.12	6.00	4.44	5/8, 3/4, 7/8, 1	—	—	1360
M50Q20L	2012095	50	54.13	48.13	13.31	24.75	4.12	6.00	4.44	3/4, 7/8, 1, 1-1/8	—	—	1140
M50Q20M	2012097	50	54.13	48.13	17.81	24.75	4.12	6.00	4.44	3/4, 7/8, 1, 1-1/8	—	—	1490
M50Q20H	2012101	50	54.13	48.13	21.81	24.75	4.12	6.00	4.44	3/4, 7/8, 1, 1-1/8	—	—	1880
M50QN14L	2012056	50	51.75	41.88	13.25	18.00	4.12	6.00	4.44	1/2, 9/16, 5/8, 3/4	1.25	1.41	805
M50QN14M	2012057	50	51.75	41.88	18.19	18.00	4.12	6.00	4.44	1/2, 9/16, 5/8, 3/4	1.25	1.41	960
M50QN14H	2012058	50	51.75	41.88	22.63	18.00	4.12	6.00	4.44	1/2, 9/16, 5/8, 3/4	1.25	1.41	1185
M50QN16L	2012060	50	54.00	43.88	13.25	20.25	4.12	6.00	4.44	9/16, 5/8, 3/4, 7/8	1.25	1.41	875
M50QN16M	2012061	50	54.00	43.88	17.63	20.25	4.12	6.00	4.44	9/16, 5/8, 3/4, 7/8	1.25	1.41	1030
M50QN16H	2012062	50	54.00	43.88	20.13	20.25	4.12	6.00	4.44	9/16, 5/8, 3/4, 7/8	1.25	1.41	1180
M50SX14L	2012063	50	51.75	41.88	15.53	18.00	4.12	6.00	4.44	1/2, 9/16, 5/8, 3/4	1.25	1.41	926
M50SX14M	2012064	50	51.75	41.88	20.53	18.00	4.12	6.00	4.44	1/2, 9/16, 5/8, 3/4	1.25	1.41	1020
M50SX14H	2012065	50	51.75	41.88	24.94	18.00	4.12	6.00	4.44	1/2, 9/16, 5/8, 3/4	1.25	1.41	1250
<b>55 Tons</b>													
M55S24L	2012105	55	64.12	53.12	7.81	28.75	4.12	6.00	4.44	7/8, 1, 1-1/8, 1-1/4	2.00	2.53	960
M55S24M	2012106	55	64.12	53.12	15.56	28.75	4.12	6.00	4.44	7/8, 1, 1-1/8, 1-1/4	2.00	2.53	1595
M55S24H	2012107	55	64.12	53.12	19.56	28.75	4.12	6.00	4.44	7/8, 1, 1-1/8, 1-1/4	2.00	2.53	2075
M55D24L	2012108	55	59.12	53.12	7.81	28.75	4.12	6.00	4.44	7/8, 1, 1-1/8, 1-1/4	—	—	1140
M55D24M	2012109	55	59.12	53.12	15.56	28.75	4.12	6.00	4.44	7/8, 1, 1-1/8, 1-1/4	—	—	1770
M55D24H	2012110	55	59.12	53.12	19.56	28.75	4.12	6.00	4.44	7/8, 1, 1-1/8, 1-1/4	—	—	2250
M55T18L	2012104	55	53.62	47.62	10.38	22.75	4.12	6.00	4.44	5/8, 3/4, 7/8, 1	—	—	880
M55T18M	2012113	55	53.62	47.62	14.50	22.75	4.12	6.00	4.44	5/8, 3/4, 7/8, 1	—	—	1100
M55T18H	2012122	55	53.62	47.62	16.50	22.75	4.12	6.00	4.44	5/8, 3/4, 7/8, 1	—	—	1240
M55T20L	2012111	55	54.12	48.12	10.38	24.75	4.12	6.00	4.44	3/4, 7/8, 1, 1-1/8	—	—	989
M55T20M	2012114	55	54.12	48.12	14.88	24.75	4.12	6.00	4.44	3/4, 7/8, 1, 1-1/8	—	—	1295
M55T20H	2012123	55	54.12	48.12	18.88	24.75	4.12	6.00	4.44	3/4, 7/8, 1, 1-1/8	—	—	1635
M55T24L	2012112	55	59.12	53.12	10.38	28.75	4.12	6.00	4.44	7/8, 1, 1-1/8, 1-1/4	—	—	1200
M55T24M	2012124	55	59.12	53.12	18.13	28.75	4.12	6.00	4.44	7/8, 1, 1-1/8, 1-1/4	—	—	1890
M55T24H	2012125	55	59.12	53.12	22.13	28.75	4.12	6.00	4.44	7/8, 1, 1-1/8, 1-1/4	—	—	2368
M55Q16L	2012131	55	49.88	43.88	13.31	20.25	4.12	6.00	4.44	9/16, 5/8, 3/4, 7/8	-	-	814
M55Q16M	2012140	55	49.88	43.88	17.69	20.25	4.12	6.00	4.44	9/16, 5/8, 3/4, 7/8	-	-	980
M55Q16H	2012143	55	49.88	43.88	20.19	20.25	4.12	6.00	4.44	9/16, 5/8, 3/4, 7/8	-	-	1125
M55Q18L	2012146	55	53.63	50.63	13.31	22.75	4.12	6.00	4.44	5/8, 3/4, 7/8, 1	-	-	995
M55Q18M	2012149	55	53.63	50.63	17.44	22.75	4.12	6.00	4.44	5/8, 3/4, 7/8, 1	-	-	1220
M55Q18H	2012153	55	53.63	50.63	19.44	22.75	4.12	6.00	4.44	5/8, 3/4, 7/8, 1	-	-	1360
M55Q20L	2012171	55	54.12	48.12	13.31	24.75	4.12	6.00	4.44	3/4, 7/8, 1, 1-1/8	-	-	1140
M55Q20M	2012172	55	54.12	48.12	17.81	24.75	4.12	6.00	4.44	3/4, 7/8, 1, 1-1/8	-	-	1490
M55Q20H	2012173	55	54.12	48.12	22.81	24.75	4.12	6.00	4.44	3/4, 7/8, 1, 1-1/8	-	-	1855
M55QN14L	2012126	55	51.75	41.88	13.25	18.00	4.12	6.00	4.44	1/2, 9/16, 5/8, 3/4	1.25	1.41	840
M55QN14M	2012127	55	51.75	41.88	18.25	18.00	4.12	6.00	4.44	1/2, 9/16, 5/8, 3/4	1.25	1.41	1035
M55QN14H	2012128	55	51.75	41.88	22.62	18.00	4.12	6.00	4.44	1/2, 9/16, 5/8, 3/4	1.25	1.41	1185
M55QN16L	2012158	55	54.00	43.88	13.25	20.25	4.12	6.00	4.44	9/16, 5/8, 3/4, 7/8	1.25	1.41	875
M55QN16M	2012167	55	54.00	43.88	17.63	20.25	4.12	6.00	4.44	9/16, 5/8, 3/4, 7/8	1.25	1.41	1030
M55QN16H	2012170	55	54.00	43.88	20.13	20.25	4.12	6.00	4.44	9/16, 5/8, 3/4, 7/8	1.25	1.41	1180
M55QN18L	2012147	55	58.62	47.62	17.50	22.75	4.12	6.00	4.44	5/8, 3/4, 7/8, 1	1.25	1.41	1380
M55QN18M	2012150	55	58.62	47.62	21.62	22.75	4.12	6.00	4.44	5/8, 3/4, 7/8, 1	1.25	1.41	1600
M55QN18H	2012154	55	58.62	47.62	23.62	22.75	4.12	6.00	4.44	5/8, 3/4, 7/8, 1	1.25	1.41	1750
M55SX14L	2012135	55	51.75	41.88	15.53	18.00	4.12	6.00	4.44	1/2, 9/16, 5/8, 3/4	1.25	1.41	926
M55SX14M	2012141	55	51.75	41.88	20.47	18.00	4.12	6.00	4.44	1/2, 9/16, 5/8, 3/4	1.25	1.41	1020
M55SX14H	2012144	55	51.75	41.88	24.91	18.00	4.12	6.00	4.44	1/2, 9/16, 5/8, 3/4	1.25	1.41	1250
<b>60 Tons</b>													
M60D24L	2012175	60	59.12	53.12	7.81	28.75	4.12	6.00	4.44	7/8, 1, 1-1/8, 1-1/4	-	-	1140
M60D24M	2012179	60	59.12	53.12	12.31	28.75	4.12	6.00	4.44	7/8, 1, 1-1/8, 1-1/4	-	-	1770
M60D24H	2012183	60	59.12	53.12	19.56	28.75	4.12	6.00	4.44	7/8, 1, 1-1/8, 1-1/4	-	-	2250
M60T18L	2012187	60	53.62	47.62	10.38	22.75	4.12	6.00	4.44	5/8, 3/4, 7/8, 1	-	-	881
M60T18M	2012191	60	53.62	47.62	14.50	22.75	4.12	6.00	4.44	5/8, 3/4, 7/8, 1	-	-	1115

# McKissick® 380 Series Crane Blocks

## 380 Series Crane Blocks

Model No.	Inquiry Stock No.	Working Load Limit (Tons) †	A Overall Length (in)	B Net Length (in)	E Thickness (in)	F Width (in)	H Throat Opening with Flapper (in)	J Hook Thickness (in)	K Hook Width (in)	Standard Wireline Sizes (in)*	Dead End ‡		Weight Each (lb)
											T Thickness (in)	U Pin Hole (in)	
M60T18H	2012195	60	53.62	47.62	16.50	22.75	4.12	6.00	4.44	5/8, 3/4, 7/8, 1	-	-	1240
M60T20L	2012199	60	54.12	48.12	10.38	24.75	4.12	6.00	4.44	3/4, 7/8, 1, 1-1/8	-	-	950
M60T20M	2012203	60	54.12	48.12	14.88	24.75	4.12	6.00	4.44	3/4, 7/8, 1, 1-1/8	-	-	1330
M60T20H	2012207	60	54.12	48.12	18.88	24.75	4.12	6.00	4.44	3/4, 7/8, 1, 1-1/8	-	-	1695
M60T24L	2012211	60	59.12	53.12	10.31	28.75	4.12	6.00	4.44	7/8, 1, 1-1/8, 1-1/4	-	-	1255
M60T24M	2012215	60	59.12	53.12	18.12	28.75	4.12	6.00	4.44	7/8, 1, 1-1/8, 1-1/4	-	-	1890
M60T24H	2012219	60	59.12	53.12	22.01	28.75	4.12	6.00	4.44	7/8, 1, 1-1/8, 1-1/4	-	-	2365
M60Q16L	2012223	60	49.88	43.88	13.31	20.25	4.12	6.00	4.44	9/16, 5/8, 3/4, 7/8	-	-	905
M60Q16M	2012227	60	49.88	43.88	17.69	20.25	4.12	6.00	4.44	9/16, 5/8, 3/4, 7/8	-	-	1030
M60Q16H	2012231	60	49.88	43.88	20.19	20.25	4.12	6.00	4.44	9/16, 5/8, 3/4, 7/8	-	-	1220
M60Q18L	2012235	60	53.62	47.62	13.31	22.75	4.12	6.00	4.44	5/8, 3/4, 7/8, 1	-	-	1002
M60Q18M	2012239	60	53.62	47.62	17.44	22.75	4.12	6.00	4.44	5/8, 3/4, 7/8, 1	-	-	1228
M60Q18H	2012243	60	53.62	47.62	19.44	22.75	4.12	6.00	4.44	5/8, 3/4, 7/8, 1	-	-	1366
M60Q20L	2012247	60	54.12	48.12	13.31	24.75	4.12	6.00	4.44	3/4, 7/8, 1, 1-1/8	-	-	1140
M60Q20M	2012251	60	54.12	48.12	17.81	24.75	4.12	6.00	4.44	3/4, 7/8, 1, 1-1/8	-	-	1490
M60Q20H	2012255	60	54.12	48.12	21.81	24.75	4.12	6.00	4.44	3/4, 7/8, 1, 1-1/8	-	-	1855
M60Q24L	2012259	60	59.12	53.12	13.31	28.75	4.12	6.00	4.44	7/8, 1, 1-1/8, 1-1/4	-	-	1452
M60Q24M	2012263	60	59.12	53.12	21.06	28.75	4.12	6.00	4.44	7/8, 1, 1-1/8, 1-1/4	-	-	2120
M60Q24H	2012267	60	59.12	53.12	25.06	28.75	4.12	6.00	4.44	7/8, 1, 1-1/8, 1-1/4	-	-	2600
M60QN20L	2012271	60	59.12	48.12	17.50	24.75	4.12	6.00	4.44	3/4, 7/8, 1, 1-1/8	1.50	1.41	1565
M60QN20M	2012275	60	59.12	48.12	22.00	24.75	4.12	6.00	4.44	3/4, 7/8, 1, 1-1/8	1.50	1.41	1860
M60QN20H	2012279	60	59.12	48.12	26.00	24.75	4.12	6.00	4.44	3/4, 7/8, 1, 1-1/8	1.50	1.41	2210
M60SX14L	2012283	60	51.75	45.75	15.53	18.00	4.12	6.00	4.44	1/2, 9/16, 5/8, 3/4	1.25	1.41	925
M60SX14M	2012287	60	51.75	45.75	20.47	18.00	4.12	6.00	4.44	1/2, 9/16, 5/8, 3/4	1.25	1.41	1100
M60SX14H	2012291	60	51.75	45.75	24.84	18.00	4.12	6.00	4.44	1/2, 9/16, 5/8, 3/4	1.25	1.41	1250
M60SX18L	2012295	60	58.62	47.62	19.53	22.75	4.12	6.00	4.44	5/8, 3/4, 7/8, 1	1.50	2.06	1410
M60SX18M	2012299	60	58.62	47.62	23.66	22.75	4.12	6.00	4.44	5/8, 3/4, 7/8, 1	1.50	2.06	1650
M60SX18H	2012303	60	58.62	47.62	25.66	22.75	4.12	6.00	4.44	5/8, 3/4, 7/8, 1	1.50	2.06	1798
<b>65 Tons</b>													
M65D24L	2012376	65	59.12	53.12	7.81	28.75	4.12	6.00	4.44	7/8, 1, 1-1/8, 1-1/4	—	—	1140
M65D24M	2012377	65	59.12	53.12	15.56	28.75	4.12	6.00	4.44	7/8, 1, 1-1/8, 1-1/4	—	—	1770
M65D24H	2012378	65	59.12	53.12	19.56	28.75	4.12	6.00	4.44	7/8, 1, 1-1/8, 1-1/4	—	—	2252
M65T18L	2012304	65	53.62	47.62	10.38	22.75	4.12	6.00	4.44	5/8, 3/4, 7/8, 1	—	—	930
M65T18M	2012305	65	53.62	47.62	14.50	22.75	4.12	6.00	4.44	5/8, 3/4, 7/8, 1	—	—	1100
M65T18H	2012306	65	53.62	47.62	16.50	22.75	4.12	6.00	4.44	5/8, 3/4, 7/8, 1	—	—	1300
M65T20L	2012307	65	54.12	48.12	10.38	24.75	4.12	6.00	4.44	3/4, 7/8, 1, 1-1/8	—	—	995
M65T20M	2012311	65	54.12	48.12	14.88	24.75	4.12	6.00	4.44	3/4, 7/8, 1, 1-1/8	—	—	1300
M65T20H	2012315	65	54.12	48.12	18.88	24.75	4.12	6.00	4.44	3/4, 7/8, 1, 1-1/8	—	—	1635
M65T24L	2012316	65	59.12	53.12	10.38	28.75	4.12	6.00	4.44	7/8, 1, 1-1/8, 1-1/4	—	—	1255
M65T24M	2012317	65	59.12	53.12	18.12	28.75	4.12	6.00	4.44	7/8, 1, 1-1/8, 1-1/4	—	—	1890
M65T24H	2012318	65	59.12	53.12	22.12	28.75	4.12	6.00	4.44	7/8, 1, 1-1/8, 1-1/4	—	—	2365
M65Q16L	2012312	65	49.88	43.88	13.31	20.25	4.12	6.00	4.44	9/16, 5/8, 3/4, 7/8	—	—	905
M65Q16M	2012313	65	49.88	43.88	17.69	20.25	4.12	6.00	4.44	9/16, 5/8, 3/4, 7/8	—	—	1030
M65Q16H	2012314	65	49.88	43.88	20.19	20.25	4.12	6.00	4.44	9/16, 5/8, 3/4, 7/8	—	—	1220
M65Q18L	2012340	65	53.62	47.62	13.31	22.75	4.12	6.00	4.44	5/8, 3/4, 7/8, 1	—	—	1060
M65Q18M	2012341	65	53.62	47.62	17.44	22.75	4.12	6.00	4.44	5/8, 3/4, 7/8, 1	—	—	1215
M65Q18H	2012342	65	53.62	47.62	19.44	22.75	4.12	6.00	4.44	5/8, 3/4, 7/8, 1	—	—	1430
M65Q20L	2012319	65	54.12	48.12	13.31	24.75	4.12	6.00	4.44	3/4, 7/8, 1, 1-1/8	—	—	1140
M65Q20M	2012323	65	54.12	48.12	17.81	24.75	4.12	6.00	4.44	3/4, 7/8, 1, 1-1/8	—	—	1490
M65Q20H	2012327	65	54.12	48.12	21.81	24.75	4.12	6.00	4.44	3/4, 7/8, 1, 1-1/8	—	—	1855
M65Q24L	2012328	65	59.12	53.12	13.31	28.75	4.12	6.00	4.44	7/8, 1, 1-1/8, 1-1/4	—	—	1452
M65Q24M	2012329	65	59.12	53.12	21.06	28.75	4.12	6.00	4.44	7/8, 1, 1-1/8, 1-1/4	—	—	2120
M65Q24H	2012330	65	59.12	53.12	25.06	28.75	4.12	6.00	4.44	7/8, 1, 1-1/8, 1-1/4	—	—	2600
M65QN16L	2012331	65	56.88	45.88	17.50	20.25	4.12	6.00	4.44	9/16, 5/8, 3/4, 7/8	1.50	1.41	885
M65QN16M	2012335	65	56.88	45.88	21.88	20.25	4.12	6.00	4.44	9/16, 5/8, 3/4, 7/8	1.50	1.41	1047
M65QN16H	2012339	65	56.88	45.88	24.38	20.25	4.12	6.00	4.44	9/16, 5/8, 3/4, 7/8	1.50	1.41	1200
M65QN18L	2012343	65	58.62	47.62	17.50	22.75	4.12	6.00	4.44	5/8, 3/4, 7/8, 1	1.50	1.41	1380
M65QN18M	2012347	65	58.62	47.62	21.62	22.75	4.12	6.00	4.44	5/8, 3/4, 7/8, 1	1.50	1.41	1600
M65QN18H	2012351	65	58.62	47.62	23.62	22.75	4.12	6.00	4.44	5/8, 3/4, 7/8, 1	1.50	1.41	1748
M65QN20L	2012355	65	59.12	48.12	17.50	24.75	4.12	6.00	4.44	3/4, 7/8, 1, 1-1/8	1.50	1.41	1565
M65QN20M	2012359	65	59.12	48.12	22.00	24.75	4.12	6.00	4.44	3/4, 7/8, 1, 1-1/8	1.50	1.41	1860
M65QN20H	2012363	65	59.12	48.12	26.00	24.75	4.12	6.00	4.44	3/4, 7/8, 1, 1-1/8	1.50	1.41	2210
M65QN24L	2012364	65	62.62	51.62	17.50	28.75	4.12	6.00	4.44	7/8, 1, 1-1/8, 1-1/4	1.50	1.41	1831
M65QN24M	2012368	65	62.62	51.62	25.25	28.75	4.12	6.00	4.44	7/8, 1, 1-1/8, 1-1/4	1.50	1.41	2536
M65QN24H	2012372	65	62.62	51.62	29.25	28.75	4.12	6.00	4.44	7/8, 1, 1-1/8, 1-1/4	1.50	1.41	2999
M65SX16L	2012352	65	56.88	45.88	19.53	20.25	4.12	6.00	4.44	9/16, 5/8, 3/4, 7/8	1.50	2.06	1170
M65SX16M	2012353	65	56.88	45.88	23.91	20.25	4.12	6.00	4.44	9/16, 5/8, 3/4, 7/8	1.50	2.06	1335
M65SX16H	2012354	65	56.88	45.88	26.41	20.25	4.12	6.00	4.44	9/16, 5/8, 3/4, 7/8	1.50	2.06	1485
M65SX18L	2012356	65	58.62	47.62	19.53	22.75	4.12	6.00	4.44	5/8, 3/4, 7/8, 1	1.50	2.06	1410
M65SX18M	2012357	65	58.62	47.62	23.66	22.75	4.12	6.00	4.44	5/8, 3/4, 7/8, 1	1.50	2.06	1650

McKissick  
Blocks



## 380 Series Crane Blocks

Model No.	Inquiry Stock No.	Working Load Limit (Tons) †	A Overall Length (in)	B Net Length (in)	E Thickness (in)	F Width (in)	H Throat Opening with Flapper (in)	J Hook Thickness (in)	K Hook Width (in)	Standard Wireline Sizes (in)*	Dead End ‡		Weight Each (lb)
											T Thickness (in)	U Pin Hole (in)	
M65SX18H	2012358	65	58.62	47.62	25.66	22.75	4.12	6.00	4.44	5/8, 3/4, 7/8, 1	1.50	2.06	1798
M65SX20L	2012367	65	59.12	48.12	19.53	24.75	4.12	6.00	4.44	3/4, 7/8, 1, 1-1/8	1.50	2.06	1624
M65SX20M	2012371	65	59.12	48.12	24.03	24.75	4.12	6.00	4.44	3/4, 7/8, 1, 1-1/8	1.50	2.06	1920
M65SX20H	2012375	65	59.12	48.12	28.03	24.75	4.12	6.00	4.44	3/4, 7/8, 1, 1-1/8	1.50	2.06	2272
<b>70 Tons</b>													
M70D24L	2012379	70	64.44	57.75	11.09	28.75	5.38	6.69	4.25	7/8, 1, 1-1/8, 1-1/4	—	—	1522
M70D24M	2012383	70	64.44	57.75	18.84	28.75	5.38	6.69	4.25	7/8, 1, 1-1/8, 1-1/4	—	—	2190
M70D24H	2012387	70	64.44	57.75	22.84	28.75	5.38	6.69	4.25	7/8, 1, 1-1/8, 1-1/4	—	—	2670
M70T18L	2012391	70	58.94	52.25	11.12	22.75	5.38	6.69	4.25	5/8, 3/4, 7/8, 1	—	—	1260
M70T18M	2012395	70	58.94	52.25	15.25	22.75	5.38	6.69	4.25	5/8, 3/4, 7/8, 1	—	—	1500
M70T18H	2012399	70	58.94	52.25	17.25	22.75	5.38	6.69	4.25	5/8, 3/4, 7/8, 1	—	—	1650
M70T20L	2012403	70	60.94	54.25	11.12	24.75	5.38	6.69	4.25	3/4, 7/8, 1, 1-1/8	—	—	1414
M70T20M	2012407	70	60.94	54.25	15.62	24.75	5.38	6.69	4.25	3/4, 7/8, 1, 1-1/8	—	—	1710
M70T20H	2012411	70	60.94	54.25	19.25	24.75	5.38	6.69	4.25	3/4, 7/8, 1, 1-1/8	—	—	2062
M70T24L	2012415	70	64.44	57.75	11.12	28.75	5.38	6.69	4.25	7/8, 1, 1-1/8, 1-1/4	—	—	1642
M70T24M	2012419	70	64.44	57.75	18.88	28.75	5.38	6.69	4.25	7/8, 1, 1-1/8, 1-1/4	—	—	2292
M70T24H	2012423	70	64.44	57.75	22.88	28.75	5.38	6.69	4.25	7/8, 1, 1-1/8, 1-1/4	—	—	2772
M70Q16L	2012427	70	57.19	50.50	13.31	20.25	5.38	6.69	4.25	9/16, 5/8, 3/4, 7/8	—	—	1175
M70Q16M	2012431	70	57.19	50.50	17.69	20.25	5.38	6.69	4.25	9/16, 5/8, 3/4, 7/8	—	—	1340
M70Q16H	2012435	70	57.19	50.50	20.25	20.25	5.38	6.69	4.25	9/16, 5/8, 3/4, 7/8	—	—	1491
M70Q18L	2012439	70	58.94	52.25	13.31	22.75	5.38	6.69	4.25	5/8, 3/4, 7/8, 1	—	—	1300
M70Q18M	2012443	70	58.94	52.25	17.44	22.75	5.38	6.69	4.25	5/8, 3/4, 7/8, 1	—	—	1540
M70Q18H	2012447	70	58.94	52.25	19.44	22.75	5.38	6.69	4.25	5/8, 3/4, 7/8, 1	—	—	1688
M70Q20L	2012451	70	60.94	54.25	13.31	24.75	5.38	6.69	4.25	3/4, 7/8, 1, 1-1/8	—	—	1436
M70Q20M	2012455	70	60.94	54.25	17.81	24.75	5.38	6.69	4.25	3/4, 7/8, 1, 1-1/8	—	—	1732
M70Q20H	2012459	70	60.94	54.25	21.81	24.75	5.38	6.69	4.25	3/4, 7/8, 1, 1-1/8	—	—	2084
M70Q24L	2012463	70	64.44	57.75	13.31	28.75	5.38	6.69	4.25	7/8, 1, 1-1/8, 1-1/4	—	—	1718
M70Q24M	2012467	70	64.44	57.75	21.06	28.75	5.38	6.69	4.25	7/8, 1, 1-1/8, 1-1/4	—	—	2386
M70Q24H	2012471	70	64.44	57.75	25.06	28.75	5.38	6.69	4.25	7/8, 1, 1-1/8, 1-1/4	—	—	2866
M70QN16L	2012475	70	64.56	50.50	18.25	20.25	5.38	6.69	4.25	9/16, 5/8, 3/4, 7/8	1.50	1.66	1340
M70QN16M	2012479	70	64.56	50.50	22.62	20.25	5.38	6.69	4.25	9/16, 5/8, 3/4, 7/8	1.50	1.66	1506
M70QN16H	2012483	70	64.56	50.50	25.12	20.25	5.38	6.69	4.25	9/16, 5/8, 3/4, 7/8	1.50	1.66	1656
M70QN18L	2012487	70	63.31	52.25	18.25	22.75	5.38	6.69	4.25	5/8, 3/4, 7/8, 1	1.50	1.66	1675
M70QN18M	2012491	70	63.31	52.25	22.38	22.75	5.38	6.69	4.25	5/8, 3/4, 7/8, 1	1.50	1.66	1895
M70QN18H	2012495	70	63.31	52.25	24.38	22.75	5.38	6.69	4.25	5/8, 3/4, 7/8, 1	1.50	1.66	2093
M70QN20L	2012499	70	65.94	54.25	18.25	24.75	5.38	6.69	4.25	3/4, 7/8, 1, 1-1/8	1.50	2.06	1889
M70QN20M	2012503	70	65.94	54.25	22.75	24.75	5.38	6.69	4.25	3/4, 7/8, 1, 1-1/8	1.50	2.06	2185
M70QN20H	2012507	70	65.94	54.25	26.75	24.75	5.38	6.69	4.25	3/4, 7/8, 1, 1-1/8	1.50	2.06	2537
M70QN24L	2012511	70	69.44	57.75	18.25	28.75	5.38	6.69	4.25	7/8, 1, 1-1/8, 1-1/4	1.50	2.06	2232
M70QN24M	2012515	70	69.44	57.75	26.00	28.75	5.38	6.69	4.25	7/8, 1, 1-1/8, 1-1/4	1.50	2.06	2900
M70QN24H	2012519	70	69.44	57.75	30.00	28.75	5.38	6.69	4.25	7/8, 1, 1-1/8, 1-1/4	1.50	2.06	3380
M70SX16L	2012523	70	61.56	50.50	20.41	20.25	5.38	6.69	4.25	9/16, 5/8, 3/4, 7/8	1.50	1.66	1544
M70SX16M	2012527	70	61.56	50.50	24.78	20.25	5.38	6.69	4.25	9/16, 5/8, 3/4, 7/8	1.50	1.66	1710
M70SX16H	2012531	70	61.56	50.50	27.28	20.25	5.38	6.69	4.25	9/16, 5/8, 3/4, 7/8	1.50	1.66	1860
M70SX18L	2012535	70	63.94	52.25	20.41	22.75	5.38	6.69	4.25	5/8, 3/4, 7/8, 1	1.50	2.06	1915
M70SX18M	2012539	70	63.94	52.25	24.53	22.75	5.38	6.69	4.25	5/8, 3/4, 7/8, 1	1.50	2.06	2135
M70SX18H	2012543	70	63.94	52.25	26.53	22.75	5.38	6.69	4.25	5/8, 3/4, 7/8, 1	1.50	2.06	2283
M70SX20L	2012547	70	65.94	54.25	20.41	24.75	5.38	6.69	4.25	3/4, 7/8, 1, 1-1/8	1.50	2.06	2015
M70SX20M	2012551	70	65.94	54.25	24.91	24.75	5.38	6.69	4.25	3/4, 7/8, 1, 1-1/8	1.50	2.06	2311
M70SX20H	2012555	70	65.94	54.25	28.91	24.75	5.38	6.69	4.25	3/4, 7/8, 1, 1-1/8	1.50	2.06	2663
<b>75 Tons</b>													
M75D24L	2012559	75	64.44	57.75	11.09	28.75	5.38	6.69	4.25	7/8, 1, 1-1/8, 1-1/4	—	—	1522
M75D24M	2012563	75	64.44	57.75	18.84	28.75	5.38	6.69	4.25	7/8, 1, 1-1/8, 1-1/4	—	—	2190
M75D24H	2012567	75	64.44	57.75	22.84	28.75	5.38	6.69	4.25	7/8, 1, 1-1/8, 1-1/4	—	—	2670
M75T20L	2012571	75	60.94	54.25	11.12	24.75	5.38	6.69	4.25	3/4, 7/8, 1, 1-1/8	—	—	1414
M75T20M	2012575	75	60.94	54.25	15.62	24.75	5.38	6.69	4.25	3/4, 7/8, 1, 1-1/8	—	—	1710
M75T20H	2012579	75	60.94	54.25	19.62	24.75	5.38	6.69	4.25	3/4, 7/8, 1, 1-1/8	—	—	2062
M75T24L	2012583	75	64.44	57.75	11.12	28.75	5.38	6.69	4.25	7/8, 1, 1-1/8, 1-1/4	—	—	1624
M75T24M	2012587	75	64.44	57.75	18.88	28.75	5.38	6.69	4.25	7/8, 1, 1-1/8, 1-1/4	—	—	2290
M75T24H	2012591	75	64.44	57.75	22.88	28.75	5.38	6.69	4.25	7/8, 1, 1-1/8, 1-1/4	—	—	2772
M75Q16L	2012596	75	57.19	50.50	13.31	20.25	5.38	6.69	4.25	9/16, 5/8, 3/4, 7/8	—	—	1175
M75Q16M	2012600	75	57.19	50.50	17.69	20.25	5.38	6.69	4.25	9/16, 5/8, 3/4, 7/8	—	—	1341
M75Q16H	2012604	75	57.19	50.50	20.19	20.25	5.38	6.69	4.25	9/16, 5/8, 3/4, 7/8	—	—	1491
M75Q18L	2012595	75	58.94	52.25	13.31	22.75	5.38	6.69	4.25	5/8, 3/4, 7/8, 1	—	—	1300
M75Q18M	2012599	75	58.94	52.25	17.44	22.75	5.38	6.69	4.25	5/8, 3/4, 7/8, 1	—	—	1540
M75Q18H	2012603	75	58.94	52.25	19.44	22.75	5.38	6.69	4.25	5/8, 3/4, 7/8, 1	—	—	1688
M75Q20L	2012607	75	60.94	54.25	13.31	24.75	5.38	6.69	4.25	3/4, 7/8, 1, 1-1/8	—	—	1436
M75Q20M	2012611	75	60.94	54.25	17.81	24.75	5.38	6.69	4.25	3/4, 7/8, 1, 1-1/8	—	—	1732
M75Q20H	2012615	75	60.94	54.25	21.81	24.75	5.38	6.69	4.25	3/4, 7/8, 1, 1-1/8	—	—	2084
M75Q24L	2012619	75	64.44	57.75	13.31	28.75	5.38	6.69	4.25	7/8, 1, 1-1/8, 1-1/4	—	—	1718

# McKissick® 380 Series Crane Blocks

## 380 Series Crane Blocks

Model No.	Inquiry Stock No.	Working Load Limit (Tons) †	A Overall Length (in)	B Net Length (in)	E Thickness (in)	F Width (in)	H Throat Opening with Flapper (in)	J Hook Thickness (in)	K Hook Width (in)	Standard Wireline Sizes (in)*	Dead End ‡		Weight Each (lb)
											T Thickness (in)	U Pin Hole (in)	
M75Q24M	2012623	75	64.44	57.75	21.06	28.75	5.38	6.69	4.25	7/8, 1, 1-1/8, 1-1/4	—	—	2386
M75Q24H	2012627	75	64.44	57.75	25.06	28.75	5.38	6.69	4.25	7/8, 1, 1-1/8, 1-1/4	—	—	2866
M75QN16L	2012631	75	61.56	50.50	18.25	20.25	5.38	6.69	4.25	9/16, 5/8, 3/4, 7/8	1.50	1.66	1340
M75QN16M	2012635	75	61.56	50.50	22.62	20.25	5.38	6.69	4.25	9/16, 5/8, 3/4, 7/8	1.50	1.66	1420
M75QN16H	2012639	75	61.56	50.50	25.12	20.25	5.38	6.69	4.25	9/16, 5/8, 3/4, 7/8	1.50	1.66	1656
M75QN18L	2012632	75	63.31	52.25	18.25	22.25	5.38	6.69	4.25	5/8, 3/4, 7/8, 1	1.50	1.66	1675
M75QN18M	2012636	75	63.31	52.25	22.38	22.25	5.38	6.69	4.25	5/8, 3/4, 7/8, 1	1.50	1.66	1895
M75QN18H	2012640	75	63.31	52.25	24.38	22.75	5.38	6.69	4.25	5/8, 3/4, 7/8, 1	1.50	1.66	2043
M75QN20L	2012643	75	65.94	54.25	18.25	24.75	5.38	6.69	4.25	3/4, 7/8, 1, 1-1/8	1.50	2.06	1889
M75QN20M	2012647	75	65.94	54.25	22.75	24.75	5.38	6.69	4.25	3/4, 7/8, 1, 1-1/8	1.50	2.06	2185
M75QN20H	2012651	75	65.94	54.25	26.75	24.75	5.38	6.69	4.25	3/4, 7/8, 1, 1-1/8	1.50	2.06	2537
M75QN24L	2012655	75	64.44	57.75	18.25	28.75	5.38	6.69	4.25	7/8, 1, 1-1/8, 1-1/4	1.50	2.06	2232
M75QN24M	2012659	75	64.44	57.75	26.00	28.75	5.38	6.69	4.25	7/8, 1, 1-1/8, 1-1/4	1.50	2.06	2900
M75QN24H	2012663	75	64.44	57.75	30.00	28.75	5.38	6.69	4.25	7/8, 1, 1-1/8, 1-1/4	1.50	2.06	3380
M75SX16L	2012668	75	61.56	50.50	20.41	20.25	5.38	6.69	4.25	9/16, 5/8, 3/4, 7/8	1.50	2.06	1544
M75SX16M	2012672	75	61.56	50.50	24.78	20.25	5.38	6.69	4.25	9/16, 5/8, 3/4, 7/8	1.50	2.06	1710
M75SX16H	2012676	75	61.56	50.50	27.28	20.25	5.38	6.69	4.25	9/16, 5/8, 3/4, 7/8	1.50	2.06	1860
M75SX18L	2012667	75	63.94	52.25	20.41	22.75	5.38	6.69	4.25	5/8, 3/4, 7/8, 1	1.50	2.06	1915
M75SX18M	2012671	75	63.94	52.25	24.53	22.75	5.38	6.69	4.25	5/8, 3/4, 7/8, 1	1.50	2.06	2135
M75SX18H	2012675	75	63.94	52.25	26.53	22.75	5.38	6.69	4.25	5/8, 3/4, 7/8, 1	1.50	2.06	2283
M75SX20L	2012679	75	65.94	54.25	20.41	24.75	5.38	6.69	4.25	3/4, 7/8, 1, 1-1/8	1.50	2.06	2015
M75SX20M	2012683	75	65.94	54.25	24.91	24.75	5.38	6.69	4.25	3/4, 7/8, 1, 1-1/8	1.50	2.06	2311
M75SX20H	2012687	75	65.94	54.25	28.91	24.75	5.38	6.69	4.25	3/4, 7/8, 1, 1-1/8	1.50	2.06	2663
<b>80 Tons</b>													
M80D24L	2012691	80	64.44	57.75	11.09	28.75	5.38	6.69	4.25	7/8, 1, 1-1/8, 1-1/4	—	—	1522
M80D24M	2012695	80	64.44	57.75	18.84	28.75	5.38	6.69	4.25	7/8, 1, 1-1/8, 1-1/4	—	—	2190
M80D24H	2012699	80	64.44	57.75	22.84	28.75	5.38	6.69	4.25	7/8, 1, 1-1/8, 1-1/4	—	—	2670
M80T20L	2012703	80	60.94	54.25	11.12	24.75	5.38	6.69	4.25	3/4, 7/8, 1, 1-1/8	—	—	1414
M80T20M	2012707	80	60.94	54.25	15.62	24.75	5.38	6.69	4.25	3/4, 7/8, 1, 1-1/8	—	—	1710
M80T20H	2012711	80	60.94	54.25	19.62	24.75	5.38	6.69	4.25	3/4, 7/8, 1, 1-1/8	—	—	2062
M80T24L	2012715	80	64.44	57.75	11.12	28.75	5.38	6.69	4.25	7/8, 1, 1-1/8, 1-1/4	—	—	1624
M80T24M	2012719	80	64.44	57.75	18.88	28.75	5.38	6.69	4.25	7/8, 1, 1-1/8, 1-1/4	—	—	2292
M80T24H	2012723	80	64.44	57.75	22.88	28.75	5.38	6.69	4.25	7/8, 1, 1-1/8, 1-1/4	—	—	2772
M80Q16L	2012727	80	57.19	50.50	13.31	20.25	5.38	6.69	4.25	9/16, 5/8, 3/4, 7/8	—	—	1175
M80Q16M	2012731	80	57.19	50.50	17.69	20.25	5.38	6.69	4.25	9/16, 5/8, 3/4, 7/8	—	—	1341
M80Q16H	2012735	80	57.19	50.50	20.19	20.25	5.38	6.69	4.25	9/16, 5/8, 3/4, 7/8	—	—	1491
M80Q18L	2012739	80	58.94	52.25	13.31	22.75	5.38	6.69	4.25	5/8, 3/4, 7/8, 1	—	—	1300
M80Q18M	2012743	80	58.94	52.25	17.44	22.75	5.38	6.69	4.25	5/8, 3/4, 7/8, 1	—	—	1540
M80Q18H	2012747	80	58.94	52.25	19.44	22.75	5.38	6.69	4.25	5/8, 3/4, 7/8, 1	—	—	1688
M80Q20L	2012751	80	60.94	54.25	13.31	24.75	5.38	6.69	4.25	3/4, 7/8, 1, 1-1/8	—	—	1436
M80Q20M	2012755	80	60.94	54.25	17.81	24.75	5.38	6.69	4.25	3/4, 7/8, 1, 1-1/8	—	—	1732
M80Q20H	2012759	80	60.94	54.25	21.81	24.75	5.38	6.69	4.25	3/4, 7/8, 1, 1-1/8	—	—	2084
M80Q24L	2012763	80	64.44	57.75	13.31	28.75	5.38	6.69	4.25	7/8, 1, 1-1/8, 1-1/4	—	—	1718
M80Q24M	2012767	80	64.44	57.75	21.06	28.75	5.38	6.69	4.25	7/8, 1, 1-1/8, 1-1/4	—	—	2386
M80Q24H	2012771	80	64.44	57.75	25.06	28.75	5.38	6.69	4.25	7/8, 1, 1-1/8, 1-1/4	—	—	2866
M80QN16L	2012775	80	61.56	50.50	18.25	20.25	5.38	6.69	4.25	9/16, 5/8, 3/4, 7/8	1.50	1.66	1340
M80QN16M	2012779	80	61.56	50.50	22.62	20.25	5.38	6.69	4.25	9/16, 5/8, 3/4, 7/8	1.50	1.66	1506
M80QN16H	2012783	80	61.56	50.50	25.12	20.25	5.38	6.69	4.25	9/16, 5/8, 3/4, 7/8	1.50	1.66	1656
M80QN18L	2012787	80	63.31	52.25	18.25	22.75	5.38	6.69	4.25	5/8, 3/4, 7/8, 1	1.50	1.66	1675
M80QN18M	2012791	80	63.31	52.25	22.38	22.75	5.38	6.69	4.25	5/8, 3/4, 7/8, 1	1.50	1.66	1895
M80QN18H	2012795	80	63.31	52.25	24.38	22.75	5.38	6.69	4.25	5/8, 3/4, 7/8, 1	1.50	1.66	2043
M80QN20L	2012799	80	65.94	54.25	18.25	24.75	5.38	6.69	4.25	3/4, 7/8, 1, 1-1/8	1.50	2.06	1889
M80QN20M	2012803	80	65.94	54.25	22.75	24.75	5.38	6.69	4.25	3/4, 7/8, 1, 1-1/8	1.50	2.06	2185
M80QN20H	2012807	80	65.94	54.25	26.75	24.75	5.38	6.69	4.25	3/4, 7/8, 1, 1-1/8	1.50	2.06	2537
M80QN24L	2012811	80	69.44	57.75	18.25	28.75	5.38	6.69	4.25	7/8, 1, 1-1/8, 1-1/4	1.50	2.06	2232
M80QN24M	2012815	80	69.44	57.75	26.00	28.75	5.38	6.69	4.25	7/8, 1, 1-1/8, 1-1/4	1.50	2.06	2900
M80QN24H	2012819	80	69.44	57.75	30.00	28.75	5.38	6.69	4.25	7/8, 1, 1-1/8, 1-1/4	1.50	2.06	3380
M80SX16L	2012823	80	61.56	50.50	20.41	20.25	5.38	6.69	4.25	9/16, 5/8, 3/4, 7/8	1.50	2.06	1544
M80SX16M	2012827	80	61.56	50.50	24.78	20.25	5.38	6.69	4.25	9/16, 5/8, 3/4, 7/8	1.50	2.06	1710
M80SX16H	2012831	80	61.56	50.50	27.28	20.25	5.38	6.69	4.25	9/16, 5/8, 3/4, 7/8	1.50	2.06	1860
M80SX18L	2012835	80	63.94	52.25	20.41	22.75	5.38	6.69	4.25	5/8, 3/4, 7/8, 1	1.50	2.06	1915
M80SX18M	2012839	80	63.94	52.25	24.53	22.75	5.38	6.69	4.25	5/8, 3/4, 7/8, 1	1.50	2.06	2135
M80SX18H	2012843	80	63.94	52.25	26.53	22.75	5.38	6.69	4.25	5/8, 3/4, 7/8, 1	1.50	2.06	2283
M80SX20L	2012847	80	65.94	54.25	20.41	24.75	5.38	6.69	4.25	3/4, 7/8, 1, 1-1/8	1.50	2.06	2015
M80SX20M	2012851	80	65.94	54.25	24.91	24.75	5.38	6.69	4.25	3/4, 7/8, 1, 1-1/8	1.50	2.06	2311
M80SX20H	2012855	80	65.94	54.25	28.91	24.75	5.38	6.69	4.25	3/4, 7/8, 1, 1-1/8	1.50	2.06	2663
<b>90 Tons</b>													
M90T24L	2012859	90	68.5	59.91	11.66	28.75	4.5	8.59	5.5	7/8, 1, 1-1/8, 1-1/4	—	—	1932
M90T24M	2012863	90	68.5	59.91	19.41	28.75	4.5	8.59	5.5	7/8, 1, 1-1/8, 1-1/4	—	—	2600
M90T24H	2012867	90	68.5	59.91	23.41	28.75	4.5	8.59	5.5	7/8, 1, 1-1/8, 1-1/4	—	—	3080

McKissick Blocks

## 380 Series Crane Blocks

Model No.	Inquiry Stock No.	Working Load Limit (Tons) †	A Overall Length (in)	B Net Length (in)	E Thickness (in)	F Width (in)	H Throat Opening with Flapper (in)	J Hook Thickness (in)	K Hook Width (in)	Standard Wireline Sizes (in)*	Dead End ‡		Weight Each (lb)
											T Thickness (in)	U Pin Hole (in)	
M90Q20L	2012871	90	64.00	55.41	13.56	24.75	4.50	8.59	5.50	3/4, 7/8, 1, 1-1/8	—	—	1780
M90Q20M	2012875	90	64.00	55.41	18.06	24.75	4.50	8.59	5.50	3/4, 7/8, 1, 1-1/8	—	—	2075
M90Q20H	2012879	90	64.00	55.41	22.06	24.75	4.50	8.59	5.50	3/4, 7/8, 1, 1-1/8	—	—	2427
M90Q24L	2012883	90	68.50	59.91	13.81	28.75	4.50	8.59	5.50	7/8, 1, 1-1/8, 1-1/4	—	—	2068
M90Q24M	2012887	90	68.50	59.91	21.56	28.75	4.50	8.59	5.50	7/8, 1, 1-1/8, 1-1/4	—	—	2700
M90Q24H	2012891	90	68.50	59.91	25.56	28.75	4.50	8.59	5.50	7/8, 1, 1-1/8, 1-1/4	—	—	3180
M90QN18L	2012904	90	67.00	53.91	18.25	22.75	4.50	8.59	5.50	5/8, 3/4, 7/8, 1	1.50	2.28	1930
M90QN18M	2012908	90	67.00	53.91	22.38	22.75	4.50	8.59	5.50	5/8, 3/4, 7/8, 1	1.50	2.28	2170
M90QN18H	2012912	90	67.00	53.91	24.38	22.75	4.50	8.59	5.50	5/8, 3/4, 7/8, 1	1.50	2.28	2318
M90QN20L	2012895	90	69.00	55.41	18.25	24.75	4.50	8.59	5.50	3/4, 7/8, 1, 1-1/8	1.50	2.28	2044
M90QN20M	2012899	90	69.00	55.41	22.75	24.75	4.50	8.59	5.50	3/4, 7/8, 1, 1-1/8	1.50	2.28	2340
M90QN20H	2012903	90	69.00	55.41	26.75	24.75	4.50	8.59	5.50	3/4, 7/8, 1, 1-1/8	1.50	2.28	2692
M90QN24L	2012907	90	73.00	59.41	18.25	28.75	4.50	8.59	5.50	7/8, 1, 1-1/8, 1-1/4	1.50	2.28	2477
M90QN24M	2012911	90	73.00	59.41	26.00	28.75	4.50	8.59	5.50	7/8, 1, 1-1/8, 1-1/4	1.50	2.28	3145
M90QN24H	2012915	90	73.00	59.41	30.00	28.75	4.50	8.59	5.50	7/8, 1, 1-1/8, 1-1/4	1.50	2.28	3625
M90SX18L	2012919	90	67.00	53.41	20.41	22.75	4.50	8.59	5.50	5/8, 3/4, 7/8, 1	1.50	2.06	2080
M90SX18M	2012923	90	67.00	53.41	24.53	22.75	4.50	8.59	5.50	5/8, 3/4, 7/8, 1	1.50	2.06	2300
M90SX18H	2012927	90	67.00	53.41	26.53	22.75	4.50	8.59	5.50	5/8, 3/4, 7/8, 1	1.50	2.06	2448
M90SX20L	2012931	90	69.00	55.41	20.41	24.75	4.50	8.59	5.50	3/4, 7/8, 1, 1-1/8	1.50	2.06	2165
M90SX20M	2012935	90	69.00	55.41	24.91	24.75	4.50	8.59	5.50	3/4, 7/8, 1, 1-1/8	1.50	2.06	2462
M90SX20H	2012939	90	69.00	55.41	28.91	24.75	4.50	8.59	5.50	3/4, 7/8, 1, 1-1/8	1.50	2.06	2816
M90SX24L	2012943	90	73.00	59.41	20.41	28.75	4.50	8.59	5.50	7/8, 1, 1-1/8, 1-1/4	1.50	2.06	2615
M90SX24M	2012947	90	73.00	59.41	28.16	28.75	4.50	8.59	5.50	7/8, 1, 1-1/8, 1-1/4	1.50	2.06	3248
M90SX24H	2012952	90	73.00	59.41	32.16	28.75	4.50	8.59	5.50	7/8, 1, 1-1/8, 1-1/4	1.50	2.06	3730
<b>100 Tons</b>													
M100T24L	2012860	100	68.50	59.91	11.66	28.75	4.50	8.59	5.50	7/8, 1, 1-1/8, 1-1/4	—	—	1932
M100T24M	2012864	100	68.50	59.91	19.41	28.75	4.50	8.59	5.50	7/8, 1, 1-1/8, 1-1/4	—	—	2600
M100T24H	2012868	100	68.50	59.91	23.41	28.75	4.50	8.59	5.50	7/8, 1, 1-1/8, 1-1/4	—	—	3080
M100Q20L	2012967	100	64.00	55.41	13.56	24.75	4.50	8.59	5.50	3/4, 7/8, 1, 1-1/8	—	—	1780
M100Q20M	2012971	100	64.00	55.41	18.06	24.75	4.50	8.59	5.50	3/4, 7/8, 1, 1-1/8	—	—	2075
M100Q20H	2012975	100	64.00	55.41	22.06	24.75	4.50	8.59	5.50	3/4, 7/8, 1, 1-1/8	—	—	2427
M100Q24L	2012979	100	68.50	59.91	13.81	28.75	4.50	8.59	5.50	7/8, 1, 1-1/8, 1-1/4	—	—	2068
M100Q24M	2012983	100	68.50	59.91	21.56	28.75	4.50	8.59	5.50	7/8, 1, 1-1/8, 1-1/4	—	—	2700
M100Q24H	2012987	100	68.50	59.91	25.56	28.75	4.50	8.59	5.50	7/8, 1, 1-1/8, 1-1/4	—	—	3180
M100QN18L	2012991	100	67.00	53.91	18.25	22.75	4.50	8.59	5.50	5/8, 3/4, 7/8, 1	1.50	2.28	1930
M100QN18M	2012995	100	67.00	53.91	22.38	22.75	4.50	8.59	5.50	5/8, 3/4, 7/8, 1	1.50	2.28	2170
M100QN18H	2012999	100	67.00	53.91	24.38	22.75	4.50	8.59	5.50	5/8, 3/4, 7/8, 1	1.50	2.28	2318
M100QN20L	2013003	100	69.00	55.41	18.25	24.75	4.50	8.59	5.50	3/4, 7/8, 1, 1-1/8	1.50	2.28	2044
M100QN20M	2013007	100	69.00	55.41	22.75	24.75	4.50	8.59	5.50	3/4, 7/8, 1, 1-1/8	1.50	2.28	2340
M100QN20H	2013011	100	69.00	55.41	26.75	24.75	4.50	8.59	5.50	3/4, 7/8, 1, 1-1/8	1.50	2.28	2692
M100QN24L	2013015	100	73.00	59.41	18.25	28.75	4.50	8.59	5.50	7/8, 1, 1-1/8, 1-1/4	1.50	2.28	2477
M100QN24M	2013019	100	73.00	59.41	26.00	28.75	4.50	8.59	5.50	7/8, 1, 1-1/8, 1-1/4	1.50	2.28	3145
M100QN24H	2013023	100	73.00	59.41	30.00	28.75	4.50	8.59	5.50	7/8, 1, 1-1/8, 1-1/4	1.50	2.28	3625
M100SX18L	2013027	100	67.00	53.41	20.41	22.75	4.50	8.59	5.50	5/8, 3/4, 7/8, 1	1.50	2.06	2080
M100SX18M	2013031	100	67.00	53.41	24.53	22.75	4.50	8.59	5.50	5/8, 3/4, 7/8, 1	1.50	2.06	2300
M100SX18H	2013035	100	67.00	53.41	26.53	22.75	4.50	8.59	5.50	5/8, 3/4, 7/8, 1	1.50	2.06	2448
M100SX20L	2013039	100	69.00	55.41	20.41	24.75	4.50	8.59	5.50	3/4, 7/8, 1, 1-1/8	1.50	2.06	2165
M100SX20M	2013043	100	69.00	55.41	24.91	24.75	4.50	8.59	5.50	3/4, 7/8, 1, 1-1/8	1.50	2.06	2462
M100SX20H	2013047	100	69.00	55.41	28.91	24.75	4.50	8.59	5.50	3/4, 7/8, 1, 1-1/8	1.50	2.06	2816
M100SX24L	2013051	100	73.00	59.41	20.41	28.75	4.50	8.59	5.50	7/8, 1, 1-1/8, 1-1/4	1.50	2.06	2615
M100SX24M	2013055	100	73.00	59.41	28.16	28.75	4.50	8.59	5.50	7/8, 1, 1-1/8, 1-1/4	1.50	2.06	3248
M100SX24H	2013059	100	73.00	59.41	32.16	28.75	4.50	8.59	5.50	7/8, 1, 1-1/8, 1-1/4	1.50	2.06	3730
<b>115 Tons</b>													
M115Q24L	2013075	115	72.00	62.88	16.44	28.75	4.50	9.12	6.00	7/8, 1, 1-1/8, 1-1/4	-	-	2753
M115Q24M	2013079	115	72.00	62.88	24.19	28.75	4.50	9.12	6.00	7/8, 1, 1-1/8, 1-1/4	-	-	3385
M115Q24H	2013083	115	72.00	62.88	28.19	28.75	4.50	9.12	6.00	7/8, 1, 1-1/8, 1-1/4	-	-	3865
M115QN24L	2013087	115	77.25	62.88	20.25	28.75	4.50	9.12	6.00	7/8, 1, 1-1/8, 1-1/4	1.75	2.53	3320
M115QN24M	2013091	115	77.25	62.88	28.00	28.75	4.50	9.12	6.00	7/8, 1, 1-1/8, 1-1/4	1.75	2.53	3950
M115QN24H	2013095	115	77.25	62.88	32.00	28.75	4.50	9.12	6.00	7/8, 1, 1-1/8, 1-1/4	1.75	2.53	4430
M115SX18L	2013099	115	71.25	56.88	22.00	22.75	4.50	9.12	6.00	5/8, 3/4, 7/8, 1	1.75	2.53	2645
M115SX18M	2013103	115	71.25	56.88	26.12	22.75	4.50	9.12	6.00	5/8, 3/4, 7/8, 1	1.75	2.53	2885
M115SX18H	2013107	115	71.25	56.88	28.12	22.75	4.50	9.12	6.00	5/8, 3/4, 7/8, 1	1.75	2.53	3033
M115SX20L	2013111	115	73.25	58.88	22.00	24.75	4.50	9.12	6.00	3/4, 7/8, 1, 1-1/8	1.75	2.53	2849
M115SX20M	2013115	115	73.25	58.88	26.50	24.75	4.50	9.12	6.00	3/4, 7/8, 1, 1-1/8	1.75	2.53	3145
M115SX20H	2013119	115	73.25	58.88	30.50	24.75	4.50	9.12	6.00	3/4, 7/8, 1, 1-1/8	1.75	2.53	3497
M115SX24L	2013123	115	77.25	62.88	22.03	28.75	4.50	9.12	6.00	7/8, 1, 1-1/8, 1-1/4	1.75	2.53	3325
M115SX24M	2013127	115	77.25	62.88	29.78	28.75	4.50	9.12	6.00	7/8, 1, 1-1/8, 1-1/4	1.75	2.53	3957
M115SX24H	2013131	115	77.25	62.88	33.78	28.75	4.50	9.12	6.00	7/8, 1, 1-1/8, 1-1/4	1.75	2.53	4437
<b>125 Tons</b>													
M125Q24L	2013135	125	72	62.88	16.44	28.75	4.50	9.12	6.00	7/8, 1, 1-1/8, 1-1/4	-	-	2753

# McKissick® 380 Series Crane Blocks

## 380 Series Crane Blocks

Model No.	Inquiry Stock No.	Working Load Limit (Tons) †	A Overall Length (in)	B Net Length (in)	E Thickness (in)	F Width (in)	H Throat Opening with Flapper (in)	J Hook Thickness (in)	K Hook Width (in)	Standard Wireline Sizes (in)*	Dead End ‡		Weight Each (lb)
											T Thickness (in)	U Pin Hole (in)	
M125Q24M	2013139	125	72.00	62.88	24.19	28.75	4.50	9.12	6.00	7/8, 1, 1-1/8, 1-1/4	-	-	3385
M125Q24H	2013143	125	72.00	62.88	28.19	28.75	4.50	9.12	6.00	7/8, 1, 1-1/8, 1-1/4	-	-	3865
M125QN24L	2013147	125	77.25	62.88	20.25	28.75	4.50	9.12	6.00	7/8, 1, 1-1/8, 1-1/4	1.75	2.53	3320
M125QN24M	2013151	125	77.25	62.88	28.00	28.75	4.50	9.12	6.00	7/8, 1, 1-1/8, 1-1/4	1.75	2.53	3950
M125QN24H	2013155	125	77.25	62.88	32.00	28.75	4.50	9.12	6.00	7/8, 1, 1-1/8, 1-1/4	1.75	2.53	4430
M125SX18L	2013159	125	71.25	56.88	22.00	22.75	4.50	9.12	6.00	5/8, 3/4, 7/8, 1	1.75	2.53	2645
M125SX18M	2013163	125	71.25	56.88	26.12	22.75	4.50	9.12	6.00	5/8, 3/4, 7/8, 1	1.75	2.53	2885
M125SX18H	2013167	125	71.25	56.88	28.12	22.75	4.50	9.12	6.00	5/8, 3/4, 7/8, 1	1.75	2.53	3033
M125SX20L	2013171	125	73.25	58.88	22.00	24.75	4.50	9.12	6.00	3/4, 7/8, 1, 1-1/8	1.75	2.53	2849
M125SX20M	2013175	125	73.25	58.88	26.50	24.75	4.50	9.12	6.00	3/4, 7/8, 1, 1-1/8	1.75	2.53	3145
M125SX20H	2013179	125	73.25	58.88	30.50	24.75	4.50	9.12	6.00	3/4, 7/8, 1, 1-1/8	1.75	2.53	3497
M125SX24L	2013183	125	77.25	62.88	22.03	28.75	4.50	9.12	6.00	7/8, 1, 1-1/8, 1-1/4	1.75	2.53	3325
M125SX24M	2013187	125	77.25	62.88	29.78	28.75	4.50	9.12	6.00	7/8, 1, 1-1/8, 1-1/4	1.75	2.53	3957
M125SX24H	2013188	125	77.25	62.88	33.78	28.75	4.50	9.12	6.00	7/8, 1, 1-1/8, 1-1/4	1.75	2.53	4437
<b>130 Tons</b>													
M130Q24L	2013192	130	72.00	62.88	16.44	28.75	4.50	9.12	6.00	7/8, 1, 1-1/8, 1-1/4	-	-	2753
M130Q24M	2013196	130	72.00	62.88	24.19	28.75	4.50	9.12	6.00	7/8, 1, 1-1/8, 1-1/4	-	-	3385
M130Q24H	2013200	130	72.00	62.88	28.19	28.75	4.50	9.12	6.00	7/8, 1, 1-1/8, 1-1/4	-	-	3865
M130QN24L	2013191	130	77.25	62.88	20.25	28.75	4.50	9.12	6.00	7/8, 1, 1-1/8, 1-1/4	1.75	2.53	3320
M130QN24M	2013195	130	77.25	62.88	28.00	28.75	4.50	9.12	6.00	7/8, 1, 1-1/8, 1-1/4	1.75	2.53	3950
M130QN24H	2013199	130	77.25	62.88	32.00	28.75	4.50	9.12	6.00	7/8, 1, 1-1/8, 1-1/4	1.75	2.53	4430
M130SX18L	2013203	130	71.25	56.88	22.00	22.75	4.50	9.12	6.00	5/8, 3/4, 7/8, 1	1.75	2.53	2645
M130SX18M	2013207	130	71.25	56.88	26.12	22.75	4.50	9.12	6.00	5/8, 3/4, 7/8, 1	1.75	2.53	2885
M130SX18H	2013211	130	71.25	56.88	28.12	22.75	4.50	9.12	6.00	5/8, 3/4, 7/8, 1	1.75	2.53	3033
M130SX20L	2013218	130	73.25	58.88	22.00	24.75	4.50	9.12	6.00	3/4, 7/8, 1, 1-1/8	1.75	2.53	2849
M130SX20M	2013219	130	73.25	58.88	26.50	24.75	4.50	9.12	6.00	3/4, 7/8, 1, 1-1/8	1.75	2.53	3145
M130SX20H	2013223	130	73.25	58.88	30.50	24.75	4.50	9.12	6.00	3/4, 7/8, 1, 1-1/8	1.75	2.53	3497
M130SX24L	2013227	130	77.25	62.88	22.03	28.75	4.50	9.12	6.00	7/8, 1, 1-1/8, 1-1/4	1.75	2.53	3325
M130SX24M	2013231	130	77.25	62.88	29.78	28.75	4.50	9.12	6.00	7/8, 1, 1-1/8, 1-1/4	1.75	2.53	3957
M130SX24H	2013235	130	77.25	62.88	33.78	28.75	4.50	9.12	6.00	7/8, 1, 1-1/8, 1-1/4	1.75	2.53	4437
<b>140 Tons</b>													
M140Q24L	2013252	140	72.00	62.88	16.44	28.75	4.50	9.12	6.00	7/8, 1, 1-1/8, 1-1/4	—	—	2753
M140Q24M	2013256	140	72.00	62.88	24.19	28.75	4.50	9.12	6.00	7/8, 1, 1-1/8, 1-1/4	—	—	3385
M140Q24H	2013260	140	72.00	62.88	28.19	28.75	4.50	9.12	6.00	7/8, 1, 1-1/8, 1-1/4	—	—	3865
M140QN24L	2013251	140	77.25	62.88	20.25	28.75	4.50	9.12	6.00	7/8, 1, 1-1/8, 1-1/4	1.75	2.53	3320
M140QN24M	2013255	140	77.25	62.88	28.00	28.75	4.50	9.12	6.00	7/8, 1, 1-1/8, 1-1/4	1.75	2.53	3950
M140QN24H	2013259	140	77.25	62.88	32.00	28.75	4.50	9.12	6.00	7/8, 1, 1-1/8, 1-1/4	1.75	2.53	4430
M140SX18L	2013263	140	71.25	56.88	22.00	22.75	4.50	9.12	6.00	5/8, 3/4, 7/8, 1	1.75	2.53	2645
M140SX18M	2013267	140	71.25	56.88	26.12	22.75	4.50	9.12	6.00	5/8, 3/4, 7/8, 1	1.75	2.53	2885
M140SX18H	2013271	140	71.25	56.88	28.12	22.75	4.50	9.12	6.00	5/8, 3/4, 7/8, 1	1.75	2.53	3033
M140SX20L	2013275	140	73.25	58.88	22.00	24.75	4.50	9.12	6.00	3/4, 7/8, 1, 1-1/8	1.75	2.53	2849
M140SX20M	2013279	140	73.25	58.88	26.50	24.75	4.50	9.12	6.00	3/4, 7/8, 1, 1-1/8	1.75	2.53	3145
M140SX20H	2013283	140	73.25	58.88	30.50	24.75	4.50	9.12	6.00	3/4, 7/8, 1, 1-1/8	1.75	2.53	3497
M140SX24L	2013287	140	77.25	62.88	22.03	28.75	4.50	9.12	6.00	7/8, 1, 1-1/8, 1-1/4	1.75	2.53	3325
M140SX24M	2013291	140	77.25	62.88	29.78	28.75	4.50	9.12	6.00	7/8, 1, 1-1/8, 1-1/4	1.75	2.53	3957
M140SX24H	2013295	140	77.25	62.88	33.78	28.75	4.50	9.12	6.00	7/8, 1, 1-1/8, 1-1/4	1.75	2.53	4437
<b>150 Tons</b>													
M150Q24L	2013299	150	72.00	62.88	16.44	28.75	4.50	9.12	6.00	7/8, 1, 1-1/8, 1-1/4	—	—	2753
M150Q24M	2013303	150	72.00	62.88	24.19	28.75	4.50	9.12	6.00	7/8, 1, 1-1/8, 1-1/4	—	—	3385
M150Q24H	2013307	150	72.00	62.88	28.19	28.75	4.50	9.12	6.00	7/8, 1, 1-1/8, 1-1/4	—	—	3865
M150QN24L	2013311	150	77.25	62.88	22.00	28.75	4.50	9.12	6.00	7/8, 1, 1-1/8, 1-1/4	1.75	2.53	3655
M150QN24M	2013315	150	77.25	62.88	29.75	28.75	4.50	9.12	6.00	7/8, 1, 1-1/8, 1-1/4	1.75	2.53	4288
M150QN24H	2013319	150	77.25	62.88	33.75	28.75	4.50	9.12	6.00	7/8, 1, 1-1/8, 1-1/4	1.75	2.53	4770
M150SX20L	2013323	150	73.25	58.88	22.00	24.75	4.50	9.12	6.00	3/4, 7/8, 1, 1-1/8	1.75	2.53	2849
M150SX20M	2013327	150	73.25	58.88	26.50	24.75	4.50	9.12	6.00	3/4, 7/8, 1, 1-1/8	1.75	2.53	3145
M150SX20H	2013331	150	73.25	58.88	30.50	24.75	4.50	9.12	6.00	3/4, 7/8, 1, 1-1/8	1.75	2.53	3497
M150SX24L	2013335	150	77.25	62.88	22.03	28.75	4.50	9.12	6.00	7/8, 1, 1-1/8, 1-1/4	1.75	2.53	3325
M150SX24M	2013339	150	77.25	62.88	29.78	28.75	4.50	9.12	6.00	7/8, 1, 1-1/8, 1-1/4	1.75	2.53	3957
M150SX24H	2013343	150	77.25	62.88	33.78	28.75	4.50	9.12	6.00	7/8, 1, 1-1/8, 1-1/4	1.75	2.53	4437
<b>165 Tons</b>													
M165Q24L	2013347	165	72.00	62.88	16.44	28.75	4.50	9.12	6.00	7/8, 1, 1-1/8, 1-1/4	—	—	2753
M165Q24M	2013351	165	72.00	62.88	24.19	28.75	4.50	9.12	6.00	7/8, 1, 1-1/8, 1-1/4	—	—	3385
M165Q24H	2013355	165	72.00	62.88	28.19	28.75	4.50	9.12	6.00	7/8, 1, 1-1/8, 1-1/4	—	—	3865
M165QN24L	2013359	165	77.25	62.88	22.00	28.75	4.50	9.12	6.00	7/8, 1, 1-1/8, 1-1/4	1.75	2.53	3655
M165QN24M	2013363	165	77.25	62.88	29.75	28.75	4.50	9.12	6.00	7/8, 1, 1-1/8, 1-1/4	1.75	2.53	4288
M165QN24H	2013367	165	77.25	62.88	33.75	28.75	4.50	9.12	6.00	7/8, 1, 1-1/8, 1-1/4	1.75	2.53	4770
M165SX20L	2013371	165	73.25	58.88	22.00	24.75	4.50	9.12	6.00	3/4, 7/8, 1, 1-1/8	1.75	2.53	2849
M165SX20M	2013375	165	73.25	58.88	26.50	24.75	4.50	9.12	6.00	3/4, 7/8, 1, 1-1/8	1.75	2.53	3145
M165SX20H	2013379	165	73.25	58.88	30.50	34.75	4.50	9.12	6.00	3/4, 7/8, 1, 1-1/8	1.75	2.53	3497
M165SX24L	2013383	165	77.25	62.88	22.03	28.75	4.50	9.12	6.00	7/8, 1, 1-1/8, 1-1/4	1.75	2.53	3325

McKissick  
Blocks



## 380 Series Crane Blocks

Model No.	Inquiry Stock No.	Working Load Limit (Tons) †	A Overall Length (in)	B Net Length (in)	E Thickness (in)	F Width (in)	H Throat Opening with Flapper (in)	J Hook Thickness (in)	K Hook Width (in)	Standard Wireline Sizes (in)*	Dead End ‡		Weight Each (lb)
											T Thickness (in)	U Pin Hole (in)	
M165SX24M	2013387	165	77.25	62.88	29.78	28.75	4.50	9.12	6.00	7/8, 1, 1-1/8, 1-1/4	1.75	2.53	3957
M165SX24H	2013391	165	77.25	62.88	33.78	28.75	4.50	9.12	6.00	7/8, 1, 1-1/8, 1-1/4	1.75	2.53	4437
<b>200 Tons</b>													
M200QN24L	2013395	200	82.75	67.75	24.00	28.75	5.00	9.75	7.00	7/8, 1, 1-1/8, 1-1/4	1.75	2.53	4600
M200QN24M	2013399	200	82.75	67.75	31.75	28.75	5.00	9.75	7.00	7/8, 1, 1-1/8, 1-1/4	1.75	2.53	5377
M200QN24H	2013403	200	82.75	67.75	35.75	28.75	5.00	9.75	7.00	7/8, 1, 1-1/8, 1-1/4	1.75	2.53	5840
M200QN30L	2013396	200	88.75	73.75	24.00	34.75	5.00	9.75	7.00	1, 1-1/8, 1-1/4, 1-3/8	1.75	2.53	5243
M200QN30M	2013400	200	88.75	73.75	26.50	34.75	5.00	9.75	7.00	1, 1-1/8, 1-1/4, 1-3/8	1.75	2.53	6142
M200QN30H	2013404	200	88.75	73.75	28.00	34.75	5.00	9.75	7.00	1, 1-1/8, 1-1/4, 1-3/8	1.75	2.53	6722
M200SX24L	2013407	200	82.75	67.75	24.00	28.75	5.00	9.75	7.00	7/8, 1, 1-1/8, 1-1/4	1.75	2.53	4377
M200SX24M	2013411	200	82.75	67.75	31.75	28.75	5.00	9.75	7.00	7/8, 1, 1-1/8, 1-1/4	1.75	2.53	5015
M200SX24H	2013415	200	82.75	67.75	35.75	28.75	5.00	9.75	7.00	7/8, 1, 1-1/8, 1-1/4	1.75	2.53	5492
M200SX30L	2013419	200	88.75	73.75	24.00	34.75	5.00	9.75	7.00	1, 1-1/8, 1-1/4, 1-3/8	1.75	2.53	5600
M200SX30M	2013423	200	88.75	73.75	26.50	34.75	5.00	9.75	7.00	1, 1-1/8, 1-1/4, 1-3/8	1.75	2.53	7070
M200SX30H	2013427	200	88.75	73.75	28.00	34.75	5.00	9.75	7.00	1, 1-1/8, 1-1/4, 1-3/8	1.75	2.53	7214
<b>225 Tons</b>													
M225QN24L	2013420	225	82.75	67.75	24.00	28.75	6.25	10.62	7.25	7/8, 1, 1-1/8, 1-1/4	1.75	2.53	4672
M225QN24M	2013424	225	82.75	67.75	31.75	28.75	6.25	10.62	7.25	7/8, 1, 1-1/8, 1-1/4	1.75	2.53	5377
M225QN24H	2013428	225	82.75	67.75	35.75	28.75	6.25	10.62	7.25	7/8, 1, 1-1/8, 1-1/4	1.75	2.53	5840
M225QN30L	2013421	225	88.75	73.75	24.00	34.75	6.25	10.62	7.25	1, 1-1/8, 1-1/4, 1-3/8	1.75	2.53	5243
M225QN30M	2013425	225	88.75	73.75	26.50	34.75	6.25	10.62	7.25	1, 1-1/8, 1-1/4, 1-3/8	1.75	2.53	6142
M225QN30H	2013429	225	88.75	73.75	28.00	34.75	6.25	10.62	7.25	1, 1-1/8, 1-1/4, 1-3/8	1.75	2.53	6722
M225SX24L	2013422	225	82.75	67.75	24.00	28.75	6.25	10.62	7.25	7/8, 1, 1-1/8, 1-1/4	1.75	2.53	4377
M225SX24M	2013426	225	82.75	67.75	31.75	28.75	6.25	10.62	7.25	7/8, 1, 1-1/8, 1-1/4	1.75	2.53	5010
M225SX24H	2013430	225	82.75	67.75	35.75	28.75	6.25	10.62	7.25	7/8, 1, 1-1/8, 1-1/4	1.75	2.53	5492
M225SX30L	2013432	225	88.75	73.75	24.00	34.75	6.25	10.62	7.25	1, 1-1/8, 1-1/4, 1-3/8	1.75	2.53	5734
M225SX30M	2013436	225	88.75	73.75	26.50	34.75	6.25	10.62	7.25	1, 1-1/8, 1-1/4, 1-3/8	1.75	2.53	6634
M225SX30H	2013440	225	88.75	73.75	28.00	34.75	6.25	10.62	7.25	1, 1-1/8, 1-1/4, 1-3/8	1.75	2.53	7214
<b>250 Tons</b>													
M250SX30L	2013431	250	93.25	77.38	28.50	36.50	6.25	10.62	7.25	1, 1-1/8, 1-1/4, 1-3/8	2.25	2.53	7274
M250SX30M	2013435	250	93.25	77.38	32.50	36.50	6.25	10.62	7.25	1, 1-1/8, 1-1/4, 1-3/8	2.25	2.53	8154
M250SX30H	2013439	250	93.25	77.38	34.50	36.50	6.25	10.62	7.25	1, 1-1/8, 1-1/4, 1-3/8	2.25	2.53	8724
M250SV24L	2013443	250	87.25	71.38	36.00	28.75	6.25	10.62	7.25	7/8, 1, 1-1/8, 1-1/4	2.25	2.53	6459
M250SV24M	2013447	250	87.25	71.38	43.75	28.75	6.25	10.62	7.25	7/8, 1, 1-1/8, 1-1/4	2.25	2.53	7163
M250SV24H	2013451	250	87.25	71.38	47.75	28.75	6.25	10.62	7.25	7/8, 1, 1-1/8, 1-1/4	2.25	2.53	7628
<b>275 Tons</b>													
M275SX30L	2013456	275	93.25	77.38	28.50	36.50	6.25	10.62	7.25	1, 1-1/8, 1-1/4, 1-3/8	2.25	2.53	7274
M275SX30M	2013460	275	93.25	77.38	32.50	36.50	6.25	10.62	7.25	1, 1-1/8, 1-1/4, 1-3/8	2.25	2.53	8154
M275SX30H	2013464	275	93.25	77.38	34.50	36.50	6.25	10.62	7.25	1, 1-1/8, 1-1/4, 1-3/8	2.25	2.53	8724
M275SV24L	2013457	275	87.25	71.38	36.00	28.75	6.25	10.62	7.25	7/8, 1, 1-1/8, 1-1/4	2.25	2.53	6459
M275SV24M	2013461	275	87.25	71.38	43.75	28.75	6.25	10.62	7.25	7/8, 1, 1-1/8, 1-1/4	2.25	2.53	7163
M275SV24H	2013465	275	87.25	71.38	47.75	28.75	6.25	10.62	7.25	7/8, 1, 1-1/8, 1-1/4	2.25	2.53	7628
<b>300 Tons</b>													
M300SX30L	2013479	300	93.25	77.38	28.50	36.50	6.25	10.62	7.25	1, 1-1/8, 1-1/4, 1-3/8	2.25	2.53	7274
M300SX30M	2013483	300	93.25	77.38	32.50	36.50	6.25	10.62	7.25	1, 1-1/8, 1-1/4, 1-3/8	2.25	2.53	8154
M300SX30H	2013487	300	93.25	77.38	34.50	36.50	6.25	10.62	7.25	1, 1-1/8, 1-1/4, 1-3/8	2.25	2.53	8724
M300SV24L	2013491	300	87.25	71.38	36.00	28.75	6.25	10.62	7.25	7/8, 1, 1-1/8, 1-1/4	2.25	2.53	6459
M300SV24M	2013495	300	87.25	71.38	43.75	28.75	6.25	10.62	7.25	7/8, 1, 1-1/8, 1-1/4	2.25	2.53	7163
M300SV24H	2013499	300	87.25	71.38	47.75	28.75	6.25	10.62	7.25	7/8, 1, 1-1/8, 1-1/4	2.25	2.53	7628
M300OCT30L	2013527	300	93.25	77.38	36.00	36.50	6.25	10.62	7.25	1, 1-1/8, 1-1/4, 1-3/8	2.25	2.53	10145
M300OCT30M	2013531	300	93.25	77.38	38.00	36.50	6.25	10.62	7.25	1, 1-1/8, 1-1/4, 1-3/8	2.25	2.53	10887
M300OCT30H	2013535	300	93.25	77.38	39.00	36.50	6.25	10.62	7.25	1, 1-1/8, 1-1/4, 1-3/8	2.25	2.53	11592

\* Additional Wireline sizes available upon request.

† Ultimate Load is 4 times the Working Load Limit unless otherwise noted.

‡ Dead End dimensions for 2, 3, & 4 sheave blocks are shown on page 310.

## 380 SERIES EASY REEVE® HOOK BLOCKS

- Wide range of products available.
  - Capacity: 5 to 80 Tons - Larger Models Available.
  - Sheave Sizes: 10" to 20".
  - Wireline Sizes: 7/16" to 1-1/4".
- All single point shank hooks are genuine Crosby®, forged alloy steel, Quenched and Tempered, and have the patented **QUIC-CHECK®** markings (Duplex hooks are available on most sizes).
- Design factor of 4:1 (unless otherwise noted).
- All Easy Reeve® Blocks are furnished standard with Roller Bearings.
- Reeving Guides Standard – All Models.
- Blocks thru 25 Tons use 319N hooks with S-4320 latches.
- Heavy Duty Positive Locking (PL) Latch – Models: 30 Tons and larger.
- Sheave lubrication through center pin - separate lube channel to each bearing.
- Sheaves fully protected by side plates.
- Dual action hook (swings and rotates).
- Repair parts available through worldwide distribution network.
- All Easy Reeve® blocks 16" and larger are furnished with McKissick® Roll-Forged sheaves with flame hardened grooves.
- Manufactured by an ISO 9001 and API Q1 certified facility.
- "Look for the Orange Hook . . . the mark of genuine McKissick® quality".



### OPTIONS AVAILABLE

- Duplex Hooks
- Swivel Tee and Shackle Assemblies
- Sheave Shrouds
- Anti-Rotation Hook-Locking Device
- Plate Steel Cheek Weights
- Third party testing with Certification available upon request

Center "Dead End" to promote better block travel under various reeving configurations

**Sheave Guards** that open to allow block reeving without removing the rope end fitting



The patented McKissick Split-Nut® is the standard retention system for standard crane blocks up to 100 Tons.

For custom orders contact our Block Hotline at: (800)727-1555, or reference the special request form on page 454.



**Flat Bottom** side plate for self standing during reeving process.



**380 Series Easy Reeve® Hook Block**

**Forged Crosby® alloy steel hooks with patented QUIC-CHECK® markings and Heavy Duty positive locking hook latch.**

The patented McKissick Split-Nut® is the standard retention system for standard crane blocks up to 100 Tons.

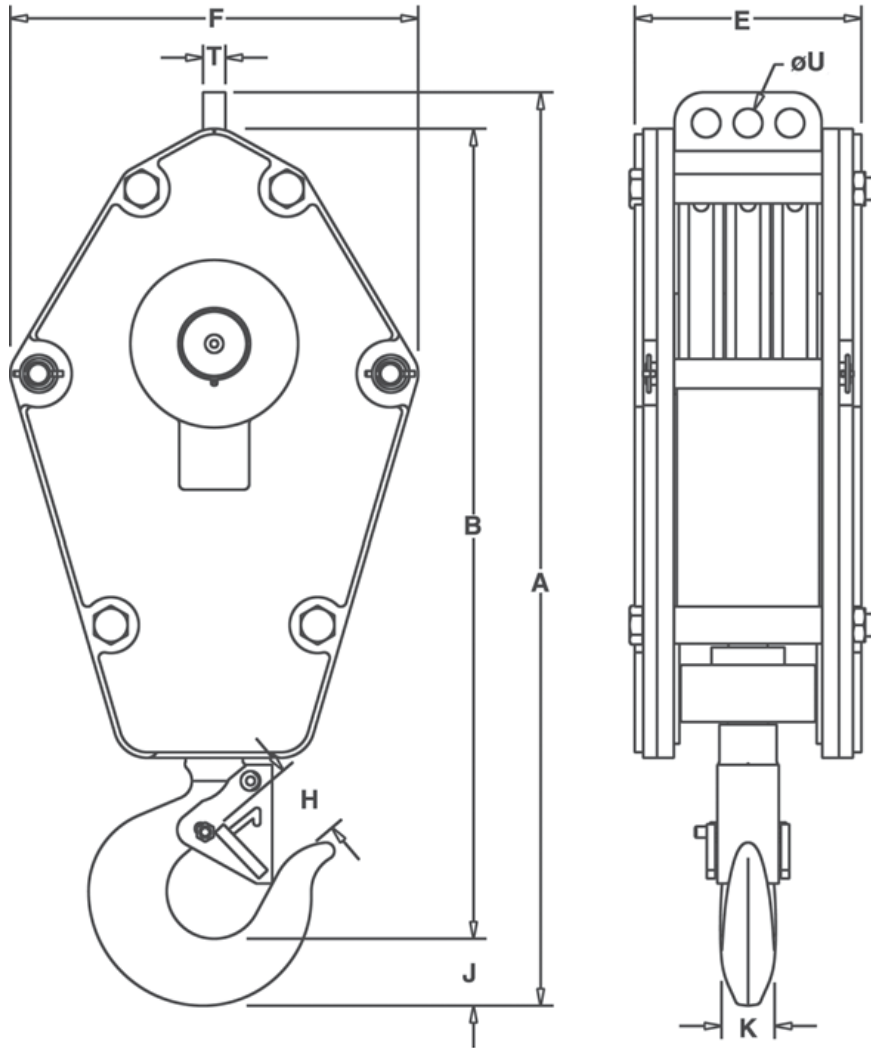

**Dead End Chart  
Double, Triple & Quad Sheave Blocks**

Wireline Size (in)	Dimensions (in)		Recommended Wedge Socket	
	T Thickness	U Hole Diameter	McKissick® US-422 / US-422T Utility Socket	
			Stock No.	Size
7/16	1.00	1.28	1044309+	US4 7/16
1/2	1.00	1.28	1044318+	US4 1/2
9/16	1.00	1.28	1044336+	US5 9/16
5/8	1.00	1.28	1044345+	US5 5/8
3/4	1.25	1.66	1044363+	US6 3/4
7/8	1.25	1.66	1038580	US7 7/8
1	1.25	1.66	1044417+	US8 1
1-1/8	1.75	2.56	1044426+	US10 1-1/8
1-1/4	1.75	2.56	1044435+	US10 1-1/4

+ US-422T TERMINATOR™ Style.

# McKissick® Easy Reeve® Crane Blocks



## McKissick® Easy Reeve® Crane Blocks

- Specify Wireline size when ordering.
- Dead End Dimensions on page 326 of this catalog.
- All sizes are RFID EQUIPPED.

Model No.	Inquiry Stock No.	Working Load Limit (Tons)*	A Overall Length (in)	B Net Length (in)	E Block Thickness (in)	F Block Width (in)	H Throat Opening with Latch (in)	J Hook Thickness (in)	K Hook Width (in)	Standard Wireline Size (in)	Weight Each (lb) †
<b>5 Tons</b>											
E5S10L	2014001	5	35.78	31.06	6.84	14.50	1.91	2.59	1.94	7/16 1/2 9/16 5/8	236
E5S10M	2014003	5	35.78	31.06	8.84	14.50	1.91	2.59	1.94	7/16 1/2 9/16 5/8	342
E5S10H	2014004	5	35.78	31.06	10.34	14.50	1.91	2.59	1.94	7/16 1/2 9/16 5/8	424
<b>10 Tons</b>											
E10S10L	2014011	10	35.78	31.06	6.84	14.50	1.91	2.59	1.94	7/16 1/2 9/16 5/8	236
E10S10M	2014013	10	35.78	31.06	8.84	14.50	1.91	2.59	1.94	7/16 1/2 9/16 5/8	342
E10S10H	2014014	10	35.78	31.06	10.34	14.50	1.91	2.59	1.94	7/16 1/2 9/16 5/8	424
E10S14L	2014021	10	39.40	34.69	6.84	18.25	1.91	2.59	1.94	1/2 9/16 5/8 3/4	276
E10S14M	2014023	10	39.40	34.69	8.84	18.25	1.91	2.59	1.94	1/2 9/16 5/8 3/4	427
E10S14H	2014024	10	39.40	34.69	10.34	18.25	1.91	2.59	1.94	1/2 9/16 5/8 3/4	542
E10S16L	2014031	10	43.15	38.44	6.84	20.50	1.91	2.59	1.94	9/16 5/8 3/4 7/8	329
E10S16M	2014033	10	43.15	38.44	8.84	20.50	1.91	2.59	1.94	9/16 5/8 3/4 7/8	527
E10S16H	2014034	10	43.15	38.44	10.34	20.50	1.91	2.59	1.94	9/16 5/8 3/4 7/8	678
E10D10L	2014041	10	35.78	31.06	6.84	14.50	1.91	2.59	1.94	7/16 1/2 9/16 5/8	268
E10D10M	2014043	10	35.78	31.06	8.84	14.50	1.91	2.59	1.94	7/16 1/2 9/16 5/8	374
E10D10H	2014044	10	35.78	31.06	10.34	14.50	1.91	2.59	1.94	7/16 1/2 9/16 5/8	450
E10D12L	2014051	10	37.28	32.56	6.84	16.50	1.91	2.59	1.94	1/2 9/16 5/8 3/4	278
E10D12M	2014053	10	37.28	32.56	8.84	16.50	1.91	2.59	1.94	1/2 9/16 5/8 3/4	402
E10D12H	2014054	10	37.28	32.56	10.34	16.50	1.91	2.59	1.94	1/2 9/16 5/8 3/4	497
E10T10L	2014061	10	35.78	31.06	8.14	14.50	1.91	2.59	1.94	7/16 1/2 9/16 5/8	318
E10T10M	2014063	10	35.78	31.06	10.14	14.50	1.91	2.59	1.94	7/16 1/2 9/16 5/8	424
E10T10H	2014064	10	35.78	31.06	11.64	14.50	1.91	2.59	1.94	7/16 1/2 9/16 5/8	506
E10T12L	2014071	10	37.28	32.56	8.14	16.50	1.91	2.59	1.94	1/2 9/16 5/8 3/4	323
E10T12M	2014073	10	37.28	32.56	10.14	16.50	1.91	2.59	1.94	1/2 9/16 5/8 3/4	446
E10T12H	2014074	10	37.28	32.56	11.64	16.50	1.91	2.59	1.94	1/2 9/16 5/8 3/4	541
E10Q14L	2014081	10	39.40	34.69	10.38	18.25	1.91	2.59	1.94	1/2 9/16 5/8 3/4	427
E10Q14M	2014083	10	39.40	34.69	12.38	18.25	1.91	2.59	1.94	1/2 9/16 5/8 3/4	588
E10Q14H	2014084	10	39.40	34.69	13.88	18.25	1.91	2.59	1.94	1/2 9/16 5/8 3/4	703
<b>15 Tons</b>											
E15S10L	2014091	15	35.78	31.06	6.84	14.50	1.91	2.59	1.94	7/16 1/2 9/16 5/8	236
E15S10M	2014093	15	35.78	31.06	8.84	14.50	1.91	2.59	1.94	7/16 1/2 9/16 5/8	342
E15S10H	2014094	15	35.78	31.06	10.34	14.50	1.91	2.59	1.94	7/16 1/2 9/16 5/8	424
E15S12L	2014101	15	37.28	32.56	6.84	16.50	1.91	2.59	1.94	1/2 9/16 5/8 3/4	251
E15S12M	2014103	15	37.28	32.56	8.84	16.50	1.91	2.59	1.94	1/2 9/16 5/8 3/4	375
E15S12H	2014104	15	37.28	32.56	10.34	16.50	1.91	2.59	1.94	1/2 9/16 5/8 3/4	470
E15S14L	2014111	15	39.40	34.69	6.84	18.25	1.91	2.59	1.94	1/2 9/16 5/8 3/4	276
E15S14M	2014113	15	39.40	34.69	8.84	18.25	1.91	2.59	1.94	1/2 9/16 5/8 3/4	427
E15S14H	2014114	15	39.40	34.69	10.34	18.25	1.91	2.59	1.94	1/2 9/16 5/8 3/4	542
E15S16L	2014121	15	43.15	38.44	6.84	20.50	1.91	2.59	1.94	9/16 5/8 3/4 7/8	329
E15S16M	2014123	15	43.15	38.44	8.84	20.50	1.91	2.59	1.94	9/16 5/8 3/4 7/8	527
E15S16H	2014124	15	43.15	38.44	10.34	20.50	1.91	2.59	1.94	9/16 5/8 3/4 7/8	678
E15D10L	2014131	15	35.78	31.06	6.84	14.50	1.91	2.59	1.94	7/16 1/2 9/16 5/8	268
E15D10M	2014133	15	35.78	31.06	8.84	14.50	1.91	2.59	1.94	7/16 1/2 9/16 5/8	374
E15D10H	2014134	15	35.78	31.06	10.34	14.50	1.91	2.59	1.94	7/16 1/2 9/16 5/8	456
E15D12L	2014141	15	37.28	32.56	6.84	16.50	1.91	2.59	1.94	1/2 9/16 5/8 3/4	278
E15D12M	2014143	15	37.28	32.56	8.84	16.50	1.91	2.59	1.94	1/2 9/16 5/8 3/4	402
E15D12H	2014144	15	37.28	32.56	10.34	16.50	1.91	2.59	1.94	1/2 9/16 5/8 3/4	497
E15T10L	2014151	15	35.78	31.06	8.14	14.50	1.91	2.59	1.94	7/16 1/2 9/16 5/8	318
E15T10M	2014153	15	35.78	31.06	10.14	14.50	1.91	2.59	1.94	7/16 1/2 9/16 5/8	424
E15T10H	2014154	15	35.78	31.06	11.64	14.50	1.91	2.59	1.94	7/16 1/2 9/16 5/8	506
E15T12L	2014161	15	37.28	32.56	8.14	16.50	1.91	2.59	1.94	1/2 9/16 5/8 3/4	323
E15T12M	2014163	15	37.28	32.56	10.14	16.50	1.91	2.59	1.94	1/2 9/16 5/8 3/4	446
E15T12H	2014164	15	37.28	32.56	11.64	16.50	1.91	2.59	1.94	1/2 9/16 5/8 3/4	541
E15Q14L	2014171	15	39.40	34.69	10.38	18.25	1.91	2.59	1.94	1/2 9/16 5/8 3/4	427
E15Q14M	2014173	15	39.40	34.69	12.38	18.25	1.91	2.59	1.94	1/2 9/16 5/8 3/4	588
E15Q14H	2014174	15	39.40	34.69	13.88	18.25	1.91	2.59	1.94	1/2 9/16 5/8 3/4	703
<b>20 Tons</b>											
E20S10L	2014181	20	37.69	32.59	6.84	14.50	2.75	2.97	2.38	7/16 1/2 9/16 5/8	249
E20S10M	2014182	20	37.69	32.59	8.84	14.50	2.75	2.97	2.38	7/16 1/2 9/16 5/8	355
E20S10H	2014184	20	37.69	32.59	10.34	14.50	2.75	2.97	2.38	7/16 1/2 9/16 5/8	436
E20S14L	2014191	20	41.31	36.22	6.84	18.25	2.75	2.97	2.38	1/2 9/16 5/8 3/4	293

McKissick Blocks



## McKissick® Easy Reeve® Crane Blocks

Model No.	Inquiry Stock No.	Working Load Limit (Tons)*	A Overall Length (in)	B Net Length (in)	E Block Thickness (in)	F Block Width (in)	H Throat Opening with Latch (in)	J Hook Thickness (in)	K Hook Width (in)	Standard Wireline Size (in)	Weight Each (lb) †
E20S14M	2014193	20	41.31	36.22	8.84	18.25	2.75	2.97	2.38	1/2 9/16 5/8 3/4	443
E20S14H	2014194	20	41.31	36.22	10.34	18.25	2.75	2.97	2.38	1/2 9/16 5/8 3/4	559
E20S18L	2014201	20	47.06	41.97	6.84	22.25	2.75	2.97	2.38	1/2 9/16 5/8 3/4	391
E20S18M	2014203	20	47.06	41.97	9.09	22.25	2.75	2.97	2.38	1/2 9/16 5/8 3/4	654
E20S18H	2014204	20	47.06	41.97	10.59	22.25	2.75	2.97	2.38	1/2 9/16 5/8 3/4	833
E20D12L	2014211	20	39.19	34.09	6.84	16.50	2.75	2.97	2.38	1/2 9/16 5/8 3/4	291
E20D12M	2014213	20	39.19	34.09	8.84	16.50	2.75	2.97	2.38	1/2 9/16 5/8 3/4	414
E20D12H	2014214	20	39.19	34.09	10.34	16.50	2.75	2.97	2.38	1/2 9/16 5/8 3/4	509
E20D14L	2014221	20	41.31	36.22	6.84	18.25	2.75	2.97	2.38	1/2 9/16 5/8 3/4	326
E20D14M	2014223	20	41.31	36.22	8.84	18.25	2.75	2.97	2.38	1/2 9/16 5/8 3/4	477
E20D14H	2014224	20	41.31	36.22	10.34	18.25	2.75	2.97	2.38	1/2 9/16 5/8 3/4	592
E20T12L	2014231	20	39.19	34.09	8.14	16.50	2.75	2.97	2.38	1/2 9/16 5/8 3/4	334
E20T12M	2014233	20	39.19	34.09	10.14	16.50	2.75	2.97	2.38	1/2 9/16 5/8 3/4	458
E20T12H	2014234	20	39.19	34.09	11.64	16.50	2.75	2.97	2.38	1/2 9/16 5/8 3/4	553
E20T14L	2014241	20	41.31	36.22	8.14	18.25	2.75	2.97	2.38	1/2 9/16 5/8 3/4	377
E20T14M	2014243	20	41.31	36.22	10.14	18.25	2.75	2.97	2.38	1/2 9/16 5/8 3/4	527
E20T14H	2014244	20	41.31	36.22	11.64	18.25	2.75	2.97	2.38	1/2 9/16 5/8 3/4	643
E20Q12L	2014251	20	39.19	34.09	10.38	16.50	2.75	2.97	2.38	1/2 9/16 5/8 3/4	401
E20Q12M	2014253	20	39.19	34.09	12.38	16.50	2.75	2.97	2.38	1/2 9/16 5/8 3/4	525
E20Q12H	2014254	20	39.19	34.09	13.88	16.50	2.75	2.97	2.38	1/2 9/16 5/8 3/4	618
E20Q14L	2014261	20	41.31	36.22	10.38	18.25	2.75	2.97	2.38	1/2 9/16 5/8 3/4	450
E20Q14M	2014263	20	41.31	36.22	12.38	18.25	2.75	2.97	2.38	1/2 9/16 5/8 3/4	601
E20Q14H	2014264	20	41.31	36.22	13.88	18.25	2.75	2.97	2.38	1/2 9/16 5/8 3/4	715
<b>25 Tons</b>											
E25S16L	2014271	25	45.06	39.97	6.84	20.50	2.75	2.97	2.38	9/16 5/8 3/4 7/8	342
E25S16M	2014273	25	45.06	39.97	8.84	20.50	2.75	2.97	2.38	9/16 5/8 3/4 7/8	539
E25S16H	2014274	25	45.06	39.97	10.34	20.50	2.75	2.97	2.38	9/16 5/8 3/4 7/8	691
E25S18L	2014281	25	47.06	41.97	6.84	22.25	2.75	2.97	2.38	5/8 3/4 7/8 1	391
E25S18M	2014283	25	47.06	41.97	9.09	22.25	2.75	2.97	2.38	5/8 3/4 7/8 1	653
E25S18H	2014284	25	47.06	41.97	10.59	22.25	2.75	2.97	2.38	5/8 3/4 7/8 1	833
E25D12L	2014291	25	39.19	34.09	6.84	16.50	2.75	2.97	2.38	1/2 9/16 5/8 3/4	291
E25D12M	2014293	25	39.19	34.09	8.84	16.50	2.75	2.97	2.38	1/2 9/16 5/8 3/4	414
E25D12H	2014294	25	39.19	34.09	10.34	16.50	2.75	2.97	2.38	1/2 9/16 5/8 3/4	509
E25D14L	2014301	25	41.31	36.22	6.84	18.25	2.75	2.97	2.38	1/2 9/16 5/8 3/4	326
E25D14M	2014303	25	41.31	36.22	8.84	18.25	2.75	2.97	2.38	1/2 9/16 5/8 3/4	477
E25D14H	2014304	25	41.31	36.22	10.34	18.25	2.75	2.97	2.38	1/2 9/16 5/8 3/4	592
E25T12L	2014311	25	39.19	34.09	8.14	16.50	2.75	2.97	2.38	1/2 9/16 5/8 3/4	334
E25T12M	2014313	25	39.19	34.09	10.14	16.50	2.75	2.97	2.38	1/2 9/16 5/8 3/4	458
E25T12H	2014314	25	39.19	34.09	11.64	16.50	2.75	2.97	2.38	1/2 9/16 5/8 3/4	553
E25T14L	2014321	25	41.31	36.22	8.14	18.25	2.75	2.97	2.38	1/2 9/16 5/8 3/4	369
E25T14M	2014323	25	41.31	36.22	10.14	18.25	2.75	2.97	2.38	1/2 9/16 5/8 3/4	527
E25T14H	2014324	25	41.31	36.22	11.64	18.25	2.75	2.97	2.38	1/2 9/16 5/8 3/4	643
E25Q12L	2014331	25	39.19	34.09	10.38	16.50	2.75	2.97	2.38	1/2 9/16 5/8 3/4	401
E25Q12M	2014333	25	39.19	34.09	12.38	16.50	2.75	2.97	2.38	1/2 9/16 5/8 3/4	525
E25Q12H	2014334	25	39.19	34.09	13.88	16.50	2.75	2.97	2.38	1/2 9/16 5/8 3/4	618
E25Q14L	2014341	25	41.31	36.22	10.38	18.25	2.75	2.97	2.38	1/2 9/16 5/8 3/4	450
E25Q14M	2014343	25	41.31	36.22	12.38	18.25	2.75	2.97	2.38	1/2 9/16 5/8 3/4	601
E25Q14H	2014344	25	41.31	36.22	13.88	18.25	2.75	2.97	2.38	1/2 9/16 5/8 3/4	715
<b>30 Tons</b>											
E30S18L	2014351	30	51.56	46.19	6.84	22.25	3.25	3.62	3.00	5/8 3/4 7/8 1	456
E30S18M	2014353	30	51.56	46.19	9.09	22.25	3.25	3.62	3.00	5/8 3/4 7/8 1	718
E30S18H	2014354	30	51.56	46.19	10.59	22.25	3.25	3.62	3.00	5/8 3/4 7/8 1	898
E30S20L	2014356	30	55.06	46.19	6.84	24.50	3.25	3.62	3.00	3/4 7/8 1, 1-1/8	557
E30S20M	2014358	30	55.06	46.19	8.84	24.50	3.25	3.62	3.00	3/4 7/8 1, 1-1/8	867
E30S20H	2014359	30	55.06	46.19	10.34	24.50	3.25	3.62	3.00	3/4 7/8 1, 1-1/8	1103
E30D14L	2014361	30	43.81	38.44	6.84	18.25	3.25	3.62	3.00	1/2 9/16 5/8 3/4	377
E30D14M	2014363	30	43.81	38.44	8.84	18.25	3.25	3.62	3.00	1/2 9/16 5/8 3/4	528
E30D14H	2014364	30	43.81	38.44	10.34	18.25	3.25	3.62	3.00	1/2 9/16 5/8 3/4	643
E30D18L	2014371	30	51.56	46.19	6.84	22.25	3.25	3.62	3.00	5/8 3/4 7/8 1	516
E30D18M	2014373	30	51.56	46.19	9.09	22.25	3.25	3.62	3.00	5/8 3/4 7/8 1	779
E30D18H	2014374	30	51.56	46.19	10.59	22.25	3.25	3.62	3.00	5/8 3/4 7/8 1	959
E30T14L	2014381	30	45.81	40.44	8.14	18.25	3.25	3.62	3.00	1/2 9/16 5/8 3/4	437
E30T14M	2014383	30	45.81	40.44	10.14	18.25	3.25	3.62	3.00	1/2 9/16 5/8 3/4	587
E30T14H	2014384	30	45.81	40.44	11.64	18.25	3.25	3.62	3.00	1/2 9/16 5/8 3/4	703
E30T16L	2014391	30	49.56	44.19	8.14	20.50	3.25	3.62	3.00	9/16 5/8 3/4 7/8	505
E30T16M	2014393	30	49.56	44.19	10.14	20.50	3.25	3.62	3.00	9/16 5/8 3/4 7/8	703
E30T16H	2014394	30	49.56	44.19	11.64	20.50	3.25	3.62	3.00	9/16 5/8 3/4 7/8	854
E30Q14L	2014401	30	45.81	40.44	10.38	18.25	3.25	3.62	3.00	1/2 9/16 5/8 3/4	503
E30Q14M	2014403	30	45.81	40.44	12.38	18.25	3.25	3.62	3.00	1/2 9/16 5/8 3/4	654
E30Q14H	2014404	30	45.81	40.44	13.88	18.25	3.25	3.62	3.00	1/2 9/16 5/8 3/4	769

# McKissick® Easy Reeve® Crane Blocks

## McKissick® Easy Reeve® Crane Blocks

Model No.	Inquiry Stock No.	Working Load Limit (Tons)*	A Overall Length (in)	B Net Length (in)	E Block Thickness (in)	F Block Width (in)	H Throat Opening with Latch (in)	J Hook Thickness (in)	K Hook Width (in)	Standard Wireline Size (in)	Weight Each (lb) †
<b>35 Tons</b>											
E35S20L	2014406	35	59.12	52.81	6.84	24.50	3.00	4.56	3.63	3/4 7/8 1, 1-1/8	557
E35S20M	2014408	35	59.12	52.81	8.84	24.50	3.00	4.56	3.63	3/4 7/8 1, 1-1/8	867
E35S20H	2014409	35	59.12	52.81	10.34	24.50	3.00	4.56	3.63	3/4 7/8 1, 1-1/8	1103
E35D18L	2014411	35	55.62	49.31	6.84	22.25	3.00	4.56	3.63	5/8 3/4 7/8 1	568
E35D18M	2014413	35	55.62	49.31	9.09	22.25	3.00	4.56	3.63	5/8 3/4 7/8 1	831
E35D18H	2014414	35	55.62	49.31	10.59	22.25	3.00	4.56	3.63	5/8 3/4 7/8 1	1010
E35T14L	2014421	35	49.87	43.56	8.14	18.25	3.00	4.56	3.63	1/2 9/16 5/8 3/4	488
E35T14M	2014423	35	49.87	43.56	10.14	18.25	3.00	4.56	3.63	1/2 9/16 5/8 3/4	639
E35T14H	2014424	35	49.87	43.56	11.64	18.25	3.00	4.56	3.63	1/2 9/16 5/8 3/4	754
E35T16L	2014431	35	53.62	47.31	8.14	20.50	3.00	4.56	3.63	9/16 5/8 3/4 7/8	557
E35T16M	2014433	35	53.62	47.31	10.14	20.50	3.00	4.56	3.63	9/16 5/8 3/4 7/8	755
E35T16H	2014434	35	53.62	47.31	11.64	20.50	3.00	4.56	3.63	9/16 5/8 3/4 7/8	906
E35Q14L	2014441	35	49.87	43.56	10.38	18.25	3.00	4.56	3.63	1/2 9/16 5/8 3/4	555
E35Q14M	2014443	35	49.87	43.56	12.38	18.25	3.00	4.56	3.63	1/2 9/16 5/8 3/4	706
E35Q14H	2014444	35	49.87	43.56	13.88	18.25	3.00	4.56	3.63	1/2 9/16 5/8 3/4	820
<b>40 Tons</b>											
E40T14L	2014451	40	51.94	45.13	8.14	18.25	3.38	5.06	3.72	1/2 9/16 5/8 3/4	545
E40T14M	2014453	40	51.94	45.13	10.14	18.25	3.38	5.06	3.72	1/2 9/16 5/8 3/4	695
E40T14H	2014454	40	51.94	45.13	11.64	18.25	3.38	5.06	3.72	1/2 9/16 5/8 3/4	811
E40T16L	2014461	40	55.69	48.88	8.14	20.50	3.38	5.06	3.72	9/16 5/8 3/4 7/8	614
E40T16M	2014463	40	55.69	48.88	10.14	20.50	3.38	5.06	3.72	9/16 5/8 3/4 7/8	821
E40T16H	2014464	40	55.69	48.88	11.64	20.50	3.38	5.06	3.72	9/16 5/8 3/4 7/8	963
E40T18L	2014471	40	57.69	50.88	8.14	22.25	3.38	5.06	3.72	5/8 3/4 7/8 1	709
E40T18M	2014473	40	57.69	50.88	10.39	22.25	3.38	5.06	3.72	5/8 3/4 7/8 1	972
E40T18H	2014474	40	57.69	50.88	11.89	22.25	3.38	5.06	3.72	5/8 3/4 7/8 1	1096
E40Q14L	2014481	40	51.94	45.13	10.38	18.25	3.38	5.06	3.72	1/2 9/16 5/8 3/4	611
E40Q14M	2014483	40	51.94	45.13	12.38	18.25	3.38	5.06	3.72	1/2 9/16 5/8 3/4	762
E40Q14H	2014484	40	51.94	45.13	13.88	18.25	3.38	5.06	3.72	1/2 9/16 5/8 3/4	877
E40Q16L	2014491	40	55.69	48.88	10.38	20.50	3.38	5.06	3.72	9/16 5/8 3/4 7/8	691
E40Q16M	2014493	40	55.69	48.88	12.38	20.50	3.38	5.06	3.72	9/16 5/8 3/4 7/8	889
E40Q16H	2014494	40	55.69	48.88	13.88	20.50	3.38	5.06	3.72	9/16 5/8 3/4 7/8	1040
<b>45 Tons</b>											
E45T14L	2014501	45	51.94	45.13	8.14	18.25	3.38	5.06	3.72	1/2 9/16 5/8 3/4	545
E45T14M	2014503	45	51.94	45.13	10.14	18.25	3.38	5.06	3.72	1/2 9/16 5/8 3/4	695
E45T14H	2014504	45	51.94	45.13	11.64	18.25	3.38	5.06	3.72	1/2 9/16 5/8 3/4	811
E45T16L	2014511	45	55.69	48.88	8.14	20.50	3.38	5.06	3.72	9/16 5/8 3/4 7/8	614
E45T16M	2014513	45	55.69	48.88	10.14	20.50	3.38	5.06	3.72	9/16 5/8 3/4 7/8	821
E45T16H	2014514	45	55.69	48.88	11.64	20.50	3.38	5.06	3.72	9/16 5/8 3/4 7/8	963
E45T18L	2014521	45	57.69	50.88	8.14	22.25	3.38	5.06	3.72	5/8 3/4 7/8 1	709
E45T18M	2014523	45	57.69	50.88	10.39	22.25	3.38	5.06	3.72	5/8 3/4 7/8 1	972
E45T18H	2014524	45	57.69	50.88	11.89	22.25	3.38	5.06	3.72	5/8 3/4 7/8 1	1151
E45Q14L	2014531	45	51.94	45.13	10.38	18.25	3.38	5.06	3.72	1/2 9/16 5/8 3/4	611
E45Q14M	2014533	45	51.94	45.13	12.38	18.25	3.38	5.06	3.72	1/2 9/16 5/8 3/4	762
E45Q14H	2014534	45	51.94	45.13	13.88	18.25	3.38	5.06	3.72	1/2 9/16 5/8 3/4	877
E45Q16L	2014541	45	55.69	48.88	10.38	20.50	3.38	5.06	3.72	9/16 5/8 3/4 7/8	691
E45Q16M	2014543	45	55.69	48.88	12.38	20.50	3.38	5.06	3.72	9/16 5/8 3/4 7/8	889
E45Q16H	2014544	45	55.69	48.88	13.88	20.50	3.38	5.06	3.72	9/16 5/8 3/4 7/8	1040
<b>50 Tons</b>											
E50T18L	2014551	50	63.75	55.25	11.14	22.25	4.13	6.00	4.44	5/8 3/4 7/8 1	1046
E50T18M	2014553	50	63.75	55.25	13.38	22.25	4.13	6.00	4.44	5/8 3/4 7/8 1	1308
E50T18H	2014554	50	63.75	55.25	14.88	22.25	4.13	6.00	4.44	5/8 3/4 7/8 1	1487
E50Q16L	2014561	50	61.75	53.25	13.31	20.50	4.13	6.00	4.44	9/16 5/8 3/4 7/8	1067
E50Q16M	2014563	50	61.75	53.25	15.31	20.50	4.13	6.00	4.44	9/16 5/8 3/4 7/8	1215
E50Q16H	2014564	50	61.75	53.25	16.81	20.50	4.13	6.00	4.44	9/16 5/8 3/4 7/8	1416
E50QN16L	2014571	50	61.75	53.25	14.06	20.50	4.13	6.00	4.44	9/16 5/8 3/4 7/8	1146
E50QN16M	2014573	50	61.75	53.25	16.06	20.50	4.13	6.00	4.44	9/16 5/8 3/4 7/8	1344
E50QN16H	2014574	50	61.75	53.25	17.56	20.50	4.13	6.00	4.44	9/16 5/8 3/4 7/8	1495
<b>55 Tons</b>											
E55T18L	2014581	55	63.75	55.25	11.14	22.25	4.13	6.00	4.44	5/8 3/4 7/8 1	1046
E55T18M	2014583	55	63.75	55.25	13.38	22.25	4.13	6.00	4.44	5/8 3/4 7/8 1	1308
E55T18H	2014584	55	63.75	55.25	14.88	22.25	4.13	6.00	4.44	5/8 3/4 7/8 1	1487
E55Q16L	2014591	55	61.75	53.25	13.31	20.50	4.13	6.00	4.44	9/16 5/8 3/4 7/8	1067
E55Q16M	2014593	55	61.75	53.25	15.31	20.50	4.13	6.00	4.44	9/16 5/8 3/4 7/8	1265
E55Q16H	2014594	55	61.75	53.25	16.81	20.50	4.13	6.00	4.44	9/16 5/8 3/4 7/8	1416
E55QN16L	2014601	55	61.75	53.25	14.06	20.50	4.13	6.00	4.44	9/16 5/8 3/4 7/8	1146
E55QN16M	2014603	55	61.75	53.25	16.06	20.50	4.13	6.00	4.44	9/16 5/8 3/4 7/8	1344
E55QN16H	2014604	55	61.75	53.25	17.56	20.50	4.13	6.00	4.44	9/16 5/8 3/4 7/8	1495

McKissick  
Blocks

## McKissick® Easy Reeve® Crane Blocks

Model No.	Inquiry Stock No.	Working Load Limit (Tons)*	A Overall Length (in)	B Net Length (in)	E Block Thickness (in)	F Block Width (in)	H Throat Opening with Latch (in)	J Hook Thickness (in)	K Hook Width (in)	Standard Wireline Size (in)	Weight Each (lb) †
<b>60 Tons</b>											
E60T20L	2014611	60	67.25	58.75	11.14	24.50	4.13	6.00	4.44	3/4 7/8 1, 1-1/8	1170
E60T20M	2014613	60	67.25	58.75	13.14	24.50	4.13	6.00	4.44	3/4 7/8 1, 1-1/8	1472
E60T20H	2014614	60	67.25	58.75	14.64	24.50	4.13	6.00	4.44	3/4 7/8 1, 1-1/8	1672
E60Q18L	2014621	60	63.75	55.25	13.31	22.25	4.13	6.00	4.44	5/8 3/4 7/8 1	1148
E60Q18M	2014623	60	63.75	55.25	15.56	22.25	4.13	6.00	4.44	5/8 3/4 7/8 1	1411
E60Q18H	2014624	60	63.75	55.25	17.06	22.25	4.13	6.00	4.44	5/8 3/4 7/8 1	1590
E60QN18L	2014631	60	63.75	55.25	14.06	22.25	4.13	6.00	4.44	5/8 3/4 7/8 1	1213
E60QN18M	2014633	60	63.75	55.25	16.31	22.25	4.13	6.00	4.44	5/8 3/4 7/8 1	1476
E60QN18H	2014634	60	63.75	55.25	17.81	22.25	4.13	6.00	4.44	5/8 3/4 7/8 1	1654
E60QN20L	2014641	60	67.25	58.75	14.06	24.50	4.13	6.00	4.44	3/4 7/8 1, 1-1/8	1384
E60QN20M	2014643	60	67.25	58.75	16.06	24.50	4.13	6.00	4.44	3/4 7/8 1, 1-1/8	1686
E60QN20H	2014644	60	67.25	58.75	17.56	24.50	4.13	6.00	4.44	3/4 7/8 1, 1-1/8	1886
<b>65 Tons</b>											
E65T20L	2014651	65	67.25	58.75	11.14	24.50	4.13	6.00	4.44	3/4 7/8 1, 1-1/8	1170
E65T20M	2014653	65	67.25	58.75	13.14	24.50	4.13	6.00	4.44	3/4 7/8 1, 1-1/8	1472
E65T20H	2014654	65	67.25	58.75	14.64	24.50	4.13	6.00	4.44	3/4 7/8 1, 1-1/8	1672
E65Q18L	2014661	65	63.75	55.25	13.31	22.25	4.13	6.00	4.44	5/8 3/4 7/8 1	1148
E65Q18M	2014663	65	63.75	55.25	15.56	22.25	4.13	6.00	4.44	5/8 3/4 7/8 1	1411
E65Q18H	2014664	65	63.75	55.25	17.06	22.25	4.13	6.00	4.44	5/8 3/4 7/8 1	1590
E65QN18L	2014671	65	63.75	55.25	14.06	22.25	4.13	6.00	4.44	5/8 3/4 7/8 1	1213
E65QN18M	2014673	65	63.75	55.25	16.31	22.25	4.13	6.00	4.44	5/8 3/4 7/8 1	1476
E65QN18H	2014674	65	63.75	55.25	17.81	22.25	4.13	6.00	4.44	5/8 3/4 7/8 1	1654
E65QN20L	2014681	65	67.25	58.75	14.06	24.50	4.13	6.00	4.44	3/4 7/8 1, 1-1/8	1384
E65QN20M	2014683	65	67.25	58.75	16.06	24.50	4.13	6.00	4.44	3/4 7/8 1, 1-1/8	1686
E65QN20H	2014684	65	67.25	58.75	17.56	24.50	4.13	6.00	4.44	3/4 7/8 1, 1-1/8	1886
<b>70 Tons</b>											
E70T20L	2014691	70	74.19	65.00	11.14	24.50	5.38	6.69	4.81	3/4 7/8 1, 1-1/8	1379
E70T20M	2014693	70	74.19	65.00	13.14	24.50	5.38	6.69	4.81	3/4 7/8 1, 1-1/8	1681
E70T20H	2014694	70	74.19	65.00	14.64	24.50	5.38	6.69	4.81	3/4 7/8 1, 1-1/8	1881
E70Q18L	2014701	70	70.69	61.50	13.31	22.25	5.38	6.69	4.81	5/8 3/4 7/8 1	1450
E70Q18M	2014703	70	70.69	61.50	15.56	22.25	5.38	6.69	4.81	5/8 3/4 7/8 1	1713
E70Q18H	2014704	70	70.69	61.50	17.06	22.25	5.38	6.69	4.81	5/8 3/4 7/8 1	1892
E70QN18L	2014711	70	70.69	61.50	14.06	22.25	5.38	6.69	4.81	5/8 3/4 7/8 1	1387
E70QN18M	2014713	70	70.69	61.50	16.31	22.25	5.38	6.69	4.81	5/8 3/4 7/8 1	1650
E70QN18H	2014714	70	70.69	61.50	17.81	22.25	5.38	6.69	4.81	5/8 3/4 7/8 1	1829
E70QN20L	2014721	70	74.19	65.00	14.06	24.50	5.38	6.69	4.81	3/4 7/8 1, 1-1/8	1663
E70QN20M	2014723	70	74.19	65.00	16.06	24.50	5.38	6.69	4.81	3/4 7/8 1, 1-1/8	1965
E70QN20H	2014724	70	74.19	65.00	17.56	24.50	5.38	6.69	4.81	3/4 7/8 1, 1-1/8	2165
<b>75 Tons</b>											
E75T20L	2014731	75	74.19	65.00	11.14	24.50	5.38	6.69	4.81	3/4 7/8 1, 1-1/8	1379
E75T20M	2014733	75	74.19	65.00	13.14	24.50	5.38	6.69	4.81	3/4 7/8 1, 1-1/8	1681
E75T20H	2014734	75	74.19	65.00	14.64	24.50	5.38	6.69	4.81	3/4 7/8 1, 1-1/8	1881
E75Q18L	2014741	75	70.69	61.50	13.31	22.25	5.38	6.69	4.81	5/8 3/4 7/8 1	1450
E75Q18M	2014743	75	70.69	61.50	15.56	22.25	5.38	6.69	4.81	5/8 3/4 7/8 1	1713
E75Q18H	2014744	75	70.69	61.50	17.06	22.25	5.38	6.69	4.81	5/8 3/4 7/8 1	1892
E75QN18L	2014751	75	70.69	61.50	14.06	22.25	5.38	6.69	4.81	5/8 3/4 7/8 1	1387
E75QN18M	2014753	75	70.69	61.50	16.31	22.25	5.38	6.69	4.81	5/8 3/4 7/8 1	1650
E75QN18H	2014754	75	70.69	61.50	17.81	22.25	5.38	6.69	4.81	5/8 3/4 7/8 1	1829
E75QN20L	2014761	75	74.19	65.00	14.06	24.50	5.38	6.69	4.81	3/4 7/8 1, 1-1/8	1663
E75QN20M	2014763	75	74.19	65.00	16.06	24.50	5.38	6.69	4.81	3/4 7/8 1, 1-1/8	1965
E75QN20H	2014764	75	74.19	65.00	17.56	24.50	5.38	6.69	4.81	3/4 7/8 1, 1-1/8	2165
<b>80 Tons</b>											
E80T20L	2014771	80	74.19	65.00	11.14	24.50	5.38	6.69	4.81	3/4 7/8 1, 1-1/8	1379
E80T20M	2014773	80	74.19	65.00	13.14	24.50	5.38	6.69	4.81	3/4 7/8 1, 1-1/8	1681
E80T20H	2014774	80	74.19	65.00	14.64	24.50	5.38	6.69	4.81	3/4 7/8 1, 1-1/8	1881
E80Q18L	2014781	80	70.69	61.50	13.31	22.25	5.38	6.69	4.81	5/8 3/4 7/8 1	1450
E80Q18M	2014783	80	70.69	61.5	15.56	22.25	5.38	6.69	4.81	5/8 3/4 7/8 1	1713
E80Q18H	2014784	80	70.69	61.5	17.06	22.25	5.38	6.69	4.81	5/8 3/4 7/8 1	1892
E80QN18L	2014791	80	70.69	61.5	14.06	22.25	5.38	6.69	4.81	5/8 3/4 7/8 1	1387
E80QN18M	2014793	80	70.69	61.5	16.31	22.25	5.38	6.69	4.81	5/8 3/4 7/8 1	1650
E80QN18H	2014794	80	70.69	61.5	17.81	22.25	5.38	6.69	4.81	5/8 3/4 7/8 1	1829
E80QN20L	2014801	80	74.19	65.00	14.06	24.50	5.38	6.69	4.81	3/4 7/8 1, 1-1/8	1663
E80QN20M	2014803	80	74.19	65.00	16.06	24.50	5.38	6.69	4.81	3/4 7/8 1, 1-1/8	1965
E80QN20H	2014804	80	74.19	65.00	17.56	24.50	5.38	6.69	4.81	3/4 7/8 1, 1-1/8	2165

\* Ultimate Load is 4 times the Working Load Limit.

† Additional cheek weight kits are available.



# Innovative McKissick Split-Nut® Retention System Makes Inspection Easier

## Crane Block Hook Inspection in 4 Easy Steps

### STEP 1

Remove protective vinyl cover



### STEP 2

Remove retaining ring

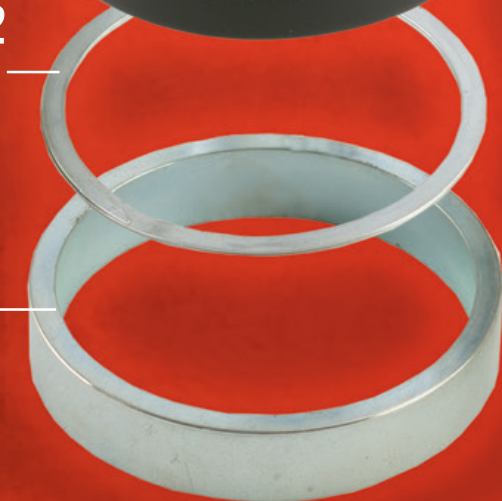

### STEP 3

Slide keeper ring off split nuts



### STEP 4

Easily remove split nut halves to inspect shank hook

Shank hooks on crane blocks must be inspected in accordance with applicable ASME B30, CSA Z150 and other crane standards. These standards mandate the crane hook to be inspected for surface indications, damage and corrosion which could compromise the integrity of the crane block. Because of the type of environment in which these hooks are required to perform, the removal of corroded nuts from the threads can become a problem during inspections. The innovative patented\* Split-Nut Retention System featured on McKissick® crane blocks makes inspection easier. With 4 easy steps, the hook can be disassembled, inspected and put back into service in a fraction of the time of a conventional threaded nut.

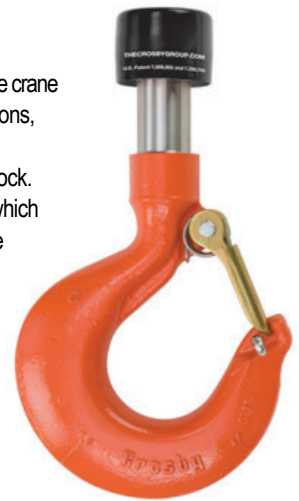

**Fatigue Rated**

**The Split-Nut is standard equipment on McKissick® Easy Reeve® crane blocks up to 100 tons.**

- Allows for easy inspection as required by ASME B30, CSA Z150 and other crane standards
- Eliminates conventional threaded nut and problems associated with the nut removal for inspection.
- Allows repeated installation and removal without risk of damage to hook/nut interface.
- Zinc plated finish for corrosion resistance
- Replacement hook and trunnion assemblies available for selected McKissick® 380, or Easy Reeve® & 790 blocks with threaded hooks.

The new patented\* Split-Nut can be purchased in a variety of configurations that can be used to retrofit the following McKissick® blocks in the field or in the shop

- Over 100 Tons and larger crane blocks, upon request
- Bridge crane blocks
- 80 Series tubing blocks

In addition, the Split-Nut can be used to replace existing hooks on existing crane blocks currently in the field (most manufacturers' makes and models) and on special designed lifting equipment.

**McKISSICK®**  
Your Total Block Company

**Crosby®**

Tulsa, Oklahoma • (918) 834-4611  
thecrosbygroup.com

\* U.S. Patent 7,000,905 & 7,293,763



**B**lock Systems for offshore pedestal-mounted cranes certified to API 2C are considered critical components. McKissick provides blocks, overhaul balls, sheaves, button spelter sockets and wedge sockets that meet the critical compound requirements of API 2C to required Cv values. (It is the responsibility of the crane manufacturer to license or certify these components.)



**MCKISSICK PROVIDES BLOCKS**

Material traceability, chemistry reports, tensile test reports, magnetic particle inspection per ASTM E-709 on the following components: HOOK, HOOK NUT, TRUNNION, CENTER PIN, SIDE PLATE, SHEAVE (no MPI on sheave) and DEAD END.

CHARPY IMPACT TEST REPORTS PER API 2C LATEST REVISION ON HOOK, HOOK NUT, TRUNNION, CENTER PIN, SIDE PLATE AND DEAD END.

Sheave diameter based on D/d ratio based on pitch equal to a minimum of 18/1. Weight plates produced from plate steel. Hook to rotate on thrust bearing with grease fitting. Sheave bearing to be roller bearings with grease fitting

May be proof tested to 2X the rated working load limit.



**MCKISSICK PROVIDES OVERHAUL BALLS**

Material traceability, chemistry, tensile test, magnetic particle inspection per ASTM E-709 on the following components: SWIVEL EYE, FIXED EYE, SWIVEL EYE NUT, SWIVEL BASE PLUG, CASE PIN, HOOK PIN and HOOK.

CHARPY IMPACT TEST REPORTS PER API 2C LATEST REVISION ON SWIVEL EYE, FIXED EYE, SWIVEL EYE NUT, SWIVEL BASE PLUG, CASE PIN, HOOK PIN, AND HOOK.

Eye to rotate on thrust bearing with grease fitting

May be proof tested to 2x the rated Working Load Limit.



**MCKISSICK PROVIDES WEDGE SOCKETS 421 AND 422 UP TO 1-1/4”**

Material traceability, chemistry, tensile test, magnetic particle inspection per ASTM E-709 on the following components: SOCKET BODY and PIN.

CHARPY IMPACT TEST WITH REPORTS ON SOCKET BODY AND PIN. TESTING TO BE PERFORMED PER API 2C LATEST REVISION.

Reference page 462 to assist in proper specification



Crosby QUIC-TAG™

www.thecrosbygroup.com



## THE NEWEST ADDITION TO CROSBY'S RFID TAG FAMILY: QUIC-TAG™

Industry standards require periodic performance inspections to make sure lifting equipment is performing to specified levels. The Crosby QUIC-TAG™ makes the inspection process more efficient, and its unique design can be retrofitted on numerous products.

### Features

- Easy, fast and secure attachment
- Engineered for extreme durability and strength with a low profile design
- Resistant to harsh environmental conditions including exposure to UV rays, water chemical exposure and temperatures up to 185°F (85°C)
- Compatible with the Crosby QUIC-CHECK® Inspection and Identification System
- The most cost effective RFID tag offered by Crosby®



RFID chip



Shown Actual Size

7.625"  
193.675 mm





# Setting a World-Class Standard in Subsea Lifting

Crosby® is a trusted partner in the subsea industry, priding ourselves on being the leading innovator with quality service to back it up. We understand that the unique needs and demanding applications involved in subsea work require products and training that are time-tested and proven.



**Offshore Platform Applications**



**Underwater / Subsea ROV Applications**

# McKissick® Scrap Handling Blocks



**381-SY**  
Scrap Handling  
Blocks

- All single point shank hooks are genuine Crosby®, forged alloy steel, Quenched and Tempered, and have the patented **QUIC-CHECK®** markings.
- Durable - Allows longer continuous duty cycle.
- Can be used with magnet and drop ball.
- Single sheave design.
- Dual action hook (Swings and Rotates).
- Utilizes McKissick® Roll-Forged sheaves with flame hardened grooves.
- Furnished standard with Bronze Bushed Sheaves.
- Optional Tapered Roller Bearings.
- All sizes are **RFID EQUIPPED**.

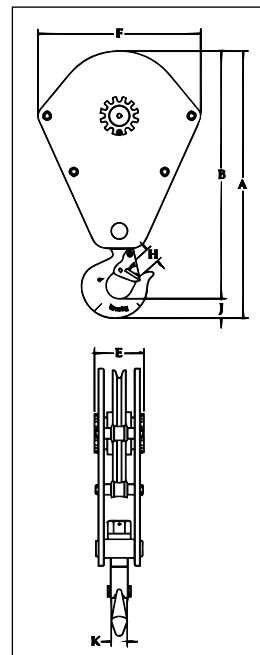

## 381-SY Scrap Handling Blocks

Model No.	381-SY Inquiry Stock No.	Working Load Limit (Tons)*	Sheave Diameter (in)	Standard Wireline (in)	Weight Each	Dimensions (in)						
						A	B	E	F	H	J	K
S15S16L	2014810	15	16	9/16, 5/8, 3/4, 7/8	285	37.16	34.19	6.34	22.75	2.75	2.97	2.38
S20S18L	2014812	20	18	5/8, 3/4, 7/8, 1	395	39.54	36.57	6.84	24.75	2.75	2.97	2.38
S25S20L	2014814	25	20	3/4, 7/8, 1, 1-1/8	460	42.16	39.19	6.84	26.75	2.75	2.97	2.38
S30S24L	2014816	30	24	7/8, 1, 1-1/8, 1-1/4	705	50.44	46.81	7.84	30.75	3.25	3.62	3.00
S40S24L	2014818	40	24	7/8, 1, 1-1/8, 1-1/4	815	55.81	50.75	7.84	30.75	3.38	5.06	3.25

\* Ultimate Load is 4 times the Working Load Limit.

McKissick  
Blocks





TU-481

- **Wide Range of Sizes Available:**
  - 30 and 60 Ton Capacity
  - 1" to 2-1/4" Wireline Size
  - 16" to 24" Sheave Diameter
  - Larger Capacity Blocks available.
- **Multiple Configurations Available:**
  - Swivel Shackle
  - Tailboard
  - Upset Shackle
  - Fixed Shackle
- **McKissick Roll-Forged Sheaves:**
  - Flame Hardened Grooves
  - 30 Ton furnished with Roller Bearings
  - 60 Ton furnished with Tapered Roller Bearings with seals

- Meets or exceeds all requirements of ASME B30.26 including identification, ductility, design factor, proof load and temperature requirements. Importantly, these blocks meet other critical performance requirements including fatigue life, impact properties and material traceability, not addressed by ASME B30.26.



All sizes are  
RFID EQUIPPED

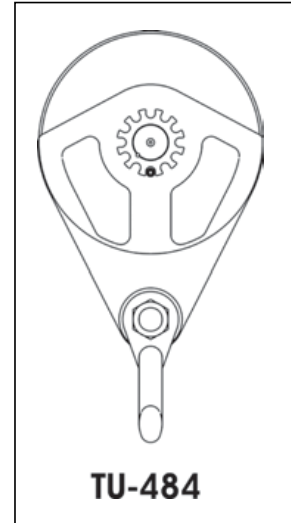
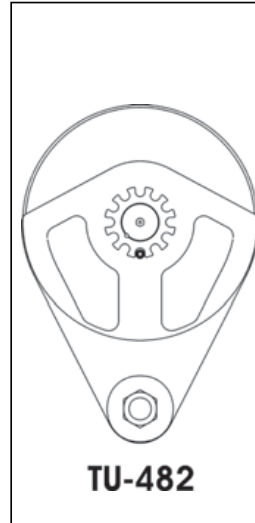
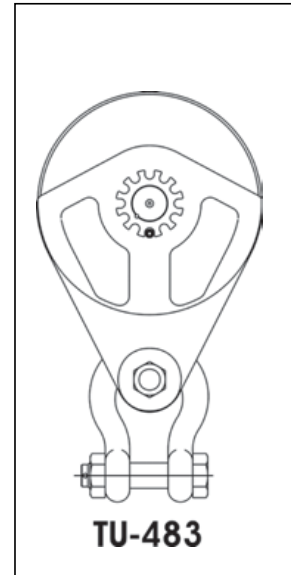
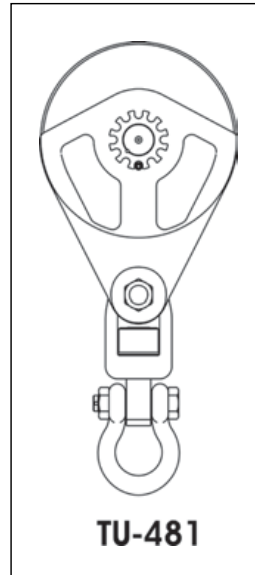

**TU-481 / TU-482 / TU-483 / TU-484**  
High Capacity Snatch Blocks for Tilt-Up Wall Construction

Working Load Limit (Tons)*	Sheave Diameter (in)	Wire Line Size (in)	With Swivel Shackle		Tailboard Style		With Upset Shackle		With Fixed Shackle	
			TU-481 Stock No.	TU-481 Weight Each (lb)	TU-482 Stock No.	TU-482 Weight Each (lb)	TU-483 Stock No.	TU-483 Weight Each (lb)	TU-484 Stock No.	TU-484 Weight Each (lb)
30	16"	1" - 1-1/4"	2108327	235	2108330	140	2108333	180	2108651	160
30	16"	1-1/4" - 1-1/2"	2108351	235	2108354	140	2108357	180	2108657	160
30	20"	1" - 1-1/4"	2108387	250	2108390	155	2108393	195	2108666	175
30	20"	1-1/4" - 1-1/2"	2108411	250	2108414	155	2108417	195	2108672	175
60	18"	1" - 1-1/4"	2108453	390	2108456	230	2108459	340	2108462	290
60	18"	1-1/4" - 1-1/2"	2108483	390	2108486	230	2108489	340	2108492	290
60	24"	1" - 1-1/4"	2108528	450	2108531	290	2108534	400	2108537	350
60	24"	1-1/4" - 1-1/2"	2108558	450	2108561	290	2108564	400	2108567	350
60	24"	1-1/2" - 1-3/4"	2108588	450	2108591	290	2108594	400	2108597	350
60	24"	1-3/4" - 2"	2108618	450	2108621	290	2108624	400	2108627	350
60	24"	2" - 2-1/4"	2108633	450	2108636	290	2108639	400	2108642	350

\* Ultimate Load is 4 times the Working Load Limit.

Contact our Block Hotline (800)772-1555 for larger capacity blocks up to 350 Tons or reference the special request form on page 461.





**680**  
Construction Block  
with Shackle



**680**  
Construction Block  
with Hanger



**680**  
Construction Block  
Bolt only



## 680 Construction Blocks

- Wide Range of products available.
- Capacity: 5 to 100 Tons – Larger models available.
- Sheave sizes: 6" to 24" O.D.
- Wireline Sizes: 3/8" to 1-1/4"
- Equipped with genuine Crosby® forged steel, Quenched and Tempered shackles that contain the patented **QUIC-CHECK®** markings.
- Design Factor of 4:1.
- All 680 Series Blocks are furnished standard with Bronze Bushings.
- All 680 blocks 16" and larger, are furnished with McKissick® Roll-Forged sheaves with flame hardened grooves
- Sheaves are lubricated through center pin, with a separate lube channel to each bearing.
- Single sheave blocks have thimble dead end.
- Manufactured by an ISO 9001 and API Q1 Certified facility .
- Meets or exceeds all requirements of ASME B30.26 including identification, ductility, design factor, proof load and temperature requirements. Importantly, these blocks meet other critical performance requirements including fatigue life, impact properties and material traceability, not addressed by ASME B30.26.

### OPTIONS AVAILABLE

- Roller bearing sheaves
- Hanger and Bolt Only models available
- Third party testing with certification
- Galvanized finish – Most model

## “P” Fitting – Block with Bolt Only

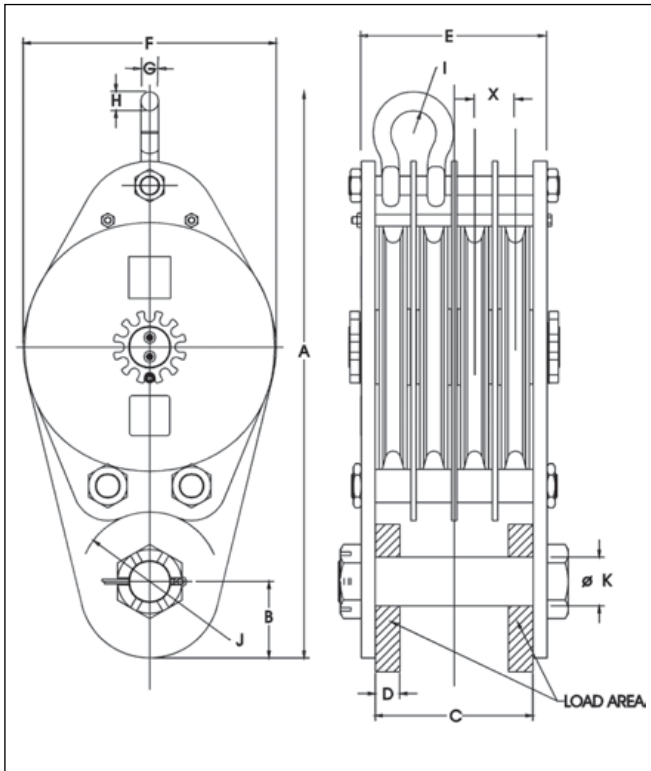

## “H” Fitting – Block with Hanger Only

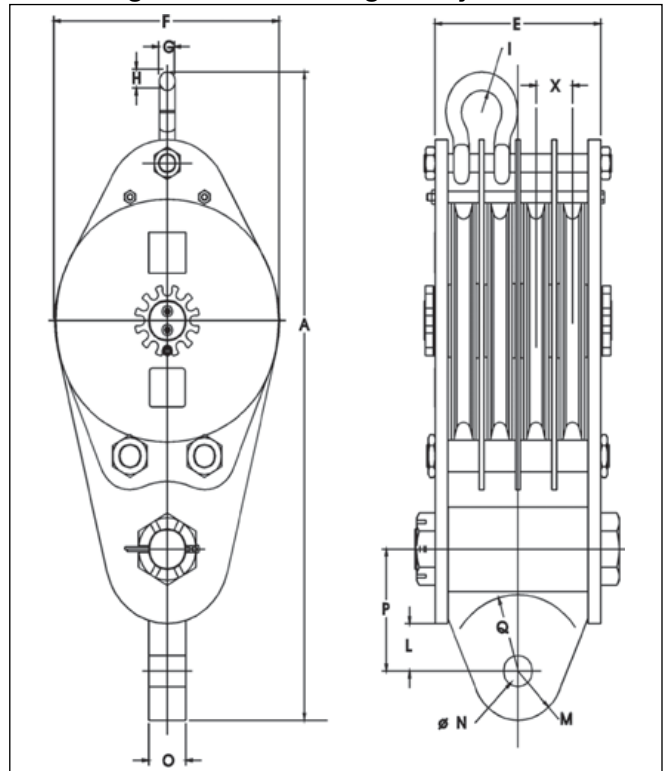

## Block Loading Area

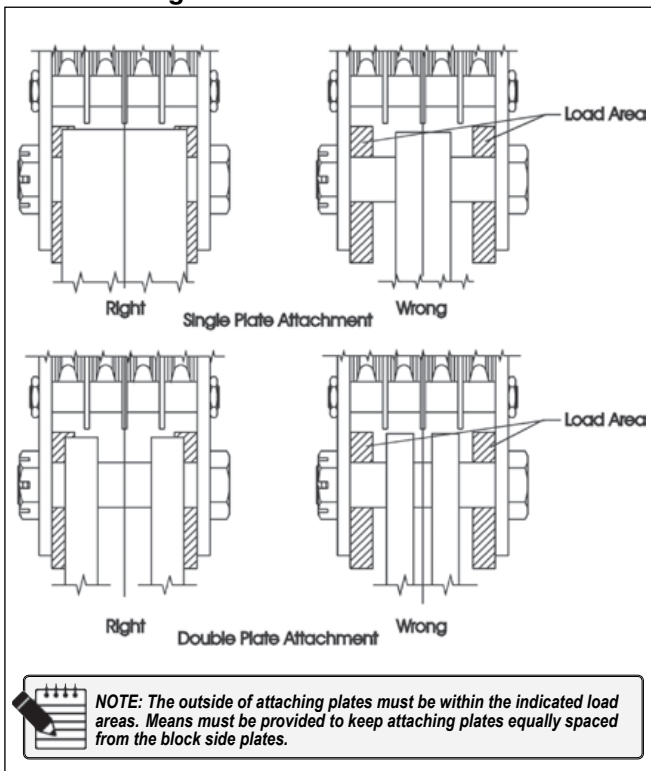

## “S” Fitting – Block with Hanger and Shackle

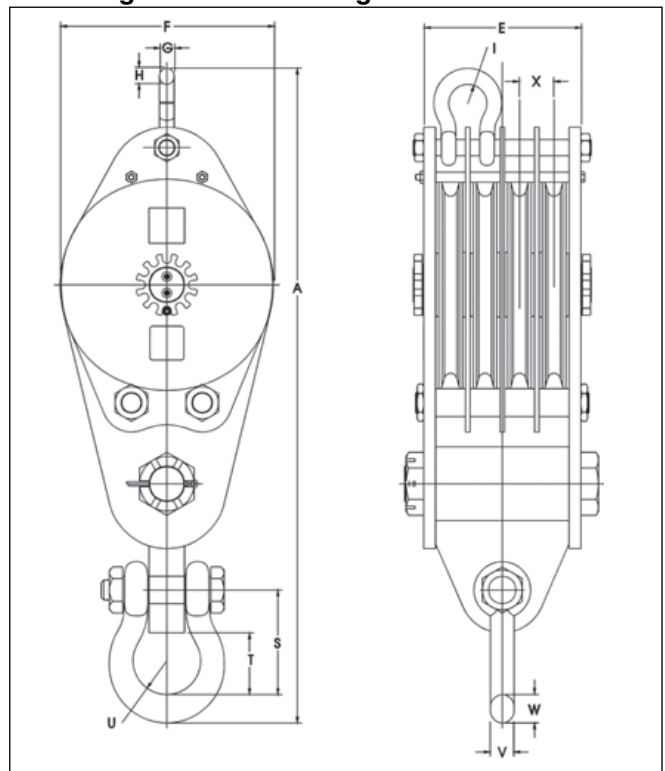



**680 BLOCKS – “P” FITTING**

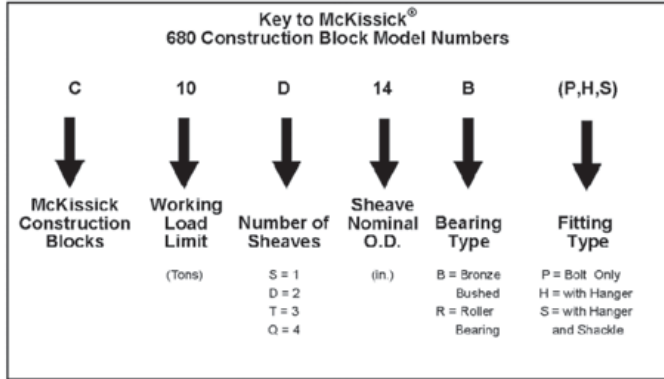

Sheave Diameter (in.)	WireLine Size (in.)									
	3/8	7/16	1/2	9/16	5/8	3/4	7/8	1	1-1/8	1-1/4
6										
8										
10										
12										
14										
16										
18										
20										
24										



All sizes are RFID EQUIPPED.

**680 Blocks – “P” Fitting – Blocks with Bolt Only – See Drawing on Page 339**

Model No.	680-P Inquiry Stock No.	Working Load Limit (Tons)	No. of Sheaves	Sheave Diam. (in.)	Dimensions (in.)												Weight Each (lb)
					A	B	C	D	E	F	G	H	I	J	K	X	
<b>5 Tons</b>																	
C5S6BP	2101000	5	1	6	12.12	1.62	1.78	-	2.28	6.12	-	-	-	2.00	1.25	-	19
C5S8BP	2101002	5	1	8	14.00	1.62	1.78	-	2.28	8.12	-	-	-	2.00	1.25	-	31
C5D6BP	2101010	5	2	6	14.75	1.62	3.81	1.06	4.31	6.12	.63	.69	.84	1.79	1.25	2.03	33
C5D8BP	2101012	5	2	8	16.62	1.62	3.81	1.06	4.31	8.12	.63	.69	.84	1.79	1.25	2.03	54
C5T6BP	2101020	5	3	6	14.75	1.62	5.84	1.06	6.34	6.12	.63	.69	.84	1.79	1.25	2.03	45
C5T8BP	2101022	5	3	8	16.62	1.62	5.84	1.06	6.34	8.12	.63	.69	.84	1.79	1.25	2.03	75
<b>7.5 Tons</b>																	
C7S6BP	2101050	7.5	1	6	12.12	1.62	1.78	-	2.28	6.12	-	-	-	2.00	1.25	-	19
C7S8BP	2101052	7.5	1	8	14.00	1.62	1.78	-	2.28	8.12	-	-	-	2.00	1.25	-	31
C7D6BP	2101060	7.5	2	6	14.75	1.62	3.81	.62	4.31	6.12	.63	.69	.84	1.79	1.25	2.03	33
C7D8BP	2101062	7.5	2	8	16.62	1.62	3.81	.62	4.31	8.12	.63	.69	.84	1.79	1.25	2.03	54
C7T6BP	2101070	7.5	3	6	14.75	1.62	5.84	.62	6.34	6.12	.63	.69	.84	1.79	1.25	2.03	45
C7T8BP	2101072	7.5	3	8	16.62	1.62	5.84	.62	6.34	8.12	.63	.69	.84	1.79	1.25	2.03	75
<b>10 Tons</b>																	
C10S8BP	2101100	10	1	8	15.12	2.12	1.78	-	2.28	8.12	-	-	-	2.38	1.50	-	34
C10S10BP	2101102	10	1	10	17.12	2.12	1.78	-	2.28	10.12	-	-	-	2.38	1.50	-	47
C10S12BP	2101104	10	1	12	19.00	2.12	1.78	-	2.28	12.12	-	-	-	2.38	1.50	-	57
C10S14BP	2101106	10	1	14	21.12	2.12	1.78	-	2.28	14.12	-	-	-	2.38	1.50	-	64
C10D6BP	2101110	10	2	6	15.69	2.12	3.81	.88	4.31	6.12	.63	.69	.84	2.12	1.50	2.03	41
C10D8BP	2101112	10	2	8	17.44	2.12	3.81	.88	4.31	8.12	.63	.69	.84	2.12	1.50	2.03	58
C10D10BP	2101114	10	2	10	19.44	2.12	3.81	.88	4.31	10.12	.63	.69	.84	2.12	1.50	2.03	82
C10D12BP	2101116	10	2	12	21.31	2.12	3.81	.88	4.31	12.12	.63	.69	.84	2.12	1.50	2.03	99
C10D14BP	2101118	10	2	14	23.44	2.12	3.81	.88	4.31	14.12	.63	.69	.84	2.12	1.50	2.03	114
C10T8BP	2101120	10	3	8	17.44	2.12	5.84	.88	6.34	8.12	.63	.69	.84	2.12	1.50	2.03	81
C10T10BP	2101122	10	3	10	19.44	2.12	5.84	.88	6.34	10.12	.63	.69	.84	2.12	1.50	2.03	115
C10T12BP	2101124	10	3	12	21.31	2.12	5.84	.88	6.34	12.12	.63	.69	.84	2.12	1.50	2.03	138
C10T14BP	2101126	10	3	14	23.44	2.12	5.84	.88	6.34	14.12	.63	.69	.84	2.12	1.50	2.03	162
C10Q8BP	2101130	10	4	8	17.44	2.12	7.87	.88	8.37	8.12	.63	.69	.84	2.12	1.50	2.03	103
C10Q10B	2101132	10	4	10	19.44	2.12	7.87	.88	8.37	10.12	.63	.69	.84	2.12	1.50	2.03	149
<b>15 Tons</b>																	
C15S10B	2101170	15	1	10	19.19	2.88	2.04	-	3.04	10.12	-	-	-	3.12	2.00	-	76
C15S12BP	2101172	15	1	12	21.06	2.88	2.04	-	3.04	12.12	-	-	-	3.12	2.00	-	92
C15S14SP	2101174	15	1	14	23.06	2.88	2.04	-	3.04	14.12	-	-	-	3.12	2.00	-	111
C15D10BP	2101180	15	2	10	22.19	2.88	4.34	1.25	5.34	10.12	.75	.81	1.00	2.82	2.00	2.30	115
C15D12BP	2101182	15	2	12	24.06	2.88	4.34	1.25	5.34	12.12	.75	.81	1.00	2.82	2.00	2.30	138
C15D14BP	2101184	15	2	14	26.06	2.88	4.34	1.25	5.34	14.12	.75	.81	1.00	2.82	2.00	2.30	168
C15T8BP	2101190	15	3	8	20.19	2.88	6.64	1.25	7.64	8.12	.75	.81	1.00	2.82	2.00	2.30	105
C15T10BP	2101192	15	3	10	22.19	2.88	6.64	1.25	7.64	10.12	.75	.81	1.00	2.82	2.00	2.30	152
C15T12BP	2101194	15	3	12	24.06	2.88	6.64	1.25	7.64	12.12	.75	.81	1.00	2.82	2.00	2.30	182
C15T14BP	2101196	15	3	14	26.06	2.88	6.64	1.25	7.64	14.12	.75	.81	1.00	2.82	2.00	2.30	214
C15Q10BP	2101200	15	4	10	22.19	2.88	8.94	1.25	9.94	10.12	.75	.81	1.00	2.82	2.00	2.30	209
<b>20 Tons</b>																	
C20S18BP	2101244	20	1	18	27.88	3	2.54	.75	4.04	18.12	-	-	-	3.12	2.00	-	203
C20D12BP	2101250	20	2	12	27.69	3	4.34	.75	5.84	12.12	.88	.97	1.14	2.82	2.00	2.30	166
C20D14BP	2101252	20	2	14	28.5	3	4.34	.75	5.84	14.12	.88	.97	1.14	2.82	2.00	2.30	199

## 680 Blocks –“P” Fitting – Blocks with Bolt Only – See Drawing on Page 339

Model No.	680-P Inquiry Stock No.	Working Load Limit (Tons)	No. of Sheaves	Sheave Diam. (in)	Dimensions (in)													Weight Each (lb)
					A	B	C	D	E	F	G	H	I	J	K	X		
C20D16BP	2101254	20	2	16	30.75	3	4.34	.75	5.84	16.12	.88	.97	1.14	2.82	2.00	2.30	239	
C20T10BP	2101260	20	3	10	24.75	3	6.64	.75	8.14	10.12	.88	.97	1.14	2.82	2.00	2.30	178	
C20T12BP	2101262	20	3	12	26.69	3	6.64	.75	8.14	12.12	.88	.97	1.14	2.82	2.00	2.30	207	
C20T14BP	2101264	20	3	14	28.5	3	6.64	.75	8.14	14.12	.88	.97	1.14	2.82	2.00	2.30	255	
C20T16BP	2101266	20	3	16	30.75	3.00	6.64	.75	8.14	16.12	.88	.97	1.14	2.82	2.00	2.30	309	
C20Q8BP	2101270	20	4	8	22.56	3.00	8.94	.75	10.44	8.12	.88	.97	1.14	2.82	2.00	2.30	171	
C20Q10BP	2101272	20	4	10	24.75	3.00	8.94	.75	10.44	10.12	.88	.97	1.14	2.82	2.00	2.30	219	
C20Q12BP	2101274	20	4	12	26.69	3.00	8.94	.75	10.44	12.12	.88	.97	1.14	2.82	2.00	2.30	262	
C20Q14BP	2101276	20	4	14	28.50	3.00	8.94	.75	10.44	14.12	.88	.97	1.14	2.82	2.00	2.30	312	
<b>25 Tons</b>																		
C25S18BP	2101314	25	1	18	27.88	3.00	2.54	.50	4.04	18.12	-	-	-	3.12	2.00	-	203	
C25D12BP	2101320	25	2	12	27.69	3.00	4.34	.50	5.84	12.12	.88	.97	1.14	2.82	2.00	2.30	167	
C25D14BP	2101322	25	2	14	28.50	3.00	4.34	.50	5.84	14.12	.88	.97	1.14	2.82	2.00	2.30	198	
C25D16BP	2101324	25	2	16	30.75	3.00	4.34	.50	5.84	16.12	.88	.97	1.14	2.82	2.00	2.30	239	
C25T10BP	2101330	25	3	10	24.75	3.00	6.64	.50	8.14	10.12	.88	.97	1.14	2.82	2.00	2.30	178	
C25T12BP	2101332	25	3	12	26.69	3.00	6.64	.50	8.14	12.12	.88	.97	1.14	2.82	2.00	2.30	207	
C25T14BP	2101334	25	3	14	28.50	3.00	6.64	.50	8.14	14.12	.88	.97	1.14	2.82	2.00	2.30	253	
C25T16BP	2101336	25	3	16	30.75	3.00	6.64	.50	8.14	16.12	.88	.97	1.14	2.82	2.00	2.30	309	
C25Q08BP	2101340	25	4	8	22.56	3.00	8.94	.50	10.44	8.12	.88	.97	1.14	2.82	2.00	2.30	168	
C25Q10BP	2101342	25	4	10	24.75	3.00	8.94	.50	10.44	10.12	.88	.97	1.14	2.82	2.00	2.30	222	
C25Q12BP	2101344	25	4	12	26.69	3.00	8.94	.50	10.44	12.12	.88	.97	1.14	2.82	2.00	2.30	262	
C25Q14BP	2101346	25	4	14	28.50	3.00	8.94	.50	10.44	14.12	.88	.97	1.14	2.82	2.00	2.30	312	
<b>30 Tons</b>																		
C30D12BP	2101390	30	2	12	30.12	4.25	5.34	2.06	6.84	12.12	1.00	1.06	1.34	4.20	3.00	2.80	190	
C30D14BP	2101392	30	2	14	32.00	4.25	5.34	2.06	6.84	14.12	1.00	1.06	1.34	4.20	3.00	2.80	226	
C30D16BP	2101394	30	2	16	34.38	4.25	5.34	2.06	6.84	16.12	1.00	1.06	1.34	4.20	3.00	2.80	267	
C30D18BP	2101396	30	2	18	36.12	4.25	5.34	2.06	6.84	18.12	1.00	1.06	1.34	4.20	3.00	2.80	344	
C30T10BP	2101400	30	3	10	28.25	4.25	6.64	2.06	8.14	10.12	1.00	1.06	1.34	4.20	3.00	2.30	213	
C30T12BP	2101402	30	3	12	30.12	4.25	6.64	2.06	8.14	12.12	1.00	1.06	1.34	4.20	3.00	2.30	239	
C30T14BP	2101404	30	3	14	32.00	4.25	6.64	2.06	8.14	14.12	1.00	1.06	1.34	4.20	3.00	2.30	282	
C30T16BP	2101406	30	3	16	34.38	4.25	6.64	2.06	8.14	16.12	1.00	1.06	1.34	4.20	3.00	2.30	343	
C30Q10BP	2101410	30	4	10	36.12	4.25	8.94	2.06	10.44	10.12	1.00	1.06	1.34	4.20	3.00	2.30	255	
C30Q12BP	2101412	30	4	12	30.12	4.25	8.94	2.06	10.44	12.12	1.00	1.06	1.34	4.20	3.00	2.30	291	
C30Q14BP	2101414	30	4	14	32.00	4.25	8.94	2.06	10.44	14.12	1.00	1.06	1.34	4.20	3.00	2.30	342	
C30Q16BP	2101416	30	4	16	34.38	4.25	8.94	2.06	10.44	16.12	1.00	1.06	1.34	4.20	3.00	2.30	417	
<b>35 Tons</b>																		
C35D12BP	2101450	35	2	12	30.12	4.25	5.34	1.69	6.84	12.12	1.00	1.06	1.34	4.20	3.00	2.80	190	
C35D14BP	2101452	35	2	14	32.00	4.25	5.34	1.69	6.84	14.12	1.00	1.06	1.34	4.20	3.00	2.80	225	
C35D16BP	2101454	35	2	16	34.38	4.25	5.34	1.69	6.84	16.12	1.00	1.06	1.34	4.20	3.00	2.80	267	
C35D18BP	2101456	35	2	18	36.12	4.25	5.34	1.69	6.84	18.12	1.00	1.06	1.34	4.20	3.00	2.80	344	
C35T10BP	2101460	35	3	10	28.25	4.25	6.64	1.69	8.14	10.12	1.00	1.06	1.34	4.20	3.00	2.30	213	
C35T12BP	2101462	35	3	12	30.12	4.25	6.64	1.69	8.14	12.12	1.00	1.06	1.34	4.20	3.00	2.30	239	
C35T14BP	2101464	35	3	14	32.00	4.25	6.64	1.69	8.14	14.12	1.00	1.06	1.34	4.20	3.00	2.30	282	
C35T16BP	2101466	35	3	16	34.38	4.25	6.64	1.69	8.14	16.12	1.00	1.06	1.34	4.20	3.00	2.30	343	
C35Q10BP	2101470	35	4	10	36.12	4.25	8.94	1.69	10.44	10.12	1.00	1.06	1.34	4.20	3.00	2.30	255	
C35Q12BP	2101472	35	4	12	30.12	4.25	8.94	1.69	10.44	12.12	1.00	1.06	1.34	4.20	3.00	2.30	291	
C35Q14BP	2101474	35	4	14	32.00	4.25	8.94	1.69	10.44	14.12	1.00	1.06	1.34	4.20	3.00	2.30	342	
C35Q16BP	2101476	35	4	16	34.38	4.25	8.94	1.69	10.44	16.12	1.00	1.06	1.34	4.20	3.00	2.30	417	
<b>40 Tons</b>																		
C40D18BP	2101512	40	2	18	37.00	4.25	5.84	1.25	7.84	18.12	1.13	1.25	1.46	4.20	3.00	3.30	478	
C40D20BP	2101514	40	2	20	38.25	4.25	5.84	1.25	7.84	20.12	1.13	1.25	1.46	4.20	3.00	3.30	567	
C40D24BP	2101516	40	2	24	42.25	4.25	5.84	1.25	7.84	24.12	1.13	1.25	1.46	4.20	3.00	3.30	746	
C40T14BP	2101520	40	3	14	34.25	5.00	6.64	1.25	8.14	14.12	1.13	1.25	1.46	4.20	3.00	2.30	300	
C40T16BP	2101522	40	3	16	36.50	5.00	6.64	1.25	8.14	16.12	1.13	1.25	1.46	4.20	3.00	2.30	359	
C40T18BP	2101524	40	3	18	37.00	4.25	8.4	1.25	10.40	18.12	1.13	1.25	1.46	4.20	3.00	2.90	581	
C40T20BP	2101526	40	3	20	38.25	4.25	8.4	1.25	10.40	20.12	1.13	1.25	1.46	4.20	3.00	2.90	691	
C40Q12BP	2101530	40	4	12	32.38	5.00	8.94	1.25	10.44	12.12	1.13	1.25	1.46	4.20	3.00	2.30	318	
C40Q14BP	2101532	40	4	14	34.25	5.00	8.94	1.25	10.44	14.12	1.13	1.25	1.46	4.20	3.00	2.30	362	
C40Q16BP	2101534	40	4	16	36.50	5.00	8.94	1.25	10.44	16.12	1.13	1.25	1.46	4.20	3.00	2.30	430	
C40Q18BP	2101536	40	4	18	37.00	4.25	11.33	1.25	13.33	18.12	1.13	1.25	1.46	4.20	3.00	2.90	683	
<b>45 Tons</b>																		
C45D18BP	2101582	45	2	18	37.00	4.25	5.84	1.00	7.84	18.12	1.13	1.25	1.46	4.20	3.00	3.30	478	
C45D20BP	2101584	45	2	20	38.25	4.25	5.84	1.00	7.84	20.12	1.13	1.25	1.46	4.20	3.00	3.30	567	
C45D24BP	2101586	45	2	24	42.25	4.25	5.84	1.00	7.84	24.12	1.13	1.25	1.46	4.20	3.00	3.30	746	
C45T14BP	2101590	45	3	14	34.25	5.00	6.64	1.00	8.14	14.12	1.13	1.25	1.46	4.20	3.00	2.30	300	
C45T16BP	2101592	45	3	16	36.50	5.00	6.64	1.00	8.14	16.12	1.13	1.25	1.46	4.20	3.00	2.30	359	
C45T18BP	2101594	45	3	18	37.00	4.25	8.4	1.00	10.40	18.12	1.13	1.25	1.46	4.20	3.00	2.90	581	
C45T20BP	2101596	45	3	20	38.25	4.25	8.4	1.00	10.40	20.12	1.13	1.25	1.46	4.20	3.00	2.90	691	
C45Q12BP	2101600	45	4	12	32.38	5.00	8.94	1.00	10.44	12.12	1.13	1.25	1.46	4.20	3.00	2.30	318	
C45Q14BP	2101602	45	4	14	34.25	5.00	8.94	1.00	10.44	14.12	1.13	1.25	1.46	4.20	3.00	2.30	362	
C45Q16BP	2101604	45	4	16	36.50	5.00	8.94	1.00	10.44	16.12	1.13	1.25	1.46	4.20	3.00	2.30	430	

McKissick Blocks

680 Blocks – “P” Fitting – Blocks with Bolt Only – See Drawing on Page 339

Model No.	680-P Inquiry Stock No.	Working Load Limit (Tons)	No. of Sheaves	Sheave Diam. (in)	Dimensions (in)													Weight Each (lb)
					A	B	C	D	E	F	G	H	I	J	K	X		
C45Q18BP	2101606	45	4	18	37.00	4.25	11.33	1.00	13.33	18.12	1.13	1.25	1.46	4.20	3.00	2.90	683	
<b>50 Tons</b>																		
C50D20BP	2101640	50	2	20	42.00	5.50	5.84	1.75	7.84	20.12	1.25	1.38	1.62	4.89	3.50	3.30	614	
C50D24BP	2101642	50	2	24	46.00	5.50	5.84	1.75	7.84	24.12	1.25	1.38	1.62	4.89	3.50	3.30	797	
C50T18BP	2101650	50	3	18	40.75	5.50	8.40	1.75	10.40	18.12	1.25	1.38	1.62	4.89	3.50	2.90	598	
C50T20BP	2101652	50	3	20	42.00	5.50	8.40	1.75	10.40	20.12	1.25	1.38	1.62	4.89	3.50	2.90	710	
C50T24BP	2101654	50	3	24	46.00	5.50	8.40	1.75	10.40	24.12	1.25	1.38	1.62	4.89	3.50	2.90	923	
C50Q16BP	2101660	50	4	16	38.62	5.50	11.33	1.75	13.33	16.12	1.25	1.38	1.62	4.89	3.50	2.90	598	
C50Q18BP	2101662	50	4	18	40.75	5.50	11.33	1.75	13.33	18.12	1.25	1.38	1.62	4.89	3.50	2.90	748	
<b>55 Tons</b>																		
C55D20BP	2101700	55	2	20	42.00	5.50	5.84	1.56	7.84	20.12	1.25	1.38	1.62	4.89	3.50	3.30	614	
C55D24BP	2101702	55	2	24	46.00	5.50	5.84	1.56	7.84	24.12	1.25	1.38	1.62	4.89	3.50	3.30	797	
C55T18BP	2101710	55	3	18	40.75	5.50	8.40	1.56	10.40	18.12	1.25	1.38	1.62	4.89	3.50	2.90	598	
C55T20BP	2101712	55	3	20	42.00	5.50	8.40	1.56	10.40	20.12	1.25	1.38	1.62	4.89	3.50	2.90	710	
C55T24BP	2101714	55	3	24	46.00	5.50	8.40	1.56	10.40	24.12	1.25	1.38	1.62	4.89	3.50	2.90	923	
C55Q16BP	2101720	55	4	16	38.62	5.50	11.33	1.56	13.33	16.12	1.25	1.38	1.62	4.89	3.50	2.90	598	
C55Q18BP	2101722	55	4	18	40.75	5.50	11.33	1.56	13.33	18.12	1.25	1.38	1.62	4.89	3.50	2.90	748	
<b>60 Tons</b>																		
C60T18BP	2101760	60	3	18	40.75	5.50	8.40	1.38	10.40	18.12	1.25	1.38	1.62	4.89	3.50	2.90	598	
C60T20BP	2101762	60	3	20	42.00	5.50	8.40	1.38	10.40	20.12	1.25	1.38	1.62	4.89	3.50	2.90	710	
C60T24BP	2101764	60	3	24	46.00	5.50	8.40	1.38	10.40	24.12	1.25	1.38	1.62	4.89	3.50	2.90	923	
C60Q18BP	2101770	60	4	18	40.75	5.50	11.33	1.38	13.33	18.12	1.25	1.38	1.62	4.89	3.50	2.90	748	
C60Q20BP	2101772	60	4	20	42.00	5.50	11.33	1.38	13.33	20.12	1.25	1.38	1.62	4.89	3.50	2.90	898	
C60Q24BP	2101774	60	4	24	46.00	5.50	11.33	1.38	13.33	24.12	1.25	1.38	1.62	4.89	3.50	2.90	1108	
<b>65 Tons</b>																		
C65T18BP	2101810	65	3	18	40.75	5.50	8.40	1.19	10.40	18.12	1.25	1.38	1.62	4.89	3.50	2.90	598	
C65T20BP	2101812	65	3	20	42.00	5.50	8.40	1.19	10.40	20.12	1.25	1.38	1.62	4.89	3.50	2.90	710	
C65T24BP	2101814	65	3	24	46.00	5.50	8.40	1.19	10.40	24.12	1.25	1.38	1.62	4.89	3.50	2.90	923	
C65Q18BP	2101820	65	4	18	40.75	5.50	11.33	1.19	13.33	18.12	1.25	1.38	1.62	4.89	3.50	2.90	748	
C65Q20BP	2101822	65	4	20	42.00	5.50	11.33	1.19	13.33	20.12	1.25	1.38	1.62	4.89	3.50	2.90	898	
C65Q24BP	2101824	65	4	24	46.00	5.50	11.33	1.19	13.33	24.12	1.25	1.38	1.62	4.89	3.50	2.90	1108	
<b>70 Tons</b>																		
C70T20BP	2101830	70	3	20	46.25	7.00	9.14	1.75	11.14	20.12	1.38	1.50	1.82	5.58	4.00	3.30	890	
C70Q20BP	2101840	70	4	20	46.25	7.00	11.31	1.75	13.31	20.12	1.38	1.50	1.82	5.58	4.00	2.90	935	
C70Q24BP	2101842	70	4	24	50.25	7.00	11.31	1.75	13.31	24.12	1.38	1.50	1.82	5.58	4.00	2.90	1260	
C70QN20BP	2101850	70	5	20	46.25	7.00	9.14	1.75	18.23	20.12	1.38	1.50	1.82	5.58	4.00	3.30	1305	
C70QN24BP	2101852	70	5	24	50.25	7.00	9.14	1.75	18.23	24.12	1.38	1.50	1.82	5.58	4.00	3.30	1715	
<b>80 Tons</b>																		
C80T20BP	2101860	80	3	20	46.25	7.00	9.14	1.44	11.14	20.12	1.38	1.50	1.82	5.58	4.00	3.30	890	
C80Q20BP	2101870	80	4	20	46.25	7.00	11.31	1.44	13.31	20.12	1.38	1.50	1.82	5.58	4.00	2.90	1000	
C80Q24BP	2101872	80	4	24	50.25	7.00	11.31	1.44	13.31	24.12	1.38	1.50	1.82	5.58	4.00	2.90	1260	
C80QN20BP	2101880	80	5	20	46.25	7.00	9.14	1.44	18.23	20.12	1.38	1.50	1.82	5.58	4.00	3.30	1305	
C80QN24BP	2101882	80	5	24	50.25	7.00	9.14	1.44	18.23	24.12	1.38	1.50	1.82	5.58	4.00	3.30	1715	
<b>90 Tons</b>																		
C90Q20BP	2101920	90	4	20	46.25	7.50	11.31	1.19	13.81	20.12	1.38	1.50	1.82	5.58	4.00	2.90	1060	
C90Q24BP	2101922	90	4	24	50.75	7.50	11.31	1.19	13.81	24.12	1.38	1.50	1.82	5.58	4.00	2.90	1420	
C90QN20BP	2101930	90	5	20	46.75	7.50	9.14	1.19	18.23	20.12	1.38	1.50	1.82	5.58	4.00	3.30	1305	
C90QN24BP	2101932	90	5	24	50.75	7.50	9.14	1.19	18.23	24.12	1.38	1.50	1.82	5.58	4.00	3.30	1775	
<b>100 Tons</b>																		
C100QN20BP	2101970	100	5	20	46.75	7.50	9.14	1.00	18.23	20.12	1.38	1.50	1.82	5.58	4.00	3.30	1305	
C100QN24BP	2101972	100	5	24	50.75	7.50	9.14	1.00	18.23	24.12	1.38	1.50	1.82	5.58	4.00	3.30	1775	
C100SX20BP	2101980	100	6	20	46.75	7.50	11.31	1.00	20.41	20.12	1.38	1.50	1.82	5.58	4.00	2.90	1365	
C100SX24BP	2101982	100	6	24	50.75	7.50	11.31	1.00	20.41	24.12	1.38	1.50	1.82	5.58	4.00	2.90	1855	

## 680 BLOCKS – “H” FITTING

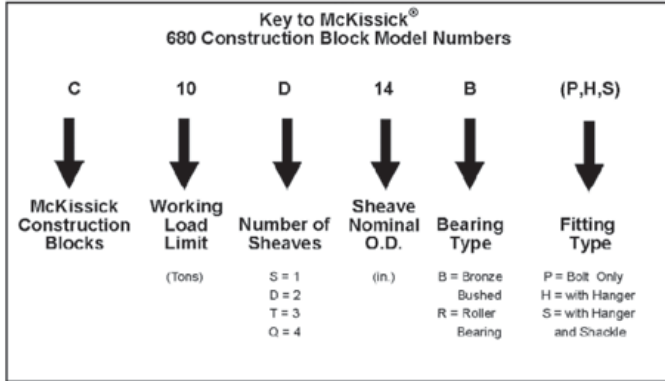

Sheave Diameter (in.)	WireLine Size (in.)									
	3/8	7/16	1/2	9/16	5/8	3/4	7/8	1	1-1/8	1-1/4
6										
8										
10										
12										
14										
16										
18										
20										
24										



All sizes are RFID EQUIPPED.

### 680 Blocks – “H” Fitting – Blocks with Hanger – See Drawing on Page 339

Model No.	680-H Inquiry Stock No.	Working Load Limit (Tons)	No. of Sheaves	Sheave Diam. (in.)	Dimensions (in.)													Weight Each (lb)
					A	E	F	G	H	I	L	M	N	O	P	Q	X	
<b>5 Tons</b>																		
C5S6BH	2102000	5	1	6	15.00	2.28	6.12	-	-	-	1.63	1.25	1.06	1.16	3.25	1.86	-	22
C5S8BH	2102002	5	1	8	16.88	2.28	8.12	-	-	-	1.63	1.25	1.06	1.16	3.25	1.86	-	34
C5D6BH	2102010	5	2	6	17.62	4.31	6.12	.63	.69	.84	1.63	1.25	1.06	1.16	3.25	2.25	2.03	37
C5D8BH	2102012	5	2	8	19.50	4.31	8.12	.63	.69	.84	1.63	1.25	1.06	1.16	3.25	2.25	2.03	58
C5T6BH	2102020	5	3	6	17.62	6.34	6.12	.63	.69	.84	1.63	1.25	1.06	1.16	3.25	2.25	2.03	51
C5T8BH	2102022	5	3	8	19.5	6.34	8.12	.63	.69	.84	1.63	1.25	1.06	1.16	3.25	2.25	2.03	81
<b>7.5 Tons</b>																		
C7S6BH	2102050	7.5	1	6	15.00	2.28	6.12	-	-	-	1.63	1.25	1.06	1.16	3.25	1.86	-	22
C7S8BH	2102052	7.5	1	8	16.88	2.28	8.12	-	-	-	1.63	1.25	1.06	1.16	3.25	1.86	-	34
C7D6BH	2102060	7.5	2	6	17.62	4.31	6.12	.63	.69	.84	1.63	1.25	1.06	1.16	3.25	2.25	2.03	37
C7D8BH	2102062	7.5	2	8	19.50	4.31	8.12	.63	.69	.84	1.63	1.25	1.06	1.16	3.25	2.25	2.03	58
C7T6BH	2102070	7.5	3	6	17.62	6.34	6.12	.63	.69	.84	1.63	1.25	1.06	1.16	3.25	2.25	2.03	51
C7T8BH	2102072	7.5	3	8	19.5	6.34	8.12	.63	.69	.84	1.63	1.25	1.06	1.16	3.25	2.25	2.03	81
<b>10 Tons</b>																		
C10S8BH	2102100	10	1	8	18.38	2.28	8.12	-	-	-	1.88	1.38	1.31	1.69	4.00	2.08	-	39
C10S10BH	2102102	10	1	10	20.38	2.28	10.12	-	-	-	1.88	1.38	1.31	1.69	4.00	2.08	-	52
C10S12BH	2102104	10	1	12	22.25	2.28	12.12	-	-	-	1.88	1.38	1.31	1.69	4.00	2.08	-	62
C10S14BH	2102106	10	1	14	24.38	2.28	14.12	-	-	-	1.88	1.38	1.31	1.69	4.00	2.08	-	69
C10D6BH	2102110	10	2	6	18.94	4.31	6.12	.63	.69	.84	1.88	1.38	1.31	1.69	4.00	2.68	2.03	44
C10D8BH	2102112	10	2	8	20.69	4.31	8.12	.63	.69	.84	1.88	1.38	1.31	1.69	4.00	2.68	2.03	65
C10D10BH	2102114	10	2	10	22.69	4.31	10.12	.63	.69	.84	1.88	1.38	1.31	1.69	4.00	2.68	2.03	89
C10D12BH	2102116	10	2	12	24.56	4.31	12.12	.63	.69	.84	1.88	1.38	1.31	1.69	4.00	2.68	2.03	106
C10D14BH	2102118	10	2	14	26.69	4.31	14.12	.63	.69	.84	1.88	1.38	1.31	1.69	4.00	2.68	2.03	121
C10T8BH	2102120	10	3	8	20.69	6.34	8.12	.63	.69	.84	1.88	1.38	1.31	1.69	4.00	3.47	2.03	90
C10T10BH	2102122	10	3	10	22.69	6.34	10.12	.63	.69	.84	1.88	1.38	1.31	1.69	4.00	3.47	2.03	124
C10T12BH	2102124	10	3	12	24.56	6.34	12.12	.63	.69	.84	1.88	1.38	1.31	1.69	4.00	3.47	2.03	147
C10T14BH	2102126	10	3	14	26.69	6.34	14.12	.63	.69	.84	1.88	1.38	1.31	1.69	4.00	3.47	2.03	171
C10Q8BH	2102130	10	4	8	20.69	8.37	8.12	.63	.69	.84	1.88	1.38	1.31	1.69	4.00	3.62	2.03	115
C10Q10BH	2102132	10	4	10	22.69	8.37	10.12	.63	.69	.84	1.88	1.38	1.31	1.69	4.00	3.62	2.03	161
<b>15 Tons</b>																		
C15S10BH	2102170	15	1	10	23.69	3.04	10.12	-	-	-	2.62	1.88	1.56	2.12	5.50	2.81	-	86
C15S12BH	2102172	15	1	12	25.56	3.04	12.12	-	-	-	2.62	1.88	1.56	2.12	5.50	2.81	-	102
C15S14BH	2102174	15	1	14	27.56	3.04	14.12	-	-	-	2.62	1.88	1.56	2.12	5.50	2.81	-	121
C15D10BH	2102180	15	2	10	26.69	5.34	10.1	.75	.81	1.00	2.62	1.88	1.56	2.12	5.50	3.40	2.30	131
C15D12BH	2102182	15	2	12	28.56	5.34	12.12	.75	.81	1.00	2.62	1.88	1.56	2.12	5.50	3.40	2.30	154
C15D14BH	2102184	15	2	14	30.56	5.34	14.12	.75	.81	1.00	2.62	1.88	1.56	2.12	5.50	3.40	2.30	184
C15T8BH	2102190	15	3	8	24.69	7.64	8.12	.75	.81	1.00	2.62	1.88	1.56	2.12	5.50	3.88	2.30	127
C15T10BH	2102192	15	3	10	26.69	7.64	10.12	.75	.81	1.00	2.62	1.88	1.56	2.12	5.50	3.88	2.30	174
C15T12BH	2102194	15	3	12	28.56	7.64	12.12	.75	.81	1.00	2.62	1.88	1.56	2.12	5.50	3.88	2.30	204
C15T14BH	2102196	15	3	14	30.56	7.64	14.12	.75	.81	1.00	2.62	1.88	1.56	2.12	5.50	3.88	2.30	236
C15Q10BH	2102200	15	4	10	26.69	9.94	10.12	.75	.81	1.00	2.62	1.88	1.56	2.12	5.50	3.88	2.30	216
<b>20 Tons</b>																		
C20S18BH	2102244	20	1	18	32.25	4.04	18.12	-	-	-	2.5	1.88	1.69	2.12	5.50	2.80	-	215
C20D12BH	2102250	20	2	12	32.06	5.84	12.12	.88	.97	1.14	2.5	1.88	1.69	2.12	5.50	3.31	2.30	182

McKissick Blocks



680 Blocks – “H” Fitting – Blocks with Hanger – See Drawing on Page 339

Model No.	680-H Inquiry Stock No.	Working Load Limit (Tons)	No. of Sheaves	Sheave Diam. (in)	Dimensions (in)													Weight Each (lb)
					A	E	F	G	H	I	L	M	N	O	P	Q	X	
C20D14BH	2102252	20	2	14	32.88	5.84	14.12	.88	.97	1.14	2.5	1.88	1.69	2.12	5.50	3.31	2.30	214
C20D16BH	2102254	20	2	16	35.16	5.84	16.12	.88	.97	1.14	2.5	1.88	1.69	2.12	5.50	3.31	2.30	254
C20T10BH	2102260	20	3	10	29.12	8.14	10.12	.88	.97	1.14	2.5	1.88	1.69	2.12	5.50	3.88	2.30	200
C20T12BH	2102262	20	3	12	31.06	8.14	12.12	.88	.97	1.14	2.5	1.88	1.69	2.12	5.50	3.88	2.30	229
C20T14BH	2102264	20	3	14	32.88	8.14	14.12	.88	.97	1.14	2.50	1.88	1.69	2.12	5.50	3.88	2.30	275
C20T16BH	2102266	20	3	16	35.12	8.14	16.12	.88	.97	1.14	2.50	1.88	1.69	2.12	5.50	3.88	2.30	329
C20Q8BH	2102270	20	4	8	26.94	10.44	8.12	.88	.97	1.14	2.50	1.88	1.69	2.12	5.50	3.88	2.30	196
C20Q10BH	2102272	20	4	10	29.12	10.44	10.12	.88	.97	1.14	2.50	1.88	1.69	2.12	5.50	3.88	2.30	247
C20Q12BH	2102274	20	4	12	31.06	10.44	12.12	.88	.97	1.14	2.50	1.88	1.69	2.12	5.50	3.88	2.30	287
C20Q14BH	2102276	20	4	14	32.88	10.44	14.12	.88	.97	1.14	2.50	1.88	1.69	2.12	5.50	3.88	2.30	337
<b>25 Tons</b>																		
C25S18BH	2102314	25	1	18	32.25	4.04	18.12	-	-	-	2.50	1.88	1.69	2.12	5.50	2.80	-	215
C25D12BH	2102320	25	2	12	32.06	5.84	12.12	.88	.97	1.14	2.50	1.88	1.69	2.12	5.50	3.31	2.30	182
C25D14BH	2102322	25	2	14	32.88	5.84	14.12	.88	.97	1.14	2.50	1.88	1.69	2.12	5.50	3.31	2.30	214
C25D16BH	2102324	25	2	16	35.16	5.84	16.12	.88	.97	1.14	2.50	1.88	1.69	2.12	5.50	3.31	2.30	254
C25T10BH	2102330	25	3	10	29.12	8.14	10.12	.88	.97	1.14	2.50	1.88	1.69	2.12	5.50	3.88	2.30	200
C25T12BH	2102332	25	3	12	31.06	8.14	12.12	.88	.97	1.14	2.50	1.88	1.69	2.12	5.50	3.88	2.30	229
C25T14BH	2102334	25	3	14	32.88	8.14	14.12	.88	.97	1.14	2.50	1.88	1.69	2.12	5.50	3.88	2.30	275
C25T16BH	2102336	25	3	16	35.12	8.14	16.12	.88	.97	1.14	2.50	1.88	1.69	2.12	5.50	3.88	2.30	329
C25Q8BH	2102340	25	4	8	26.94	10.44	8.12	.88	.97	1.14	2.50	1.88	1.69	2.12	5.50	3.88	2.30	196
C25Q10BH	2102342	25	4	10	29.12	10.44	10.12	.88	.97	1.14	2.50	1.88	1.69	2.12	5.50	3.88	2.30	247
C25Q12BH	2102344	25	4	12	31.06	10.44	12.12	.88	.97	1.14	2.50	1.88	1.69	2.12	5.50	3.88	2.30	287
C25Q14BH	2102346	25	4	14	32.88	10.44	14.12	.88	.97	1.14	2.50	1.88	1.69	2.12	5.50	3.88	2.30	337
<b>30 Tons</b>																		
C30D12BH	2102390	30	2	12	35.38	6.84	12.12	1.00	1.06	1.34	2.75	2.50	1.69	2.25	7.00	3.83	2.80	224
C30D14BH	2102392	30	2	14	37.25	6.84	14.12	1.00	1.06	1.34	2.75	2.50	1.69	2.25	7.00	3.83	2.80	260
C30D16BH	2102394	30	2	16	39.62	6.84	16.12	1.00	1.06	1.34	2.75	2.50	1.69	2.25	7.00	3.83	2.80	302
C30D18BH	2102396	30	2	18	41.38	6.84	18.12	1.00	1.06	1.34	2.75	2.50	1.69	2.25	7.00	3.83	2.80	379
C30T10BH	2102400	30	3	10	33.50	8.14	10.12	1.00	1.06	1.34	2.75	2.50	1.69	2.25	7.00	4.25	2.30	253
C30T12BH	2102402	30	3	12	35.38	8.14	12.12	1.00	1.06	1.34	2.75	2.50	1.69	2.25	7.00	4.25	2.30	279
C30T14BH	2102404	30	3	14	37.25	8.14	14.12	1.00	1.06	1.34	2.75	2.50	1.69	2.25	7.00	4.25	2.30	322
C30T16BH	2102406	30	3	16	39.62	8.14	16.12	1.00	1.06	1.34	2.75	2.50	1.69	2.25	7.00	4.25	2.30	384
C30Q10BH	2102410	30	4	10	41.38	10.44	10.12	1.00	1.06	1.34	2.75	2.50	1.69	2.25	7.00	4.25	2.30	306
C30Q12BH	2102412	30	4	12	35.38	10.44	12.12	1.00	1.06	1.34	2.75	2.50	1.69	2.25	7.00	4.25	2.30	342
C30Q14BH	2102414	30	4	14	37.25	10.44	14.12	1.00	1.06	1.34	2.75	2.50	1.69	2.25	7.00	4.25	2.30	393
C30Q16BH	2102416	30	4	16	39.62	10.44	16.12	1.00	1.06	1.34	2.75	2.50	1.69	2.25	7.00	4.25	2.30	469
<b>35 Tons</b>																		
C35D12BH	2102450	35	2	12	35.38	6.84	12.12	1.00	1.06	1.34	2.75	2.50	1.69	2.25	7.00	3.83	2.80	224
C35D14BH	2102452	35	2	14	37.25	6.84	14.12	1.00	1.06	1.34	2.75	2.50	1.69	2.25	7.00	3.83	2.80	260
C35D16BH	2102454	35	2	16	39.62	6.84	16.12	1.00	1.06	1.34	2.75	2.50	1.69	2.25	7.00	3.83	2.80	302
C35D18BH	2102456	35	2	18	41.38	6.84	18.12	1.00	1.06	1.34	2.75	2.50	1.69	2.25	7.00	3.83	2.80	379
C35T10BH	2102460	35	3	10	33.50	8.14	10.12	1.00	1.06	1.34	2.75	2.50	1.69	2.25	7.00	4.25	2.30	253
C35T12BH	2102462	35	3	12	35.38	8.14	12.12	1.00	1.06	1.34	2.75	2.50	1.69	2.25	7.00	4.25	2.30	279
C35T14BH	2102464	35	3	14	37.25	8.14	14.12	1.00	1.06	1.34	2.75	2.50	1.69	2.25	7.00	4.25	2.30	322
C35T16BH	2102466	35	3	16	39.62	8.14	16.12	1.00	1.06	1.34	2.75	2.50	1.69	2.25	7.00	4.25	2.30	384
C35Q10BH	2102470	35	4	10	41.38	10.44	10.12	1.00	1.06	1.34	2.75	2.50	1.69	2.25	7.00	4.25	2.30	306
C35Q12BH	2102472	35	4	12	35.38	10.44	12.12	1.00	1.06	1.34	2.75	2.50	1.69	2.25	7.00	4.25	2.30	342
C35Q14BH	2102474	35	4	14	37.25	10.44	14.12	1.00	1.06	1.34	2.75	2.50	1.69	2.25	7.00	4.25	2.30	393
C35Q16BH	2102476	35	4	16	39.62	10.44	16.12	1.00	1.06	1.34	2.75	2.50	1.69	2.25	7.00	4.25	2.30	469
<b>40 Tons</b>																		
C40D18BH	2102512	40	2	18	42.88	7.84	18.12	1.13	1.25	1.46	3.00	2.88	2.06	2.75	7.25	4.19	3.30	528
C40D20BH	2102514	40	2	20	44.12	7.84	20.12	1.13	1.25	1.46	3.00	2.88	2.06	2.75	7.25	4.19	3.30	617
C40D24BH	2102516	40	2	24	48.12	7.84	24.12	1.13	1.25	1.46	3.00	2.88	2.06	2.75	7.25	4.19	3.30	796
C40T14BH	2102520	40	3	14	40.12	8.14	14.12	1.13	1.25	1.46	3.00	2.88	2.06	2.75	8.00	4.47	2.30	356
C40T16BH	2102522	40	3	16	42.38	8.14	16.12	1.13	1.25	1.46	3.00	2.88	2.06	2.75	8.00	4.47	2.30	416
C40T18BH	2102524	40	3	18	42.88	10.40	18.12	1.13	1.25	1.46	3.00	2.88	2.06	2.75	7.25	4.50	2.90	646
C40T20BH	2102526	40	3	20	44.12	10.40	20.12	1.13	1.25	1.46	3.00	2.88	2.06	2.75	7.25	4.50	2.90	756
C40Q12BH	2102530	40	4	12	38.25	10.44	12.12	1.13	1.25	1.46	3.00	2.88	2.06	2.75	8.00	5.25	2.30	388
C40Q14BH	2102532	40	4	14	40.12	10.44	14.12	1.13	1.25	1.46	3.00	2.88	2.06	2.75	8.00	5.25	2.30	432
C40Q16BH	2102534	40	4	16	42.38	10.44	16.12	1.13	1.25	1.46	3.00	2.88	2.06	2.75	8.00	5.25	2.30	501
C40Q18BH	2102536	40	4	18	42.88	13.33	18.12	1.13	1.25	1.46	3.00	2.88	2.06	2.75	7.25	4.50	2.90	766
<b>45 Tons</b>																		
C45D18BH	2102582	45	2	18	42.88	7.84	18.12	1.13	1.25	1.46	3.00	2.88	2.06	2.75	7.25	4.19	3.30	528
C45D20BH	2102584	45	2	20	44.12	7.84	20.12	1.13	1.25	1.46	3.00	2.88	2.06	2.75	7.25	4.19	3.30	617
C45D24BH	2102586	45	2	24	48.12	7.84	24.12	1.13	1.25	1.46	3.00	2.88	2.06	2.75	7.25	4.19	3.30	796
C45T14BH	2102590	45	3	14	40.12	8.14	14.12	1.13	1.25	1.46	3.00	2.88	2.06	2.75	8.00	4.47	2.30	356
C45T16BH	2102592	45	3	16	42.38	8.14	16.12	1.13	1.25	1.46	3.00	2.88	2.06	2.75	8.00	4.47	2.30	416
C45T18BH	2102594	45	3	18	42.88	10.40	18.12	1.13	1.25	1.46	3.00	2.88	2.06	2.75	7.25	4.50	2.90	646
C45T20BH	2102596	45	3	20	44.12	10.40	20.12	1.13	1.25	1.46	3.00	2.88	2.06	2.75	7.25	4.50	2.90	756
C45Q12BH	2102600	45	4	12	38.25	10.44	12.12	1.13	1.25	1.46	3.00	2.88	2.06	2.75	8.00	5.25	2.30	388
C45Q14BH	2102602	45	4	14	40.12	10.44	14.12	1.13	1.25	1.46	3.00	2.88	2.06	2.75	8.00	5.25	2.30	432

# McKissick® Construction Blocks

## 680 Blocks – “H” Fitting – Blocks with Hanger – See Drawing on Page 339

Model No.	680-H Inquiry Stock No.	Working Load Limit (Tons)	No. of Sheaves	Sheave Diam. (in)	Dimensions (in)													Weight Each (lb)
					A	E	F	G	H	I	L	M	N	O	P	Q	X	
C45Q16BH	2102604	45	4	16	42.38	10.44	16.12	1.13	1.25	1.46	3.00	2.88	2.06	2.75	8.00	5.25	2.30	501
C45Q18BH	2102606	45	4	18	42.88	13.33	18.12	1.13	1.25	1.46	3.00	2.88	2.06	2.75	7.25	4.50	2.90	766
<b>50 Tons</b>																		
C50D20BH	2102640	50	2	20	48.75	7.84	20.12	1.25	1.38	1.62	3.50	3.25	2.31	3.00	9.00	4.56	3.30	688
C50D24BH	2102642	50	2	24	52.75	7.84	24.12	1.25	1.38	1.62	3.50	3.25	2.31	3.00	9.00	4.56	3.30	871
C50T18BH	2102650	50	3	18	47.50	10.40	18.12	1.25	1.38	1.62	3.50	3.25	2.31	3.00	9.00	5.47	2.90	700
C50T20BH	2102652	50	3	20	48.75	10.40	20.12	1.25	1.38	1.62	3.50	3.25	2.31	3.00	9.00	5.47	2.90	812
C50T24BH	2102654	50	3	24	52.75	10.40	24.12	1.25	1.38	1.62	3.50	3.25	2.31	3.00	9.00	5.47	2.90	1025
C50Q16BH	2102660	50	4	16	45.38	13.33	16.12	1.25	1.38	1.62	3.50	3.25	2.31	3.00	9.00	5.88	2.90	728
C50Q18BH	2102662	50	4	18	47.50	13.33	18.12	1.25	1.38	1.62	3.50	3.25	2.31	3.00	9.00	5.88	2.90	878
<b>55 Tons</b>																		
C55D20BH	2102700	55	2	20	48.75	7.84	20.12	1.25	1.38	1.62	3.50	3.25	2.31	3.00	9.00	4.56	3.30	688
C55D24BH	2102702	55	2	24	52.75	7.84	24.12	1.25	1.38	1.62	3.50	3.25	2.31	3.00	9.00	4.56	3.30	871
C55T18BH	2102710	55	3	18	47.50	10.40	18.12	1.25	1.38	1.62	3.50	3.25	2.31	3.00	9.00	5.47	2.90	700
C55T20BH	2102712	55	3	20	48.75	10.40	20.12	1.25	1.38	1.62	3.50	3.25	2.31	3.00	9.00	5.47	2.90	812
C55T24BH	2102714	55	3	24	52.75	10.40	24.12	1.25	1.38	1.62	3.50	3.25	2.31	3.00	9.00	5.47	2.90	1025
C55Q16BH	2102720	55	4	16	45.38	13.33	16.12	1.25	1.38	1.62	3.50	3.25	2.31	3.00	9.00	5.88	2.90	728
C55Q18BH	2102722	55	4	18	47.00	13.33	18.12	1.25	1.38	1.62	3.50	3.25	2.31	3.00	9.00	5.88	2.90	878
<b>60 Tons</b>																		
C60T18BH	2102760	60	3	18	47.88	10.40	18.12	1.25	1.38	1.62	3.50	3.63	2.31	3.00	9.00	5.47	2.90	700
C60T20BH	2102762	60	3	20	49.12	10.40	20.12	1.25	1.38	1.62	3.50	3.63	2.31	3.00	9.00	5.47	2.90	812
C60T24BH	2102764	60	3	24	53.12	10.40	24.12	1.25	1.38	1.62	3.50	3.63	2.31	3.00	9.00	5.47	2.90	1025
C60Q18BH	2102770	60	4	18	47.88	13.33	18.12	1.25	1.38	1.62	3.50	3.63	2.31	3.00	9.00	5.88	2.90	878
C60Q20BH	2102772	60	4	20	49.12	13.33	20.12	1.25	1.38	1.62	3.50	3.63	2.31	3.00	9.00	5.88	2.90	1028
C60Q24BH	2102774	60	4	24	53.12	13.33	24.12	1.25	1.38	1.62	3.50	3.63	2.31	3.00	9.00	5.88	2.90	1238
<b>65 Tons</b>																		
C65T18BH	2102810	65	3	18	47.88	10.40	18.12	1.25	1.38	1.62	3.50	3.63	2.31	3.00	9.00	5.47	2.90	700
C65T20BH	2102812	65	3	20	49.12	10.40	20.12	1.25	1.38	1.62	3.50	3.63	2.31	3.00	9.00	5.47	2.90	812
C65T24BH	2102814	65	3	24	53.12	10.40	24.12	1.25	1.38	1.62	3.50	3.63	2.31	3.00	9.00	5.47	2.90	1025
C65Q18BH	2102820	65	4	18	47.88	13.33	18.12	1.25	1.38	1.62	3.50	3.63	2.31	3.00	9.00	5.88	2.90	878
C65Q20BH	2102822	65	4	20	49.12	13.33	20.12	1.25	1.38	1.62	3.50	3.63	2.31	3.00	9.00	5.88	2.90	1028
C65Q24BH	2102824	65	4	24	53.12	13.33	24.12	1.25	1.38	1.62	3.50	3.63	2.31	3.00	9.00	5.88	2.90	1238
<b>70 Tons</b>																		
C70T20BH	2102830	70	3	20	55.38	11.14	20.12	1.38	1.50	1.82	4.50	4.62	2.81	3.75	11.50	6.41	3.30	1070
C70Q20BH	2102840	70	4	20	55.38	13.31	20.12	1.38	1.50	1.82	4.50	4.62	2.81	3.75	11.50	7.23	2.90	1135
C70Q24BH	2102842	70	4	24	59.38	13.31	24.12	1.38	1.50	1.82	4.50	4.62	2.81	3.75	11.50	7.23	2.90	1460
C70QN20BH	2102850	70	5	20	55.38	18.23	20.12	1.38	1.50	1.82	4.50	4.62	2.81	3.75	11.50	6.41	3.30	1490
C70QN24BH	2102852	70	5	24	59.38	18.23	24.12	1.38	1.50	1.82	4.50	4.62	2.81	3.75	11.50	6.41	3.30	1900
<b>80 Tons</b>																		
C80T20BH	2102860	80	3	20	55.38	11.14	20.12	1.38	1.50	1.82	4.50	4.62	2.81	3.75	11.50	6.41	3.30	1070
C80Q20BH	2102870	80	4	20	55.38	13.31	20.12	1.38	1.50	1.82	4.50	4.62	2.81	3.75	11.50	7.23	2.90	1200
C80Q24BH	2102872	80	4	24	59.38	13.31	24.12	1.38	1.50	1.82	4.50	4.62	2.81	3.75	11.50	7.23	2.90	1460
C80QN20BH	2102880	80	5	20	55.38	18.23	20.12	1.38	1.50	1.82	4.50	4.62	2.81	3.75	11.50	6.41	3.30	1490
C80QN24BH	2102882	80	5	24	59.38	18.23	24.12	1.38	1.50	1.82	4.50	4.62	2.81	3.75	11.50	6.41	3.30	1900
<b>90 Tons</b>																		
C90Q20BH	2102920	90	4	20	55.38	13.81	20.12	1.38	1.50	1.82	4.00	4.62	2.81	3.75	11.50	6.93	2.90	1260
C90Q24BH	2102922	90	4	24	59.38	13.81	24.12	1.38	1.50	1.82	4.00	4.62	2.81	3.75	11.50	6.93	2.90	1620
C90QN20BH	2102930	90	5	20	55.38	18.23	20.12	1.38	1.50	1.82	4.00	4.62	2.81	3.75	11.50	6.07	3.30	1490
C90QN24BH	2102932	90	5	24	59.38	18.23	24.12	1.38	1.50	1.82	4.00	4.62	2.81	3.75	11.50	6.07	3.30	1960
<b>100 Tons</b>																		
C100QN20BH	2102970	100	5	20	55.38	18.23	20.12	1.38	1.50	1.82	4.00	4.62	2.81	3.75	11.50	6.07	3.30	1490
C100QN24BH	2102972	100	5	24	59.38	18.23	24.12	1.38	1.50	1.82	4.00	4.62	2.81	3.75	11.50	6.07	3.30	1960
C100SX20BH	2102980	100	6	20	55.38	20.41	20.12	1.38	1.50	1.82	4.00	4.62	2.81	3.75	11.50	6.93	2.90	1565
C100SX24BH	2102982	100	6	24	59.38	20.41	24.12	1.38	1.50	1.82	4.00	4.62	2.81	3.75	11.50	6.93	2.90	2055

McKissick  
Blocks

**680 BLOCKS – “S” FITTING**

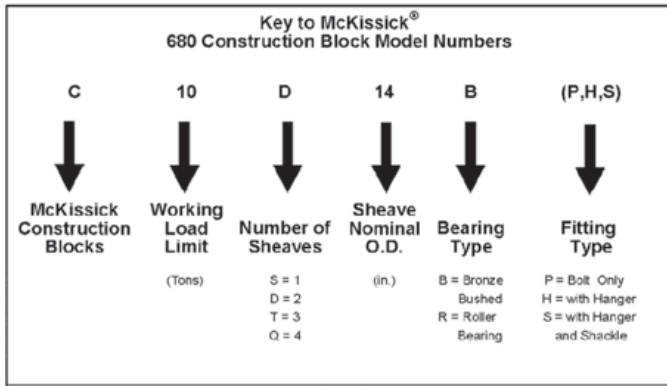

Sheave Diameter (in.)	WireLine Size (in.)									
	3/8	7/16	1/2	9/16	5/8	3/4	7/8	1	1-1/8	1-1/4
6										
8										
10										
12										
14										
16										
18										
20										
24										



All sizes are RFID EQUIPPED.

**680 Blocks – “S” Fitting – Blocks with Hanger and Shackle – See Drawing on Page 339**

Model No.	680-S Inquiry Stock No.	Working Load Limit (Tons)	No. of Sheaves	Sheave Diam. (in)	Dimensions (in)												Weight Each (lb)
					A	E	F	G	H	I	S	T	U	V	W	X	
<b>5 Tons</b>																	
C5S6BS	2103000	5	1	6	18.56	2.28	6.12	--	--	--	3.81	2.56	1.14	.88	.97	--	25
C5S8BS	2103002	5	1	8	20.44	2.28	8.12	--	--	--	3.81	2.56	1.14	.88	.97	--	37
C5D6BS	2103010	5	2	6	21.19	4.31	6.12	.63	.69	.84	3.81	2.56	1.14	.88	.97	2.03	40
C5D8BS	2103012	5	2	8	23.06	4.31	8.12	.63	.69	.84	3.81	2.56	1.14	.88	.97	2.03	61
C5T6BS	2103020	5	3	6	21.19	6.34	6.12	.63	.69	.84	3.81	2.56	1.14	.88	.97	2.03	54
C5T8BS	2103022	5	3	8	23.06	6.34	8.12	.63	.69	.84	3.81	2.56	1.14	.88	.97	2.03	84
<b>7.5 Tons</b>																	
C7S6BS	2103050	7.5	1	6	18.56	2.28	6.12	--	--	--	3.81	2.56	1.14	.88	.97	--	25
C7S8BS	2103052	7.5	1	8	20.44	2.28	8.12	--	--	--	3.81	2.56	1.14	.88	.97	--	37
C7D6BS	2103060	7.5	2	6	21.19	4.31	6.12	.63	.69	.84	3.81	2.56	1.14	.88	.97	2.03	40
C7D8BS	2103062	7.5	2	8	23.06	4.31	8.12	.63	.69	.84	3.81	2.56	1.14	.88	.97	2.03	61
C7T6BS	2103070	7.5	3	6	21.19	6.34	6.12	.63	.69	.84	3.81	2.56	1.14	.88	.97	2.03	54
C7T8BS	2103072	7.5	3	8	23.06	6.34	8.12	.63	.69	.84	3.81	2.56	1.14	.88	.97	2.03	84
<b>10 Tons</b>																	
C10S8BS	2103100	10	1	8	23.12	2.28	8.12	--	--	--	4.88	3.50	1.46	1.13	1.25	--	47
C10S10BS	2103102	10	1	10	25.12	2.28	10.12	--	--	--	4.88	3.50	1.46	1.13	1.25	--	60
C10S12BS	2103104	10	1	12	27.00	2.28	12.12	--	--	--	4.88	3.50	1.46	1.13	1.25	--	70
C10S14BS	2103106	10	1	14	29.12	2.28	14.12	--	--	--	4.88	3.50	1.46	1.13	1.25	--	77
C10D6BS	2103110	10	2	6	23.69	4.31	6.12	.63	.69	.84	4.88	3.50	1.46	1.13	1.25	2.03	52
C10D8BS	2103112	10	2	8	25.44	4.31	8.12	.63	.69	.84	4.88	3.50	1.46	1.13	1.25	2.03	73
C10D10BS	2103114	10	2	10	27.44	4.31	10.12	.63	.69	.84	4.88	3.50	1.46	1.13	1.25	2.03	97
C10D12BS	2103116	10	2	12	29.31	4.31	12.12	.63	.69	.84	4.88	3.50	1.46	1.13	1.25	2.03	114
C10D14BS	2103118	10	2	14	31.44	4.31	14.12	.63	.69	.84	4.88	3.50	1.46	1.13	1.25	2.03	129
C10T8BS	2103120	10	3	8	25.44	6.34	8.12	.63	.69	.84	4.88	3.50	1.46	1.13	1.25	2.03	98
C10T10BS	2103122	10	3	10	27.44	6.34	10.12	.63	.69	.84	4.88	3.50	1.46	1.13	1.25	2.03	132
C10T12BS	2103124	10	3	12	29.31	6.34	12.12	.63	.69	.84	4.88	3.50	1.46	1.13	1.25	2.03	155
C10T14BS	2103126	10	3	14	31.44	6.34	14.12	.63	.69	.84	4.88	3.50	1.46	1.13	1.25	2.03	179
C10Q8BS	2103130	10	4	8	25.44	8.37	8.12	.63	.69	.84	4.88	3.50	1.46	1.13	1.25	2.03	123
C10Q10BS	2103132	10	4	10	27.44	8.37	10.12	.63	.69	.84	4.88	3.50	1.46	1.13	1.25	2.03	169
<b>15 Tons</b>																	
C15S10BS	2103170	15	1	10	29.31	3.04	10.12	--	--	--	6.00	4.12	1.81	1.38	1.50	--	102
C15S12BS	2103172	15	1	12	31.19	3.04	12.12	--	--	--	6.00	4.12	1.81	1.38	1.50	--	118
C15S14BS	2103174	15	1	14	33.19	3.04	14.12	--	--	--	6.00	4.12	1.81	1.38	1.50	--	137
C15D10BS	2103180	15	2	10	32.31	5.34	10.12	.75	.81	1.00	6.00	4.12	1.81	1.38	1.50	2.30	147
C15D12BS	2103182	15	2	12	34.19	5.34	12.12	.75	.81	1.00	6.00	4.12	1.81	1.38	1.50	2.30	170
C15D14BS	2103184	15	2	14	36.19	5.34	14.12	.75	.81	1.00	6.00	4.12	1.81	1.38	1.50	2.30	200
C15T8BS	2103190	15	3	8	30.31	7.64	8.12	.75	.81	1.00	6.00	4.12	1.81	1.38	1.50	2.30	143
C15T10BS	2103192	15	3	10	32.31	7.64	10.12	.75	.81	1.00	6.00	4.12	1.81	1.38	1.50	2.30	190
C15T12BS	2103194	15	3	12	34.19	7.64	12.12	.75	.81	1.00	6.00	4.12	1.81	1.38	1.50	2.30	220
C15T14BS	2103196	15	3	14	36.19	7.64	14.12	.75	.81	1.00	6.00	4.12	1.81	1.38	1.50	2.30	252
C15Q10BS	2103200	15	4	10	32.31	9.94	10.12	.75	.81	1.00	6.00	4.12	1.81	1.38	1.5	2.30	232
<b>20 Tons</b>																	
C20S18BS	2103244	20	1	18	38.56	4.04	18.12	--	--	--	6.56	4.68	1.94	1.50	1.62	--	236
C20D12BS	2103250	20	2	12	38.38	5.84	12.12	.88	.97	1.14	6.56	4.68	1.94	1.50	1.62	2.30	203

# McKissick® Construction Blocks

## 680 Blocks –“S” Fitting – Blocks with Hanger and Shackle – See Drawing on Page 339

Model No.	680-S Inquiry Stock No.	Working Load Limit (Tons)	No. of Sheaves	Sheave Diam. (in)	Dimensions (in)													Weight Each (lb)
					A	E	F	G	H	I	S	T	U	V	W	X		
C20D14BS	2103252	20	2	14	39.19	5.84	14.12	.88	.97	1.14	6.56	4.68	1.94	1.50	1.62	2.30	235	
C20D16BS	2103254	20	2	16	41.44	5.84	16.12	.88	.97	1.14	6.56	4.68	1.94	1.50	1.62	2.30	275	
C20T10BS	2103260	20	3	10	35.44	8.14	10.12	.88	.97	1.14	6.56	4.68	1.94	1.50	1.62	2.30	221	
C20T12BS	2103262	20	3	12	37.38	8.14	12.12	.88	.97	1.14	6.56	4.68	1.94	1.50	1.62	2.30	250	
C20T14BS	2103264	20	3	14	39.19	8.14	14.12	.88	.97	1.14	6.56	4.68	1.94	1.50	1.62	2.30	296	
C20T16BS	2103266	20	3	16	41.44	8.14	16.12	.88	.97	1.14	6.56	4.68	1.94	1.50	1.62	2.30	350	
C20Q8BS	2103270	20	4	8	33.25	10.44	8.12	.88	.97	1.14	6.56	4.68	1.94	1.50	1.62	2.30	217	
C20Q10BS	2103272	20	4	10	35.44	10.44	10.12	.88	.97	1.14	6.56	4.68	1.94	1.50	1.62	2.30	268	
C20Q12BS	2103274	20	4	12	37.38	10.44	12.12	.88	.97	1.14	6.56	4.68	1.94	1.50	1.62	2.30	308	
C20Q14BS	2103276	20	4	14	39.19	10.44	14.12	.88	.97	1.14	6.56	4.68	1.94	1.50	1.62	2.30	358	
<b>25 Tons</b>																		
C25S18BS	2103314	25	1	18	38.56	4.04	18.12	--	--	--	6.56	4.68	1.94	1.50	1.62	--	236	
C25D12BS	2103320	25	2	12	38.38	5.84	12.12	.88	.97	1.14	6.56	4.68	1.94	1.50	1.62	2.30	203	
C25D14BS	2103322	25	2	14	39.19	5.84	14.12	.88	.97	1.14	6.56	4.68	1.94	1.50	1.62	2.30	235	
C25D16BS	2103324	25	2	16	41.44	5.84	16.12	.88	.97	1.14	6.56	4.68	1.94	1.50	1.62	2.30	275	
C25T10BS	2103330	25	3	10	35.44	8.14	10.12	.88	.97	1.14	6.56	4.68	1.94	1.50	1.62	2.30	221	
C25T12BS	2103332	25	3	12	37.38	8.14	12.12	.88	.97	1.14	6.56	4.68	1.94	1.50	1.62	2.30	250	
C25T14BS	2103334	25	3	14	39.19	8.14	14.12	.88	.97	1.14	6.56	4.68	1.94	1.50	1.62	2.30	296	
C25T16BS	2103336	25	3	16	41.44	8.14	16.12	.88	.97	1.14	6.56	4.68	1.94	1.50	1.62	2.30	350	
C25Q8BS	2103340	25	4	8	33.25	10.44	8.12	.88	.97	1.14	6.56	4.68	1.94	1.50	1.62	2.30	217	
C25Q10BS	2103342	25	4	10	35.44	10.44	10.12	.88	.97	1.14	6.56	4.68	1.94	1.50	1.62	2.30	268	
C25Q12BS	2103344	25	4	12	37.38	10.44	12.12	.88	.97	1.14	6.56	4.68	1.94	1.50	1.62	2.30	308	
C25Q14BS	2103346	25	4	14	39.19	10.44	14.12	.88	.97	1.14	6.56	4.68	1.94	1.50	1.62	2.30	358	
<b>30 Tons</b>																		
C30D12BS	2103390	30	2	12	41.06	6.84	12.12	1.00	1.06	1.34	6.56	4.06	1.94	1.50	1.62	2.80	245	
C30D14BS	2103392	30	2	14	42.94	6.84	14.12	1.00	1.06	1.34	6.56	4.06	1.94	1.50	1.62	2.80	281	
C30D16BS	2103394	30	2	16	45.31	6.84	16.12	1.00	1.06	1.34	6.56	4.06	1.94	1.50	1.62	2.80	323	
C30D18BS	2103396	30	2	18	47.06	6.84	18.12	1.00	1.06	1.34	6.56	4.06	1.94	1.50	1.62	2.80	400	
C30T10BS	2103400	30	3	10	39.19	8.14	10.12	1.00	1.06	1.34	6.56	4.06	1.94	1.50	1.62	2.80	274	
C30T12BS	2103402	30	3	12	41.06	8.14	12.12	1.00	1.06	1.34	6.56	4.06	1.94	1.50	1.62	2.80	300	
C30T14BS	2103404	30	3	14	42.94	8.14	14.12	1.00	1.06	1.34	6.56	4.06	1.94	1.50	1.62	2.80	343	
C30T16BS	2103406	30	3	16	45.6	8.14	16.12	1.00	1.06	1.34	6.56	4.06	1.94	1.50	1.62	2.80	405	
C30Q10BS	2103410	30	4	10	47.06	10.44	10.12	1.00	1.06	1.34	6.56	4.06	1.94	1.50	1.62	2.80	327	
C30Q12BS	2103412	30	4	12	41.06	10.44	12.12	1.00	1.06	1.34	6.56	4.06	1.94	1.50	1.62	2.80	363	
C30Q14BS	2103414	30	4	14	42.94	10.44	14.12	1.00	1.06	1.34	6.56	4.06	1.94	1.50	1.62	2.80	414	
C30Q16BS	2103416	30	4	16	45.31	10.44	16.12	1.00	1.06	1.34	6.56	4.06	1.94	1.50	1.62	2.80	390	
<b>35 Tons</b>																		
C35D12BS	2103450	35	2	12	41.06	6.84	12.12	1.00	1.06	1.34	6.56	4.06	1.94	1.50	1.62	2.80	245	
C35D14BS	2103452	35	2	14	42.94	6.84	14.12	1.00	1.06	1.34	6.56	4.06	1.94	1.50	1.62	2.80	281	
C35D16BS	2103454	35	2	16	45.31	6.84	16.12	1.00	1.06	1.34	6.56	4.06	1.94	1.50	1.62	2.80	323	
C35D18BS	2103456	35	2	18	47.06	6.84	18.12	1.00	1.06	1.34	6.56	4.06	1.94	1.50	1.62	2.80	400	
C35T10BS	2103460	35	3	10	39.19	8.14	10.12	1.00	1.06	1.34	6.56	4.06	1.94	1.50	1.62	2.80	274	
C35T12BS	2103462	35	3	12	41.06	8.14	12.12	1.00	1.06	1.34	6.56	4.06	1.94	1.50	1.62	2.80	300	
C35T14BS	2103464	35	3	14	42.94	8.14	14.12	1.00	1.06	1.34	6.56	4.06	1.94	1.50	1.62	2.30	343	
C35T16BS	2103466	35	3	16	45.31	8.14	16.12	1.00	1.06	1.34	6.56	4.06	1.94	1.50	1.62	2.30	405	
C35Q10BS	2103470	35	4	10	47.06	10.44	10.12	1.00	1.06	1.34	6.56	4.06	1.94	1.50	1.62	2.30	327	
C35Q12BS	2103472	35	4	12	41.06	10.44	12.12	1.00	1.06	1.34	6.56	4.06	1.94	1.50	1.62	2.30	363	
C35Q14BS	2103474	35	4	14	42.94	10.44	14.12	1.00	1.06	1.34	6.56	4.06	1.94	1.50	1.62	2.30	414	
C35Q16BS	2103476	35	4	16	45.31	10.44	16.12	1.00	1.06	1.34	6.56	4.06	1.94	1.50	1.62	2.30	490	
<b>40 Tons</b>																		
C40D18BS	2103512	40	2	18	50.25	7.84	18.12	1.13	1.25	1.46	8.00	5.12	2.50	1.75	2.25	3.30	562	
C40D20BS	2103514	40	2	20	51.50	7.84	20.12	1.13	1.25	1.46	8.00	5.12	2.50	1.75	2.25	3.30	651	
C40D24BS	2103516	40	2	24	55.50	7.84	24.12	1.13	1.25	1.46	8.00	5.12	2.50	1.75	2.25	3.30	830	
C40T14BS	2103520	40	3	14	47.50	8.14	14.12	1.13	1.25	1.46	8.00	5.12	2.50	1.75	2.25	2.30	390	
C40T16BS	2103522	40	3	16	49.75	8.14	16.12	1.13	1.25	1.46	8.00	5.12	2.50	1.75	2.25	2.30	450	
C40T18BS	2103524	40	3	18	50.25	10.40	18.12	1.13	1.25	1.46	8.00	5.12	2.50	1.75	2.25	2.90	680	
C40T20BS	2103526	40	3	20	51.50	10.40	20.12	1.13	1.25	1.46	8.00	5.12	2.50	1.75	2.25	2.90	790	
C40Q12BS	2103530	40	4	12	45.62	10.44	12.12	1.13	1.25	1.46	8.00	5.12	2.50	1.75	2.25	2.30	422	
C40Q14BS	2103532	40	4	14	47.50	10.44	14.12	1.13	1.25	1.46	8.00	5.12	2.50	1.75	2.25	2.30	466	
C40Q16BS	2103534	40	4	16	49.75	10.44	16.12	1.13	1.25	1.46	8.00	5.12	2.50	1.75	2.25	2.30	535	
C40Q18BS	2103536	40	4	18	50.25	13.33	18.12	1.13	1.25	1.46	8.00	5.12	2.50	1.75	2.25	2.90	800	
<b>45 Tons</b>																		
C45D18BS	2103582	45	2	18	50.25	7.84	18.12	1.13	1.25	1.46	8.00	5.12	2.50	1.75	2.25	3.30	562	
C45D20BS	2103584	45	2	20	51.50	7.84	20.12	1.13	1.25	1.46	8.00	5.12	2.50	1.75	2.25	3.30	651	
C45D24BS	2103586	45	2	24	55.50	7.84	24.12	1.13	1.25	1.46	8.00	5.12	2.50	1.75	2.25	3.30	830	
C45T14BS	2103590	45	3	14	47.50	8.14	14.12	1.13	1.25	1.46	8.00	5.12	2.50	1.75	2.25	2.30	390	
C45T16BS	2103592	45	3	16	49.75	8.14	16.12	1.13	1.25	1.46	8.00	5.12	2.50	1.75	2.25	2.30	450	
C45T18BS	2103594	45	3	18	50.25	10.40	18.12	1.13	1.25	1.46	8.00	5.12	2.50	1.75	2.25	2.90	680	
C45T20BS	2103596	45	3	20	51.50	10.40	20.12	1.13	1.25	1.46	8.00	5.12	2.50	1.75	2.25	2.90	790	
C45Q12BS	2103600	45	4	12	45.62	10.44	12.12	1.13	1.25	1.46	8.00	5.12	2.50	1.75	2.25	2.30	422	
C45Q14BS	2103602	45	4	14	47.50	10.44	14.12	1.13	1.25	1.46	8.00	5.12	2.50	1.75	2.25	2.30	466	

McKissick Blocks



680 Blocks – “S” Fitting – Blocks with Hanger and Shackle – See Drawing on Page 339

Model No.	680-S Inquiry Stock No.	Working Load Limit (Tons)	No. of Sheaves	Sheave Diam. (in)	Dimensions (in)												Weight Each (lb)
					A	E	F	G	H	I	S	T	U	V	W	X	
C45Q16BS	2103604	45	4	16	49.75	10.44	16.12	1.13	1.25	1.46	8.00	5.12	2.50	1.75	2.25	2.30	535
C45Q18BS	2103606	45	4	18	50.25	13.33	18.12	1.13	1.25	1.46	8.00	5.12	2.50	1.75	2.25	2.90	800
<b>50 Tons</b>																	
C50D20BS	2103640	50	2	20	56.81	7.84	20.12	1.25	1.38	1.62	8.88	5.63	2.88	2.00	2.40	3.30	740
C50D24BS	2103642	50	2	24	60.81	7.84	24.12	1.25	1.38	1.62	8.88	5.63	2.88	2.00	2.40	3.30	923
C50T18BS	2103650	50	3	18	55.56	10.40	18.12	1.25	1.38	1.62	8.88	5.25	2.88	2.00	2.40	2.90	752
C50T20BS	2103652	50	3	20	56.81	10.40	20.12	1.25	1.38	1.62	8.88	5.25	2.88	2.00	2.40	2.90	864
C50T24BS	2103654	50	3	24	60.81	10.40	24.12	1.25	1.38	1.62	8.88	5.25	2.88	2.00	2.40	2.90	1077
C50Q16BS	2103660	50	4	16	53.44	13.33	16.12	1.25	1.38	1.62	8.88	5.25	2.88	2.00	2.40	2.90	780
C50Q18BS	2103662	50	4	18	55.56	13.33	18.12	1.25	1.38	1.62	8.88	5.25	2.88	2.00	2.40	2.90	930
<b>55 Tons</b>																	
C55D20BS	2103700	55	2	20	56.81	7.84	20.12	1.25	1.38	1.62	8.88	5.63	2.88	2.00	2.40	3.30	740
C55D24BS	2103702	55	2	24	60.81	7.84	24.12	1.25	1.38	1.62	8.88	5.63	2.88	2.00	2.40	3.30	923
C55T18BS	2103710	55	3	18	55.56	10.40	18.12	1.25	1.38	1.62	8.88	5.25	2.88	2.00	2.40	2.90	752
C55T20BS	2103712	55	3	20	56.81	10.40	20.12	1.25	1.38	1.62	8.88	5.25	2.88	2.00	2.40	2.90	864
C55T24BS	2103714	55	3	24	60.81	10.40	24.12	1.25	1.38	1.62	8.88	5.25	2.88	2.00	2.40	2.90	1077
C55Q16BS	2103720	55	4	16	53.44	13.33	16.12	1.25	1.38	1.62	8.88	5.25	2.88	2.00	2.40	2.90	780
C55Q18BS	2103722	55	4	18	55.56	13.33	18.12	1.25	1.38	1.62	8.88	5.25	2.88	2.00	2.40	2.90	930
<b>60 Tons</b>																	
C60T18BS	2103760	60	3	18	55.56	10.40	18.12	1.25	1.38	1.62	8.88	5.25	2.88	2.00	2.40	2.90	752
C60T20BS	2103762	60	3	20	56.75	10.40	20.12	1.25	1.38	1.62	8.88	5.25	2.88	2.00	2.40	2.90	864
C60T24BS	2103764	60	3	24	60.75	10.40	24.12	1.25	1.38	1.62	8.88	5.25	2.88	2.00	2.40	2.90	1077
C60Q18BS	2103770	60	4	18	55.56	13.33	18.12	1.25	1.38	1.62	8.88	5.25	2.88	2.00	2.40	2.90	930
C60Q20BS	2103772	60	4	20	56.75	13.33	20.12	1.25	1.38	1.62	8.88	5.25	2.88	2.00	2.40	2.90	1080
C60Q24BS	2103774	60	4	24	60.75	13.33	24.12	1.25	1.38	1.62	8.88	5.25	2.88	2.00	2.40	2.90	1290
<b>65 Tons</b>																	
C65T18BS	2103810	65	3	18	55.56	10.40	18.12	1.25	1.38	1.62	8.88	5.25	2.88	2.00	2.40	2.90	752
C65T20BS	2103812	65	3	20	56.75	10.40	20.12	1.25	1.38	1.62	8.88	5.25	2.88	2.00	2.40	2.90	864
C65T24BS	2103814	65	3	24	60.75	10.40	24.12	1.25	1.38	1.62	8.88	5.25	2.88	2.00	2.40	2.90	1077
C65Q18BS	2103820	65	4	18	55.56	13.33	18.12	1.25	1.38	1.62	8.88	5.25	2.88	2.00	2.40	2.90	930
C65Q20BS	2103822	65	4	20	56.75	13.33	20.12	1.25	1.38	1.62	8.88	5.25	2.88	2.00	2.40	2.90	1080
C65Q24BS	2103824	65	4	24	60.75	13.33	24.12	1.25	1.38	1.62	8.88	5.25	2.88	2.00	2.40	2.90	1290
<b>70 Tons</b>																	
C70T20BS	2103830	70	3	20	65.75	11.14	20.12	1.38	1.50	1.82	11.88	7.25	3.62	2.71	3.12	3.30	1170
C70Q20BS	2103840	70	4	20	65.75	13.31	20.12	1.38	1.50	1.82	11.88	7.25	3.62	2.71	3.12	2.90	1235
C70Q24BS	2103842	70	4	24	69.75	13.31	24.12	1.38	1.50	1.82	11.88	7.25	3.62	2.71	3.12	2.90	1560
C70QN20BS	2103850	70	5	20	65.75	18.23	20.12	1.38	1.50	1.82	11.88	7.25	3.62	2.71	3.12	3.30	1590
C70QN24BS	2103852	70	5	24	69.75	18.23	24.12	1.38	1.50	1.82	11.88	7.25	3.62	2.71	3.12	3.30	2000
<b>80 Tons</b>																	
C80T20BS	2103860	80	3	20	65.75	11.14	20.12	1.38	1.50	1.82	11.88	7.25	3.62	2.71	3.12	3.30	1170
C80Q20BS	2103870	80	4	20	65.75	13.31	20.12	1.38	1.50	1.82	11.88	7.25	3.62	2.71	3.12	2.90	1300
C80Q24BS	2103872	80	4	24	69.75	13.31	24.12	1.38	1.50	1.82	11.88	7.25	3.62	2.71	3.12	2.90	1560
C80QN20BS	2103880	80	5	20	65.75	18.23	20.12	1.38	1.50	1.82	11.88	7.25	3.62	2.71	3.12	3.30	1590
C80QN24BS	2103882	80	5	24	69.75	18.23	24.12	1.38	1.50	1.82	11.88	7.25	3.62	2.71	3.12	3.30	2000
<b>90 Tons</b>																	
C90Q20BS	2103920	90	4	20	65.75	13.81	20.12	1.38	1.50	1.82	11.88	7.25	3.62	2.71	3.12	2.90	1360
C90Q24BS	2103922	90	4	24	69.75	13.81	24.12	1.38	1.50	1.82	11.88	7.25	3.62	2.71	3.12	2.90	1720
C90QN20BS	2103930	90	5	20	65.75	18.23	20.12	1.38	1.50	1.82	11.88	7.25	3.62	2.71	3.12	3.30	1590
C90QN24BS	2103932	90	5	24	69.75	18.23	24.12	1.38	1.50	1.82	11.88	7.25	3.62	2.71	3.12	3.30	2060
<b>100 Tons</b>																	
C100QN20BS	2103970	100	5	20	65.75	18.23	20.12	1.38	1.50	1.82	11.88	7.25	3.62	2.71	3.12	3.30	1590
C100QN24BS	2103972	100	5	24	69.75	18.23	24.12	1.38	1.50	1.82	11.88	7.25	3.62	2.71	3.12	3.30	2060
C100SX20BS	2103980	100	6	20	65.75	20.41	20.12	1.38	1.50	1.82	11.88	7.25	3.62	2.71	3.12	2.90	1665
C100SX24BS	2103982	100	6	24	69.75	20.41	24.12	1.38	1.50	1.82	11.88	7.25	3.62	2.71	3.12	2.90	2155

# QUIC-KIT®

## The McKissick QUIC-KIT®

### Featuring the McKissick® 750 Bridge Crane Block

The patented McKissick QUIC-KIT® system is a revolutionary concept that provides you the ability to build a factory quality replacement bridge crane block where you need it, when you need it.

The QUIC-KIT® system provides the components needed to build up to 32 possible combinations of a 750 bridge crane block; all in one kit that can be easily assembled on site.

#### Features of the McKissick QUIC-KIT® include:

- **Reduced downtime** — A replacement block can be assembled in minutes from kit components utilizing tools and assembly instructions provided in each kit.
- **Multiple versions of two sheave blocks** — Up to 32 possible block combinations are included in the 752 series block kit. Each kit contains three WireLine sizes and two center pins with multiple sheave spacers.
- **Adjustable sheave spacing in 1/2" increments** — Center pin design gives you the ability to assemble the replacement block to meet your spacing requirement.
- **The McKissick QUIC-KIT®** — Comes complete in a durable carrying case for easy transport and for storing components on the work site or warehouse.

Crosby has established a call center to answer questions concerning the QUIC-KIT®, 750 series blocks or other McKissick® blocks. To reach the call center, simply call the Block Hotline number, (800) 727-1555.



WLL (t)	752K Stock No.	Sheave O.D. (in)	Pitch Diameter		Sheave Wire	
			(in)	(mm)	(in)	(mm)
3	1003542	6.5	5.95	155	1/4, 5/16, 3/8	6.5, 8, 9-10
5	1003551	8	7.38	187	1/4, 5/16, 3/8, 7/16, 1/2	6.5, 8, 9-10, 11, 12-13
7.5	1003560	10	9.25	235	3/8, 7/16, 1/2, 9/16, 5/8	9-10, 11, 12-13, 14, 16
10	1003579	12	11.00	279	1/2, 9/16, 5/8, 3/4	12, 13, 14, 16, 19
15	1003588	14	12.50	318	5/8, 3/4, 7/8, 1	16, 19, 22, 25-26

WLL (t)	752K Stock No.	Sheave O.D. (in)	Sheave Spacing Centerline		Pitch Diameter		Sheave Wire	
			(in)	(mm)	(in)	(mm)	(in)	(mm)
3	1003595	6.5	3.25 - 5	82.6 - 127	5.95	150 - 152	1/4, 5/16, 3/8	6.5, 8, 9-10
5	1003604	8	4.5 - 6.5	114 - 165	7.38	183 - 191	1/4, 5/16, 3/8, 7/16, 1/2	6.5, 8, 9-10, 11, 12-13
7.5	1003613	10	5.25 - 7.75	133 - 203	9.25	228 - 236	3/8, 7/16, 1/2, 9/16, 5/8	9-10, 11, 12-13, 14, 16
10	1003622	12	6.5 - 10	165 - 254	11	273 - 282	1/2, 9/16, 5/8, 3/4	12-13, 14, 16, 19
15	1003631	12	7.5 - 11	191 - 279	11	273 - 282	1/2, 9/16, 5/8, 3/4	12-13, 14, 16, 19



## McKissick® Overhead Bridge Crane Blocks

- Wide range of products available (see tables below).
- Removable housing allows block to be reeved without complete disassembly.
- Bearing life and Design Factors meet:
  - ASME HST-4, Class H
  - CMAA 70 Class D
  - FEM9.511 Class 2m
  - ISO 4301.1 Class M5
- Adjustable sheave spacing in 1/2" increments (1/4" on 6-1/2" size).
- Sheave pitch diameter minimum of 16 times rope diameter on standard sizes.
- All single point shank hooks are genuine Crosby®, forged alloy steel, Quenched and Tempered, contain the patented **QUIC-CHECK®** markings and come with a world class latch that integrates with hook tip.
- **U.S. Patent 7,255,330**
- All sizes are **RFID EQUIPPED**.
- Sheave bearings are maintenance free and sealed for life (10,000 hrs.).
- Ability to attach optional anti two-block device.
- Available with shackle as lower connection point.
- Ultimate load is 5 times the Working Load Limit.

Key to McKissick® Easy-Lift® Overhead Bridge Crane Blocks					
Single and Double Sheave Blocks				Double Sheave Blocks Only	
<b>BC</b>	<b>05</b>	<b>D</b>	<b>08</b>	<b>B</b>	<b>36</b>
↓	↓	↓	↓	↓	↓
McKissick® 750 Series Bridge Crane Blocks	Working Load Limit (t)	Number of Sheaves S = 1 D = 2	Sheave Diameter (in)	Center Pin Designation	Sheave Spacing in 1/8" Increments



**BC-751**  
Single  
Sheave

### BC-751 Single Sheave

Model 751 – Single Sheave										
WLL (t)	2		3	5	7.5	10				
Sheave O.D.	6.5"	165mm	8"	203mm	10"	254mm	12"	305mm	14"	356mm
Pitch Diameter	5.69"	151mm	7.38"	187mm	9.25"	235mm	11"	279mm	12.5"	318mm
Wireline*										
1/4"	6.5mm									
5/16"	8mm									
3/8"	9 - 10mm									
7/16"	11mm									
1/2"	12 - 13mm									
9/16"	14mm									
5/8"	16mm									
3/4"	19mm									
7/8"	22mm									
1"	25 - 26mm									

\* Additional Wireline sizes available.

### BC-752 Double Sheave

Model 752 – Double Sheave						
WLL (t)	3	5	7.5	10	15	
Sheave O.D. (mm)	6.5" 165mm	8" 203mm	10" 254mm	12" 305mm	14" 356mm	
Sheave Spacing Centerline (mm)	3.25" - 5" 82.6 - 127mm	4.5" - 6.5" 114 - 165mm	5.25" - 7.75" 133 - 203mm	6.5" - 10" 165 - 254mm	7.5" - 11" 191 - 279mm	
Pitch Diameter (mm)	5.95" 150 - 152mm	7.38" 183 - 191mm	9.25" 228 - 236mm	11" 273 - 282mm	11" 273 - 282mm	
Wireline*						
1/4"	6.5mm					
5/16"	8mm					
3/8"	9 - 10mm					
7/16"	11mm					
1/2"	12 - 13mm					
9/16"	14mm					
5/8"	16mm					
3/4"	19mm					

\* Additional Wireline sizes available.

= Primary Wireline Size

= Other Wireline Sizes



**BC-752**  
Double Sheave

# McKissick® Overhead Bridge Crane Blocks

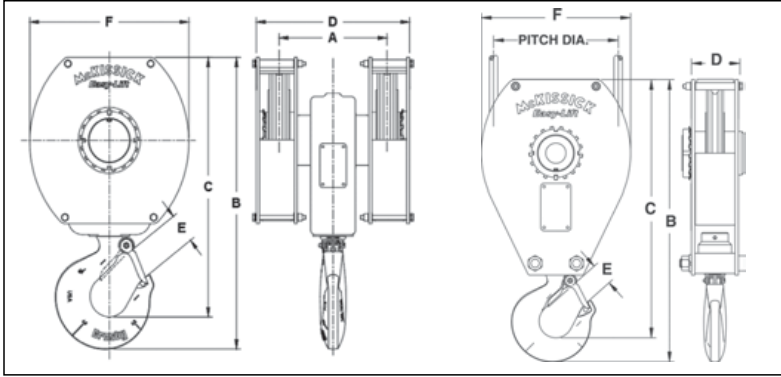

All sizes are RFID EQUIPPED.

## 751 Series Bridge Crane Blocks

Model No.	BC-751 Stock No.	Working Load Limit (t)*	Sheave Diameter (in)	Dimensions (in)					Standard Wireline Size (in)	Weight Each (lb)
				B	C	D	E	F		
<b>2 Metric Tons</b>										
BC02S06	2022539	2	6.5	13.93	12.80	2.12	1.16	7.44	1/4	18
BC02S06	2022540	2	6.5	13.93	12.80	2.12	1.16	7.44	5/16	18
BC02S06	2022541	2	6.5	13.93	12.80	2.12	1.16	7.44	3/8	18
<b>3 Metric Tons</b>										
BC03S08	2022521	3	8	16.88	15.41	2.75	1.36	8.94	1/4	35
BC03S08	2022522	3	8	16.88	15.41	2.75	1.36	8.94	5/16	35
BC03S08	2022523	3	8	16.88	15.41	2.75	1.36	8.94	3/8	35
BC03S08	2022524	3	8	16.88	15.41	2.75	1.36	8.94	7/16	35
BC03S08	2022525	3	8	16.88	15.41	2.75	1.36	8.94	1/2	35
<b>5 Metric Tons</b>										
BC05S10	2022526	5	10	21.00	19.19	3.50	1.61	11.12	3/8	60
BC05S10	2022527	5	10	21.00	19.19	3.50	1.61	11.12	7/16	60
BC05S10	2022528	5	10	21.00	19.19	3.50	1.61	11.12	1/2	60
BC05S10	2022529	5	10	21.00	19.19	3.50	1.61	11.12	9/16	60
BC05S10	2022530	5	10	21.00	19.19	3.50	1.61	11.12	5/8	60
<b>7.5 Metric Tons</b>										
BC07S12	2022531	7.5	12	25.44	23.19	4.25	2.08	13.44	1/2	115
BC07S12	2022532	7.5	12	25.44	23.19	4.25	2.08	13.44	9/16	115
BC07S12	2022533	7.5	12	25.44	23.19	4.25	2.08	13.44	5/8	115
BC07S12	2022534	7.5	12	25.44	23.19	4.25	2.08	13.44	3/4	115
<b>10 Metric Tons</b>										
BC10S14	2022535	10	14	29.12	26.50	5.00	2.27	15.50	5/8	155
BC10S14	2022536	10	14	29.12	26.50	5.00	2.27	15.50	3/4	155
BC10S14	2022537	10	14	29.12	26.50	5.00	2.27	15.50	7/8	155
BC10S14	2022538	10	14	29.12	26.50	5.00	2.27	15.50	1	155

\* Ultimate Load is 5 times the Working Load Limit.

## 752 Series Bridge Crane Blocks

Model No.	BC-752 Stock No.	Working Load Limit (t)*	Sheave Diameter (in)	Dimensions (in)						Standard Wireline Size (in)	Weight Each (lb)
				A	B	C	D	E	F		
<b>3 Metric Tons</b>											
BC03D06M26	2022731	3	6.5	3.25	13.41	11.97	5.75	1.36	7.44	1/4	37
BC03D06M26	2022739	3	6.5	3.25	13.41	11.97	5.75	1.36	7.44	5/16	37
BC03D06M26	2022747	3	6.5	3.25	13.41	11.97	5.75	1.36	7.44	3/8	37
BC03D06M28	2022732	3	6.5	3.50	13.41	11.97	5.75	1.36	7.44	1/4	37
BC03D06M28	2022740	3	6.5	3.50	13.41	11.97	5.75	1.36	7.44	5/16	37
BC03D06M28	2022748	3	6.5	3.50	13.41	11.97	5.75	1.36	7.44	3/8	37
BC03D06M30	2022733	3	6.5	3.75	13.41	11.97	5.75	1.36	7.44	1/4	37
BC03D06M30	2022741	3	6.5	3.75	13.41	11.97	5.75	1.36	7.44	5/16	37
BC03D06M30	2022749	3	6.5	3.75	13.41	11.97	5.75	1.36	7.44	3/8	37
BC03D06M32	2022734	3	6.5	4.00	13.41	11.97	5.75	1.36	7.44	1/4	37
BC03D06M32	2022742	3	6.5	4.00	13.41	11.97	5.75	1.36	7.44	5/16	37
BC03D06M32	2022750	3	6.5	4.00	13.41	11.97	5.75	1.36	7.44	3/8	37
BC03D06N34	2022735	3	6.5	4.25	13.41	11.97	6.75	1.36	7.44	1/4	37
BC03D06N34	2022743	3	6.5	4.25	13.41	11.97	6.75	1.36	7.44	5/16	37
BC03D06N34	2022751	3	6.5	4.25	13.41	11.97	6.75	1.36	7.44	3/8	37
BC03D06N36	2022736	3	6.5	4.50	13.41	11.97	6.75	1.36	7.44	1/4	37
BC03D06N36	2022744	3	6.5	4.50	13.41	11.97	6.75	1.36	7.44	5/16	37
BC03D06N36	2022752	3	6.5	4.50	13.41	11.97	6.75	1.36	7.44	3/8	37
BC03D06N38	2022737	3	6.5	4.75	13.41	11.97	6.75	1.36	7.44	1/4	37
BC03D06N38	2022745	3	6.5	4.75	13.41	11.97	6.75	1.36	7.44	5/16	37
BC03D06N38	2022753	3	6.5	4.75	13.41	11.97	6.75	1.36	7.44	3/8	37
BC03D06N40	2022738	3	6.5	5.00	13.41	11.97	6.75	1.36	7.44	1/4	37
BC03D06N40	2022746	3	6.5	5.00	13.41	11.97	6.75	1.36	7.44	5/16	37
BC03D06N40	2022754	3	6.5	5.00	13.41	11.97	6.75	1.36	7.44	3/8	37



# McKissick® Overhead Bridge Crane Blocks

## 752 Series Bridge Crane Blocks

Model No.	BC-752 Stock No.	Working Load Limit (t)*	Sheave Diameter (in)	Dimensions (in)						Standard Wireline Size (in)	Weight Each (lb)
				A	B	C	D	E	F		
<b>5 Metric Tons</b>											
BC05D08B36	2022550	5	8	4.50	16.41	14.59	7.69	1.61	8.94	1/4	75
BC05D08B36	2022551	5	8	4.50	16.41	14.59	7.69	1.61	8.94	5/16	75
BC05D08B36	2022552	5	8	4.50	16.41	14.59	7.69	1.61	8.94	3/8	75
BC05D08B36	2022553	5	8	4.50	16.41	14.59	7.69	1.61	8.94	7/16	75
BC05D08B36	2022554	5	8	4.50	16.41	14.59	7.69	1.61	8.94	1/2	75
BC05D08B40	2022555	5	8	5.00	16.41	14.59	7.69	1.61	8.94	1/4	75
BC05D08B40	2022556	5	8	5.00	16.41	14.59	7.69	1.61	8.94	5/16	75
BC05D08B40	2022557	5	8	5.00	16.41	14.59	7.69	1.61	8.94	3/8	75
BC05D08B40	2022558	5	8	5.00	16.41	14.59	7.69	1.61	8.94	7/16	75
BC05D08B40	2022559	5	8	5.00	16.41	14.59	7.69	1.61	8.94	1/2	75
BC05D08B44	2022560	5	8	5.50	16.41	14.59	7.69	1.61	8.94	1/4	75
BC05D08B44	2022561	5	8	5.50	16.41	14.59	7.69	1.61	8.94	5/16	75
BC05D08B44	2022562	5	8	5.50	16.41	14.59	7.69	1.61	8.94	3/8	75
BC05D08B44	2022563	5	8	5.50	16.41	14.59	7.69	1.61	8.94	7/16	75
BC05D08B44	2022564	5	8	5.50	16.41	14.59	7.69	1.61	8.94	1/2	75
BC05D08C44	2022565	5	8	5.50	16.41	14.59	8.69	1.61	8.94	1/4	75
BC05D08C44	2022566	5	8	5.50	16.41	14.59	8.69	1.61	8.94	5/16	75
BC05D08C44	2022567	5	8	5.50	16.41	14.59	8.69	1.61	8.94	3/8	75
BC05D08C44	2022568	5	8	5.50	16.41	14.59	8.69	1.61	8.94	7/16	75
BC05D08C44	2022569	5	8	5.50	16.41	14.59	8.69	1.61	8.94	1/2	75
BC05D08C48	2022570	5	8	6.00	16.41	14.59	8.69	1.61	8.94	1/4	75
BC05D08C48	2022571	5	8	6.00	16.41	14.59	8.69	1.61	8.94	5/16	75
BC05D08C48	2022572	5	8	6.00	16.41	14.59	8.69	1.61	8.94	3/8	75
BC05D08C48	2022573	5	8	6.00	16.41	14.59	8.69	1.61	8.94	7/16	75
BC05D08C48	2022574	5	8	6.00	16.41	14.59	8.69	1.61	8.94	1/2	75
BC05D08C52	2022575	5	8	6.50	16.41	14.59	8.69	1.61	8.94	1/4	75
BC05D08C52	2022576	5	8	6.50	16.41	14.59	8.69	1.61	8.94	5/16	75
BC05D08C52	2022577	5	8	6.50	16.41	14.59	8.69	1.61	8.94	3/8	75
BC05D08C52	2022578	5	8	6.50	16.41	14.59	8.69	1.61	8.94	7/16	75
BC05D08C52	2022579	5	8	6.50	16.41	14.59	8.69	1.61	8.94	1/2	75
<b>7.5 Metric Tons</b>											
BC07D10D42	2022580	7.5	10	5.25	20.25	18.00	8.69	2.08	11.12	3/8	125
BC07D10D42	2022581	7.5	10	5.25	20.25	18.00	8.69	2.08	11.12	7/16	125
BC07D10D42	2022582	7.5	10	5.25	20.25	18.00	8.69	2.08	11.12	1/2	125
BC07D10D42	2022583	7.5	10	5.25	20.25	18.00	8.69	2.08	11.12	9/16	125
BC07D10D42	2022584	7.5	10	5.25	20.25	18.00	8.69	2.08	11.12	5/8	125
BC07D10D46	2022585	7.5	10	5.75	20.25	18.00	8.69	2.08	11.12	3/8	125
BC07D10D46	2022586	7.5	10	5.75	20.25	18.00	8.69	2.08	11.12	7/16	125
BC07D10D46	2022587	7.5	10	5.75	20.25	18.00	8.69	2.08	11.12	1/2	125
BC07D10D46	2022588	7.5	10	5.75	20.25	18.00	8.69	2.08	11.12	9/16	125
BC07D10D46	2022589	7.5	10	5.75	20.25	18.00	8.69	2.08	11.12	5/8	125
BC07D10D50	2022590	7.5	10	6.25	20.25	18.00	8.69	2.08	11.12	3/8	125
BC07D10D50	2022591	7.5	10	6.25	20.25	18.00	8.69	2.08	11.12	7/16	125
BC07D10D50	2022592	7.5	10	6.25	20.25	18.00	8.69	2.08	11.12	1/2	125
BC07D10D50	2022593	7.5	10	6.25	20.25	18.00	8.69	2.08	11.12	9/16	125
BC07D10D50	2022594	7.5	10	6.25	20.25	18.00	8.69	2.08	11.12	5/8	125
BC07D10E48	2022595	7.5	10	6.00	20.25	18.00	9.44	2.08	11.12	3/8	125
BC07D10E48	2022596	7.5	10	6.00	20.25	18.00	9.44	2.08	11.12	7/16	125
BC07D10E48	2022597	7.5	10	6.00	20.25	18.00	9.44	2.08	11.12	1/2	125
BC07D10E48	2022598	7.5	10	6.00	20.25	18.00	9.44	2.08	11.12	9/16	125
BC07D10E48	2022599	7.5	10	6.00	20.25	18.00	9.44	2.08	11.12	5/8	125
BC07D10E52	2022600	7.5	10	6.50	20.25	18.00	9.44	2.08	11.12	3/8	125
BC07D10E52	2022601	7.5	10	6.50	20.25	18.00	9.44	2.08	11.12	7/16	125
BC07D10E52	2022602	7.5	10	6.50	20.25	18.00	9.44	2.08	11.12	1/2	125
BC07D10E52	2022603	7.5	10	6.50	20.25	18.00	9.44	2.08	11.12	9/16	125
BC07D10E52	2022604	7.5	10	6.50	20.25	18.00	9.44	2.08	11.12	5/8	125
BC07D10E56	2022605	7.5	10	7.00	20.25	18.00	9.44	2.08	11.12	3/8	125
BC07D10E56	2022606	7.5	10	7.00	20.25	18.00	9.44	2.08	11.12	7/16	125
BC07D10E56	2022607	7.5	10	7.00	20.25	18.00	9.44	2.08	11.12	1/2	125
BC07D10E56	2022608	7.5	10	7.00	20.25	18.00	9.44	2.08	11.12	9/16	125
BC07D10E56	2022609	7.5	10	7.00	20.25	18.00	9.44	2.08	11.12	5/8	125
BC07D10F56	2022610	7.5	10	7.00	20.25	18.00	10.44	2.08	11.12	3/8	125
BC07D10F56	2022611	7.5	10	7.00	20.25	18.00	10.44	2.08	11.12	7/16	125
BC07D10F56	2022612	7.5	10	7.00	20.25	18.00	10.44	2.08	11.12	1/2	125
BC07D10F56	2022613	7.5	10	7.00	20.25	18.00	10.44	2.08	11.12	9/16	125
BC07D10F56	2022614	7.5	10	7.00	20.25	18.00	10.44	2.08	11.12	5/8	125
BC07D10F60	2022615	7.5	10	7.50	20.25	18.00	10.44	2.08	11.12	3/8	125
BC07D10F60	2022616	7.5	10	7.50	20.25	18.00	10.44	2.08	11.12	7/16	125
BC07D10F60	2022617	7.5	10	7.50	20.25	18.00	10.44	2.08	11.12	1/2	125
BC07D10F60	2022618	7.5	10	7.50	20.25	18.00	10.44	2.08	11.12	9/16	125
BC07D10F60	2022619	7.5	10	7.50	20.25	18.00	10.44	2.08	11.12	5/8	125

# McKissick® Overhead Bridge Crane Blocks

## 752 Series Bridge Crane Blocks

Model No.	BC-752 Stock No.	Working Load Limit (t)*	Sheave Diameter (in)	Dimensions (in)						Standard Wireline Size (in)	Weight Each (lb)
				A	B	C	D	E	F		
BC07D10F64	2022620	7.5	10	8.00	20.25	18.00	10.44	2.08	11.12	3/8	125
BC07D10F64	2022621	7.5	10	8.00	20.25	18.00	10.44	2.08	11.12	7/16	125
BC07D10F64	2022622	7.5	10	8.00	20.25	18.00	10.44	2.08	11.12	1/2	125
BC07D10F64	2022623	7.5	10	8.00	20.25	18.00	10.44	2.08	11.12	9/16	125
BC07D10F64	2022624	7.5	10	8.00	20.25	18.00	10.44	2.08	11.12	5/8	125
<b>10 Metric Tons</b>											
BC10D12G52	2022625	10	12	6.50	23.22	20.62	10.94	2.27	13.46	1/2	240
BC10D12G52	2022626	10	12	6.50	23.22	20.62	10.94	2.27	13.46	9/16	240
BC10D12G52	2022627	10	12	6.50	23.22	20.62	10.94	2.27	13.46	5/8	240
BC10D12G52	2022628	10	12	6.50	23.22	20.62	10.94	2.27	13.46	3/4	240
BC10D12G56	2022629	10	12	7.00	23.22	20.62	10.94	2.27	13.46	1/2	240
BC10D12G56	2022630	10	12	7.00	23.22	20.62	10.94	2.27	13.46	9/16	240
BC10D12G56	2022631	10	12	7.00	23.22	20.62	10.94	2.27	13.46	5/8	240
BC10D12G56	2022632	10	12	7.00	23.22	20.62	10.94	2.27	13.46	3/4	240
BC10D12G60	2022633	10	12	7.50	23.22	20.62	10.94	2.27	13.46	1/2	240
BC10D12G60	2022634	10	12	7.50	23.22	20.62	10.94	2.27	13.46	9/16	240
BC10D12G60	2022635	10	12	7.50	23.22	20.62	10.94	2.27	13.46	5/8	240
BC10D12G60	2022636	10	12	7.50	23.22	20.62	10.94	2.27	13.46	3/4	240
BC10D12G64	2022637	10	12	8.00	23.22	20.62	10.94	2.27	13.46	1/2	240
BC10D12G64	2022638	10	12	8.00	23.22	20.62	10.94	2.27	13.46	9/16	240
BC10D12G64	2022639	10	12	8.00	23.22	20.62	10.94	2.27	13.46	5/8	240
BC10D12G64	2022640	10	12	8.00	23.22	20.62	10.94	2.27	13.46	3/4	240
BC10D12I68	2022657	10	12	8.50	23.22	20.62	12.94	2.27	13.46	1/2	240
BC10D12I68	2022658	10	12	8.50	23.22	20.62	12.94	2.27	13.46	9/16	240
BC10D12I68	2022659	10	12	8.50	23.22	20.62	12.94	2.27	13.46	5/8	240
BC10D12I68	2022660	10	12	8.50	23.22	20.62	12.94	2.27	13.46	3/4	240
BC10D12I72	2022661	10	12	9.00	23.22	20.62	12.94	2.27	13.46	1/2	240
BC10D12I72	2022662	10	12	9.00	23.22	20.62	12.94	2.27	13.46	9/16	240
BC10D12I72	2022663	10	12	9.00	23.22	20.62	12.94	2.27	13.46	5/8	240
BC10D12I72	2022664	10	12	9.00	23.22	20.62	12.94	2.27	13.46	3/4	240
BC10D12I76	2022665	10	12	9.50	23.22	20.62	12.94	2.27	13.46	1/2	240
BC10D12I76	2022666	10	12	9.50	23.22	20.62	12.94	2.27	13.46	9/16	240
BC10D12I76	2022667	10	12	9.50	23.22	20.62	12.94	2.27	13.46	5/8	240
BC10D12I76	2022668	10	12	9.50	23.22	20.62	12.94	2.27	13.46	3/4	240
BC10D12I80	2022669	10	12	10.00	23.22	20.62	12.94	2.27	13.46	1/2	240
BC10D12I80	2022670	10	12	10.00	23.22	20.62	12.94	2.27	13.46	9/16	240
BC10D12I80	2022671	10	12	10.00	23.22	20.62	12.94	2.27	13.46	5/8	240
BC10D12I80	2022672	10	12	10.00	23.22	20.62	12.94	2.27	13.46	3/4	240
<b>15 Metric Tons</b>											
BC15D12J60	2022673	15	12	7.50	25.38	22.38	11.94	3.02	13.46	1/2	270
BC15D12J60	2022674	15	12	7.50	25.38	22.38	11.94	3.02	13.46	9/16	270
BC15D12J60	2022675	15	12	7.50	25.38	22.38	11.94	3.02	13.46	5/8	270
BC15D12J60	2022676	15	12	7.50	25.38	22.38	11.94	3.02	13.46	3/4	270
BC15D12J64	2022677	15	12	8.00	25.38	22.38	11.94	3.02	13.46	1/2	270
BC15D12J64	2022678	15	12	8.00	25.38	22.38	11.94	3.02	13.46	9/16	270
BC15D12J64	2022679	15	12	8.00	25.38	22.38	11.94	3.02	13.46	5/8	270
BC15D12J64	2022680	15	12	8.00	25.38	22.38	11.94	3.02	13.46	3/4	270
BC15D12J68	2022681	15	12	8.50	25.38	22.38	11.94	3.02	13.46	1/2	270
BC15D12J68	2022682	15	12	8.50	25.38	22.38	11.94	3.02	13.46	9/16	270
BC15D12J68	2022683	15	12	8.50	25.38	22.38	11.94	3.02	13.46	5/8	270
BC15D12J68	2022684	15	12	8.50	25.38	22.38	11.94	3.02	13.46	3/4	270
BC15D12J72	2022685	15	12	9.00	25.38	22.38	11.94	3.02	13.46	1/2	270
BC15D12J72	2022686	15	12	9.00	25.38	22.38	11.94	3.02	13.46	9/16	270
BC15D12J72	2022687	15	12	9.00	25.38	22.38	11.94	3.02	13.46	5/8	270
BC15D12J72	2022688	15	12	9.00	25.38	22.38	11.94	3.02	13.46	3/4	270
BC15D12L76	2022705	15	12	9.50	25.38	22.38	13.94	3.02	13.46	1/2	270
BC15D12L76	2022706	15	12	9.50	25.38	22.38	13.94	3.02	13.46	9/16	270
BC15D12L76	2022707	15	12	9.50	25.38	22.38	13.94	3.02	13.46	5/8	270
BC15D12L76	2022708	15	12	9.50	25.38	22.38	13.94	3.02	13.46	3/4	270
BC15D12L80	2022709	15	12	10.00	25.38	22.38	13.94	3.02	13.46	1/2	270
BC15D12L80	2022710	15	12	10.00	25.38	22.38	13.94	3.02	13.46	9/16	270
BC15D12L80	2022711	15	12	10.00	25.38	22.38	13.94	3.02	13.46	5/8	270
BC15D12L80	2022712	15	12	10.00	25.38	22.38	13.94	3.02	13.46	3/4	270
BC15D12L84	2022713	15	12	10.50	25.38	22.38	13.94	3.02	13.46	1/2	270
BC15D12L84	2022714	15	12	10.50	25.38	22.38	13.94	3.02	13.46	9/16	270
BC15D12L84	2022715	15	12	10.50	25.38	22.38	13.94	3.02	13.46	5/8	270
BC15D12L84	2022716	15	12	10.50	25.38	22.38	13.94	3.02	13.46	3/4	270
BC15D12L88	2022717	15	12	11.00	25.38	22.38	13.94	3.02	13.46	1/2	270
BC15D12L88	2022718	15	12	11.00	25.38	22.38	13.94	3.02	13.46	9/16	270
BC15D12L88	2022719	15	12	11.00	25.38	22.38	13.94	3.02	13.46	5/8	270
BC15D12L88	2022720	15	12	11.00	25.38	22.38	13.94	3.02	13.46	3/4	270

\* Ultimate Load is 5 times the Working Load Limit.

McKissick  
Blocks

**UB500 Series Top Swiveling Overhaul Balls**



All sizes are RFID EQUIPPED



With **S320** Eye Hook



With **S1316 A SHUR-LOC®** Eye Hook



Both styles available with optional **McKissick®** Wedge Socket Assembly or S-421 **TERMINATOR** Wedge Socket



**UWO 422T TERMINATOR** Wedge Only

- Sizes 4 Tons through 30 Tons available with Crosby's S1316A "Positive Locking" SHUR-LOC® hook which may be used for lifting personnel. Meets the intent of OSHA Rule 1926.1431(g)(1)(i)(A) and 1926.1501(g)(4)(iv)(B).
- Design Factor 4:1.
- The top swivel design on the UB500 assures the ball remains stationary if the Wireline spins.
- The swivel incorporates a sealed roller thrust bearing together with a grease fitting for easy lubrication
- Each ball can be equipped with the new McKissick® US-422T

Wedge Socket which can be easily adjusted to fit various size of Wireline by changing the wedge (Ensure that correct wedge is used for selected Wireline size).

- All hooks used on UB500 Overhaul Balls (S320, S320N & S1316A) are forged from alloy steel. The S320 and S320N hooks come complete with latches.
- The S320 hook (PL latch) and the S320N hook (S4320 latch), with the proper latch attached, may be used for personnel lifting when secured with proper device (Bolt, nut and pin for the PL latch; Cotter pin for the S4320 latch). Meets the intent of OSHA Rule 1926.1431(g)(1)(i)(A) and 1926.1501(g)(4)(iv)(B).

**Overhaul Ball Assembly**

**Optional US-422T Wedge Sockets**

McKissick® UB500 Model No.	UB500 "E" Eye Hook Stock No.	UB500 "S" SHUR-LOC® Stock No.	Working Load Limit (Tons)	Weight Each (lb)	Wireline Size (in)	Model No.	Wedge Socket Assy. Stock No.	Weight Each (lb)	Wedge Only Stock No.	Weight Each (lb)
MB4T35	1036000*	1036005	4	58	3/8	US4T	1044300	4.6	1047310	0.6
MB4T85	1036009*	1036018	4	102	7/16	US4T	1044309	4.6	1047301	0.6
MB4T150	1036027*	1036032	4	162	1/2	US4T	1044318	4.6	1047329	0.6
MB4T200	1036036*	1036041	4	201	1/2	US5T	1044327	8.5	1047338	1.0
MB7T85	1036045*	1036050	7	109	9/16	US5T	1044336	8.5	1047347	1.0
MB7T150	1036054*	1036063	7	170	5/8	US5T	1044345	8.5	1047356	1.0
MB7T200	1036072*	1036077	7	210	5/8	US6T	1044354	9.4	1047365	1.4
MB7T285	1036081*	1036086	7	321	3/4	US6T	1044363	9.4	1047374	1.4
MB10T150	1036090*	1036095	10	216						
MB10T200	1036099*	1036108	10	260						
MB10T285	1036117*	1036122	10	365	5/8	US6T	1044354	9.4	1047365	2.3
MB10T350	1036126*	1036131	10	403	3/4	US6T	1044363	9.4	1047374	2.4
MB10T650	1036135*	1036140	10	718	7/8	US8T	1044404	20.8	1047425	5.3
MB12T150	1036144*	1036520	12	216	1	US8T	1044417	20.8	1047431	6.0
MB12T200	1036153*	1036529	12	258	1-1/8	US10T	1044426	46.5	1047440	9.6
MB12T285	1036171*	1036538	12	365	1-1/4	US10T	1044435	46.5	1047459	10.5
MB12T350	1036180*	1036547	12	403						
MB12T650	1036189*	1036556	12	718						
MB15T200	1036198*	1036565	15	298						
MB15T350	1036207*	1036574	15	456						
MB15T650	1036216*	1036583	15	753						
MB15T1150	1036225*	1036592	15	1311						
MB20T200	1036234*	1036611	20	298	5/8	US8AT	1044372	17.5	1047383	3.1
MB20T350	1036243*	1036620	20	456	3/4	US8AT	1044381	17.5	1047392	3.4
MB20T650	1036252*	1036629	20	753	7/8	US8T	1044404	20.8	1047425	5.3
MB20T1150	1036261*	1036638	20	1311	1	US8T	1044417	20.8	1047431	6.0
MB25T350	1036270	1036647	25	533	1-1/8	US10T	1044426	46.5	1047440	9.6
MB25T650	1036279	1036656	25	865	1-1/4	US10T	1044435	46.5	1047459	10.5
MB25T1150	1036288	1036665	25	1421						
MB30T650	1036297	1036674	30	865						
MB30T1150	1036306	1036683	30	1421						

\* Utilizes Crosby "N" style hooks with integrated latch. Replacement latch kit is S-4320. PL latch and S-4055 latch will not fit. Standard Crosby S-5 Thrust style swivels can not be used with UB500 Overhaul Balls. For replacement swivels, contact Crosby Customer Service.

UB-500 TOP SWIVEL OVERHAUL BALLS



All sizes are RFID EQUIPPED.

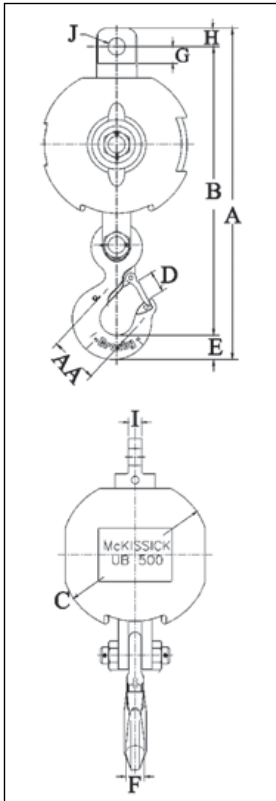

UB-500E Top Swivel Overhaul Balls with 320 Eye Hooks

Model No.*	UB-500 "E" Stock No.	Dimensions (in)										
		A	B	C	D	E	F	G	H	I	J	AA
MB4T35*	1036000	20.09	17.27	7.50	1.36	1.44	1.12	1.88	1.38	.88	1.31	2.5
MB4T85*	1036009	20.98	18.16	9.25	1.36	1.44	1.12	1.88	1.38	.88	1.31	2.5
MB4T150*	1036027	21.98	19.16	11.25	1.36	1.44	1.12	1.88	1.38	.88	1.31	2.5
MB4T200*	1036036	22.35	19.53	12.50	1.36	1.44	1.12	1.88	1.38	.88	1.31	2.5
MB7T85*	1036045	23.18	20.36	9.25	1.61	1.81	1.38	1.88	1.38	.88	1.31	3.0
MB7T150*	1036054	24.56	21.36	11.25	1.61	1.81	1.38	1.88	1.38	.88	1.31	3.0
MB7T200*	1036072	24.89	21.71	12.50	1.61	1.81	1.38	1.88	1.38	.88	1.31	3.0
MB7T285*	1036081	25.86	22.67	13.88	1.61	1.81	1.38	1.88	1.38	.88	1.31	3.0
MB10T150*	1036090	31.44	27.19	11.25	2.08	2.25	1.62	2.75	2.00	1.25	1.78	4.0
MB10T200*	1036099	31.81	27.56	12.50	2.08	2.25	1.62	2.75	2.00	1.25	1.78	4.0
MB10T285*	1036117	32.75	28.50	13.88	2.08	2.25	1.62	2.75	2.00	1.25	1.78	4.0
MB10T350*	1036126	33.31	29.06	15.00	2.08	2.25	1.62	2.75	2.00	1.25	1.78	4.0
MB10T650*	1036135	34.79	30.54	17.94	2.08	2.25	1.62	2.75	2.00	1.25	1.78	4.0
MB12T150*	1036144	31.44	27.19	11.25	2.08	2.25	1.62	2.75	2.00	1.25	1.78	4.0
MB12T200*	1036153	31.81	27.56	12.50	2.08	2.25	1.62	2.75	2.00	1.25	1.78	4.0
MB12T285*	1036171	32.75	28.50	13.88	2.08	2.25	1.62	2.75	2.00	1.25	1.78	4.0
MB12T350*	1036180	33.31	29.06	15.00	2.08	2.25	1.62	2.75	2.00	1.25	1.78	4.0
MB12T650*	1036189	35.79	30.54	17.94	2.08	2.25	1.62	2.75	2.00	1.25	1.78	4.0
MB15T200*	1036198	37.59	32.59	12.50	3.02	3.00	2.38	2.38	2.00	1.25	1.78	5.0
MB15T350*	1036207	38.81	33.81	15.00	3.02	3.00	2.38	2.38	2.00	1.25	1.78	5.0
MB15T650*	1036216	40.22	35.22	17.94	3.02	3.00	2.38	2.38	2.00	1.25	1.78	5.0
MB15T1150*	1036225	42.22	37.22	21.62	3.02	3.00	2.38	2.38	2.00	1.25	1.78	5.0
MB20T200*	1036234	37.59	32.59	12.50	3.02	3.00	2.38	2.38	2.00	1.25	1.78	5.0
MB20T350*	1036243	38.81	33.81	15.00	3.02	3.00	2.38	2.38	2.00	1.25	1.78	5.0
MB20T650*	1036252	40.22	35.22	17.94	3.02	3.00	2.38	2.38	2.00	1.25	1.78	5.0
MB20T1150*	1036261	42.22	37.22	21.62	3.02	3.00	2.38	2.38	2.00	1.25	1.78	5.0
MB25T350	1036270	47.18	40.18	15.00	3.00	3.62	3.00	3.31	2.75	1.75	1.78	6.5
MB25T650	1036279	49.12	42.75	17.94	3.00	3.62	3.00	3.31	2.75	1.75	1.78	6.5
MB25T1150	1036288	51.06	44.69	21.62	3.00	3.62	3.00	3.31	2.75	1.75	1.78	6.5
MB30T650	1036297	49.12	42.75	17.94	3.00	3.62	3.00	3.31	2.75	1.75	1.78	6.5
MB30T1150	1036306	51.06	44.69	21.62	3.00	3.62	3.00	3.31	2.75	1.75	1.78	6.5

\* 4 Ton thru 20 Ton models use Crosby "N" style hooks with integrated latch. All sizes are RFID EQUIPPED.

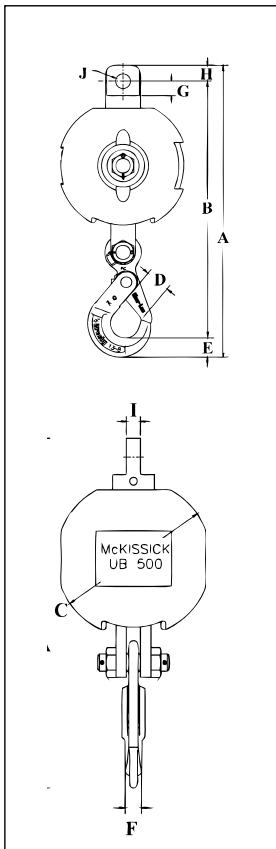

UB-500S Top Swivel Overhaul Balls with SHUR-LOC® Hooks

Model No.	UB-500 "S" Stock No.	Dimensions (in)									
		A	B	C	D	E	F	G	H	I	J
MB4T35	1036005	20.66	18.18	7.50	1.83	1.15	.94	1.88	1.38	.88	1.31
MB4T85	1036018	21.55	19.05	9.25	1.83	1.15	.94	1.88	1.38	.88	1.31
MB4T150	1036032	22.55	20.05	11.25	1.83	1.15	.94	1.88	1.38	.88	1.31
MB4T200	1036041	22.92	20.42	12.50	1.83	1.15	.94	1.88	1.38	.88	1.31
MB7T85	1036050	23.90	21.30	9.25	2.11	1.66	1.16	1.88	1.38	.88	1.31
MB7T150	1036063	25.28	22.30	11.25	2.11	1.66	1.16	1.88	1.38	.88	1.31
MB7T200	1036077	25.61	22.65	12.50	2.11	1.66	1.16	1.88	1.38	.88	1.31
MB7T285	1036086	26.58	23.61	13.88	2.11	1.66	1.16	1.88	1.38	.88	1.31
MB10T150	1036095	31.24	27.19	11.25	2.49	2.06	1.50	2.75	2.00	1.25	1.78
MB10T200	1036108	31.61	27.56	12.50	2.49	2.06	1.50	2.75	2.00	1.25	1.78
MB10T285	1036122	32.55	28.50	13.88	2.49	2.06	1.50	2.75	2.00	1.25	1.78
MB10T350	1036131	33.11	29.06	15.00	2.49	2.06	1.50	2.75	2.00	1.25	1.78
MB10T650	1036140	34.59	30.54	17.94	2.49	2.06	1.50	2.75	2.00	1.25	1.78
MB12T150	1036520	33.37	29.15	11.25	3.52	2.22	2.03	2.75	2.00	1.25	1.78
MB12T200	1036529	33.75	29.53	12.50	3.52	2.22	2.03	2.75	2.00	1.25	1.78
MB12T285	1036538	34.68	30.46	13.68	3.52	2.22	2.03	2.75	2.00	1.25	1.78
MB12T350	1036547	35.25	31.03	15.00	3.52	2.22	2.03	2.75	2.00	1.25	1.78
MB12T650	1036556	36.72	32.50	17.94	3.52	2.22	2.03	2.75	2.00	1.25	1.78
MB15T200	1036565	36.67	32.22	12.5	3.83	2.45	2.20	2.38	2.00	1.25	1.78
MB15T350	1036574	37.89	33.44	15.0	3.83	2.45	2.20	2.38	2.00	1.25	1.78
MB15T650	1036583	39.30	34.85	17.94	3.83	2.45	2.20	2.38	2.00	1.25	1.78
MB15T1150	1036592	41.30	36.85	21.63	3.83	2.45	2.20	2.38	2.00	1.25	1.78
MB20T200	1036611	36.67	32.33	12.50	3.83	2.45	2.20	2.38	2.00	1.25	1.78
MB20T350	1036620	37.89	33.44	15.0	3.83	2.45	2.20	2.38	2.00	1.25	1.78
MB20T650	1036629	39.30	34.85	17.94	3.83	2.45	2.20	2.75	2.00	1.25	1.78
MB20T1150	1036638	41.30	36.85	21.63	3.83	2.45	2.20	2.75	2.00	1.25	1.78
MB25T350	1036647	46.17	40.21	15.00	4.09	3.21	2.68	3.50	2.75	1.75	1.78
MB25T650	1036656	48.11	42.15	17.94	4.09	3.21	2.68	3.50	2.75	1.75	1.78
MB25T1150	1036665	50.04	44.08	21.63	4.09	3.21	2.68	3.50	2.75	1.75	1.78
MB30T650	1036674	48.11	42.15	17.94	4.09	3.21	2.68	3.50	2.75	1.75	1.78
MB30T1150	1036683	50.04	44.08	21.63	4.09	3.21	2.68	3.50	2.75	1.75	1.78

All sizes are RFID EQUIPPED.

McKissick Blocks



**UB500 Series Non Swiveling Overhaul Balls**



All sizes are RFID EQUIPPED



Key to McKissick® UB500 Utility Overhaul Ball Model Number				
<b>MB</b>	<b>4</b>	<b>T</b>	<b>35</b>	<b>E</b>
↓	↓	↓	↓	↓
McKissick® Utility Overhead Ball	Working Load Limit (Tons)	Swivel Style T = Top NS = Non	Ball Only Weight	Hook Style E = 320 or 320N S = SHUR-LOC® Eye Hook



**S320**  
Eye Hook



**S1316 A**  
**SHUR-LOC®**  
Eye Hook



Both styles available with optional McKissick® Wedge Socket Assembly or S-421 **TERMINATOR** Wedge Socket



**UWO 422T**  
**TERMINATOR**  
Wedge Only

- Sizes 4 Tons through 15 Tons available with Crosby's S1316A "Positive Locking" SHUR-LOC® hook which may be used for lifting personnel. Meets the intent of OSHA Rule 1926.1431(g)(1)(i)(A) and 1926.1501(g)(4)(iv)(B).
- Design Factor 4:1.
- Each ball can be equipped with the new McKissick® US-422T Wedge Socket which can be easily adjusted to fit various sizes of Wireline by changing the wedge (Ensure that correct wedge is used for selected Wireline size).
- All hooks used on UB500 Overhaul Balls (S320, S320N & S1316A) are forged from alloy steel. The S320 and S320N hooks come complete with latches.
- The S320 hook (PL latch) and the S320N hook (S4320 latch), with the proper latch attached, may be used for personnel lifting when secured with proper device (Bolt, nut and pin for the PL latch; Cotter pin for the S4320 latch). Meets the intent of OSHA Rule 1926.1431(g)(1)(i)(A) and 1926.1501(g)(4)(iv)(B).

**Overhaul Ball Assembly**

**Optional US-422T Wedge Sockets**

McKissick® UB500 Model No.	UB500 "E" Eye Hook Stock No.	UB500 "S" SHUR-LOC® Stock No.	Working Load Limit (Tons)	Weight Each (lb)	Wireline Size (in)	Model No.	Wedge Socket Assy. Stock No.	Weight Each (lb)	Wedge Only Stock No.	Weight Each (lb)
MB4NS35	1036402*	1036407	4	54						
MB4NS85	1036411*	1036416	4	98	3/8	US4T	1044300	4.6	1047310	0.6
MB4NS150	1036420*	1036425	4	158	7/16	US4T	1044309	4.6	1047301	0.6
MB4NS200	1036429*	1036434	4	200	1/2	US4T	1044318	4.6	1047329	0.6
MS7NS85	1036438*	1036443	7	104	9/16	US5T	1044327	8.5	1047338	1.0
MB7NS150	1036447*	1036452	7	165	5/8	US5T	1044336	8.5	1047347	1.0
MB7NS200	1036456*	1036461	7	205	5/8	US5T	1044345	8.5	1047356	1.0
MB7NS285	1036465*	1036470	7	316	3/4	US6T	1044354	9.4	1047365	1.4
MB10NS150	1036474*	1036479	10	198						
MB10NS200	1036483*	1036488	10	242						
MB10NS285	1036492*	1036497	10	347						
MB10NS350	1036501*	1036506	10	385	5/8	US6T	1044354	9.4	1047365	1.4
MB10NS650	1036510*	1036511	10	700	3/4	US6T	1044363	9.4	1047374	1.4
MB12NS150	1036519*	-	12	198	7/8	US8T	1044404	20.8	1047425	7.6
MB12NS200	1036528*	-	12	240	1	US8T	1044417	20.8	1047431	8.6
MB12NS285	1036537*	-	12	347	1-1/8	US10T	1044426	46.5	1047440	12.5
MB12NS350	1036546*	-	12	385	1-1/4	US10T	1044435	46.5	1047459	15.0
MB12NS650	1036555*	-	12	700						
MB15NS200	1036564*	-	15	267	5/8	US8AT	1044372	17.5	1047383	4.3
MB15NS350	1036573*	-	15	425	3/4	US8AT	1044381	17.5	1047392	4.8
MB15NS650	1036582*	-	15	722	7/8	US8T	1044404	20.8	1047425	7.6
MB15NS1150	1036591*	-	15	1280	1	US8T	1044417	20.8	1047431	8.6
					1-1/8	US10T	1044426	46.5	1047440	12.5
					1-1/4	US10T	1044435	46.5	1047459	15.0

\* Utilizes Crosby "N" style hooks with integrated latch. Replacement latch kit is S-4320. PL latch and S-4055 latch will not fit

UB-500 NON SWIVEL OVERHAUL BALLS



All sizes are RFID EQUIPPED.

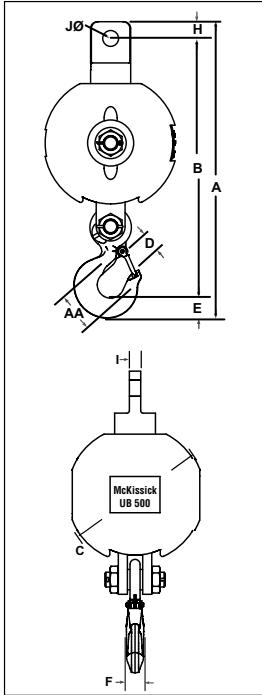

UB-500NS Non Swivel Overhaul Balls with 320N Eye Hooks

Model No.	UB-500 "E" Stock No.	Dimensions (in)									
		A	B	C	D	E	F	H	I	J	AA
MB4NS35	1036402	20.09	17.27	7.5	1.36	1.44	1.12	1.38	0.75	1.31	2.5
MB4NS85	1036411	20.98	18.16	9.25	1.36	1.44	1.12	1.38	0.75	1.31	2.5
MB4NS150	1036420	21.98	19.16	11.25	1.36	1.44	1.12	1.38	0.75	1.31	2.5
MB4NS200	1036429	22.35	19.53	12.5	1.36	1.44	1.12	1.38	0.75	1.31	2.5
MB7NS85	1036438	23.18	20.36	9.25	1.61	1.81	1.38	1.38	0.75	1.31	3.0
MB7NS150	1036447	24.56	21.36	11.25	1.61	1.81	1.38	1.38	0.75	1.31	3.0
MB7NS200	1036456	24.89	21.71	12.5	1.61	1.81	1.38	1.38	0.75	1.31	3.0
MB7NS285	1036465	25.86	22.67	13.88	1.61	1.81	1.38	1.38	0.75	1.31	3.0
MB10NS150	1036474	31.44	27.19	11.25	2.08	2.25	1.62	2.00	1.25	1.78	4.0
MB10NS200	1036483	31.81	27.56	12.5	2.08	2.25	1.62	2.00	1.25	1.78	4.0
MB10NS285	1036492	32.75	28.5	13.88	2.08	2.25	1.62	2.00	1.25	1.78	4.0
MB10NS350	1036501	33.31	29.06	15.00	2.08	2.25	1.62	2.00	1.25	1.78	4.0
MB10NS650	1036510	34.79	30.54	17.94	2.08	2.25	1.62	2.00	1.25	1.78	4.0
MB12NS150	1036519	31.44	27.19	11.25	2.08	2.25	1.62	2.00	1.25	1.78	4.0
MB12NS200	1036528	31.81	27.56	12.5	2.08	2.25	1.62	2.00	1.25	1.78	4.0
MB12NS285	1036537	32.75	28.5	13.88	2.08	2.25	1.62	2.00	1.25	1.78	4.0
MB12NS350	1036546	33.31	29.06	15.00	2.08	2.25	1.62	2.00	1.25	1.78	4.0
MB12NS650	1036555	35.79	30.54	17.94	2.08	2.25	1.62	2.00	1.25	1.78	4.0
MB15NS200	1036564	37.59	32.59	12.5	3.02	3.00	2.38	2.00	1.25	1.78	5.0
MB15NS350	1036573	38.81	33.81	15.00	3.02	3.00	2.38	2.00	1.25	1.78	5.0
MB15NS650	1036582	40.22	35.22	17.94	3.02	3.00	2.38	2.00	1.25	1.78	5.0
MB15NS1150	1036591	42.22	37.22	21.62	3.02	3.00	2.38	2.00	1.25	1.78	5.0

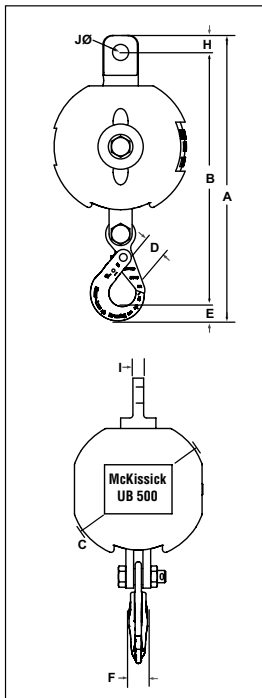

UB-500NS Non Swivel Overhaul Balls with SHUR-LOC® Hooks

Model No.	UB-500 "S" Stock No.	Dimensions (in)									
		A	B	C	D	E	F	H	I	J	
MB4NS35	1036407	20.66	18.18	7.5	1.83	1.15	0.94	1.38	0.75	1.31	
MB4NS85	1036416	21.55	19.05	9.25	1.83	1.15	0.94	1.38	0.75	1.31	
MB4NS150	1036425	22.55	20.05	11.25	1.83	1.15	0.94	1.38	0.75	1.31	
MB4NS200	1036434	22.92	20.42	12.5	1.83	1.15	0.94	1.38	0.75	1.31	
MB7NS85	1036443	23.9	21.3	9.25	2.11	1.66	1.16	1.38	0.75	1.31	
MB7NS150	1036452	25.28	22.3	11.25	2.11	1.66	1.16	1.38	0.75	1.31	
MB7NS200	1036461	25.61	22.65	12.5	2.11	1.66	1.16	1.38	0.75	1.31	
MB7NS285	1036470	26.58	23.61	13.88	2.11	1.66	1.16	1.38	0.75	1.31	
MB10NS150	1036479	31.24	27.19	11.25	2.49	2.06	1.5	2.00	1.25	1.78	
MB10NS200	1036488	31.61	27.56	12.5	2.49	2.06	1.5	2.00	1.25	1.78	
MB10NS285	1036497	32.55	28.5	13.88	2.49	2.06	1.5	2.00	1.25	1.78	
MB10NS350	1036506	33.11	29.06	15.00	2.49	2.06	1.5	2.00	1.25	1.78	
MB10NS650	1036511	34.59	30.54	17.94	2.49	2.06	1.5	2.00	1.25	1.78	

McKissick Blocks



**Split Overhaul Ball**

- Attaches easily to Wireline.

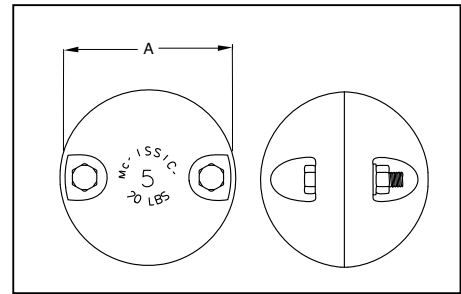

**Split Overhaul Ball**

Catalog No.	Stock No.	Wireline Size (in)	Weight Each (lb)	Belt Diameter A (in)
SHB - 15	2003822	1/4-5/16	15	5.06
SHB - 20	2003830	3/8	20	5.38
SHB - 50	2003831	1/2 - 5/8	50	7.12
SHB - 100	2003832	5/8 - 3/4 - 7/8	100	9.19



**AS-15 Overhaul Ball**

- Utilize genuine Crosby hooks which are forged alloy steel, Quenched and Tempered and contain the patented **QUIC-CHECK®** marking.
- Entire overhaul ball is zinc plated to resist corrosion.
- Designed with angular contact bearings which maximize efficiency, reliability and service life of swivel and extend the life of the Wireline.
- Available with wide jaw opening that utilizes nylon spools and shields.
- Designed for applications where headroom is critical.
- Other upper fittings available upon request

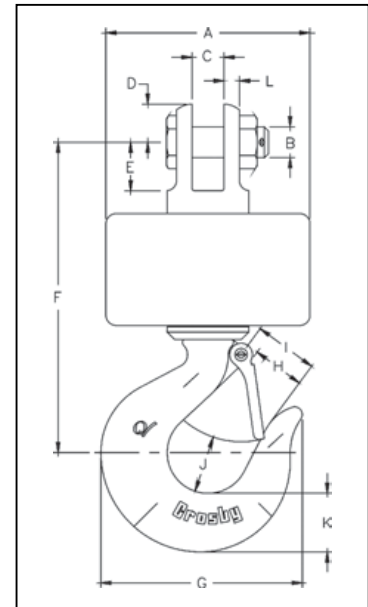

**Angular Contact Bearing Swivel Overhaul Balls**

AS-15 Stock No.	Working Load Limit (Tons)*	Wireline Size (in)	Dimensions (in)												Weight Each (lb)
			A	B	C	D	E	F	G	H	I	J	K	L	
2009806	1.5	.38	4.00	.50	.50	.69	.78	6.28	4.09	1.12	1.22	1.19	1.12	.31	9
2009807	3.0	.50	5.00	.75	.75	.94	1.19	8.56	4.94	1.34	1.50	1.38	1.44	.38	19
2003969	5.0	.62	6.88	.88	1.06	1.12	1.56	10.81	6.50	1.69	1.88	1.75	1.81	.56	43
2009808	8.5	.75	7.00	1.19	1.56	1.34	2.09	13.75	8.69	2.25	2.50	2.56	2.59	.53	60

\* Ultimate Load is 5 times the Working Load Limit.

# McKissick® Overhaul Balls



**UB-550E**  
Overhaul  
Ball

**Top Swivel Design assures that the ball remains stationary if the wireline spins.**

Available in a variety of configurations

- 4 & 7 Ton capacities
- 85, 150 & 200 lb. weights (ball only)
- Crosby S-320AN Eye Hook or S-1316 SHUR-LOC® Hooks.
- Utilize genuine forged Crosby hooks, bail and connector.
  - Quenched and Tempered
- Both styles of hooks incorporate patented **QUIC-CHECK®** markings forged into the product which address two **QUIC-CHECK®** features:
  - Deformation Indicators and Angle Indicators.
- Easy disassembly for periodic inspection and maintenance.
- Design factor of 4:1.
- All sizes are **RFID EQUIPPED**.



**UB-550S**  
Overhaul  
Ball

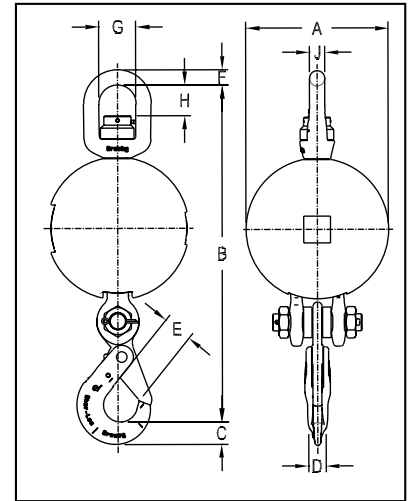
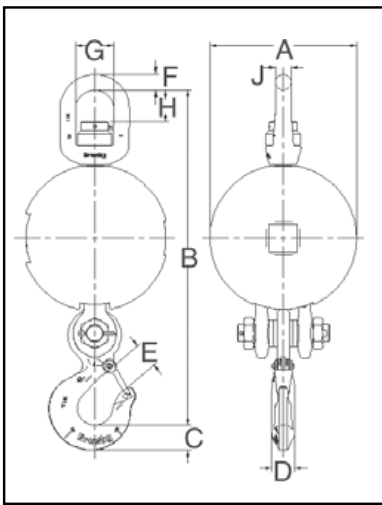

## UB-550E Top Swivel Overhaul Balls with Crosby Eye Hook

UB-550E Stock No.	Model No.	Working Load Limit (Tons)*	Weight Each (lb)	Dimensions (in)								
				A	B	C	D	E	F	G	H	J
1036621	MB04BT085E	4	113	8.88	21.00	1.44	1.31	1.36	1.12	2.75	2.28	1.12
1036649	MB04BT150E	4	178	10.56	22.72	1.44	1.31	1.36	1.12	2.75	2.28	1.12
1036667	MB04BT200E	4	232	11.62	23.72	1.44	1.31	1.36	1.12	2.75	2.28	1.12
1036685	MB07BT085E	7	113	8.88	22.48	1.81	1.66	1.61	1.12	2.75	2.28	1.12
1036705	MB07BT150E	7	178	10.56	24.20	1.81	1.66	1.61	1.12	2.75	2.28	1.12
1036723	MB07BT200E	7	232	11.62	25.20	1.81	1.66	1.61	1.12	2.75	2.28	1.12

\* Ultimate Load is 4 times the Working Load Limit.

## UB-550S Top Swivel Overhaul Balls with SHUR-LOC® Eye Hook

UB-550S Stock No.	Model No.	Working Load Limit (Tons)*	Weight Each (lb)	Dimensions (in)								
				A	B	C	D	E	F	G	H	J
1036630	MB04BT085S	4	113	8.88	23.32	1.67	1.16	2.11	1.12	2.75	2.28	1.12
1036658	MB04BT150S	4	178	10.56	25.04	1.67	1.16	2.11	1.12	2.75	2.28	1.12
1036676	MB04BT200S	4	232	11.62	26.04	1.67	1.16	2.11	1.12	2.75	2.28	1.12
1036694	MB07BT085S	7	113	8.88	23.32	1.67	1.16	2.11	1.12	2.75	2.28	1.12
1036714	MB07BT150S	7	178	10.56	25.04	1.67	1.16	2.11	1.12	2.75	2.28	1.12
1036732	MB07BT200S	7	232	11.62	26.04	1.67	1.16	2.11	1.12	2.75	2.28	1.12

\* Ultimate Load is 4 times the Working Load Limit.



From a 2 ton capacity snatch Block to a 6000 metric ton capacity crane Block, McKissick® can make a block to fit your lifting needs. In the lifting tackle industry, the name McKissick has stood for quality for almost 80 years.



McKissick's major involvement in the block business came after 1925. At that time, laws were passed requiring safety guards on the WireLine entrance to oilfield blocks. It was McKissick that developed and patented a WireLine guard that could be opened to allow the reeving of the block without disassembly.

Through product diversification, and 100 patents later, McKissick manufactures blocks and sheaves for many market uses including construction, industrial, military, energy and marine applications. From the many "off the shelf" items, to the non-standard "Special Engineered" block and tackle systems, McKissick prides itself on meeting your lifting needs.

McKissick, a part of The Crosby Group LLC since 1959, is not only one of the world's largest producers of blocks, they also manufacture the world's largest block and tackle systems. Notable examples of custom blocks manufactured by McKissick include those used to set the NASA space shuttle on the back of the 747 carrier jet.

The largest and most impressive example of McKissick's capabilities is the M-5000 block (6000 metric ton capacity) for McDermott's DB-102 derrick barge.

McKissick is an ISO 9001 certified facility. That, in addition to being an API Q1 producer, reinforced McKissick's, as well as Crosby's, commitment to continued quality.

McKissick® products, another reason to say:



***"When buying Crosby you're buying more than product, you're buying Quality."***



Licensed Under  
API Spec 8C-0021



# Crosby®

[www.thecrosbygroup.com](http://www.thecrosbygroup.com)  
[crosbygroup@thecrosbygroup.com](mailto:crosbygroup@thecrosbygroup.com)

## SHACKLE FITTING, SINGLE SHEAVE, 2-12t



419



L-170



L-160



417

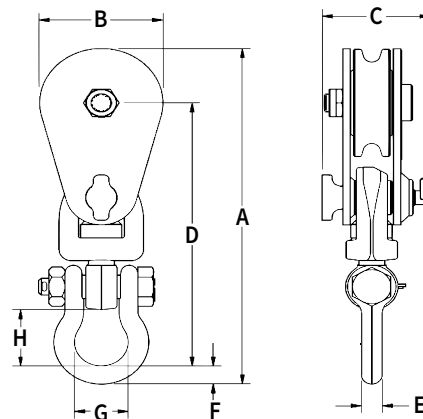

- Opening feature permits easy insertion of rope without reeving, or while the block is suspended.
- Bolt for opening feature is retained, to ensure no lost bolts.
- Forged steel swivel tees, yokes and shackles.
- Can be furnished with bronze bushings or roller bearings.
- Center pin equipped with pressure lube fitting.
- All sizes feature sheave grooves suited for a range of wire line diameters.
- Meets or exceeds all requirements of ASME B30.26 including identification ductility, design factor, proof load and temperature requirements. Importantly, these blocks meet other critical performance requirements including fatigue life and material traceability, not addressed by ASME B30.26.
- "All Alloy" snatch blocks feature a significant reduction in weight compared to snatch blocks made of non-alloy materials.
- "Lebus, General Purpose" snatch blocks (with shackle or hook) feature an easy-to-open bolt design. The retaining bolt is released by rotating the fitting assembly, no tools required.
- Crosby's Engineered Solutions Group is ready to discuss your requirements and help select or develop the ideal block for your application. Call us at 1-800-777-1555.

Working Load Limit (t)*	Wire Rope Size (in)	Sheave Diameter (in)	Bearing Code	Weight Each (lb)	Catalog No.	Description	Stock No.	Dimensions (in)							
								A	B	C	D	E	F	G	H
2 tonnes															
2	5/16 - 3/8	3	BB	4	419 w/Eye	Light Champion	109037 †	8.67	3.00	2.64	6.61	0.56	0.56	1.38	1.38
2	5/16 - 3/8	3	BB	5	419	Light Champion	109091	9.27	3.00	2.64	7.27	0.50	0.50	1.32	1.56
4 tonnes															
4	3/8 - 1/2	4.5	BB	12	419	Light Champion	109064	13.38	4.24	3.13	10.57	0.62	0.69	1.70	2.00
5 tonnes															
5	3/8 - 1/2 ‡	4	BB	11	L-170	Lebus, General Purpose	599828	13.88	4.50	2.94	10.94	0.62	0.69	1.70	2.00
5	3/8 - 1/2 ‡	4	RB	11	L-170	Lebus, General Purpose	599837	13.88	4.50	2.94	10.94	0.62	0.69	1.70	2.00
6 tonnes															
6**	3/8 - 1/2	5	BB	13	L-160	Lebus, Heavy Duty	599524	13.82	5.12	3.69	10.57	0.62	0.69	1.70	2.00
6**	3/8 - 1/2	5	RB	13	L-160	Lebus, Heavy Duty	599533	13.82	5.12	3.69	10.57	0.62	0.69	1.70	2.00
8 tonnes															
8	5/8 - 3/4	6	BB	28	419	Light Champion	109126	18.93	6.00	4.19	14.68	1.25	1.25	3.00	3.47
8	5/8 - 3/4	6	RB	28	419	Light Champion	109153	18.93	6.00	4.19	14.68	1.25	1.25	3.00	3.47
8	5/8 - 3/4	8	BB	33	419	Light Champion	109224	20.99	8.12	4.19	15.68	1.25	1.25	3.00	3.47
8	5/8 - 3/4	8	RB	33	419	Light Champion	109251	20.99	8.12	4.19	15.68	1.25	1.25	3.00	3.47
8	5/8 - 3/4	10	BB	43	419	Light Champion	109322	23.06	10.12	4.19	16.75	1.25	1.25	3.00	3.47
8	5/8 - 3/4	10	RB	43	419	Light Champion	109359	23.06	10.12	4.19	16.75	1.25	1.25	3.00	3.47
8	5/8 - 3/4	12	BB	55	419	Light Champion	109420	25.87	12.12	4.19	18.56	1.25	1.25	3.00	3.47
8	5/8 - 3/4	12	RB	55	419	Light Champion	109457	25.87	12.12	4.19	18.56	1.25	1.25	3.00	3.47
8	5/8 - 3/4	14	BB	67	419	Light Champion	109527	27.37	14.12	4.19	19.06	1.25	1.25	3.00	3.47
8	5/8 - 3/4	14	RB	67	419	Light Champion	109545	27.37	14.12	4.19	19.06	1.25	1.25	3.00	3.47
12 tonnes															
12**	5/8 - 3/4	5.75	BB	29	L-160	Lebus, Heavy Duty	599588	19.03	6.00	4.19	14.78	1.25	1.25	3.00	3.47
12**	5/8 - 3/4	5.75	RB	29	L-160	Lebus, Heavy Duty	599597	19.03	6.00	4.19	14.78	1.25	1.25	3.00	3.47
12	3/4 - 7/8	6	BB	28	417	All Alloy	168972	18.93	6.00	4.19	14.68	1.25	1.25	3.00	3.47
12	3/4 - 7/8	6	RB	28	417	All Alloy	193757	18.93	6.00	4.19	14.68	1.25	1.25	3.00	3.47
12	3/4 - 7/8	8	BB	34	417	All Alloy	168990	20.99	8.12	4.19	15.68	1.25	1.25	3.00	3.47
12	3/4 - 7/8	8	RB	34	417	All Alloy	193819	20.99	8.12	4.19	15.68	1.25	1.25	3.00	3.47
12	3/4 - 7/8	10	BB	42	417	All Alloy	193882	23.06	10.12	4.19	16.75	1.25	1.25	3.00	3.47
12	3/4 - 7/8	10	RB	42	417	All Alloy	193935	23.06	10.12	4.19	16.75	1.25	1.25	3.00	3.47

\* Ultimate Load is 4 times the Working Load Limit. \*\* Ultimate Load is 3.5 times the Working Load Limit. † Fitted with 1-1/4" ID Swivel Eye. ‡ Special Dual Groove Sheave also accepts 1-1/4" Manilla Rope.

McKissick Blocks

## SHACKLE FITTING, SINGLE SHEAVE, 15-60t

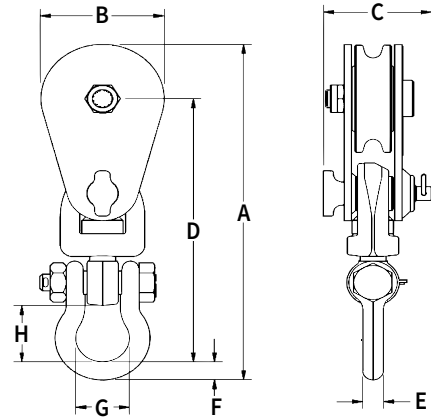

- Opening feature permits easy insertion of rope without reeving, or while the block is suspended.
- Bolt for opening feature is retained, to ensure no lost bolts.
- Forged steel swivel tees, yokes and shackles.
- Can be furnished with bronze bushings or roller bearings.
- Center pin equipped with pressure lube fitting.
- All sizes feature sheave grooves suited for a range of wire line diameters.
- Meets or exceeds all requirements of ASME B30.26 including identification, ductility, design factor, proof load and temperature requirements.

Importantly, these blocks meet other critical performance requirements including fatigue life and material traceability, not addressed by ASME B30.26.

- All blocks are RFID EQUIPPED.
- "All Alloy" snatch blocks feature a significant reduction in weight compared to snatch blocks made of non-alloy materials.
- Crosby's Engineered Solutions Group is ready to discuss your requirements and help select or develop the ideal block for your application. Call us at 1-800-777-1555.

Working Load Limit (t)*	Wire Rope Size (in)	Sheave Diameter (in)	Bearing Code	Weight Each (lb)	Catalog No.	Description	Stock No.	Dimensions (in)															
								A	B	C	D	E	F	G	H								
15 tonnes																							
15	3/4 - 7/8	8	BB	59	421	Champion	108308	23.00	8.12	5.09	17.19	1.50	1.75	3.12	3.12								
15	3/4 - 7/8	8	RB	59	421	Champion	108309	23.00	8.12	5.09	17.19	1.50	1.75	3.12	3.12								
15	3/4 - 7/8	10	BB	68	421	Champion	108390	24.75	10.12	5.09	17.94	1.50	1.75	3.12	3.12								
15	3/4 - 7/8	10	RB	68	421	Champion	108391	24.75	10.12	5.09	17.94	1.50	1.75	3.12	3.12								
15	3/4 - 7/8	16	BB	130	419	Light Champion	109607	31.75	16.12	5.09	22.00	1.50	1.75	3.12	3.12								
15	3/4 - 7/8	16	RB	130	419	Light Champion	109625	31.75	16.12	5.09	22.00	1.50	1.75	3.12	3.12								
15	7/8 - 1	18	BB	159	419	Light Champion	109643	33.12	18.12	5.09	22.25	1.50	1.75	3.12	3.12								
15	7/8 - 1	18	RB	159	419	Light Champion	109661	33.12	18.12	5.09	22.25	1.50	1.75	3.12	3.12								
20 tonnes																							
20	1 - 1-1/8	8	BB	92	431	Super Champion	121022	26.57	8.12	6.00	19.76	2.00	2.75	3.72	4.00								
20	1 - 1-1/8	8	RB	92	431	Super Champion	121040	26.57	8.12	6.00	19.76	2.00	2.75	3.72	4.00								
20	1 - 1-1/8	10	BB	112	431	Super Champion	121095	28.64	10.12	6.00	20.72	2.00	2.75	3.72	4.00								
20	1 - 1-1/8	10	RB	112	431	Super Champion	121111	28.64	10.12	6.00	20.72	2.00	2.75	3.72	4.00								
20	1 - 1-1/8	12	BB	130	431	Super Champion	121175	30.65	12.25	6.00	21.78	2.00	2.75	3.72	4.00								
20	1 - 1-1/8	12	RB	130	431	Super Champion	121193	30.65	12.25	6.00	21.78	2.00	2.75	3.72	4.00								
20	1 - 1-1/8	14	BB	160	431	Super Champion	121255	33.00	14.00	6.00	23.25	2.00	2.75	3.72	4.00								
20	1 - 1-1/8	14	RB	160	431	Super Champion	121273	33.00	14.00	6.00	23.25	2.00	2.75	3.72	4.00								
25 tonnes																							
25	1 - 1-1/4	8	BB	103	435	All Alloy High Capacity	208954	27.08	8.25	6.13	20.21	2.00	2.75	3.72	4.00								
25	1 - 1-1/4	10	BB	117	435	All Alloy High Capacity	208965	29.33	10.24	6.13	21.46	2.00	2.75	3.72	4.00								
25	1 - 1-1/4	18	BB	270	431	Super Champion	119495	41.36	18.25	7.13	29.12	2.00	3.12	3.50	4.81								
25	1 - 1-1/4	18	RB	280	431	Super Champion	119496	41.36	18.25	7.13	29.12	2.00	3.12	3.50	4.81								
30 tonnes																							
30	1 - 1-1/4	12	BB	208	435	All Alloy High Capacity	208976	36.61	12.25	7.00	27.37	2.00	3.12	3.50	4.81								
30	1 - 1-1/4	14	BB	230	435	All Alloy High Capacity	208977	38.86	14.25	7.00	28.62	2.00	3.12	3.50	4.81								
30	1 - 1-1/4	20	BB	503	431	Super Champion	119589	52.40	20.25	8.31	38.34	2.50	3.94	5.62	7.06								
30	1 - 1-1/4	20	RB	485	431	Super Champion	119598	52.40	20.25	8.31	38.34	2.50	3.94	5.62	7.06								
30	1 - 1-1/4	24	BB	581	431	Super Champion	119605	56.00	24.25	8.31	40.00	2.50	3.94	5.62	7.06								
30	1 - 1-1/4	24	RB	575	431	Super Champion	119614	56.00	24.25	8.31	40.00	2.50	3.94	5.62	7.06								
60 tonnes																							
60	1 - 1-1/4	12	BB	315	435	All Alloy High Capacity	8027291	41.65	12.12	8.66	33.19	2.06	2.40	5.75	6.12								

\* Ultimate Load is 4 times the Working Load Limit.



## HOOK FITTING, SINGLE SHEAVE, 2-12t



416



L-170



L-160



C-720

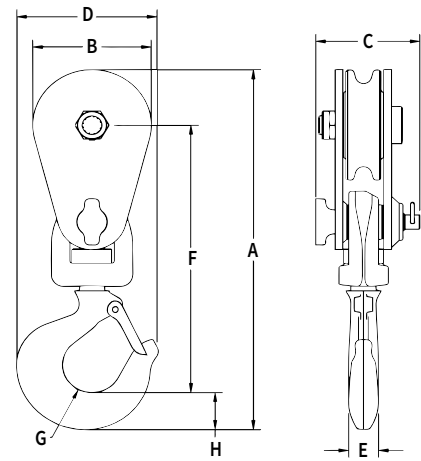

- Opening feature permits easy insertion of rope without reeving, or while the block is suspended.
- Bolt for opening feature is retained, to ensure no lost bolts.
- Forged steel swivel tees, yokes and hooks.
- Furnished with a latch installed.
- Can be furnished with bronze bushings or roller bearings.
- Center pin equipped with pressure lube fitting.
- All sizes feature sheave grooves suited for a range of wire line diameters.
- Meets or exceeds all requirements of ASME B30.26 including identification ductility, design factor, proof load and temperature requirements.

Importantly, these blocks meet other critical performance requirements including fatigue life and material traceability, not addressed by ASME B30.26.

- "All Alloy" snatch blocks feature a significant reduction in weight compared to snatch blocks made of non-alloy materials.
- "Lebus General Purpose" snatch blocks (with shackle or hook) feature an easy-to-open bolt design. The retaining bolt is released by rotating the fitting assembly, no tools required.
- Crosby's Engineered Solutions Group is ready to discuss your requirements and help select or develop the ideal block for your application. Call us at 1-800-777-1555.

Working Load Limit (t)*	Wire Rope Size (in)	Sheave Diameter (in)	Bearing Code	Weight Each (lb)	Catalog No.	Description	Stock No.	Dimensions (in)							
								A	B	C	D	E	F	G	H
2 tonnes															
2	5/16 - 3/8	3	BB	5	418	Light Champion	108038	9.74	3.00	2.64	3.59	0.75	7.24	0.75	1.00
4 tonnes															
4	3/8 - 1/2	4.5	BB	12	418	Light Champion	108065	14.12	4.24	3.13	5.24	1.00	10.13	0.94	1.87
5 tonnes															
5	3/8 - 1/2 ‡	4	BB	11	L-170	Lebus, General Purpose	599800	14.62	4.56	2.94	5.24	1.00	10.50	0.94	1.87
5	3/8 - 1/2 ‡	4	RB	11	L-170	Lebus, General Purpose	599819	14.62	4.56	2.94	5.24	1.00	10.50	0.94	1.87
6 tonnes															
6**	3/8 - 1/2	5	BB	13	L-160	Lebus, Heavy Duty	599506	14.56	5.12	3.69	5.24	1.00	10.13	0.94	1.87
6**	3/8 - 1/2	5	RB	13	L-160	Lebus, Heavy Duty	599515	14.56	5.12	3.69	5.24	1.00	10.13	0.94	1.87
7 Tons															
7T**	3/4 - 7/8	6	BB	28	C-720	Heavy Duty Utility	280010	16.14	6.00	3.81	6.27	1.44	11.33	1.25	1.61
8 tonnes															
8	5/8 - 3/4	6	BB	27	418	Light Champion	108127	18.95	6.00	4.19	6.81	1.56	13.55	1.31	2.41
8	5/8 - 3/4	6	RB	27	418	Light Champion	108154	18.95	6.00	4.19	6.81	1.56	13.55	1.31	2.41
8	5/8 - 3/4	8	BB	33	418	Light Champion	108225	21.01	8.12	4.19	6.81	1.56	14.54	1.31	2.41
8	5/8 - 3/4	8	RB	33	418	Light Champion	108252	21.01	8.12	4.19	6.81	1.56	14.54	1.31	2.41
8	5/8 - 3/4	10	BB	41	418	Light Champion	108323	23.08	10.12	4.19	6.81	1.56	15.61	1.31	2.41
8	5/8 - 3/4	10	RB	41	418	Light Champion	108350	23.08	10.12	4.19	6.81	1.56	15.61	1.31	2.41
8	5/8 - 3/4	12	BB	48	418	Light Champion	108421	25.89	12.12	4.16	6.81	1.56	17.42	1.31	2.41
8	5/8 - 3/4	12	RB	48	418	Light Champion	108458	25.89	12.12	4.16	6.81	1.56	17.42	1.31	2.41
8	5/8 - 3/4	14	BB	55	418	Light Champion	108528	27.39	14.12	4.19	6.81	1.56	17.92	1.31	2.41
8	5/8 - 3/4	14	RB	55	418	Light Champion	108546	27.39	14.12	4.19	6.81	1.56	17.92	1.31	2.41
12 tonnes															
12**	5/8 - 3/4	5.75	BB	29	L-160	Lebus, Heavy Duty	599560	19.99	6.00	4.19	7.88	1.56	14.37	1.44	2.62
12**	5/8 - 3/4	5.75	RB	29	L-160	Lebus, Heavy Duty	599579	19.99	6.00	4.19	7.88	1.56	14.37	1.44	2.62
12	3/4 - 7/8	6	BB	26	416	All Alloy	193427	19.89	6.00	4.19	7.88	1.56	14.27	1.44	2.62
12	3/4 - 7/8	6	RB	26	416	All Alloy	193472	19.89	6.00	4.19	7.88	1.56	14.27	1.44	2.62
12	3/4 - 7/8	8	BB	33	416	All Alloy	193490	21.95	8.12	4.19	7.88	1.56	15.27	1.44	2.62
12	3/4 - 7/8	8	RB	33	416	All Alloy	193542	21.95	8.12	4.19	7.88	1.56	15.27	1.44	2.62
12	3/4 - 7/8	10	BB	41	416	All Alloy	193613	24.02	10.12	4.19	7.88	1.56	16.34	1.44	2.62
12	3/4 - 7/8	10	RB	41	416	All Alloy	193677	24.02	10.12	4.19	7.88	1.56	16.34	1.44	2.62

\* Ultimate Load is 4 times the Working Load Limit. \*\* Ultimate Load is 3.5 times the Working Load Limit. ‡ Special Dual Groove Sheave also accepts 1-1/4" Manilla Rope



**HOOK FITTING,  
SINGLE SHEAVE, 15-30t**

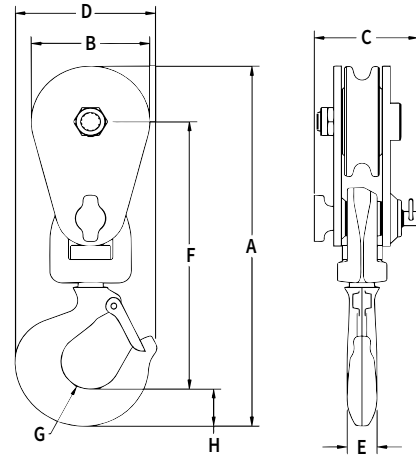

- Opening feature permits easy insertion of rope without reeving, or while the block is suspended.
- Bolt for opening feature is retained, to ensure no lost bolts.
- Forged steel swivel tees, yokes and hooks.
- Furnished with a latch installed.
- Can be furnished with bronze bushings or roller bearings.
- Center pin equipped with pressure lube fitting.
- All sizes feature sheave grooves suited for a range of wire line diameters.
- Meets or exceeds all requirements of ASME B30.26 including identification

- ductility, design factor, proof load and temperature requirements. Importantly, these blocks meet other critical performance requirements including fatigue life and material traceability, not addressed by ASME B30.26.
- All blocks are RFID EQUIPPED.
- "All Alloy" snatch blocks feature a significant reduction in weight compared to snatch blocks made of non-alloy materials.
- Crosby's Engineered Solutions Group is ready to discuss your requirements and help select or develop the ideal block for your application. Call us at 1-800-777-1555.

Working Load Limit (t)*	Wire Rope Size (in)	Sheave Diameter (in)	Bearing Code	Weight Each (lb)	Catalog No.	Description	Stock No.	Dimensions (in)							
								A	B	C	D	E	F	G	H
15 tonnes															
15	3/4 - 7/8	8	BB	51	420	Champion	108275	23.50	8.12	5.09	8.34	1.76	16.51	1.50	2.93
15	3/4 - 7/8	8	RB	51	420	Champion	108276	23.50	8.12	5.09	8.34	1.76	16.51	1.50	2.93
15	3/4 - 7/8	10	BB	63	420	Champion	108371	25.25	10.12	5.09	8.34	1.76	17.26	1.50	2.93
15	3/4 - 7/8	10	RB	63	420	Champion	108372	25.25	10.12	5.09	8.34	1.76	17.26	1.50	2.93
15	3/4 - 7/8	16	BB	130	418	Light Champion	108608	32.25	16.12	5.09	8.34	1.76	21.26	1.50	2.93
15	3/4 - 7/8	16	RB	130	418	Light Champion	108626	32.25	16.12	5.09	8.34	1.76	21.26	1.50	2.93
15	7/8 - 1	18	BB	150	418	Light Champion	108644	33.50	18.12	5.09	8.34	1.76	21.51	1.50	2.93
15	7/8 - 1	18	RB	150	418	Light Champion	108662	33.50	18.12	5.09	8.34	1.76	21.51	1.50	2.93
20 tonnes															
20	1 - 1-1/8	8	BB	75	430	Super Champion	120023	25.87	8.12	6.00	9.39	2.00	18.43	1.50	3.38
20	1 - 1-1/8	8	RB	75	430	Super Champion	120041	25.87	8.12	6.00	9.39	2.00	18.43	1.50	3.38
20	1 - 1-1/8	10	BB	89	430	Super Champion	120096	27.94	10.12	6.00	9.39	2.00	19.50	1.50	3.38
20	1 - 1-1/8	10	RB	89	430	Super Champion	120112	27.94	10.12	6.00	9.39	2.00	19.50	1.50	3.38
20	1 - 1-1/8	12	BB	103	430	Super Champion	120176	30.00	12.25	6.00	9.39	2.00	20.50	1.50	3.38
20	1 - 1-1/8	12	RB	103	430	Super Champion	120194	30.00	12.25	6.00	9.39	2.00	20.50	1.50	3.38
20	1 - 1-1/8	14	BB	123	430	Super Champion	120256	32.34	14.00	6.00	9.39	2.00	21.96	1.50	3.38
20	1 - 1-1/8	14	RB	123	430	Super Champion	120274	32.34	14.00	6.00	9.39	2.00	21.96	1.50	3.38
25 tonnes															
25	1 - 1-1/4	8	BB	90	434	All Alloy High Capacity	208896	26.56	8.25	6.13	9.36	2.00	19.06	1.50	3.38
25	1 - 1-1/4	10	BB	107	434	All Alloy High Capacity	208910	28.63	10.25	6.13	9.36	2.00	20.13	1.50	3.38
25	1 - 1-1/4	18	BB	240	430	Super Champion	119486	41.41	18.25	7.12	11.76	2.50	27.97	1.94	4.32
25	1 - 1-1/4	18	RB	240	430	Super Champion	119487	41.41	18.25	7.12	11.76	2.50	27.97	1.94	4.32
30 tonnes															
30	1 - 1-1/4	12	BB	165	434	All Alloy High Capacity	208931	36.32	12.25	7.00	11.76	2.50	25.88	1.94	4.32
30	1 - 1-1/4	14	BB	180	434	All Alloy High Capacity	208932	38.57	14.25	7.00	11.76	2.50	27.13	1.94	4.32
30	1 - 1-1/4	20	BB	375	430	Super Champion	119507	52.15	20.25	8.31	15.24	3.00	36.12	2.25	5.91
30	1 - 1-1/4	20	RB	375	430	Super Champion	119516	52.15	20.25	8.31	15.24	3.00	36.12	2.25	5.91
30	1 - 1-1/4	24	BB	450	430	Super Champion	119525	55.75	24.25	8.31	15.24	3.00	37.75	2.25	5.91
30	1 - 1-1/4	24	RB	450	430	Super Champion	119534	55.75	24.25	8.31	15.24	3.00	37.75	2.25	5.91

\* Ultimate Load is 4 times the Working Load Limit.

## TAIL BOARD, SINGLE SHEAVE, 2-12t



404



L-170



L-160



402

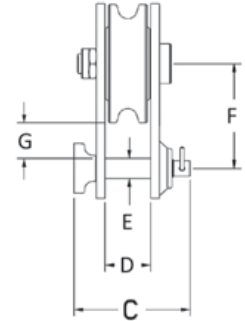
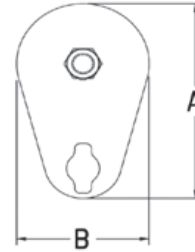

- Opening feature permits easy insertion of rope without reeving. Bolt for opening feature is retained, to ensure no lost bolts.
- Can be furnished with bronze bushings or roller bearings.
- Center pin equipped with pressure lube fitting.
- All sizes feature sheave grooves suited for a range of wire line diameters.
- Meets or exceeds all requirements of ASME B30.26 including identification ductility, design factor, proof load and temperature requirements. Importantly, these blocks meet other critical performance requirements including fatigue life and material traceability, not addressed by ASME B30.26.
- "All Alloy" snatch blocks feature a significant reduction in weight compared to snatch blocks made of non-alloy materials.
- Crosby's Engineered Solutions Group is ready to discuss your requirements and help select or develop the ideal block for your application. Call us at 1-800-777-1555.

Working Load Limit (t)*	Wire Rope Size (in)	Sheave Diameter (in)	Bearing Code	Weight Each (lb)	Catalog No.	Description	Stock No.	Dimensions (in)						
								A	B	C	D	E	F	G
2 tonnes														
2	5/16 - 3/8	3	BB	3	404	Light Champion	102016	4.87	3.00	2.64	1.04	0.50	2.62	0.87
4 tonnes														
4	3/8 - 1/2	4.5	BB	7	404	Light Champion	102025	7.75	4.25	3.13	1.56	0.75	4.25	1.63
5 tonnes														
5	3/8 - 1/2 ‡	4	BB	11	L-170	Lebus, General Purpose	599846	8.38	4.50	2.94	1.57	0.85	4.69	2.25
5	3/8 - 1/2 ‡	4	RB	11	L-170	Lebus, General Purpose	599855	8.38	4.50	2.94	1.57	0.85	4.69	2.25
6 tonnes														
6**	3/8 - 1/2	5	BB	13	L-160	Lebus, Heavy Duty	599542	8.25	5.12	3.69	1.53	0.75	4.25	1.38
6**	3/8 - 1/2	5	RB	13	L-160	Lebus, Heavy Duty	599551	8.25	5.12	3.69	1.53	0.75	4.25	1.38
8 tonnes														
8	5/8 - 3/4	6	BB	15	404	Light Champion	102098	9.87	6.00	4.19	1.80	1.00	5.12	1.62
8	5/8 - 3/4	6	RB	15	404	Light Champion	102114	9.87	6.00	4.19	1.80	1.00	5.12	1.62
8	5/8 - 3/4	8	BB	21	404	Light Champion	102169	11.93	8.12	4.19	1.80	1.00	6.12	1.62
8	5/8 - 3/4	8	RB	21	404	Light Champion	102187	11.93	8.12	4.19	1.80	1.00	6.12	1.62
8	5/8 - 3/4	10	BB	29	404	Light Champion	102230	14.00	10.12	4.19	1.80	1.00	7.19	1.69
8	5/8 - 3/4	10	RB	29	404	Light Champion	102258	14.00	10.12	4.19	1.80	1.00	7.19	1.69
8	5/8 - 3/4	12	BB	36	404	Light Champion	102301	16.81	12.12	4.19	1.80	1.00	9.00	2.50
8	5/8 - 3/4	12	RB	36	404	Light Champion	102329	16.81	12.12	4.19	1.80	1.00	9.00	2.50
12 tonnes														
12**	5/8 - 3/4	5.75	BB	29	L-160	Lebus, Heavy Duty	599604	9.97	6.00	4.19	1.72	1.00	5.22	1.85
12**	5/8 - 3/4	5.75	RB	29	L-160	Lebus, Heavy Duty	599613	9.97	6.00	4.19	1.72	1.00	5.22	1.85
12	3/4 - 7/8	6	BB	15	402	All Alloy	179238	9.87	6.00	4.19	1.80	1.00	5.12	1.62
12	3/4 - 7/8	6	RB	15	402	All Alloy	179283	9.87	6.00	4.19	1.80	1.00	5.12	1.62
12	3/4 - 7/8	8	BB	21	402	All Alloy	179318	11.93	8.12	4.19	1.80	1.00	6.12	1.62
12	3/4 - 7/8	8	RB	21	402	All Alloy	179363	11.93	8.12	4.19	1.80	1.00	6.12	1.62
12	3/4 - 7/8	10	BB	29	402	All Alloy	179434	14.00	10.12	4.19	1.80	1.00	7.19	1.69
12	3/4 - 7/8	10	RB	29	402	All Alloy	179498	14.00	10.12	4.19	1.80	1.00	7.19	1.69

\* Ultimate Load is 4 times the Working Load Limit. \*\* Ultimate Load is 3.5 times the Working Load Limit. ‡ Special Dual Groove Sheave also accepts 1-1/4" Manila Rope.

McKissick Blocks

**TAIL BOARD,  
SINGLE SHEAVE, 15-30t**



406



407



401

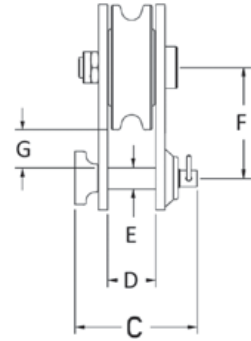
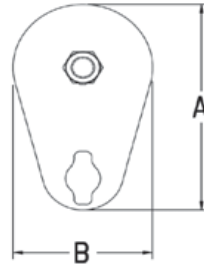

- Opening feature permits easy insertion of rope without reeving. Bolt for opening feature is retained, to ensure no lost bolts.
- Can be furnished with bronze bushings or roller bearings.
- Center pin equipped with pressure lube fitting.
- All sizes feature sheave grooves suited for a range of wire line diameters.
- Meets or exceeds all requirements of ASME B30.26 including identification ductility, design factor, proof load and temperature requirements. Importantly, these blocks meet other critical performance

- requirements including fatigue life and material traceability, not addressed by ASME B30.26.
- "All Alloy" snatch blocks feature a significant reduction in weight compared to snatch blocks made of non-alloy materials.
- Crosby's Engineered Solutions Group is ready to discuss your requirements and help select or develop the ideal block for your application. Call us at 1-800-777-1555.

Working Load Limit (t)*	Wire Rope Size (in)	Sheave Diameter (in)	Bearing Code	Weight Each (lb)	Catalog No.	Description	Stock No.	Dimensions (in)						
								A	B	C	D	E	F	G
15 tonnes														
15	3/4 - 7/8	8	BB	30	406	Champion	108311	13.19	8.12	5.13	2.35	1.25	6.75	2.13
15	3/4 - 7/8	8	RB	30	406	Champion	108312	13.19	8.12	5.13	2.35	1.25	6.75	2.13
15	3/4 - 7/8	10	BB	42	406	Champion	108406	14.94	10.12	5.13	2.35	1.25	7.50	1.94
15	3/4 - 7/8	10	RB	42	406	Champion	108407	14.94	10.12	5.13	2.35	1.25	7.50	1.94
20 tonnes														
20	1 - 1-1/8	8	BB	42	407	Super Champion	103523	13.56	8.12	6.00	2.55	1.50	7.12	2.37
20	1 - 1-1/8	8	RB	42	407	Super Champion	103541	13.56	8.12	6.00	2.55	1.50	7.12	2.37
20	1 - 1-1/8	10	BB	55	407	Super Champion	103603	15.63	10.12	6.00	2.55	1.50	8.19	2.44
20	1 - 1-1/8	10	RB	55	407	Super Champion	103621	15.63	10.12	6.00	2.55	1.50	8.19	2.44
20	1 - 1-1/8	12	BB	70	407	Super Champion	103685	17.75	12.25	6.00	2.55	1.50	9.25	2.56
20	1 - 1-1/8	12	RB	70	407	Super Champion	103701	17.75	12.25	6.00	2.55	1.50	9.25	2.56
20	1 - 1-1/8	14	BB	90	407	Super Champion	103765	20.10	14.00	6.00	2.55	1.50	10.72	2.97
20	1 - 1-1/8	14	RB	90	407	Super Champion	103783	20.10	14.00	6.00	2.55	1.50	10.72	2.97
25 tonnes														
25	1 - 1-1/4	8	BB	50	401	All Alloy High Capacity	178151	13.49	8.25	6.13	2.55	1.50	7.12	2.37
25	1 - 1-1/4	10	BB	65	401	All Alloy High Capacity	179167	15.43	10.25	6.13	2.55	1.50	8.19	2.44
25	1 - 1-1/4	18	BB	165	407	Super Champion	119652	24.62	18.25	7.12	3.05	1.75	13.00	3.13
25	1 - 1-1/4	18	RB	165	407	Super Champion	119653	24.62	18.25	7.12	3.05	1.75	13.00	3.13
30 tonnes														
30	1 - 1-1/4	12	BB	95	401	All Alloy High Capacity	179178	18.62	12.25	7.00	3.05	1.75	10.00	3.13
30	1 - 1-1/4	14	BB	110	401	All Alloy High Capacity	179187	20.88	14.25	7.00	3.05	1.75	11.25	3.38
30	1 - 1-1/4	20	BB	215	407	Super Champion	119669	28.88	20.25	8.31	3.55	2.25	15.25	4.13
30	1 - 1-1/4	20	RB	215	407	Super Champion	119678	28.88	20.25	8.31	3.55	2.25	15.25	4.13
30	1 - 1-1/4	24	BB	290	407	Super Champion	119687	32.50	24.25	8.31	3.55	2.25	16.88	3.76
30	1 - 1-1/4	24	RB	290	407	Super Champion	119696	32.50	24.25	8.31	3.55	2.25	16.88	3.76
60 tonnes														
30	1 - 1-1/4	12	BB	95	401	All Alloy High Capacity	8027292	20.32	12.12	8.66	2.78	2.50	10.75	3.50

\* Ultimate Load is 4 times the Working Load Limit.

## LIGHT CHAMPION DOUBLE SHEAVE, 4-12t



**408**  
With Hook

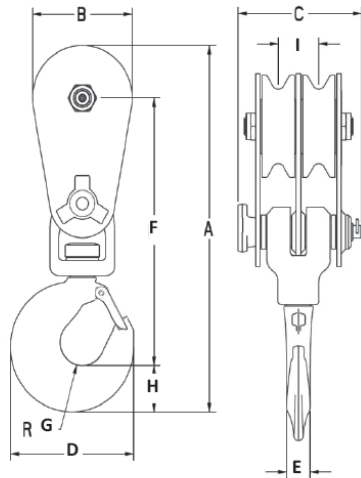

With Shackle

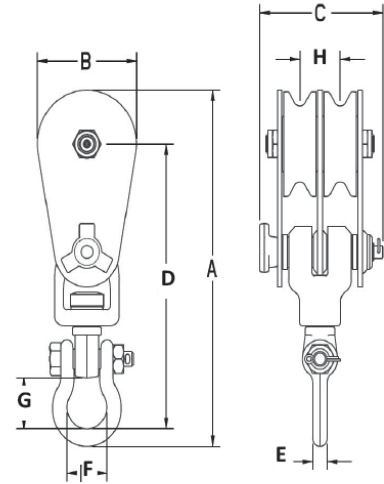

- Light champion snatch block as a double sheave block.
- Drop forged swivel hook or swivel shackle.
- Can be furnished with bronze bushings or roller bearings.
- Opening feature permits easy insertion of Wireline in both sheaves with removal of one bolt.
- 408 is furnished with S-4320 hook latch.
- Center Pin equipped with pressure lube fittings.
- All sizes feature sheave grooves suited for a range of wire line diameters.
- Meets or exceeds all requirements of ASME B30.26 including identification, ductility, design factor, proof load and temperature requirements. Importantly, these blocks meet other critical performance requirements including fatigue life and material traceability, not addressed by ASME B30.26.
- Crosby's Engineered Solutions Group is ready to discuss your requirements and help select or develop the ideal block for your application. Call us at 1-800-777-1555.

### 408 Light Champion Double Sheave with Hook

Working Load Limit (t)*	Wire Rope Size (in)	Sheave Diameter (in)	Bearing Code	Weight Each (lb)	Catalog No.	Stock No.	Dimensions (in)									
							A	B	C	D	E	F	G	H	I	
4 tonnes																
4	3/8 - 1/2	4.5	BB	18	408	104023	14.77	4.24	5.25	5.24	1.00	10.78	0.94	1.87	1.72	
12 tonnes																
12	5/8 - 3/4	6	BB	45	408	104103	21.12	6.00	6.13	7.86	1.56	15.50	1.44	2.62	2.03	
12	5/8 - 3/4	6	RB	45	408	104121	21.12	6.00	6.13	7.86	1.56	15.50	1.44	2.62	2.03	
12	5/8 - 3/4	8	BB	53	408	104185	23.18	8.12	6.13	7.86	1.56	16.50	1.44	2.62	2.03	
12	5/8 - 3/4	8	RB	53	408	104201	23.18	8.12	6.13	7.86	1.56	16.50	1.44	2.62	2.03	

\* Ultimate Load is 4 times the Working Load Limit.

### 409 Light Champion Double Sheave with Shackle

Working Load Limit (t)*	Wire Rope Size (in)	Sheave Diameter (in)	Bearing Code	Weight Each (lb)	Catalog No.	Stock No.	Dimensions (in)								
							A	B	C	D	E	F	G	H	
4 tonnes															
4	3/8 - 1/2	4.5	BB	18	409	105022	14.03	4.24	5.25	11.22	0.62	1.70	2.01	1.72	
12 tonnes															
12	5/8 - 3/4	6	BB	50	409	105102	21.12	6.00	6.13	16.36	1.50	3.12	3.12	2.03	
12	5/8 - 3/4	6	RB	50	409	105120	21.12	6.00	6.13	16.36	1.50	3.12	3.12	2.03	
12	5/8 - 3/4	8	BB	58	409	105184	23.17	8.12	6.13	17.36	1.50	3.12	3.12	2.03	
12	5/8 - 3/4	8	RB	58	409	105200	23.17	8.12	6.13	17.36	1.50	3.12	3.12	2.03	

\* Ultimate Load is 4 times the Working Load Limit.

McKissick Blocks



# Bluetooth, Wire Rope Tensionmeter and Software Solution

## Know the load

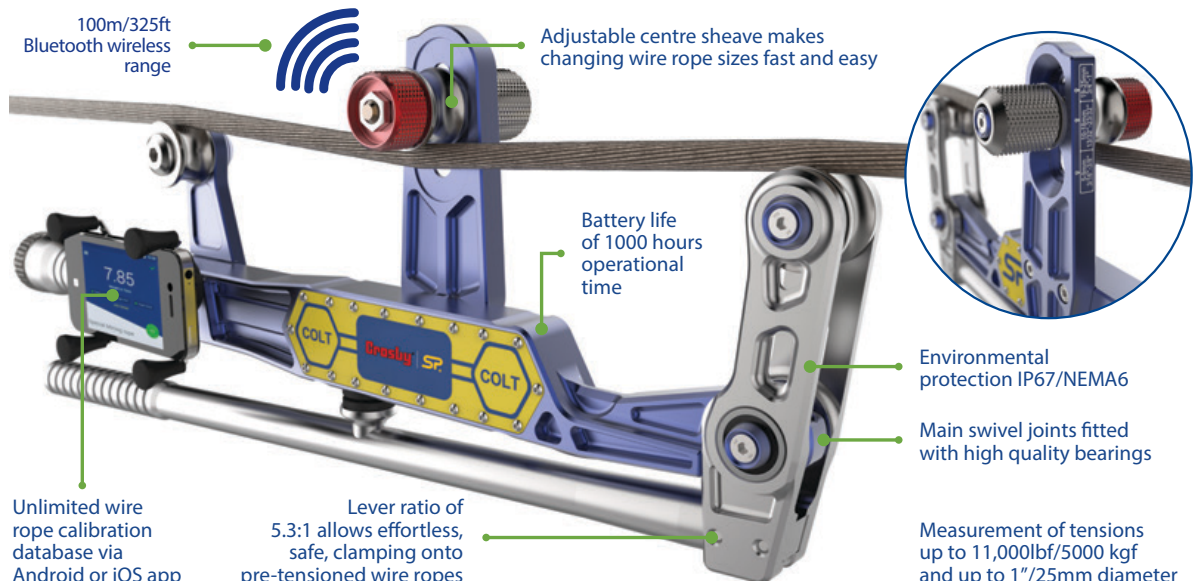

## COLT

The Straightpoint COLT is a lightweight wire rope tensionmeter for fast and accurate measurement.

- Tension reading to 5000 kg (11,000lb) wire rope up to 25mm (1 inch) diameter
- Bluetooth module transmits load data wirelessly to any smart device
- Lightweight and strong constructed from aerospace grade aluminum
- Easily operates on wires that are under tension
- Quickly check tension on wire rope set at any angle

## BlueLink

For use in new applications or replacement of outdated mechanical dynamometer devices still in use.

- Tension reading to 14,300lb (6500kg)
- Bluetooth module transmits load data wirelessly to any smart device with range of up to 328ft (100m)
- Lightweight and strong constructed from aerospace grade aluminum with safety factor of over 500%.

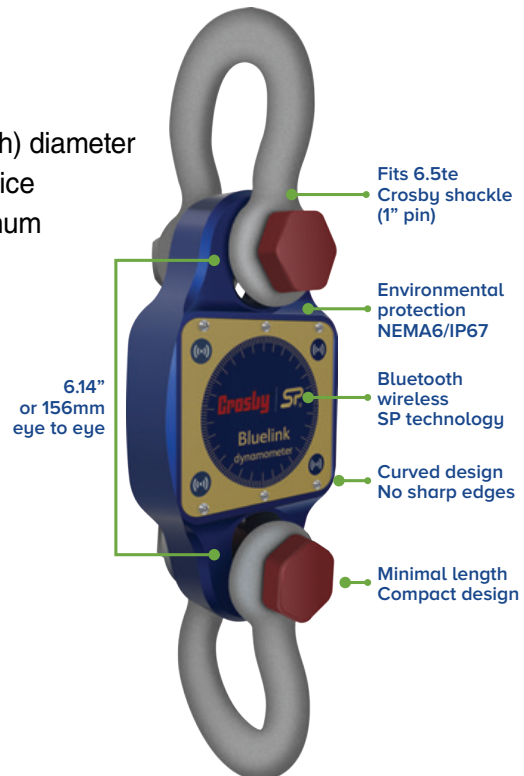



## HHP App

### SUPPLIED FREE WITH ANY SP BLUETOOTH ENABLED LOAD CELL

The HHP app allows the operator to stand back and remotely monitor the level of force being measured by your SP product in real-time, without the need for troublesome cabling.

- Connect up to 8 smart devices wirelessly to any Bluetooth enabled wireless SP device
- Operates up to 100m/328ft to provide a wider prospective of working area especially in high risk environment

## INSIGHT Software

INSIGHT software, supplied with an SW-D USB wireless dongle, connects up to 126 Straightpoint wireless load cells simultaneously onto any Windows tablet or laptop.

INSIGHT Features:

- **Multi-channel display and data logging mode** – view and log load data from connected load cells plus totals loads live on screen and directly into a .csv file for later analysis at speeds of up to 200Hz.
- **Visualization mode** – For complicated lifts import a photo of the lift and drag and drop load cell displays – make the screen look like the lift.
- **Center of gravity mode** – Connect to SP's range of wireless compression load cells and use this feature to weigh and calculate the centre of gravity of large items and structures.

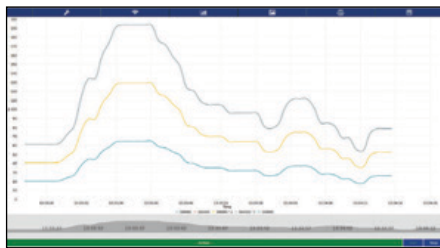

Multi-channel display mode and data logging mode



Visualization mode

Safety, reliability and quality are paramount in the lifting and rigging industries Straightpoint designs and manufactures to the highest standards including ISO9001, ATEX and DNV Type approvals.



HF-1

### Hay Fork Pulleys with Swivel Hook or Swivel Eye

- Forged steel eyes and hooks.
- Available Painted or Zinc Plated.
- One piece pressed steel shells.
- Edges well rounded to prevent chaffing of rope
- Can be furnished with SS-4320 hook latch.
- Furnished with roller bearings.
- Pressure lube fittings



HF-2

### HF-1 / HF-2 Hay Fork Pulleys with Swivel Hook or Swivel Eye

Sheave Diameter (in)	Block No.	Hay Fork Pulleys Stock No.		Working Load Limit (Tons)*	Standard Rope Size (in)	End Fitting	Weight Each (lb)
		Painted	Zinc Plated				
4-1/2	HF-1	170022	170594	1	1-1/4 MR	Swivel Hook	6
4-1/2	HF-2	170086	170629	1	1-1/4 MR	Swivel Eye	6
4-1/2	HF-3	170148	170656	1	1/2 WL	Swivel Hook	6
4-1/2	HF-4	170200	170683	1	1/2 WL	Swivel Eye	6
8	HF-5	170264	-	2	1/2 WL	Swivel Eye	11
6	HF-11	170380	-	2	1-1/2 MR	Swivel Hook	11
6	HF-12	170442	-	2	1-1/2 MR	Swivel Eye	11
6	HF-13	170503	-	2	5/8 WL	Swivel Hook	11
6	HF-14	170567	-	2	5/8 WL	Swivel Eye	11

\* Ultimate Load is 4 times the Working Load Limit. Rope Code: MR - Manila Rope, WL - Wireline.



171  
Tong Block

- Steel sheaves with roller bearings and pressure lubrication.
- Forged steel eyes and hooks.
- Easy opening feature shown available in 8" size only.



### 171 Tong Block

Sheave Diameter (in)	Block No.	171 Stock No.	Working Load Limit (Tons)*	Wireline Size (in)	Weight Each (lb)	Connection
6	TB-1	171012	1/2	3/4	11	Swivel Eye
8	TB-1	171058	1	3/4	12	Swivel Eye
10	TB-1	171101	2-1/2	3/4	30	Swivel Eye
12	TB-1	171156	2-1/2	3/4	35	Swivel Eye

\* Ultimate Load is 4 times the Working Load Limit.



443  
Lay Down Block

- All steel construction, steel sheaves mounted on antifriction bearings, grooved for maximum of 3/4" Wireline.
- Used to lay down drill pipe.
- Hook made to fit into end of drill pipe, handy dead end becket for returning block – hooks have handle for disengagement.

### 443 Lay Down Block

Sheave Diameter (in)	Block No.	443 Stock No.	Working Load Limit (Tons)*	Wireline Size (in)	Weight Each (lb)	Type Block
4-1/2	443	171414	1/4	1/2	12	Regular
6	443	171432	1/2	3/4	17	Regular

\* Ultimate Load is 4 times the Working Load Limit.

# McKissick® Oilfield Servicing Blocks



**M-491**  
Tower Hoist Block

**New design provides the dependability of standard McKissick® Snatch Blocks, along with features that make it perfect for the challenging needs of Tugger Hoist and Tower Erection applications.**

- A wide variety of configurations
  - 4, 8, 12, 15, 25 or 30 metric ton capacity
  - 3/8", 7/16", 1/2", 9/16", 5/8", 7/8", 1", 1-1/8 and 1-1/4" Wireline sizes
  - Painted or Galvanized fins
- All sizes are furnished with dual rated Wireline sheaves.
- Forged steel swivels, tees, yokes and shackles are Quenched & Tempered.
- Sheave lubrication through center pin for easy maintenance.
- Design factor of 4:1.
- All blocks 14" and larger are furnished with McKissick® Roll Forged sheaves with flame hardened grooves.
- Recessed sideplate design reduces the gap between the sheave rim and the sideplate, allowing the sheave assembly to be captured in the block if loss of center pin occurs.
- Sealed tapered roller bearings extend the life of the center pin and bearings, and allows for faster line speeds than recommended with standard snatch blocks.
- Shackle fitting swivels for easy positioning
- Suitable for hoisting personnel, contingent upon all employees, including the winch operator, being trained to follow applicable Federal, local and industry standards.
  - Tugger/Derrick applications: API RP54
  - Tower applications: OSHA directive CPL 2-1.36
- Holes through side plates are available for secondary block securement device.
- Manufactured by an API Q1 Certified facility .
- Type Approval in accordance with ABS 2015 Steel Vessel Rules.
- All sizes are **RFID EQUIPPED**.



**M-491G**  
Derrick Hoist Block



## M-491 / M-491G Tower/Derrick Hoist Blocks

Working Load Limit (t)*	Sheave Diameter (in)	Wireline Size (in)	M-491 Stock No. Painted	G-491 Stock No. Galvanized	Weight Each (lb)
4	8	3/8 - 1/2	2020161	2020170	35
8	10	3/8 - 1/2	2020806	2020815	55
8	10	1/2 - 9/16	2020824	2020833	55
12	10	1/2 - 9/16	2021118	2021127	55
12	14	1/2 - 5/8	2021136	2021145	95
12	14	5/8 - 3/4	2021154	2021163	95
15	16	3/4 - 7/8	2021172	2021181	150
15	16	7/8 - 1	2021190	2021199	150
25	18	1 - 1 1/8	2032312	2032315	260
30	20	1 1/8 - 1 1/4	2032321	2032324	675

\* Ultimate Load is 4 times the Working Load Limit.

Contact our Block Hotline, (1-800-727-1555) for larger capacity blocks up to 350 Tons or reference the special request form on page 461.





**70 Series**  
Blocks

**McKissick® Oilfield Tubing Blocks utilizing new Split Nut Retention System. Revolutionary new retention system eliminates conventional threaded nut and potential problems associated with thread corrosion.**

- Exclusive E-Z opening guards, no bolts to pull out and lose. Feature gives fastest possible exposure of sheave cluster for quick reeving.
- Extremely short overall length, extra weight, excellent balance for fast non-wobbling falls.
- Roller thrust bearing in hook.
- Duplex hook for easy elevator operation, locks in eight positions.
- Also available with Rod Hook Clevis.
- Completely streamlined, no projections.
- McKissick Roll-Forged, flame hardened sheaves, grooved to API profile for proper Wireline size. Contact Crosby for additional Wireline sizes.
- Separate lubrication channel to each sheave.
- Double row, pre-adjusted tapered bearings with seals.
- McKissick Split-Nut® hook parts precision machined and individually fitted for maximum performance.
- Manufactured to API-8C specifications
- 35 ton Capacity Rod Hook Clevis available.
- Lock Arms with Self Retaining Bolts.
- All sizes are **RFID EQUIPPED**.
- The 70 Series has a spring loaded hook that is better for heavy usage and larger depths. Tends to last longer since the shock loads are somewhat absorbed.
- The 80 Series has no spring loaded hook and is better for shallow depths and rework.



**80 Series**  
Blocks



**Fatigue Rated**



## 70 Series Tubing Blocks

Stock No.	Block Config.*	Working Load Limit (Tons)	Rod Hook Clevis Working Load Limit (Tons)	Wireline Size (in)	Weight Each (lb)
111895	20" 73-A**	75	12.5	7/8	2290
111823	24" 73	100	20	1	2634
111921	24" 73-A**	100	20	1	2750
111922	24" 73-AN**	125	35	1	2784
128798	30" 74	150	22.5	1-1/8	4488
125550	30" 74-A**	150	22.5	1-1/8	4800
112552	30" 74-AN**	175	35	1-1/8	5018

\* Spring loaded duplex hook assuring ample travel for efficient tubing operations. No load carrying threads \*\* A = Rod Hook Clevis attachment standard. AN = New 35 Ton Clevis.

## 80 Series Tubing Blocks

Stock No.	Block Config.	Working Load Limit (Tons)	Rod Hook Clevis Working Load Limit (Tons)	Wireline Size (in)	Weight Each (lb)
112135	17" 83	50	7.5	7/8	1082
112243	17" 83-A**	50	7.5	7/8	1270
112252	20" 82-A**	50	7.5	7/8	1243
112261	20" 83-A**	75	12.5	7/8	1659
112270	24" 82-A**	75	12.5	1	1830
112181	24" 83	100	20	1	2200
112279	24" 83-A**	100	20	1	2185
117498	24" 84-A**	100	20	1	2750
112278	24" 83-AN**	125	35	1	2196
117500	24" 84-AN**	125	35	1	2931
117514	30" 84-A**	150	22.5	1-1/8	4130
205857	30" 83-AN**	175	35	1-1/8	3757
117516	30" 84-AN**	175	35	1-1/8	4327

\*\* A = Rod Hook Clevis attachment standard. AN = New 35 Ton Clevis.

## WELL LOGGER'S BLOCKS



**475**  
Floor Block



**477**  
Floor Block



**476**  
Top Block

- Alloy aluminum housing for maximum strength and minimum weight.
- Conductor cable ONLY is recommended for use with Well Logger's Blocks.
- For use in high speed well logging, perforating, etc.
- Extra large double row, pre-adjusted sealed tapered bearing.
- Quick opening pin for fast string-up, light weight for easy handling.



### 475 / 477 Floor Blocks

Sheave Diam. (in)	Block No.	Floor Block Stock No.	Working Load Limit (Tons)*	Conductor Cable Size (in)†	Weight Each (lb)	Connection
7	475	180020	1-1/2	3/16	10	Swivel Hanger
10	475	180253	2-1/2	5/16	21	Swivel Hanger
12	475	180440	2-1/2	5/16	24	Swivel Hanger
14	475	180618	2-1/2	5/16	43	Swivel Hanger
14	477	169784	6	1/4	58	Swivel Clevis
20	477	191072	6	1/4	70	Swivel Clevis
24	477	191107	10	5/16	130	Swivel Clevis

\* Ultimate Load is 4 times the Working Load Limit.

† Other cable sizes available upon request.

### 476 Top Blocks

Sheave Diam. (in)	Block No.	Top Block Stock No.	Working Load Limit (Tons)*	Conductor Cable Size (in)	Weight Each (lb)	Connection
7	476	180075	2-1/2	3/16	10	Stinger Pin
10	476	180333	4	5/16	21	Stinger Pin
12	476	180529	4	5/16	24	Stinger Pin
14	476	180707	4	5/16	43	Stinger Pin

\* Ultimate Load is 4 times the Working Load Limit.



**731**  
Crown Block

## Crown Blocks

- McKissick Roll-Forged sheaves with flame hardened grooves
- Double row pre-adjusted sealed tapered bearings mounted on a steel shaft.
- Heavy center and side plates for proper support of center pin.
- Pre-assembled units for rapid attachment to crown assembly for installation on derrick.
- On multiple sheave assemblies, one sheave can be grooved for sand line on request.
- Other sizes available upon request.
- Sheaves manufactured to API-8C specifications



## Crown Blocks

Sheave Diam. (in)	Block No.	Crown Block Stock No.	No. of Sheaves	Working Load Limit (Tons)	Standard Wireline Size (in)*	Weight Each (lb)
24	241	351158	1	15	7/8	200
24	242	351167	2	30	7/8	278
24	243	351176	3	45	7/8	375
24	731	351185	1	35	1	200
24	732	351194	2	75	1	350
24	733	351201	3	100	1	525
24	734	351210	4	125	1	720
30	741	351229	1	40	1-1/8	325
30	742	351238	2	80	1-1/8	560
30	743	351247	3	110	1-1/8	800
30	744	351256	4	140	1-1/8	982
30	745	351265	5	170	1-1/8	1163

\* May be furnished in other Wireline sizes.



## API 2C Block Systems

Block Systems for Offshore pedestal mounted cranes certified to API 2C are considered critical components. McKissick provides blocks, overhaul balls, sheaves and wedge sockets that meet the critical component requirements of API 2C to required CV value. (It is the responsibility of the crane manufacturer to license or certify these components.)



Reference page 462 assist in proper specification



**RJ Style**  
Drilling Block

## RJ Style Drilling Blocks

- Capacities Available: 150, 250 & 350 Tons.
- Double row, pre-adjusted tapered bearings with seals.
- Blocks contain McKissick® Roll-Forged sheaves with flame hardened grooves.
  - Grooves are API profil
- Separate lubrication channel to each sheave.
- Easy opening guards for quick string-up (no bolts to pull out and lose).
- Each hook block is fitted with position lock and swivel lock assemblies
- Additional weights available upon request.
- Manufactured to the requirements of API 8C, including all documentation.
  - Each block is individually serialized for full traceability.
  - Furnished with Certificate of Conformance
- Hook is spring loaded with hydraulic snubber.
- Minimum design temperature of -20°C (-4°F).
- Standard top coat finish is safety orange enamel
  - Other paint colors and systems are available on request.
  - Individual parts are primer coated on exposed surfaces.
- Combination hook blocks have interchangeable parts with BJ type McKissick® blocks built up to 1982.
  - Contact Crosby Customer Service for details.
- All sizes are **RFID EQUIPPED**.

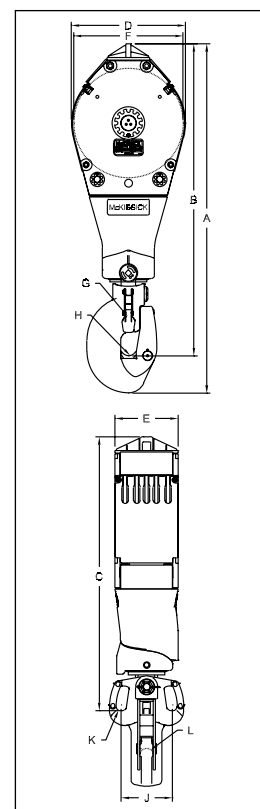

Licensed Under  
API Spec 8C-0021



## RJ Style Drilling Blocks

Model No.	RJ Block Stock No.	Working Load Limit (Tons)	Sheave Diameter (in)	No. of Sheaves	Standard Wire Rope Size (in)*	Dimensions (in)											Weight Each (lb)
						A	B	C	D	E	F	G	H	J	K	L	
864	2028185	150	30	4	1-1/8	117.03	103.52	89.03	32.50	20.25	30.00	2.38	3.00	20.00	2.00	4.25	6,490
865	2028194	150	36	4	1-1/8	121.62	108.12	93.62	38.50	22.00	36.00	2.38	3.00	20.00	2.00	4.25	8,460
866	2028203	150	36	5	1-1/8	121.62	108.12	93.62	38.50	26.75	36.00	2.38	3.00	20.00	2.00	4.25	9,650
868	2024318	250	36	5	1-1/8	129.44	115.19	100.56	38.00	24.25	36.00	3.75	3.25	19.75	1.88	4.00	10,500
869	2024317	250	42	5	1-1/8	135.44	121.19	106.56	44.00	24.25	42.00	3.75	3.25	19.75	1.88	4.00	11,000
870	2024301	350	42	5	1-1/4	147.50	132.50	113.50	44.00	24.25	42.00	3.75	3.25	22.00	2.50	4.00	12,700

\* Additional Wireline sizes are available.

McKissick  
Blocks





**RP Style**  
Traveling  
Block

### RP Style Traveling Blocks

- Capacities Available: 250, 350, 500, 750 and 1000 Tons
- Double row, pre-adjusted tapered bearings with seals.
- Blocks contain McKissick® Roll-Forged sheaves with flame hardened grooves.
  - Grooves are API profile
- Separate lubrication channel to each sheave.
- Bail design to adapt to comparable capacity drilling equipment.
- Additional weights available upon request.
- Manufactured to the requirements of API 8C, including all documentation.
  - Each block is individually serialized for full traceability.
  - Furnished with Certificate of Conformance
- Minimum design temperature of -20°C (-4°F)..
- Standard top coat finish is safety orange enamel
  - Other paint colors and systems are available on request.
  - Individual parts are primer coated on exposed surfaces.
- Block side plates can be drilled to adapt customer supplied equipment.
- Easy bail pin removal.
- All sizes are **RFID EQUIPPED**.

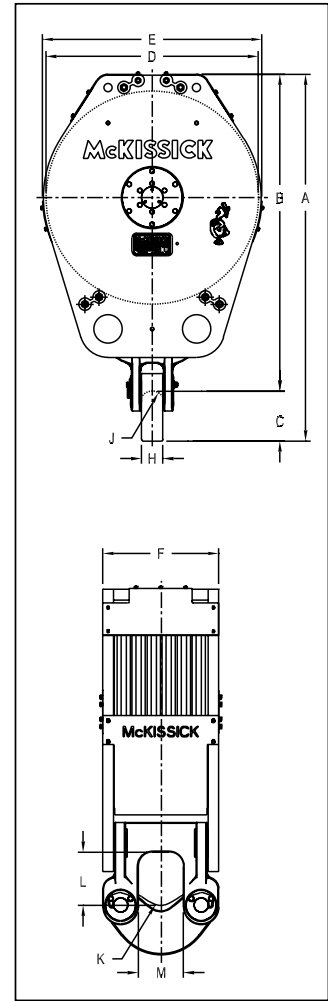

### RP Style Traveling Blocks

RP Block Stock No.	Working Load Limit (Tons)	Sheave Diam. (in)	No. of Sheaves	Standard Wireline Size (in)*	Dimensions (in)											Weight Each (lb)
					A	B	C	D	E	F	H	J	K	L	M	
2031027	250	36	5	1-1/4	74.00	63.00	11.00	36.00	39.00	24.25	5.00	2.50	3.50	10.88	7.94	5,600
2032319	250	42	5	1-1/8	80.00	69.00	11.00	42.00	44.00	24.25	5.00	2.50	3.50	10.88	7.94	7,050
2029783	350	42	5	1-1/4	80.00	69.00	11.00	42.00	44.00	24.25	5.00	2.50	3.50	10.88	7.94	7,150
2031434	350	42	6	1-1/4	80.00	69.00	11.00	42.00	44.00	28.00	5.00	2.50	3.50	10.88	7.94	7,800
2029735	500	60	6	1-3/8	98.25	84.25	14.00	60.00	61.50	32.75	6.00	3.50	4.00	15.00	12.75	16,100
2029761	750	60	7	1-1/2	107.25	92.25	15.00	60.00	61.50	39.00	9.00	4.50	5.00	18.50	17.00	21,800
2032326	1000	72	8	1-3/4	127.25	109.25	18.00	72.00	74.00	48.25	9.00	5.00	6.25	19.75	21.25	38,500

\* Additional Wireline sizes are available.



**458**  
Guy Line  
Block

## Guy Line Blocks

- Used on guy lines to gain mechanical advantage through rapid take-up, taking less pull to guy down.
- Laser burned steel side plates, cold-finished steel pins, 6" steel sheaves.



**459**  
Guy Line  
Block



## Guy Line Blocks

Block No.	No. of Sheaves	Stock No.	Working Load Limit (Tons)	Sheave Diameter (in)	Standard Wireline Size (in)*	Weight Each (lb)
458	1	171619	5	6	1/2	21
458H	1	239067	8	6	9/16 - 5/8	25
459	2	171637	10	6	1/2	28
459H	2	239076	12	6	9/16 - 5/8	31

\* May be furnished in other Wireline sizes.



**TGRB**  
Tubing Grab

**TGRB Tubing Grab**

- Designed to lift tubing from horizontal to vertical and back.
- Engages with upset end of tubing.
- Available in two sizes:
  - 2 3/8" tubing
  - 2 7/8" tubing
- Repair kit (8037937) includes springs and retaining clip.
- Fitted with 3/8" G-2130 Crosby Shackle for attachment to air tugger line.
- Secondary eye provided for attachment of tag line.
- Individually proof tested to 125% Working Load Limit.
- Standard finish is zinc plated
- **RFID Equipped.**
- Patented.

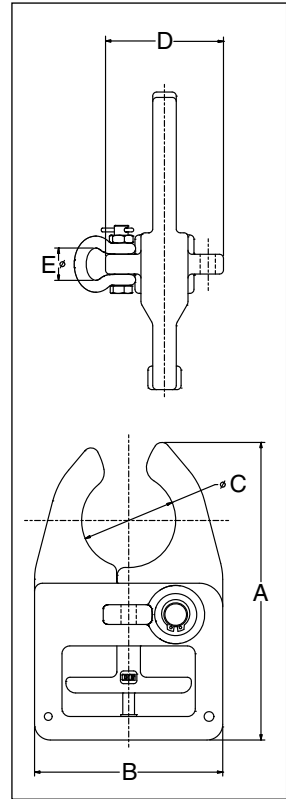

Scan this QR code with your smart device to view our product brochure.



**TGRB Tubing Grab**

Size (in)	TGRB Stock No.	Working Load Limit* (lb)	Dimensions (in)					Weight Each (lb)
			A	B	C	D	E	
2 3/8	2734950	500	9.50	6.00	2.50	3.76	1.03	11
2 7/8	2734949	500	9.50	6.00	3.00	3.76	1.03	11

\* 10:1 design factor.



# Split-Nut® Retention System

*Innovative Split-Nut design provides many benefits to selected blocks*

- ✓ Eliminates conventional threaded nut and problems associated with nut removal for inspection.
- ✓ Allows for easy inspection as required by API RP-8B and specific crane standards.
- ✓ Allows repeated installation and removal without risk of damage to hook/nut interface.
- ✓ Redundant secured and sealed fasteners (Tubing block version).
- ✓ Can be purchased in a variety of configurations that can be used to retro-fit selected McKissick® blocks – in the field or in the shop.
  - Hook and nut assembly that fits existing 80 Series cases.
  - Hook and case assembly that bolts into existing block.
  - Hook and Trunnion assembly that replaces existing hook and trunnion in crane blocks.
- ✓ Fatigue Rated

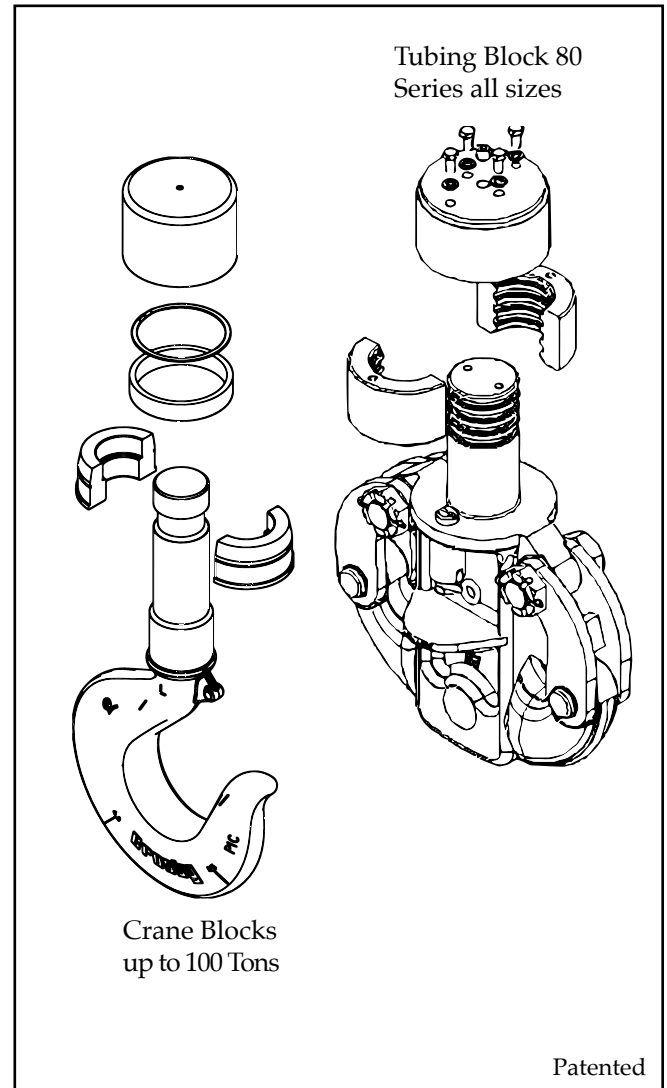

**Fatigue Rated**



Licensed Under  
API Spec 8C-0021

**Crosby**®

(918) 834-4611  
[www.thecrosbygroup.com](http://www.thecrosbygroup.com)  
[crosbygroup@thecrosbygroup.com](mailto:crosbygroup@thecrosbygroup.com)



**T**hese seminar and support materials were developed for the Crosby product line. The materials are intended to be used as classroom references in training sessions conducted by Authorized Crosby Instructors. Crosby provides instruction only on how to use the material. Crosby does not select or determine whether each attendee is qualified to be a trainer. The management of companies requesting the Crosby training is responsible for determining the capability and suitability of all trainers in their employment.

## API RP-2D Rigging Training Development Course (For Offshore Environments)

**Those who attend Day One, Course #OE-001 will receive:**

- Certificate of Completion
- A Crosby Workbook API RP-2D
- Crosby's API Users Guide for Lifting laminated pocket reference guide

**Those who attend the full two-day program, Course #OE-003, will receive:**

- Same materials as shown above, plus:
- Crosby General Catalog on DVD
- Crosby API CD Lift Guide (Computer Based Course)
- The ability to receive a "Crosby Authorized Trainer" certificate valid for four year
- A CD with PowerPoint files for a 4-to 7-hour rigging presentation
- The ability to order Crosby training materials at reduced prices
- Can earn "CEU" credits



## Land Based Energy Operations Rigging Training Development Course

**Those who attend Day One, Course #LB-001 will receive:**

- Certificate of Completion
- A Crosby Seminar Workbook: Land Based Energy Operations, Edition 1
- Crosby's Land-Based Users Guide for Lifting laminated pocket reference guide

**Those who attend the full two-day program, Course #LB-001 and #LB-003, will receive:**

- Same materials as shown above, plus:
- Crosby General Catalog on DVD
- Crosby CD Lift Guide (Computer Based Course)
- The ability to receive a "Crosby Authorized Trainer" certificate valid for four year
- A CD with PowerPoint files for a 7-to 9-hour rigging presentation
- The ability to order Crosby training materials at reduced prices
- Can earn "CEU" credits



## ASME/OSHA Rigging Training Development Course

**Those who attend day one, Course CA-005 will receive:**

- Certificate of Completion
- A Crosby Rigging Workbook : Edition 7 Trainers Workbook
- Crosby ASME Users Guide for Lifting laminated pocket reference guide

**Those who attend the full two day program, Course CA-005 and CA-006**

- Same materials as shown above, plus:
- Crosby General Catalog on DVD
- Crosby CD Lift Guide (Computer Based Course)
- Crosby / McKissick Block Selection and Application DVD
- Crosby IP Clamps Selection and Application DVD
- A CD with PowerPoint files for a 4 to 7 hour rigging presentation
- The ability to receive a "Crosby Authorized Trainer" certificate valid for four year
- A CD-Rom with PowerPoint files for a 7-to 9-hour rigging presentation
- The ability to order Crosby training materials at reduced prices
- Can earn "CEU" credits



Classroom training is only a small part of the needed qualifications. Demonstrated ability on the job is equally important. Once the certificate request form is signed by a supervisor or manager and all requirements are met, we will send a certificate authorizing you to use Crosby training materials for 48 months

# TACKLE BLOCK & SHEAVE ASSEMBLY

## WARNINGS, USE AND MAINTENANCE INFORMATION

### WARNING

- A potential hazard exists when lifting or dragging heavy loads with tackle block assemblies.
- Failure to design and use tackle block systems properly may cause a load to slip or fall – the result could be serious injury or death.
- Failure to design lifting system with appropriate sheave assembly material for the intended application may cause premature sheave, bearing or Wireline wear and ultimate failure - the result could be serious injury or death.
- A tackle block system should be rigged by a qualified person as defined by ANSI/ASME B30.26.
- Instruct workers to keep hands and body away from block sheaves and swivels – and away from “pinch points” where rope touches block parts or loads.
- Do not side load tackle blocks.
- See OSHA Rule 1926.1431(g)(1)(i)(A) and 1926.1501(g)(4)(iv)(B) for personnel hoisting by cranes and derricks, and OSHA Directive CPL 2-1.36 — Interim Inspection Procedures During Communication Tower Construction Activities. Only a Crosby or McKissick Hook with a PL latch attached and secured with a bolt, nut and cotter pin (or toggle pin) or a PL-N latch attached and secured with toggle pin; or a Crosby hook with an S-4320 latch attached and secured with cotter pin or bolt, nut and pin; or a Crosby SHUR-LOC® Hook in the locked position may be used for any personnel hoisting. A hook with a Crosby SS-4055 latch attached shall NOT be used for personnel lifting.
- Instruct workers to be alert and to wear proper safety gear in areas where loads are moved or supported with tackle block systems.
- Use only genuine Crosby parts as replacement.
- Read, understand, and follow these instructions to select, use and maintain tackle block systems.
- Do not use a block or ball that does not have a legible capacity tag.

### Important:

For maximum safety and efficiency, tackle block and sheave systems must be properly designed, used, and maintained. You must understand the use of tackle block components and sheaves in the system. These instructions provide this knowledge. Read them carefully and completely.

Some parts of these instructions must use technical words and detailed explanations. NOTE: If you do not understand all words, diagrams, and definitions – **DO NOT TRY TO DESIGN OR USE A TACKLE BLOCK OR SHEAVE SYSTEM!** For further assistance, call:

**In U.S.A.** – Crosby Engineered Products Group  
at (800) 777-1555.

**In CANADA** – Crosby Canada, Ltd. (877) 462-7672.

**In EUROPE** – N.V. Crosby Europe (+32)(0) 15 75 71 25.

As you read instructions, pay particular attention to safety information in bold print.

**KEEP INSTRUCTIONS FOR FUTURE USE – DO NOT THROW AWAY!**

## General Cautions or Warnings

Ratings shown in Crosby Group literature are applicable only to new or in “as new” products.

Working Load Limit ratings indicate the greatest force or load a product can carry under usual environmental conditions. Shock loading and extraordinary conditions must be taken into account when selecting products for use in tackle block systems. Working Load Limit ratings are based on all sheaves of tackle block system being utilized. If all sheaves are not utilized, balance must be maintained, and the Working Load Limit must be reduced proportionally to prevent overloading sheave components. Changes from full sheave reeving arrangement should be only at the recommendation of a qualified person, and incorporate good rigging practices.

In general, the products displayed in Crosby Group literature are used as parts of a system being employed to accomplish a task. Therefore, we can only recommend within the Working Load Limits, or other stated limitations, the use of products for this purpose.

The Working Load Limit or Design (Safety) Factor of each Crosby product may be affected by wear, misuse, overloading, corrosion, deformation, intentional alteration, and other use conditions. Regular inspection must be conducted to determine whether use can be continued at the catalog assigned WLL, a reduced WLL, a reduced Design (Safety) Factor, or withdrawn from service.

Crosby Group products generally are intended for tension or pull. Side loading must be avoided, as it exerts additional force or loading which the product is not designed to accommodate.

Always make sure the hook supports the load. The latch must never support the load.

Welding of load supporting parts or products can be hazardous. Knowledge of materials, heat treatment, and welding procedures are necessary for proper welding. Crosby Group should be consulted for information.

Crane component parts, i.e., the boom, block, overhaul ball, swivel, and wire ropes are metallic and will conduct electricity. Read and understand OSHA standard covering crane and derrick operations (29 CFR 1926.1501 SUBPART N) before operating proximate to power lines.

## Definitions

**STATIC LOAD** – The load resulting from a constantly applied force or load.

**WORKING LOAD LIMIT** – The maximum mass or force which the product is authorized to support in general service when the pull is applied in-line, unless noted otherwise, with respect to the center line of the product. This term is used interchangeably with the following terms.

1. WLL
2. Rated Load Value
3. SWL
4. Safe Working Load
5. Resultant Safe Working Load

**WORKING LOAD** – The maximum mass or force which the product is authorized to support in a particular service.

**PROOF LOAD** – The average force applied in the performance of a proof test; the average force to which a product may be subjected before deformation occurs.

**PROOF TEST** – A test applied to a product solely to determine non-conforming material or manufacturing defects.

**ULTIMATE LOAD** – The average load or force at which the product fails, or no longer supports the load.

**SHOCK LOAD** – A force that results from the rapid application of a force (such as impacting and/or jerking) or rapid movement of a static load. A shock load significantly adds to the static load.

**DESIGN (SAFETY) FACTOR** – An industry term denoting a product's theoretical reserve capability, usually computed by dividing the catalog Ultimate Load by the Working Load Limit. Generally expressed for blocks as a ratio of 4:1.

**TACKLE BLOCK** – An assembly consisting of a sheave(s), side plates, and generally an end fitting (hook, shackle, etc.) that is used for lifting, lowering, or applying tension.

**SHEAVE / SHEAVE BEARING ASSEMBLY** – Purchased by O.E.M. or end user to be used in their block or lifting system design.

### Fitting Maintenance

Fittings, including hooks, overhaul balls, shackles, links, etc., may become worn and disfigured with use, corrosion, and abuse resulting in nicks, gouges, worn threads and bearings, sharp corners which may produce additional stress conditions and reduce system load capacity.

Grinding is the recommended procedure to restore smooth surfaces. The maximum allowance for reduction of a product's original dimension due to wear or repair before removal from service is:

1. Any single direction - No more than 10% of original dimension;
2. Two directions - No more than 5% of each dimension.

For detailed instructions on specific products, see the application and warning information for that product. Any greater reduction may necessitate a reduced Working Load Limit.

Any crack or deformation in a fitting is sufficient cause to withdraw the product from service.

### Selection Guide

Some of the blocks shown in Crosby Group literature are named for their intended use and selection is routine. A few examples include the "Double Rig Trawl Block" used in the fishing industry, the "Well Loggers Block" used in the oil drilling industry, and the "Cargo Hoisting Block" used in the freighter boat industry and "Derrick and Tower Block" used for hoisting personnel. Others are more generally classified and have a variety of uses. They include snatch blocks, regular wood blocks, standard steel blocks, etc. For example, snatch blocks allow the line to be attached by opening up the block instead of threading the line through the block. This feature eliminates the use of rope guards and allows various line entrance and exit angles to change direction of the load. These angles determine the load on the block and/or the block fitting. (See "Loads on Blocks.") Snatch blocks are intended for infrequent and intermittent use with slow line speeds.

A tackle block sheave assembly is one element of a system used to lift, change direction or drag a load. There are other elements in the system including the prime mover (hoist, winch, hand), supporting structure, power available, etc. All of these elements can influence the type of tackle block or sheave required. When selecting a block or sheave for the system in your specific application, you should consider the other elements as well as the features of the blocks and sheaves shown in Crosby Group literature.

To select a tackle block or sheave to fit your requirements, consider the following points:

1. Are there regulations which could affect your choice of blocks or sheaves, such as federal or state, OSHA, elevator safety, mine safety, maritime, insurance, etc.?
2. What is the weight of the load, including any dynamics of impacts that add to load value? You must know this to determine the minimum required Working Load Limit value of the block or load on sheave.
3. How many parts of line are required? This can be determined given the load to be lifted and the line pull you have available. As an alternative, you could calculate the line pull required with a given number of parts of line and a given load weight.  
(See "How to Figure Line Parts.")
4. What is the size of line to be used? Multiply the available line pull by the desired safety factor for Wireline to determine the minimum catalog Wireline breaking strength; consult a Wireline catalog for the corresponding grade and diameter of Wireline to match. You should also consider fatigue factors that affect Wireline life. (See "Sheave Size & Wireline Strength.")
5. What is the speed of the line? This will help you determine the type of sheave bearing necessary. There are several choices of bearings suitable for different applications, including:
  - A. **Common (Plain) Bore** for very slow line speeds and very infrequent use (high bearing friction).
  - B. **Self Lubricating Bronze Bushings** for slow line speeds and infrequent use (moderate bearing friction).
  - C. **Bronze Bushing** with pressure lubrication for slow line speeds and more frequent use at greater loads (moderate bearing friction).
  - D. **Anti-friction Bearings** for faster line speeds and more frequent use at greater loads (minimum bearing friction).
6. What type of fitting is required for your application? The selection may depend on whether the block will be traveling or stationary. Your choices include single or multiple hooks with or without throat latches and shackles, which are the most secured load attachment. You should also decide whether the fitting should be fixed, swivel or swivel with lock. If it is a swivel fitting, then selection of a thrust bearing may be necessary. There are plain fittings with no bearings for positioning at no load, bronze bushed fittings for infrequent and moderate load swiveling, and anti-friction bearing equipped fittings for frequent load swiveling.
7. How will the block be reeved and does it require a dead end becket? (See "The Reeving of Tackle Blocks.")
8. How will the block be reeved and does it require a dead end becket? (See "The Reeving of Tackle Blocks.")
9. If the block is to be a traveling block, what weight is required to overhaul the line? (See "How to Determine Overhaul Weights.")
10. What is the fleet angle of the Wireline? Line entrance and exit angles should be no more than 1-1/2 degrees.
11. How will the block or sheave be maintained? Do conditions in your application require special maintenance considerations? (See "Tackle Block and Sheave Maintenance," and "Fitting Maintenance.")
12. Reference current edition of "Wireline Users Manual" for additional sheave design and maintenance information.



## Tackle Block and Sheave Maintenance

Tackle Blocks and Sheaves must be regularly inspected, lubricated, and maintained for peak efficiency and extended usefulness. Their proper use and maintenance is equal in importance to other mechanical equipment. The frequency of inspection and lubrication is dependent upon frequency and periods of use, environmental conditions, and the user's good judgment.

**Inspection:** As a minimum, the following points should be considered:

1. Wear on pins or axles, rope grooves, side plates, bushing or bearings, cases, trunnions, hook shanks, and fittings (See Fitting Maintenance). Excessive wear may be a cause to replace parts or remove block or sheave from service.
2. Deformation in side plates, pins and axles, fitting attachment points, trunnions, etc. Deformation can be caused by abusive service or overload and may be a cause to remove block or sheave from service.
3. Misalignment or wobble in sheaves.
4. Security of nuts, bolts, and other locking methods, especially after reassembly following a tear down inspection. Original securing method should be used; e.g., staking, set screw, cotter pin, cap screw.
5. Pins retained by snap rings should be checked for missing or loose rings.
6. Sheave pin nuts should be checked for proper positioning. Pins for tapered roller bearings should be tightened to remove all end play during sheave rotation. Pins for bronze bushings and straight roller bearings should have a running clearance of .031 inch per sheave of end play and should be adjusted accordingly.
7. Hook or shackle to swivel case clearance is set at .031 to .062 at the factory. Increased clearance can result from component wear. Clearance exceeding .12 to .18 should necessitate disassembly and further inspection.
8. Deformation or corrosion of hook and nut threads. Your block's hook may be fitted with the Crosby/McKissick Patented Split Nut. Refer to the Split Nut section for proper removal, inspection and installation procedures.
9. Loss of material due to corrosion or wear on external area of welded hook and nut may indicate thread corrosion or damage. If these conditions exist, remove from service or perform load test.
10. Surface condition and deformation of hook (See Fitting Maintenance and ASME B30.10.)
11. Welded side plates for weld corrosion or weld cracking.
12. Hook latch for deformation, proper fit and operation.
13. Remove from service any bushings with cracks on inside diameter or bushing end. Bushings that are cracked and/or extended beyond sheave hub are indications of bushing overload.

**LUBRICATION:** The frequency of lubrication depends upon frequency and period of product use as well as environmental conditions, which are contingent upon the user's good judgment. Assuming normal product use, the following schedule is suggested when using lithium-base grease of a medium consistency.

### SHEAVE BEARINGS

**Tapered Roller Bearings** – Every 40 hours of continuous operation or every 30 days of intermittent operation.

**Roller Bearings** – Every 24 hours of continuous operation or every 14 days of intermittent operation.

**Bronze Bushings** – (Not Self Lubricated) – Every 8 hours of continuous operation or every 14 days of intermittent operation.

**Self Lubricating Bronze Bushing** – are for slow line speeds and infrequent use (moderate bearing friction). Frequent inspection is required to determine the condition of bushing.

### HOOK BEARINGS

**Anti Friction** – Every 14 days for frequent swiveling; every 45 days for infrequent swiveling.

**Bronze Thrust Bushing or No Bearing** Every 16 hours for frequent swiveling; every 21 days for infrequent swiveling.

Tackle Block Maintenance also depends upon proper block selection (see "Loads on Blocks"), proper reeving (see "The Reeving of Tackle Blocks"), consideration of shock loads, side loading, and other adverse conditions.

## Sheave Bearing Application Information

Sheaves in a system of blocks rotate at different rates of speed, and have different loads. When raising and lowering, the line tension is not equal throughout the system. Refer to Page 387 "How to Figure Line Parts" for assistance in determining lead line loads used for bushing or bearing selection.

### BRONZE BUSHINGS

Bronze Bushings are used primarily for sheave applications using slow line speed, moderate load, and moderate use. The performance capability of a bearing is related to the bearing pressure and the bearing surface velocity by a relationship known as true PV (Maximum Pressure - Velocity Factor). The material properties of the Bronze Bushings furnished as standard in Crosby catalog sheaves are:

(BP) Maximum Bearing Pressure :4500 PSI

(BV) Maximum Velocity at Bearing :1200 FPM

(PV) Maximum Pressure Velocity Factor: 55000

(It should be noted that due to material property relations, the maximum BP times the maximum BV is NOT equal to the maximum PV.)

### Formula for Calculating Bearing Pressure:

$$BP = \frac{\text{Line Pull} \times \text{Angle Factor}}{\text{Shaft Size} \times \text{Hub Width}}$$

Note: Angle Factor Multipliers listed on page 384.

### Formula for Calculating Bearing Velocity:

$$BV = \frac{PV}{BP}$$

### Formula for Calculating Line Speed:

$$\text{Line Speed} = \frac{BV (\text{Tread Diameter} + \text{Rope Diameter})}{\text{Shaft Diameter}}$$

Calculations can be made to find the maximum allowable line speed for a given total sheave load. If the required line speed is greater than the maximum allowable line speed calculated, then increase the shaft size and/or the hub width and recalculate. Continue the process until the maximum allowable line speed is equal to or exceeds the required line speed.

### Example

Using a 14 in. sheave (Stock # 917191; refer to Wireline sheave section of this Catalog for dimensions) with a 4,600 lbs. line pull and an 80° angle between lines, determine maximum allowable line speed.

$$BP = \frac{4,600 \text{ lbs.} \times 1.53}{1.50 \times 1.62} = 2,896 \text{ PSI}$$

(Line pull) (Angle Factor)  
(Shaft Size) (Hub Width)

$$BV = \frac{55,000 \text{ (PV Factor)}}{2,896 \text{ (BP)}} = 19 \text{ FPM Allowable}$$



**Line Speed =**  
 $[19 \times (11.75 + .75)] \div 1.50 = 158.3 \text{ FPM ALLOWABLE}$   
 (BV) (Tread Dia. + Rope Size) ÷ (Shaft Dia.)

**If the application required a line speed equal to 200 FPM, then another calculation would be necessary. Trying another 14 in. sheave (stock # 4104828) under the same loading conditions, the results are as follows:**

**BP =**  $(4,600 \text{ lbs.} \times 1.53) \div (2.75 \times 2.31) = 1,108 \text{ PSI}$

**BV =**  $55,000 \div 1,108 = 50 \text{ FPM}$

**Line Speed =**  
 $[50 \times (11.75 + .75)] \div 2.75 = 227.3 \text{ FPM ALLOWABLE}$

**COMMON (PLAIN) BORE –**

Very slow line speed, very infrequent use, low load.

**ROLLER BEARING –**

Faster line speeds, more frequent use, greater load. Refer to manufacturer's rating. Reference appropriate bearing manufacturer's catalog for proper bearing selection procedure.

**Loads on Blocks**

The Working Load Limit (WLL) for Crosby Group blocks indicates the maximum load that should be exerted on the block and its connecting fitting.

This total load value may be different from the weight being lifted or pulled by a hoisting or hauling system. It is necessary to determine the total load being imposed on each block in the system to properly determine the rated capacity block to be used.

A single sheave block used to change load line direction can be subjected to total loads greatly different from the weight being lifted or pulled. The total load value varies with the angle between the incoming and departing lines to the block.

The following chart indicates the factor to be multiplied by the line pull to obtain the total load on the block.

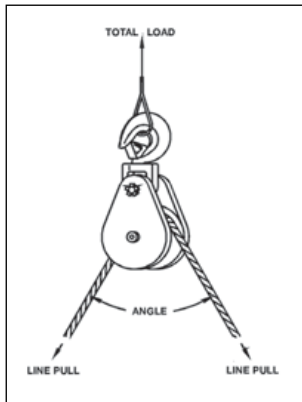

Angle Factor Multipliers			
Angle	Factor	Angle	Factor
0°	2.00	100°	1.29
10°	1.99	110°	1.15
20°	1.97	120°	1.00
30°	1.93	130°	.84
40°	1.87	135°	.76
45°	1.84	140°	.68
50°	1.81	150°	.52
60°	1.73	160°	.35
70°	1.64	170°	.17
80°	1.53	180°	.00
90°	1.41	—	—

**Example A**

(Calculations for determining total load value on single line system.)

A gin pole truck lifting 1,000 lbs.

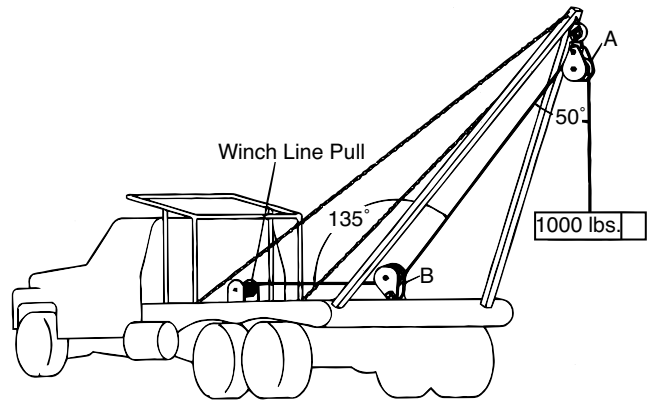

There is no mechanical advantage to a single part load line system, so winch line pull is equal to 1,000 lbs. or the weight being lifted.

To determine total load on snatch block A:

**A = 1,000 lbs. x 1.81 = 1,810 lbs.**  
 (line pull) (factor 50° angle)

To determine total load on toggle block B:

**B = 1,000 lbs. x .76 = 760 lbs.**  
 (line pull) (factor 135° angle)

**Example B**

(Calculation for determining total load value for mechanical advantage system.)

Hoisting system lifting 1,000 lb. using a traveling block. The mechanical advantage of traveling block C is 2.00 because two (2) parts of load line support the 1,000 lbs weight. (Note that this example is simplified for determination of resultant load on blocks. Lead line pull will be greater than shown due to efficiency losses.) (To determine single line pull for various bearing efficiency see "How to Figure Line Parts")

To Determine Line Pull:

**Line Pull = 1,000 lbs. ÷ 2.00 = 500 lbs.**

To determine total load on traveling block C:

**C = 500 lbs. x 2.0 = 1,000 lbs.**

(line pull)(Factor 0° angle)

To determine total load on stationary block D:

**D = 500 lbs. x 1.87 + 500 lbs. = 1,435 lbs.**

(line pull) (dead-end load)  
(Factor 40° angle)

To determine total load on block E:

**E = 500 lbs. x .84 = 420 lbs.**

(line pull) (Factor 130° angle)

To determine total load on block F:

**F = 500 lbs. x 1.41 = 705 lbs.**

(line pull) (Factor 90° angle)

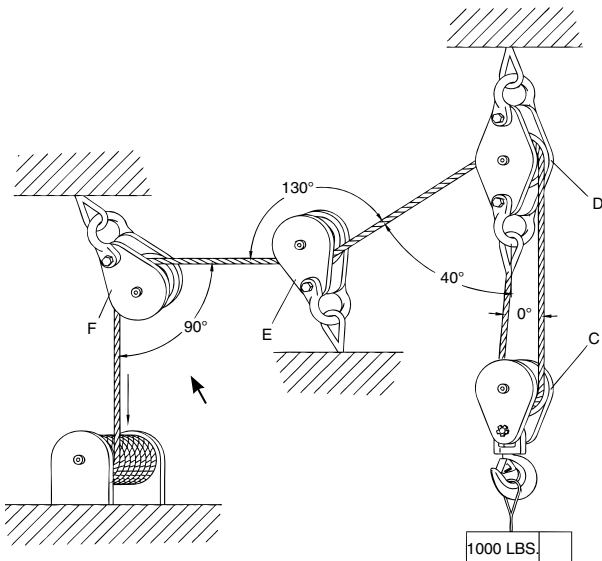

**The Reeving of Tackle Blocks**

In reeving of tackle blocks, there are many methods. The method discussed below is referred to as "Right Angle" reeving. Please consult your rigging manual for other methods of reeving.

**RIGHT ANGLE REEVING**

In reeving a pair of tackle blocks, one of which has more than two sheaves, the hoisting rope should lead from one of the center sheaves of the upper block to prevent toppling and avoid injury to the rope. The two blocks should be placed so that the sheaves in the upper block are at right angles to those in the lower one, as shown in the following illustrations.

Start reeving with the becket or dead end of the rope. **Use a shackle block as the upper one of a pair and a hook block as the lower one as seen below.** Sheaves in a set of blocks revolve at different rates of speed. Those nearest the lead line revolve at the highest rate of speed and wear out more rapidly. All sheaves should be kept well lubricated when in operation to reduce friction and wear.

**Reeving Diagram**

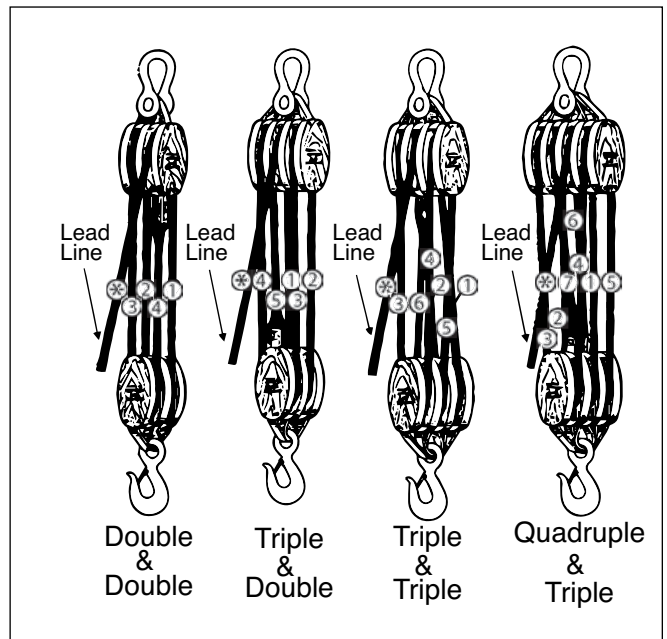

McKissick  
Blocks

**CAUTION**

- Exercise care when block is standing in vertical position, as the potential for tipping exists. Potential causes of tipping are unstable work area, boom movement and the reeving process.
- If work area is unstable, lay block flat on side plate.



## Sheave Size & Wireline Strength

### Strength Efficiency

Bending Wireline reduces its strength. To account for the effect of bend radius on Wireline strength when selecting a sheave, use the table below:

Ratio A	Strength Efficiency Compared to Catalog Strength in %
40	95
30	93
20	91
15	89
10	86
8	83
6	79
4	75
2	65
1	50

$$\text{Ratio A} = \frac{\text{Sheave Diameter}}{\text{Rope Diameter}}$$

### Example

To determine the strength efficiency of 1/2" diameter Wireline using a 10" diameter sheave:

$$\text{Ratio A} = \frac{10'' \text{ (sheave diameter)}}{1/2'' \text{ (Wireline diameter)}} = 20$$

Refer to ratio A of 20 in the table then check the column under the heading "Strength Efficiency Compared to Catalog Strength in %"...91% strength efficiency as compared to the catalog strength of Wireline.

### Fatigue Life

Repeated bending and straightening of Wireline causes a cyclic change of stress called "fatiguing." Bend radius affects Wireline fatigue life. A comparison of the relative effect of sheave diameter on Wireline fatigue life can be determined as shown below:

Ratio B	Relative Fatigue Bending Life
30	10.0
25	6.6
20	3.8
18	2.9
16	2.1
14	1.5
12	1.1

$$\text{Ratio B} = \frac{\text{Sheave Diameter}}{\text{Rope Diameter}}$$

$$\text{Relative Fatigue Bending Life} = \frac{\text{Relative Fatigue Bending Life Sheave \#1}}{\text{Relative Fatigue Bending Life (Sheave \#2)}}$$

### Example

To determine the extension of fatigue life for a 3/4" Wireline using a 22.5" diameter sheave versus a 12" diameter sheave:

$$\text{Ratio B} = \frac{22.5'' \text{ (sheave diameter)}}{3/4'' \text{ (Wireline diameter)}} = 30$$

$$\text{Ratio B} = \frac{12'' \text{ (sheave diameter)}}{3/4'' \text{ (Wireline diameter)}} = 16$$

The relative fatigue bending life for a ratio B of 16 is 2.1 (see above Table) and ratio B of 30 is 10.

$$\text{Relative Fatigue Bending Life} = \frac{10}{2.1} = 4.7$$

Therefore, we expect extension of fatigue life using a 22.5" diameter sheave to be 4.7 times greater than that of a 12" diameter sheave.

## How to Determine Overhauling Weights

To determine the weight of the block or overhaul ball that is required to free fall the block, the following information is needed: size of Wireline, number of line parts, type of sheave bearing, length of crane boom, and drum friction (use 50 lbs. unless other information is available).

Wireline Size (in)	Factor A – Wireline Weight lbs. per ft., 6 x 19 IWRC
3/8	.26
7/16	.35
1/2	.46
9/16	.59
5/8	.72
3/4	1.04
7/8	1.42
1	1.85
1-1/8	2.34
1-1/4	2.89

Number of Line Parts	Factor B – Overhaul Factors	
	Roller Bearing Sheaves	Bronze Bushed Sheaves
1	1.03	1.05
2	2.07	2.15
3	3.15	3.28
4	4.25	4.48
5	5.38	5.72
6	6.54	7.03
7	7.73	8.39
8	8.94	9.80
9	10.20	11.30
10	11.50	12.80

The Formula is:

$$\text{Required Block Weight} = [(\text{Boom Length} \times \text{Factor A}) + \text{Drum Friction}] \times \text{Factor B}$$

### Example:

To determine the required block or overhaul weight using 5 parts of 7/8" diameter Wireline, a 50 ft. boom and roller bearing sheaves:

$$\text{Required Block Weight} = [(50 \text{ ft.} \times 1.42) + 50 \text{ lbs.}] \times 5.38 = 651 \text{ lbs.}$$

(Boom Length)
(Drum Friction)
(Factor A)
(Factor B)

## How to Figure Line Parts

Sheaves in a system of blocks rotate at different rates of speed, and have different loads. When raising and lowering, the line tension is not equal throughout the system. To help figure the number of parts of line to be used for a given load, or the line pull required for a given load, (for example, use Reeving Diagram on page 385. Only numbered lines shall be used in the calculation). The following ratio table is provided with examples of how to use it. The ratios are applicable for blocks as shown on page 385 and also independent sheave systems that line is reeved through.

Ratio A Bronze Bushed Sheaves	Ratio B Anti-Friction Bearing Sheaves	Number of Line Parts
.96	.98	1
1.87	1.94	2
2.75	2.88	3
3.59	3.81	4
4.39	4.71	5
5.16	5.60	6
5.90	6.47	7
6.60	7.32	8
7.27	8.16	9
7.91	8.98	10
8.52	9.79	11
9.11	10.60	12
9.68	11.40	13
10.20	12.10	14
10.70	12.90	15
11.20	13.60	16
11.70	14.30	17
12.20	15.00	18
12.60	15.70	19
13.00	16.40	20

$$\text{Ratio A or B} = \frac{\text{Total Load to be Lifted}}{\text{Single Line Pull (lb)}}$$

After calculating Ratio A or B, consult table to determine number of parts of line.

### Examples:

To find the number of parts of line needed when weight of load and single line pull are known, and using Bronze Bushed Sheaves.

$$\text{Ratio A} = \frac{72,180 \text{ lbs. (load to be lifted)}}{8000 \text{ lbs. (single line pull)}} = 9.02 \quad (\text{Ratio A})$$

In table above refer to ratio 9.02 or next higher number, then check column under heading "Number of Line Parts" = 12 parts of line to be used for this load.

To find the single line pull needed when weight of load and number of parts of line are known, and using Anti-Friction Bearing Sheaves.

$$\text{Single Line Pull} = \frac{68,000 \text{ lbs. (load to be lifted)}}{7.32 \text{ (Ratio B of 8part line)}} = 9,290 \text{ lbs.}$$

9,290 lbs. single line pull required to lift this load on 8 parts of line.



To find the lift capacity when the parts of line and single line pull are known, and using anti-friction bearing sheaves.

**10,000 lbs. (Single line pull)**  
**x 4.71 (Ratio B of 5 parts of line)**  
**= 47,100 lbs. (Lift Capacity)**

10,000 lbs. single line pull with 5 parts of line will accommodate 47,100 lbs. lift capacity.

### Repairs

For repair of blocks, contact the following numbers for return material authorization.

**IN U.S.A.** – Crosby Engineered Products Group at (800) 777-1555

**IN CANADA** – Crosby Canada at (877) 462-4672

**IN EUROPE** – N.V. Crosby Europe at (+32) (0)15 75 71 25

Your block, after receipt by Crosby, will be inspected and a free estimate of repair charges will be provided. Authorization for repairs from block owners must be given to Crosby before repairs are made. Transportation charges, both to and from factory, are to be paid by the block owner.

### Additional Information

For information concerning parts, special application, or situations requiring other features, contact:

#### U.S.A.

The Crosby Group LLC  
P.O. Box 3128  
Tulsa, OK 74101-3128  
(918) 834-4611  
FAX (918) 832-0940  
www.thecrosbygroup.com  
crosbygroup@thecrosbygroup.com

#### CANADA

Crosby Canada  
3660 Odyssey Drive, #4  
Mississauga, Ontario, Canada L5M 7N4  
(877) 462-7672  
FAX (877) 260-5106  
www.thecrosbygroup.com  
sales@crosby.ca

#### EUROPE

Belgium  
Industriepark Zone B n°26  
2220 Heist-op-den-Berg.  
P: (+32) (0)15 75 71 25  
F: (+32) (0)15 75 37 64  
www.thecrosbygroup.com  
sales@crosbyeurope.com

### How to Find Your Nearest Crosby Distributor

To locate your nearest Crosby Distributor, call:

**IN U.S.A.** – Crosby Engineered Products Group at (800) 727-1555

**IN CANADA** – Crosby Canada at (877) 462-7672

**IN EUROPE** – N.V. Crosby Europe at (+32) (0)15 75 71 25

# CROSBY® TUBING GRAB

## WARNINGS & APPLICATION INSTRUCTIONS



TGRB - Tubing Grab

### WARNING

- Loads may disengage from Tubing Grab if proper procedures are not followed.
- A falling load may cause serious injury or death.
- Never exceed the Working Load Limit (WLL).
- Inspect the Tubing Grab for damage and proper operation before each use.
- Do not use with worn or damaged tubing.
- Do not allow the Tubing Grab or the load to come into contact with any other object during the lift.
- Do not allow the Tubing Grab or load to bounce or allow the hoist line to become slack during the lift.
- Do not use more than one Tubing Grab to lift a section of tubing.
- Do not attempt to detach the Tubing Grab from the tubing when loaded.
- Read and understand these instructions before using the Tubing Grab.

### Important Safety Information Read and follow

- Tubing grabs are designed to work with a specific tubing diameter. Do not attempt to lift any other type of object, or tubing of a different diameter.
- The weight of the load shall be known, calculated, estimated, or measured prior to lifting.
- Shock loading should be avoided.
- See ASME B30.20, BELOW-THE-HOOK LIFTING DEVICES; ASME BTH-1, DESIGN OF BELOW-THE-HOOK LIFTING DEVICES; NEN-EN 13155: "CRANES-SAFETY-NON-FIXED LOAD LIFTING ATTACHMENTS" for additional information.

### Operating Practices

- To install on tubing, pull the trigger fully, and press the jaws over the tubing. Release the trigger and verify the trigger is fully in the locked or forward position prior to applying a load. The operator's hands must be free of the grab prior to applying the load.
- The grab must be installed adjacent to the flared end of the tubing or the coupler (see Figures 1 & 2). Do not attempt to attach the grab directly to the larger diameter flared end or the coupler (see Figure 3).

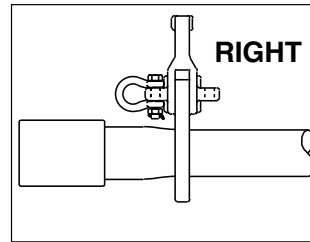

Figure 1

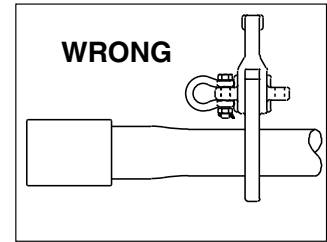

Figure 2

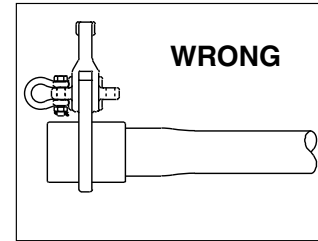

Figure 3

- The hoist line may only apply the load in a 90° range (see Figure 4). Do not apply a load in any other direction or allow the hoisting line to come into contact with the grab (see Figures 5 & 6). The hoist line must pull towards the coupler end.

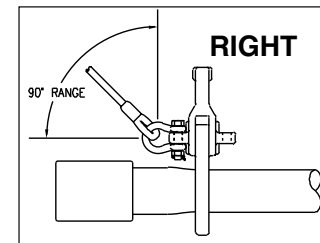

Figure 4

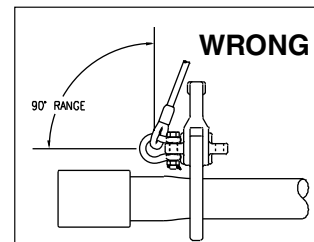

Figure 5

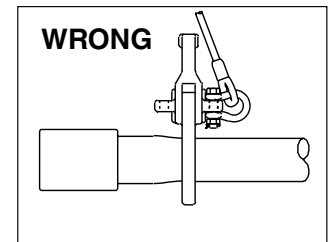

Figure 6

- After the grab has been attached to the tubing, apply force slowly. Watch the load and be prepared to stop lifting if the load moves in an uncontrolled manner.
- The grab may slide on the tubing when the load is applied; keep hands free of the tubing.
- Personnel shall stand clear of the suspended load.
- Personnel shall not be lifted by the grab or by any object connected to the grab.
- During lifting, with or without a load, personnel should be alert for possible snagging.
- The grab should not be dragged on the ground or over abrasive surface.
- Lubrication may be used to keep components moving freely and to prevent corrosion.
- The grab must be kept free of dirt and debris to ensure free movement of components.

- The tubing grab shall be removed from service if any of the following are true:
  - The trigger does not slide freely through entire operating range.
  - The jaw does not rotate freely through entire operating range.
  - The trigger spring or the pivot spring is missing, damaged, or not functioning properly.
  - The pivot pin retaining ring is missing or damaged.
  - Wear, corrosion, or loss of material exceeding 10% of any original dimension.
  - Cracks, breaks, stretching, or bending.
  - Welding, modification, or alteration of any component.
  - Missing or illegible product markings.
- Nicks, gouges, or other wear resulting in sharp corners should be repaired by grinding to restore smooth surfaces. The maximum allowance for reduction of any original dimension is 10%.
- The springs may lose strength or break through normal use and may need to be periodically replaced. Use only genuine Crosby replacement parts.
- The grab or its components may not be subjected to any plating or galvanizing process. The grab is originally supplied with a zinc plated finish and may be painted for additional corrosion control or for identification purposes. Internal sliding or mating surfaces shall not be painted.

### **Environmental Effects**

- The grab is designed for normal operating temperatures of -40°F(-40°C) to 200°F(93°C).
- Do not expose the grab to chemically active environments such as acids or corrosive liquids or fumes. The detrimental effects of chemical exposure can be both visible loss of material and undetectable material degradation resulting in significant loss of strength.



- Proof Test Capability (Blocks) – 1000 short tons
- Ultimate Test Capability – 800 short tons
- Proof Test Capability (Shackles) – 2000 metric tons
- Full reeving block testing to 1000 short tons
- Complete laboratory facilities for all phases of metalurgical testing and inspection.
- Certifications available for all national standards, American Bureau of Shipping, Lloyd's Register of Shipping, Det Norske Veritas, etc.





# “The Standard” in Cell Tower Securement

When it comes to the securment of cell towers, Crosby® sets the industry standard with superior products, in-depth training, and time-tested expertise. For years, we have fulfilled the unique needs of each and every cell tower company that we’ve partnered with.



**Turnbuckle  
Fittings**



**Wire Rope  
End Fittings**





# WESTERN & MARINE BLOCKS

With Product Warnings and Application Information

## IMPORTANT

### Helpful Information and Recommended Procedure for the Correct Ordering of Western Blocks

In selecting blocks, the governing consideration should be the load to be handled, rather than diameter or strength of the rope they will support. In multiple sheave blocks, the load is distributed among several parts of the rope, whereas the hooks or shackles on the blocks have to support the entire load. It is not practical to make double blocks twice as strong and triple blocks three times as strong as single blocks, since they would be too heavy and needlessly expensive for general use.

#### WHEN ORDERING, ALWAYS SPECIFY:

- Letter of Fitting,
- Block Series,
- Letter of Bearing, and
- Size.

#### EXAMPLE:

For ordering a 4" Single Wood Block with Loose Side Latch Hook, Common Iron Bearing, simply specify as follows:

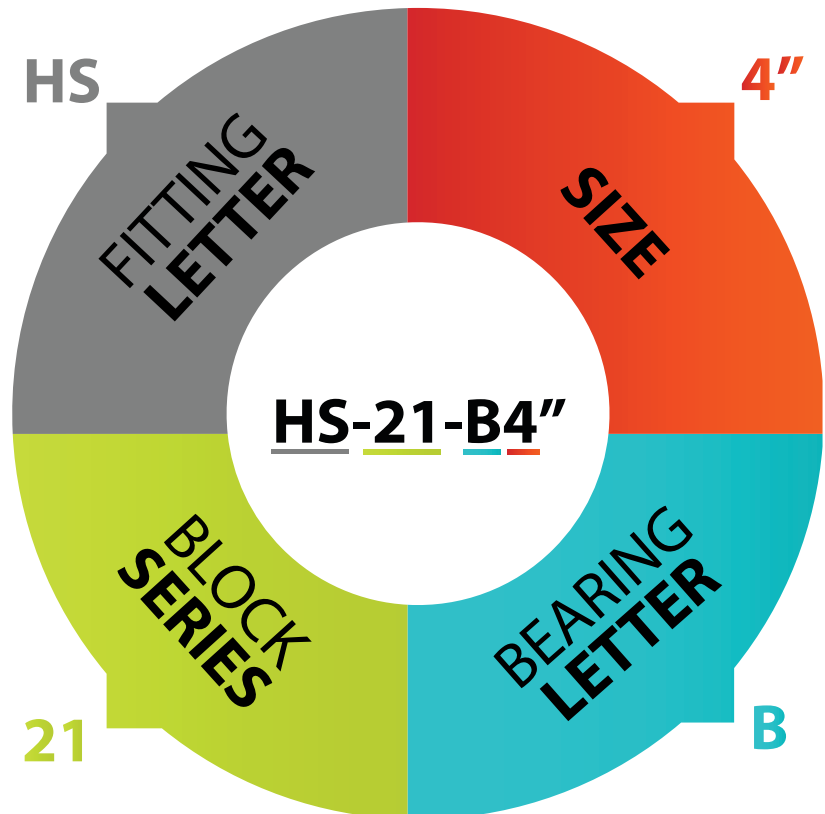

If blocks are not shown with type of fitting you require, simply choose letter corresponding to your fitting need and insert where "HS" appears in the above example.

Unless otherwise specified, all material will be furnished in galvanized finish

All certified single blocks are proof tested to twice the Resultant Safe Working Load and marked with a working load equal to one half the resultant load. Double blocks are tested to twice the Resultant Safe Working Load and marked with a working load equal to the resultant load.

All blocks except snatch blocks are furnished with becket. Blocks without becket on special order only.

When blocks are used for heavy loads and fast hoisting, we strongly recommend roller or bronze bearings in the sheaves. For wire rope blocks, cast steel sheaves are recommended.

#### SPECIAL CUSTOM-MADE BLOCKS. . .

We manufacture a large number of Special Blocks to meet particular requirements. Specify type block, diameter of sheave, diameter of manila or wire rope to be used, and weight of load.

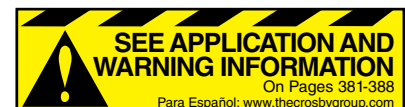





# The Western Block Line

**If today's technology was available over a century ago . . .  
this is the way Western Blocks would have been produced.**

- Bolt style center pin with lock washer and staked nut
- No straps
- Laser burned side plates
- Every block permanently stamped with the following:
  - Working Load Limit
  - Block and Rope Size

### 385 WOOD SHELL MANILA ROPE SNATCH BLOCK

- New stock numbers
- New higher working load limits
- Painted or galvanized steel
- Laser cut side plate opens for insertion of rope
  - Incorporates exclusive bolt retaining spring to assure no lost bolts, plus utilizes secondary retaining pin
- Bronze bushed sheaves with larger bearing diameter for extended block life
- Lubricated center pin
- 10" and 12" sizes utilize steel sheaves



### 301-302-303 STEEL SHELL BLOCKS FOR MANILA ROPE

- Same stock numbers
- Same working load limits
- Same fittings available
- Laser cut side plates
- Galvanized steel
- Grade 5 bolts secured with lock washers and staked nuts
- Bronze bushed sheaves with larger bearing diameter for extended block life
- New style hanger for fitting attachment



### 261-262-263 STANDARD STEEL SHELL BLOCKS FOR MANILA ROPE

- Same stock numbers
- Same working load limits
- Same fittings available
- Laser cut side plates
- Painted steel
- Grade 5 bolts secured with lock washers and staked nuts
- Bronze bushed sheaves with larger bearing diameter for extended block life



### 390 STEEL SHELL MANILA ROPE SNATCH BLOCK

- New stock numbers
- New higher working load limits
- Painted or galvanized steel
- Laser cut side plate opens for insertion of rope.
  - Incorporates exclusive bolt retaining spring to assure no lost bolts, plus utilizes secondary retaining pin
- Bronze bushed sheaves with larger bearing diameter for extended block life
- Lubricated center pin
- 10" and 12" sizes utilize steel sheaves



### 411-412-413 STEEL SHELL BLOCK FOR SYNTHETIC ROPE

- Same stock numbers
- Same working load limits
- Same fittings available
- Laser cut side plates
- Painted steel
- Grade 5 bolts secured with lock washers and staked nuts
- Bronze bushed sheaves with larger bearing diameter for extended block life



### 310 - 135 PAINTER'S SUPPLY BLOCK FOR MANILA ROPE

- Same stock numbers
- Same working load limits
- Same fittings available
- Laser cut side plates
- Galvanized steel
- Grade 5 bolts secured with lock washers & staked nuts
- Replaceable wood bumpers
- Bronze bushed sheaves with larger bearing diameter for extended block life



### 21-22-23 WOOD SHELL BLOCKS FOR MANILA ROPE

- Same stock numbers
- Same working load limits
- Same fittings available
- Laser cut side plates
- Galvanized steel
- Grade 5 bolts secured with lock washers & staked nuts
- Replaceable wood bumpers
- Bronze bushed sheaves with larger bearing diameter for extended block life.





## Regular Wood Blocks for Manila Rope

- Laser cut side plates
- Grade 5 bolts secured with lock washers and staked nuts.
- Bronze bushed sheaves with larger bearing diameter for extended block life.
- Becketts furnished on all blocks.
- For reeving information, see page 385.
- Meets or exceeds all requirements of ASME B30.26 including identification, ductility, design factor, proof load and temperature requirements. Importantly, these blocks meet other critical performance requirements including fatigue life, impact properties and material traceability, not addressed by ASME B30.26.



**HS-21-B**  
Regular Wood Block  
for Manila Rope

### HS-21B, 22B, 23B

Block Size (in)	Fitting	Single Sheave 21 B Stock No.	Double Sheave 22 B Stock No.	Triple Sheave 23 B Stock No.
4	HS	603831	604634	605438
5	HS	603859	604652	605456
6	HS	603877	604670	605474
8	HS	603911	604714	605517
4	N	606437	606838	607230
5	N	606455	606856	607258
6	N	606473	606874	607276
8	N	606516	606918	607310
4	S	610039	611635	613232
5	S	610057	611653	613250
6	S	610075	611671	613278
8	S	610119	611715	613312

Fitting Type: HS-Latch Hook; N-Swivel Hook with Latch; S- Round Pin Anchor Shackles

### HS-21B, 22B, 23B

Block Size (in)	Sheave Dimensions (in)			Manila Rope Size (in)	Working Load Limit (lb)*			Weight Each (lb)		
	Outside Diam.	Rim Thickness	Center Pin Diam.		21 Single	22 Double	23 Triple	21 Single	22 Double	23 Triple
4	2.25	.63	.38	1/2	1000	1400	1800	1.75	3.00	4.00
5	3.00	.75	.38	5/8	1200	1800	2400	3.25	5.60	6.50
6	3.50	1.00	.50	3/4	1800	2500	3200	5.00	8.50	11.50
8	4.75	1.13	.63	7/8 - 1	2800	3800	4800	13.00	14.00	21.50

\*Ultimate Load is 4 times the Working Load Limit



## Steel Shell Blocks for Manila Rope

- Laser cut side plates
- Grade 5 bolts secured with lock washers and staked nuts.
- Bronze bushed sheaves with larger bearing diameter for extended block life.
- New style hanger for fitting attachment



**P-303-B**  
Steel Shell Block  
for Manila Rope

### P-301B, 302B, 303B

Block Size (in)	Fitting	Single Sheave 301 B* Stock No.	Double Sheave 302 B* Stock No.	Triple Sheave 303 B* Stock No.
4	HS	680971	681373	681774
6	HS	680999	681391	-
8	HS	681015	681417	681818
4	N	682639	683031	683433
6	N	682675	683077	683479
8	P	691111	692717	694314

\*Bearing Code: B- Self Lubricating Bronze Bushed. Fitting Type: HS- Latch Hook; N- Swivel Hook with Latch; P- Screw Pin Anchor Shackles

### P-301B, 302B, 303B

Block Size (in)	Sheave Size (in)		Manila Rope Size (in)	Working Load Limit (lb)*			Weight Each (lb)		
	Outside Diam.	Rim Thickness		Single	Double	Triple	Single	Double	Triple
4	2.25	.63	1/2	1100	1600	2200	2.25	3.75	5.00
6	3.50	1.00	3/4	2000	3300	4000	5.50	9.25	12.50
8	4.75	1.13	1	3300	5100	7000	10.00	16.50	22.00

\*Ultimate Load is 3.5 times the Working Load Limit

# Western Standard Steel Blocks



## HS-262 Double

### Loose Side Hooks with Latch for Manila Rope

- Laser cut side plates
- Grade 5 bolts secured with lock washers and staked nuts.
- Bronze bushed sheaves with larger bearing diameter for extended block life.

### HS-262 Double, HA-261, 262, 263

Block Size (in)	Fitting	Manila Rope Size (in)	Sheave Size (in)		261 B Stock No.	262 B Stock No.	263 B Stock No.	Working Load Limit (lb)*			Weight Each (lb)		
			Outside Diam.	Rim Thickness				261 Single	262 Double	263 Triple	261 Single	262 Double	263 Triple
4	HS	1/2	2.25	.63	666826	666229	667228	900	1400	1800	1.38	3.21	3.25
5	HS	5/8	3.00	.75	666844	666247	-	1200	1800	-	2.25	3.88	-
6	HS	3/4	3.50	1.00	666862	666265	-	1800	2500	-	3.75	6.00	-
8	HS	7/8 - 1	4.75	1.13	666906	666309	667308	2800	3800	4800	7.13	10.75	14.75

\*Ultimate Load is 3 times the Working Load Limit. Fitting Type : HS - Latch Hook



## N-411B

### Blocks for Synthetic Fiber Rope with loose swivel hooks

- These blocks are built to carry the increased loads of synthetic fiber ropes
- All hooks are heat-treated alloy steel.
- You can now use a smaller size rope, and in turn, a smaller block, providing capacities which were previously not possible.
- Meets or exceeds all requirements of ASME B30.26 including identification, ductility, design factor, proof load and temperature requirements. Importantly, these blocks meet other critical performance requirements including fatigue life, impact properties and material traceability, not addressed by ASME B30.26.

### N-411B, 412B, 413B

Block Size (in)	Fitting	411 B* Stock No.	412 B* Stock No.	413 B* Stock No.
4	S	755105	755301	755506
6	S	755123	755329	755524
4	N	757103	757309	757504
6	N	757121	757327	757522

\*Bearing Code: B- Self Lubricating Bronze Bushed. Fitting Type: S- Round Pin Anchor; N- Swivel Hook Latch

### N-411B, 412B, 413B

Block Size (in)	Fitting	Sheave Size			Synthetic Rope Size (in)	Working Load Limit (lb)*			Weight Each (lb)		
		Outside Diam.	Rim Thickness	Center Pin Diam.		Single	Double	Triple	Single	Double	Triple
4	S	2.25	.62	.38	1/2	2000	3000	3000	3.00	4.00	6.00
6	S	3.50	1.00	.50	3/4	3000	7000	8000	6.25	10.00	14.00
4	N	2.25	.62	.38	1/2	2000	3000	3000	3.00	4.00	6.00
6	N	3.50	1.00	.50	3/4	3000	4000	6000	6.25	10.00	14.00

\*Ultimate Load is 4 times the Working Load Limit

**STEEL SHELL & WOOD SHELL**



**T-390**  
Painted



**T-390**  
Galvanized



**T-385**  
Painted



**T-385**  
Galvanized

- New style blocks feature higher working load limits.
- Painted or Galvanized steel with replaceable wood bumpers.
- Laser cut side plate opens for insertion of wire rope.
- Incorporates exclusive bolt retaining spring to assure no lost bolts, plus utilizes secondary retaining pin.
- Bronze bushed sheaves with larger bearing diameter for extended block life.

- Utilizes Crosby “N” style hooks with integrated latch.
- Lubricated center pin.
- 10” and 12” sizes utilize steel sheaves.
- Meets or exceeds all requirements of ASME B30.26 including identification, ductility, design factor, proof load and temperature requirements. Importantly, these blocks meet other critical performance requirements including fatigue life, impact properties and material traceability, not addressed by ASME B30.26.



**385B, 390B Blocks**

Block Size (in)	Fitting	Wood Shell		Steel Shell	
		385-B* Stock No. S.C.	385-B* Stock No. Galv.	390-B* Stock No. S.C.	390-B* Stock No. Galv.
6	T	702000	702108	702216	702324
8	T	702009	702117	702225	702333
10	T	702018	702126	702234	702342
12	T	702027	702135	702243	702351
6	J	702036	702144	702252	702360
8	J	702045	702153	702261	702369
10	J	702054	702162	702270	702378
12	J	702063	702171	702279	702387
6	G	702072	702180	702288	702396
8	G	702081	702189	702297	702405
10	G	702090	702198	702306	702414
12	G	702099	702207	702315	702423

\*Bearing Code : B - Self Lubricating Bronze Bushed; C - Common Iron; R - Roller Bearing  
Fitting Type : T - Swivel Latch Hook; J - Yoke and Oblong Swivel Eye; G - Yoke and Swivel Shackles

**385B, 390B Blocks**

Block Size (in)	Sheave Size (in)			Manila Rope Size (in)	Drop Side	
	Outside Diam.	Rim Thickness	Bearing Diameter		Working Load Limit (Tons)*	Weight Each (lbs.)*
6	3.00	.88	.75	3/4 - 7/8	2	7
8	4.00	1.38	1.00	1 - 1-1/8	4	13
10	6.00	1.62	1.50	1-1/4	8	28
12	8.00	1.62	1.50	1-1/2	8	34

\*Ultimate Load is 4 times the Working Load Limit.

# Western Blocks for Manila Rope



**T-350-C**  
Gin Block

## Gin Blocks for Manila Rope

- For light hoisting by Roofers and Contractors.
- Furnished with drop forged swivel latch hooks.

## 350C, 350B, 350R

Block Size (in)	Fitting	Gin Block Stock No.			Sheave Size (in)			Manila Rope Size (in)	Working Load Limit (lb)*	Weight Each (lb)
		T-350-B	T-350-R	T-350-C	Outside Diam.	Rim Thickness	Bearing Diam.			
8	T	710403	710207	710001	8.00	1.25	.75	7/8	1000	9.0
10	T	710421	710225	710029	10.00	1.25	.88	1	1000	9.8
12	T	710449	710243	710047	12.00	1.38	.88	1	1000	12.7

\*Ultimate Load is 3 times the Working Load Limit.

Bearing Code : B - Self Lubricating Bronze Bushed; R - Roller Bearing; C - Common Iron  
Fitting Type : T - Swivel Latch Hook



**HS-130-B**  
Single

## Painter's Supply Blocks for Manila Rope

- Furnished in Bronze Bushed.
- For 3/4" Manila Rope.
- Steel Parts are Galvanized.
- Furnished with Loose Side Hooks with Latch or Shackle.
- Meets or exceeds all requirements of ASME B30.26 including identification, ductility, design factor, proof load and temperature requirements. Importantly, these blocks meet other critical performance requirements including fatigue life, impact properties and material traceability, not addressed by ASME B30.26.

## HS-130B, HS-135B, P-135B

Block Size (in)	Fitting	Single Sheave Blocks	Double Sheave Blocks	
		HS-130 B* Stock No.	HS-135 B* Stock No.	P-135 B* Stock No.
6	HS	601236	631034	-
6	HS	-	-	8004829

\*Bearing Code : B - Self Lubricating Bronze Bushed  
Fitting Type : HS - Latch Hook, P= Screw pin anchor shackle.

## HS-130B, HS-135B, P-135B

Block Size (in)	Sheave Size (in)			Manila Rope Size (in)	Resultant Working Load Limit (lb)*		Weight Each (lb)	
	Outside Diam.	Rim Thickness	Center Pin Dia.		130 Single	135 Double	130 Single	135 Double
6	3.50	1.00	.75	3/4	1800	2500	5	10

\*Ultimate Load is 4 times the Resultant Working Load Limit.

Western & Marine Blocks



TRY NET BLOCKS



F-453 6"



F-454 6"



J-454 8"

- Forged steel swivel eyes.
- Hot Dip galvanized.
- 6" 453 - Pressed steel side plates with flared edges. Figure 8 grooved, self-lubricating bronze bushed sheaves, with pressure lube fittings. 453 has an extra wide throat opening to allow fittings to pass through.
- 6" 454 - Forged side plates designed to eliminate rope jamming. Wide throat opening and pressure lube fitting on sheave and eye fitting
- 8" 454 - Forged steel side plates designed to eliminate possibility of rope jamming. Furnished with sealed tapered bearings. Flame hardened forged steel sheaves for wear resistance.

**SEE APPLICATION AND WARNING INFORMATION**  
 On Pages 381-388  
 Para Español: [www.thecrosbygroup.com](http://www.thecrosbygroup.com)

453, 454, Blocks

Sheave Dia. and Block No.	Bearing Type	Try Net Block Stock No.	Working Load Limit (Tons)*	Weight Each (lb)	Sheave Dimensions (in)	
					Outside Diameter	Rim Thickness
6" F-453	Bronze Bushed	769886	5	35	6	2-3/4
6" F-454	Needle Bearing	2001763	5	23	6	2-3/4
8" J-454	Tapered Bearing	130726	10	36	8	2-7/8

\*Ultimate Load is 4 times the Working Load Limit.

## DOUBLE RIG TRAWL BLOCKS



**J-452**  
Oblong Swivel  
Eye

### Double Rig Trawl Blocks

- Steel sheave with flame hardened groove, for maximum wear under abrasive conditions.
- Double row, permanently sealed tapered roller bearings.
- Pressure lubrication throughout.
- All steel construction.
- Hot Dip galvanized.



### J452 Blocks

Sheave Dia. and Block No.	452 Stock No.	Working Load Limit (Tons)*	Weight Each (lb)	Sheave Dimensions (in)	
				Outside Diam.	Rim Thickness
8" J-452	130655	10	48	8	3.75
12" J-452	130673	10	85	12	3.75
16" F-452	130682	20	116	16	3.75
18" J-452	2015467	25	300	18	5.44
22" F-452	130708	30	240	22	3.75

\*Ultimate Load is 4 times the Working Load Limit. NOTE: 18" J-452 utilizes a Manganese Steel Sheave that is not flame hardened.

## CARGO HOISTING BLOCKS

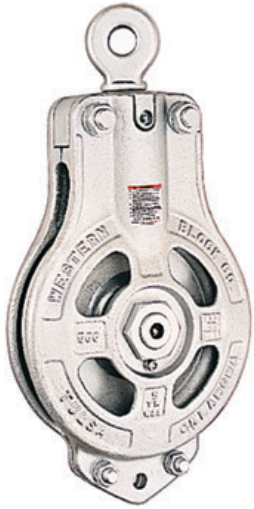

**E-566**  
with Drilled  
Swivel Eye

- Block is galvanized.
- Blocks 14" and larger have flame-hardened roll forged sheaves that assure greater wire life.
- Roll forged sheave is fitted closely into mortise of shell so wire cannot jam between sheave and shell.
- Available for 3/4" or 1" wire.
- Block is fitted with tapered roller bearings which take both load and side thrusts and hold sheave central so it cannot chafe or wear on the sides.
- Tapered Roller bearing with neoprene seals and stainless steel center pin provide long life and trouble-free service.
- Stainless steel center pin has recessed nuts with lock washers.
- Swivel fitting has permanently sealed thrust bearing.
- Pressure lubrication fittings are standard on both center pin and swivel.
- Individually Proof Tested at 4 times Working Load or 2 times Resultant Load.
- A.B.S. recognized load test certificates are furnished.
- The Working Load for cargo hoisting blocks is the line pull.



**J-566**  
with Oblong  
Swivel Eye



### 566 Hoisting Blocks

Sheave Size (in)	Block No.	566 Stock No.	Working Load Limit (Tons)*	Wire Rope Size (in)	Weight Each (lb)
12	E-566	775003	5	3/4	95
12	J-566	775209	5	3/4	95
12	G-566	775405	5	3/4	95
12	K-566	775600	5	3/4	95
12	QG-566	775806	5	3/4	95
12	QK-566	776002	5	3/4	95
14	E-566	775058	10	3/4	100
14	J-566	775254	10	3/4	100
14	QG-566	775450	10	3/4	100
14	QK-566	775655	10	3/4	100
14	PG-566	775851	10	3/4	100
14	PK-566	776057	10	3/4	100
14	E-566	775067	10	1	100
14	J-566	775263	10	1	100
14	QG-566	775469	10	1	100
14	QK-566	775664	10	1	100
14	PG-566	775860	10	1	100
14	PK-566	776066	10	1	100
16	E-566	776609	10	3/4	130
16	J-566	776672	10	3/4	130
16	QG-566	776681	10	3/4	130
16	QK-566	776690	10	3/4	130
16	PG-566	776707	10	3/4	130
16	PK-566	776716	10	3/4	130
16	E-566	752956	10	1	130
16	J-566	752965	10	1	130
16	QG-566	752974	10	1	130
16	QK-566	752983	10	1	130
16	PG-566	752992	10	1	130
16	PK-566	753009	10	1	130

\*Working Load equals maximum single line pull. Resultant Load equals 2 times single line pull. Ultimate Load equals 5 times the Resultant Load.

# Fittings for Western Cargo Blocks

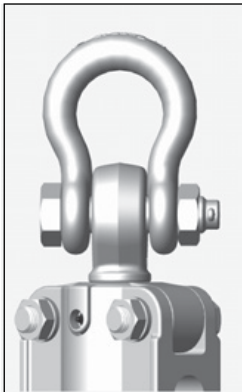

**QG**  
Swivel Bolt Type  
Shackle



**J**  
Oblong Swivel  
Eye

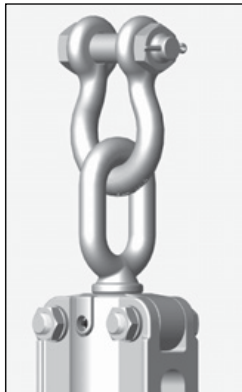

**QK**  
Upset Swivel  
Bolt Type



**U**  
Goose Neck  
Swivel Eye



**Z**  
Non-toppling  
Guard

## HEEL AND LEAD BLOCK ADJUSTER FITTINGS

(For use with E-566 Cargo Blocks)

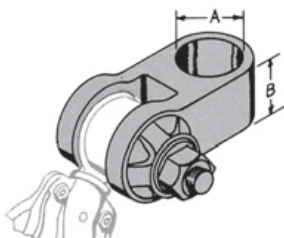

**No. 572**

Self-adjuster Fitting with Tension Pin, Cup Spring and Washers.

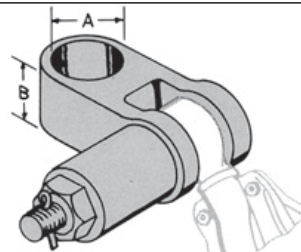

**No. 573**

Self-adjuster Fitting with Tension Pin, Coil Spring, Cup and Washers.

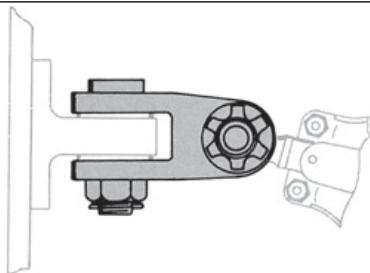

**No. 574**

Self-adjuster Fitting with Tension Pin, Cup Spring and Washers, and King Pin to fit Pad Eye (can also be furnished with 2 Tension Pins).

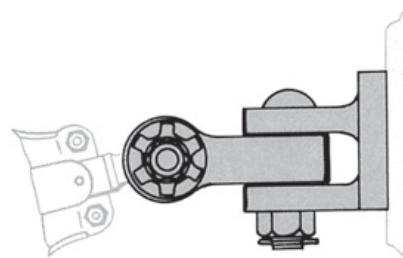

**No. 576**

Self-adjuster Fitting with Pad Jaw, King Pin, Tension Pin, Cup Spring and Washers.

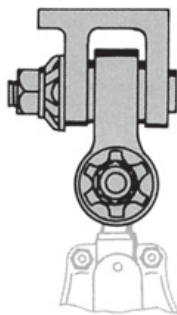

**No. 575**

Self-adjuster Fitting with Tension Pin, Cup Spring, and Washer.

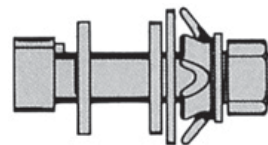

**No. 571**

Tension Pin with Cup Spring, Nut and Washers.

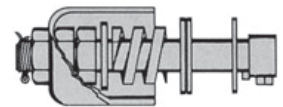

**No. 570**

Tension Pin with Coil Spring, Nut and Washers, Cotter and Cup.

When ordering Specify: "A" - Pin Diameter, "B" -Height of Fitting, and Tension Pin Diameter.





**S-600S**  
Horizontal Lead Block

**Horizontal Lead Blocks**

- Available painted or galvanized.
- Fitted with steel sheaves.
- Self Lubricated Bronze Bushed.

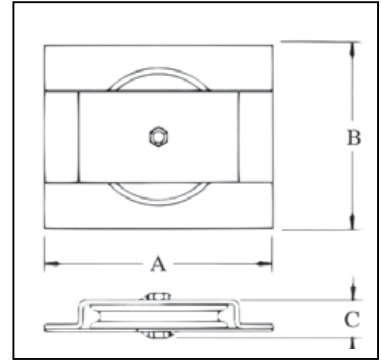

**S-600S / G-600S**

Sheave Diameter (in)	600 Series Stock No.		Resultant Working Load Limit (Tons)*	Wire Rope Size (in)	Weight Each (lb)	Dimensions (in)		
	S-600-S Painted	G-600-S Galv.				A	B	C
6	771999	772006	2	3/8	10.0	11.00	6.38	2.50
8	772015	772024	2-1/2	1/2	21.0	13.00	8.50	3.00
10	772033	772042	3	5/8	36.0	15.00	10.50	3.25
12	772051	772060	4	3/4	61.0	17.00	12.50	4.00
14	772079	772088	5	7/8	96.0	19.00	14.50	4.00

\*Ultimate Load is 4 times the Resultant Working Load Limit.



**G-601S**  
Vertical Lead Block

**Vertical Lead Blocks**

- Available painted or galvanized.
- Fitted with steel sheaves.
- Self Lubricated Bronze Bushed.

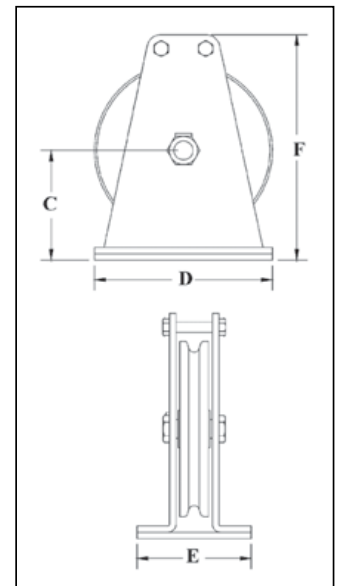

**S-601S / G-601S**

Sheave Diameter (in)	601 Series Stock No.		Resultant Working Load Limit (Tons)*	Wire Rope Size (in)	Weight Each (lb)	Dimensions (in)			
	S-601-S Painted	G-601-S Galv.				C	D	E	F
6	772195	772202	2	3/8	10.00	3.50	6.00	5.50	7.00
8	772211	772220	2-1/2	1/2	24.50	4.88	8.00	6.75	9.75
10	772239	772248	3	5/8	31.50	6.38	10.00	7.75	11.75
12	772257	772266	4	3/4	60.00	7.25	12.00	6.00	15.25
14	2003424	2003425	5	7/8	98.00	8.75	14.00	9.00	18.00

\*Ultimate Load is 4 times the Resultant Working Load Limit.

# Western Lead Blocks



**G-602S**  
Flag Lead Block

## Flag Blocks

- Base plates are drilled.
- Available painted or galvanized.
- Fitted with steel sheaves.
- Self-lubricated Bronze Bushed.

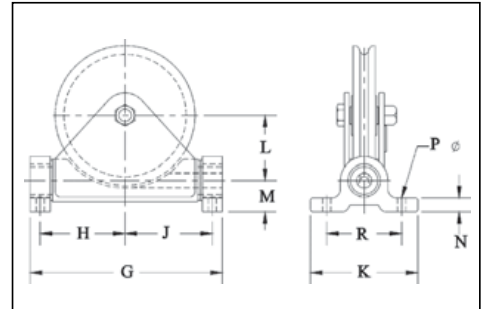

## S-602S / G-602S Flag Blocks

Sheave Diameter (in)	602 Series Stock No.		Resultant Working Load Limit (Tons)*	Wire Rope Size (in)	Weight Each (lb)	Dimensions (in)								
	S-602-S Painted	G-602-S Galv.				G	H	J	K	L	M	N	P	R
6	772391	772408	2	3/8	17.00	9.00	3.75	3.88	6.25	2.88	1.62	.75	.56	4.75
8	1420885	772426	2-1/2	1/2	31.50	11.38	4.75	5.12	7.00	3.62	2.00	1.00	.69	5.50
10	772435	772444	3	5/8	42.00	13.38	5.69	6.06	7.00	4.62	2.00	1.00	.69	5.50
12	772453	772462	4	3/4	115.00	17.25	7.25	7.75	10.75	5.38	3.12	1.38	.81	7.50
14	772471	-	5	7/8	136.50	19.25	8.50	8.75	10.75	6.50	3.12	1.38	.81	7.50

\*Ultimate Load is 4 times the Resultant Working Load Limit.



**S-603S**  
Hinged Lead Block

## Hinged Lead Blocks

- Base plates are not drilled.
- Available painted or galvanized.
- Self-lubricated Bronze Bearings.

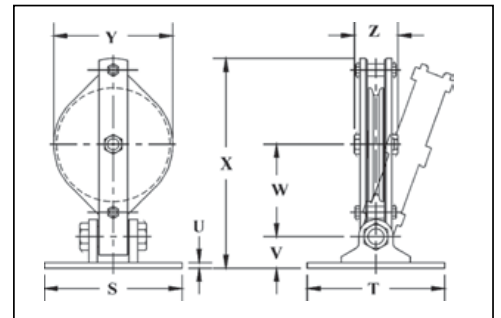

Western & Marine Blocks

## S-603S / G-603S Hinged Lead Blocks

Sheave Diameter (in)	603 Series Stock No.		Resultant Working Load Limit (Tons)*	Wire Rope Size (in)	Weight Each (lb)	Dimensions (in)							
	S-603-S Painted	G-603-S Galv.				S	T	U	V	W	X	Y	Z
6	772596	772603	2	3/8	30.00	6.00	4.50	.50	2.00	5.81	12.80	6.75	3.25
8	772612	772621	2-1/2	1/2	34.00	8.00	6.75	.38	2.62	6.56	15.48	9.00	3.75
10	772630	772649	3	5/8	45.00	12.00	12.00	.50	2.75	8.00	18.25	10.75	4.38
12	772658	772667	4	3/4	75.00	12.00	12.00	.50	2.75	9.50	18.63	13.00	4.58
14	772676	772685	5	7/8	100.00	12.00	12.00	.50	2.75	10.75	20.63	15.00	4.81

\*Ultimate Load is 4 times the Resultant Working Load Limit.

# McKissick® Horizontal & Vertical Blocks

461 Vertical Lead Block

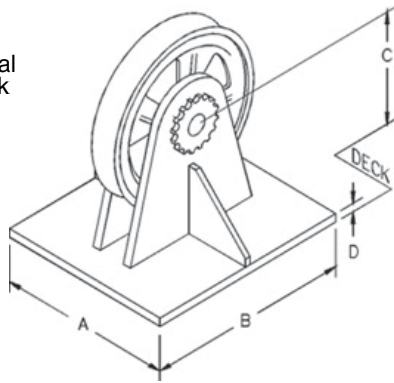

463 Horizontal Lead Block

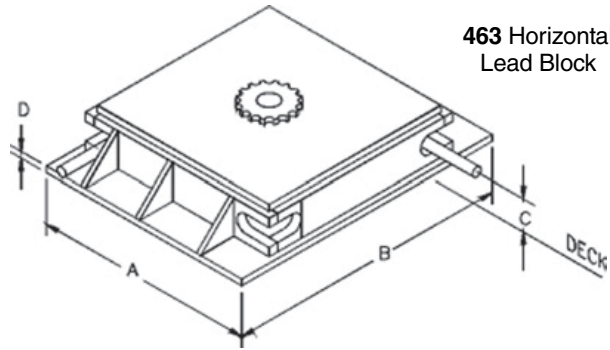

Furnish the following important information when ordering:

- A, B and C dimensions.
- Line pull in pounds and degree of wrap.
- Line speed.
- Diameter of wire rope.
- Roller bearings, bronze bushings, or sealed double row tapered bearings.

Guide and control your deck lines with McKissick's deck-mounted wire rope blocks. Built to your specific requirements.

- Extra heavy construction, built to withstand breaking strength of indicated rope (XIP, IWRC).
- Flame-hardened sheaves, machined grooves for proper rope size.
- For special requirements contact Crosby.

## 461 Vertical & 463 Horizontal Lead Blocks

Figure No.	Lead Block Stock No.	Sheave Diameter (in)	Standard Wire Rope Size (in)	Weight Each (lb)	Dimensions (in)			
					A	B	C	D
461-18	239753	18	7/8	500	12.00	20.00	11.00	1.50
461-24	131574	24	1-1/4	500	15.00	26.00	14.00	1.50
461-26	238120	26	1-1/2	660	16.00	28.00	15.00	1.50
461-36	148389	36	1-5/8	850	20.00	36.00	19.50	2.00
461-40	136285	40	2	2006	23.00	42.00	22.50	2.00
461-42	130753	42	2-1/2	4000	28.00	52.00	25.50	2.50
463-26	4440359	26	1	988	33.00	33.00	3.75	1.50
463-30	1404377	30	1-1/4	1225	37.00	37.00	3.50	1.50
463-36	146522	36	1-1/2	1900	43.00	43.00	3.50	1.50
463-42	1406525	42	1-3/4	2975	50.00	50.00	4.38	2.00
463-48	131583	48	2	3600	55.00	55.00	4.63	2.00
463-60	123164	60	2-1/2	6400	68.00	68.00	5.75	2.00

For custom orders contact our Block Hotline, (1-800-727-1555) or reference the special request form on pg 458.

457 Deck Mounted Anchor Fairleader

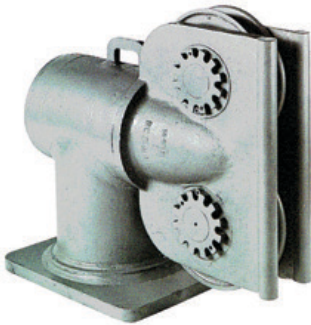

## Deck Mounted Anchor Fairleader

- Barrel and sheaves equipped with sealed double row tapered bearings.
- Extra heavy construction, built to withstand breaking strength of indicated rope at 90 degree sheave wrap and 45 degree head swing.
- All bearings Alemite-lubricated.
- Custom Anchor Fairleader sets available.

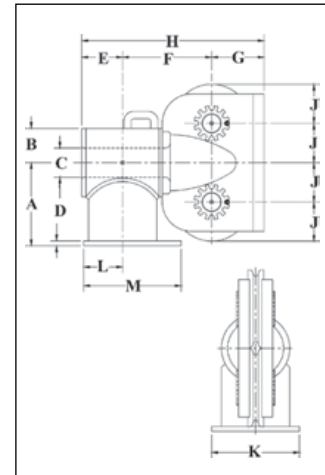

## 457 Deck Mounted Anchor Fairleader

Figure No.	457 Stock No.	Sheave Diameter (in)	Wire Rope Size (in)	Weight Each (lb)	Dimensions (in)												
					A	B	C	D	E	F	G	H	J	K	L	M	
B-10-D	8073880	10	1	300	10.75	4.50	3.50	.75	5.00	10.13	6.75	21.88	5.06	9.50	4.50	11.00	
B-12-D	8073924	12	1-1/4	600	12.75	5.00	5.00	.75	6.38	12.38	8.00	26.75	6.06	11.00	5.25	13.00	
B-16-D	8073979	16	1-1/2	1300	17.00	7.00	6.00	1.00	8.44	17.75	10.75	36.94	8.06	18.00	8.00	20.00	
B-20-D	8074022	20	1-3/4	2500	21.00	9.00	8.50	1.00	11.25	21.94	12.75	45.94	10.06	21.00	10.00	24.50	
B-24-D	8074111	24	2	3600	25.25	11.00	10.00	1.25	12.75	26.50	14.75	54.00	12.06	23.00	11.00	27.00	

## NEW STYLE OVAL PATTERN CONSTRUCTION BLOCKS



Q-681-Z



Q-682-Z



Q-683-Z

- All blocks are galvanized.
- Sheave lubricated through pressure lube fitting in center pin.
- Assembled with self lubricated bronze bushing.
- Combines weight of regular oval blocks with strength of extra heavy oval blocks.
- Assembled with bolt type anchor shackle.
- Side plates are rounded to provide additional stiffness and reduce wear and chaffing of the rope

### Q-681-Z / Q-682-Z / Q-683-Z

Block Size (in)	Fitting	Stock No. Bronze Bushed Steel Sheaves		
		Q-681-Z	Q-682-Z	Q-683-Z
6	Q	760441	760665	-
6	Q	760452	760676	760812
8	Q	760463	760687	760823
10	Q	760474	760698	760834

Fitting Type : Q - Bolt Type Anchor Shackle

### Q-681-Z / Q-682-Z / Q-683-Z

Block Size (in)	Sheave Dimensions (in)			Wire Rope Size (in)	Working Load Limit (Tons)*			Weight Each (lb)		
	Outside Diam.	Rim Thickness	Center Pin Dia.		Single	Double	Triple	Single	Double	Triple
6	6	1.00	.75	3/8	3	4	-	15	28	-
6	6	1.00	.75	1/2	3	4	5	16	28	32
8	8	1.25	1.00	5/8	4	6	7	29	43	62
10	10	1.25	1.00	5/8	4	7	8	38	61	80

\*Ultimate Load is 4 times the Working Load Limit. Bearing Code: Z - Self Lubricating Bronze Bushed with pressure lube fitting.

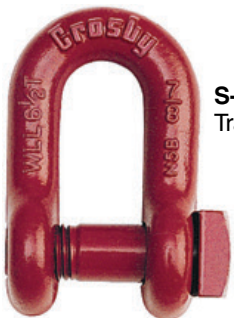

S-2131  
Trawling Shackles

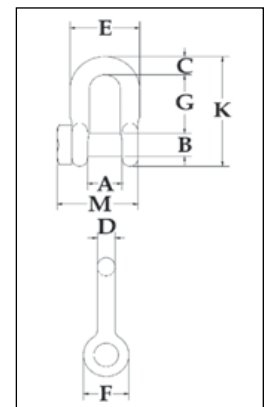

### S-2131 Trawling Shackles

Nominal Shackle Size D (in)	Working Load Limit (t)*	S-2131 Stock No.	Weight Each (lb)	Dimensions (in)									Tolerance +/-	
				A	B	C	D	E	F	G	K	M	G	A
1/2	2	1018703	.75	.81	.63	.50	.50	1.81	1.19	1.63	3.09	2.22	.13	.06
5/8	3-1/4	1018721	1.24	1.06	.75	.63	.63	2.31	1.56	2.00	3.78	2.75	.13	.06
3/4	4-3/4	1018749	2.18	1.25	.88	.81	.75	2.75	1.88	2.38	4.50	3.25	.25	.06
7/8	6-1/2	1018767	3.28	1.44	1.00	.97	.88	3.19	2.13	2.81	5.25	3.69	.25	.06

\*Ultimate Load is 4 times the Working Load Limit.



**FOR MANILA OR WIRE ROPE BLOCKS**

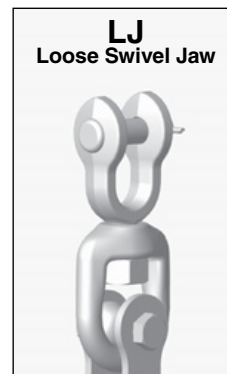
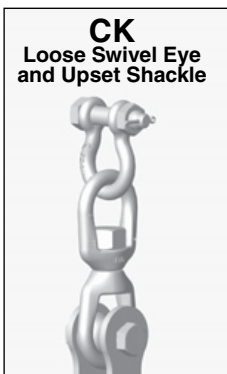
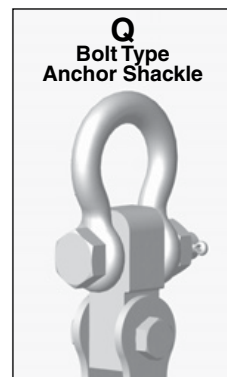
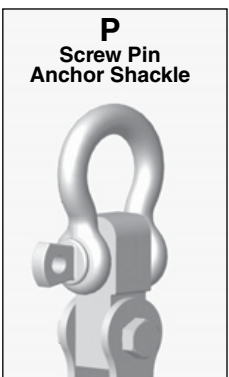
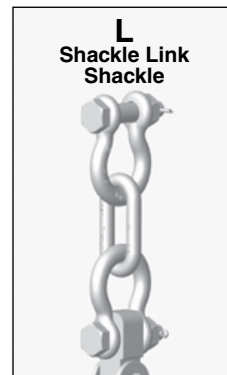
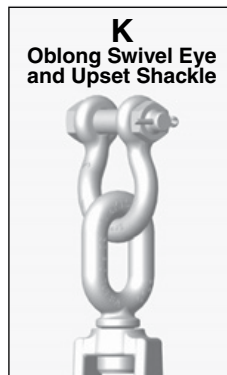
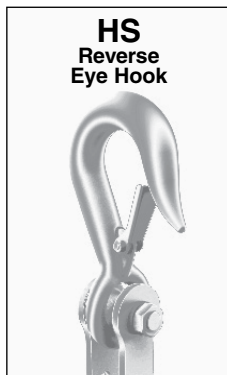
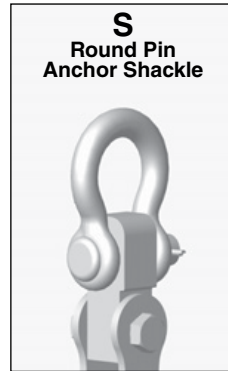



# CROSBY® LIFTING CLAMPS





**IPU10**

The IPU10 vertical lifting clamp is used for lifting, turning, moving or vertical transfer of sheet, plates, or fabrications from horizontal to vertical and down to horizontal (180°) as needed. The hinged hoisting eye allows for the clamp to place and lift the load from any direction, or with a multiple leg sling without side-loading the clamp.

## Universal - for lifting in any direction

- Available in capacities of .5 thru 30 metric tons (Higher Working Load Limits are available upon request).
- Wide variety of jaw openings available: 0" to 6.1".
- Welded alloy steel body for strength and smaller size. Forged alloy components, where required.
- Individually Proof Tested to 2 times the Working Load Limit with certification.
- Company name (CrosbyIP), logo, Working Load Limit and jaw opening permanently stamped on body.
- Each product is individually serialized, with the serial number and Proof Load test date stamped on body. User manual with test certificate is included with each clamp
- Available in a variety of styles:
  - IPU10 - Standard clamp for materials with a surface hardness to 363HV10 (345 HB).
  - IPU10J - Larger jaw opening.
  - IPU10S - For use with Stainless Steel material.
  - IPU10H - For use with materials with a surface hardness to 472HV10 (450 HB).
- Full 180° turning range for material transfer, turning or moving.
- Lock open, lock closed ability with latch for pretension on material and then release of material.
- Optional IP-5000 Stinger assembly available (see page 428). Allows for easy connection between the clamp and hoist hook.
- For use with materials with a surface hardness to 279HV10. Only 5% minimum WLL is needed.
- Maintenance and repair kits are available.
- Manufactured by an ISO 9001 facility.
- All sizes are **RFID EQUIPPED**.
- Minimum WLL is 5% of maximum WLL for .5t IPU10 only.
- Minimum WLL is 10% of maximum WLL for all other IPU10, IPU10J, IPU10S, IPU10H clamps.



**IPU10S**

**IPU10S:** For use with Stainless Steel material.  
**IPU10H:** For use with materials with a surface hardness to 47Rc (450 HB).



**Load Rated®**

## Model IPU10 / IPU10J / IPU10S / IPU10H

Model	Working Load Limit (t)*	IPU10 Stock No.	Weight Each (lb)	Dimensions (in)									
				Jaw A	B	C	D	E	F	G	H	J	K
IPU10	0.5	2701675	4.19	0 - 0.63	1.73	5.12	8.50	1.57	4.53	1.65	1.10	-	0.43
IPU10	1	2701663	5.29	0 - 0.75	1.77	5.47	8.86	1.57	5.00	1.65	1.50	-	0.43
IPU10	2	2701677	18.3	0 - 1.38	3.07	7.91	14.49	2.76	7.40	2.52	2.17	-	0.63
IPU10	3	2701665	32.6	0 - 1.56	3.94	9.96	17.17	2.95	8.74	3.07	2.36	-	0.79
IPU10	4.5	2701667	35.3	0 - 1.56	3.94	9.96	17.17	2.95	8.94	3.23	2.56	-	0.79
IPU10	6	2701669	52.9	0 - 2.00	4.96	11.89	20.67	3.15	11.50	3.31	3.74	1.73	0.79
IPU10	9	2701671	65.0	0 - 2.00	4.96	12.80	21.73	3.15	12.20	3.70	4.09	1.73	0.79
IPU10	12	2701679	126	0 - 2.13	6.30	15.43	24.25	3.15	17.05	4.76	5.39	1.61	0.98
IPU10	16	2701683	174	0.2 - 2.50	7.09	18.23	28.98	3.46	19.37	4.76	6.02	1.77	0.98
IPU10	22.5	2701687	278	0.2 - 3.13	8.74	21.81	33.98	4.33	22.24	5.47	7.32	1.93	0.98
IPU10	30	2701691	311	0.2 - 3.13	8.74	21.81	34.17	4.33	22.83	6.02	7.32	2.13	1.18
IPU10J	3	2702465	38.1	1.57 - 3.15	4.53	10.63	17.01	2.95	10.91	3.07	2.64	-	0.79
IPU10J	6	2702469	58.4	2.00 - 4.00	4.96	11.89	20.28	3.15	13.23	3.31	3.74	1.73	0.79
IPU10J	9	2701673	67.2	2.00 - 4.00	4.96	12.80	21.65	3.15	14.17	3.70	4.13	1.73	0.79
IPU10J	12	2701681	143	2.13 - 4.25	7.01	17.24	26.06	3.15	19.33	4.76	5.35	1.61	0.98
IPU10J	16	2701685	187	2.50 - 5.00	8.19	20.51	30.87	3.46	22.13	4.76	6.30	1.77	0.98
IPU10J	22.5	2701689	328	3.13 - 6.13	10.04	24.72	36.93	4.33	25.98	5.47	7.72	1.93	0.98
IPU10J	30	2701693	364	3.13 - 6.13	10.04	24.72	37.09	4.33	25.98	6.02	7.72	2.13	1.18
<b>For stainless steel - with universal hoisting eye</b>													
IPU10S	0.5	2702275	4.19	0 - 0.63	1.73	5.12	8.50	1.57	4.53	1.65	1.10	-	0.43
IPU10S	1	2702263	5.29	0 - 0.75	1.77	5.47	8.86	1.57	5.00	1.61	1.50	-	0.43
IPU10S	2	2702277	18.7	0 - 1.38	3.07	7.91	14.49	2.76	7.40	2.52	2.17	-	0.63
IPU10S	3	2702265	32.6	0 - 1.56	3.94	9.96	17.17	2.95	8.74	3.07	2.36	-	0.79
IPU10S	4.5	2702267	35.3	0 - 1.56	3.94	9.96	17.17	2.95	8.94	3.23	2.56	-	0.79
IPU10S	6	2702269	52.9	0 - 2.00	4.96	11.89	20.67	3.15	11.50	3.31	3.74	1.73	0.79
IPU10S	9	2702271	65.0	0 - 2.00	4.96	12.80	21.73	3.15	12.20	3.70	4.09	1.73	0.79
IPU10S	12	2702279	126	0 - 2.13	6.30	15.43	24.25	3.15	17.05	4.76	5.39	1.61	0.98
<b>For very hard materials - with universal hoisting eye</b>													
IPU10H	0.5	2702175	4.19	0 - 0.63	1.73	5.12	8.50	1.57	4.53	1.65	1.10	-	0.43
IPU10H	0.75	2702163	5.29	0 - 0.79	1.77	5.47	8.86	1.57	5.00	1.61	1.50	-	0.43
IPU10H	1	2702177	18.3	0 - 1.38	3.07	7.91	14.49	2.76	7.40	2.52	2.17	-	0.63
IPU10H	2	2702165	32.6	0 - 1.56	3.94	9.96	17.17	2.95	8.74	3.07	2.36	-	0.79
IPU10H	3	2702167	35.3	0 - 1.56	3.94	9.96	17.17	2.95	8.94	3.23	2.56	-	0.79
IPU10H	4.5	2702169	52.9	0 - 2.00	4.96	11.89	20.67	3.15	11.50	3.31	3.74	1.73	0.79
IPU10H	6	2702171	65.0	0 - 2.00	4.96	12.80	21.73	2.76	12.20	3.70	4.09	1.73	0.79

\* Design Factor based on EN 13155 and ASME B30.20. Model IPU10R (remote control opening and closing via a cable) on request. Model IPU10W (wedge) available on request.

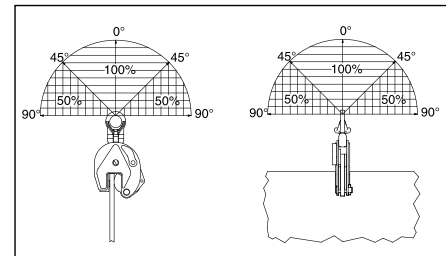
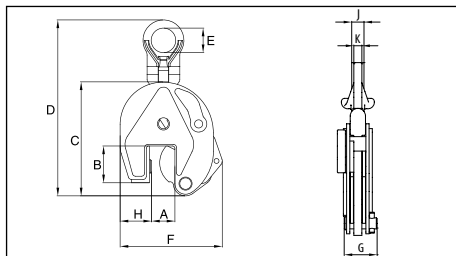

# Vertical Clamps

## For vertical lifting, turning and transfer



IP10

- Available in capacities of .5 thru 30 metric tons (Higher Working Load Limits are available upon request).
- Wide variety of jaw openings available: 0 to 6.1”.
- Welded alloy steel body for strength and smaller size. Forged alloy components, where required.
- Individually Proof Tested to 2 times the Working Load Limit with certification
- Company name (Crosby/IP), logo, Working Load Limit and jaw opening permanently stamped on body.
- Each product is individually serialized, with the serial number and Proof Load test date stamped on body. User manual and test certificate included with each clamp
- Available in a variety of styles:
  - IP10 - Standard clamp for materials with a surface hardness to 363HV10 (345 HB).
  - IP10J - Larger jaw opening.
  - IP10S - For use with Stainless Steel material.
  - IP10H - For use with materials with a surface hardness to 472HV10 (450 HB).
- Full 180° turning range for material transfer, turning or moving.
- Lock open, lock closed ability with latch for pretension on material and then release of material.
- Optional IP-5000 Stinger assembly available (see page 428). Allows for easy connection between the clamp and hoist hook.
- For plate surface hardness till 279HV10, only 5% min. WLL is needed.
- Maintenance and repair kits are available.
- Manufactured by an ISO 9001 facility.
- All sizes are **RFID EQUIPPED**.
- Minimum WLL is 5% of maximum WLL for .5t IP10 only.
- Minimum WLL is 10% of maximum WLL for all other IP10, IP10J, IP10S, IP10H clamps.

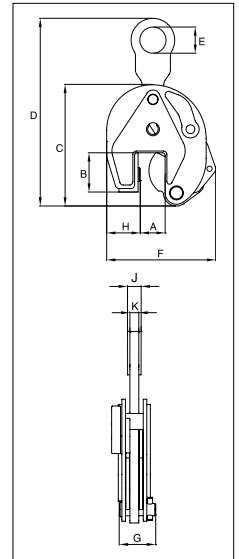

Model	Working Load Limit (t)*	IP10 Stock No.	Weight Each (lb)	Dimensions (in)									
				Jaw A	B	C	D	E	F	G	H	J	K
IP10	0.5	2701674	3.97	0 - 0.63	1.73	5.12	7.99	1.57	4.53	1.65	1.10	-	0.43
IP10	1	2701662	4.85	0 - 0.75	1.77	5.47	8.35	1.57	5.00	1.65	1.50	-	0.43
IP10	2	2701676	16.8	0 - 1.38	3.07	7.91	12.99	2.76	7.40	2.52	2.17	-	0.63
IP10	3	2701664	30.4	0 - 1.56	3.94	9.96	17.09	2.95	8.74	3.07	2.36	-	0.79
IP10	4.5	2701666	33.1	0 - 1.56	3.94	9.96	17.09	2.95	8.94	3.23	2.56	-	0.79
IP10	6	2701668	51.8	0 - 2.00	4.96	11.89	20.35	3.15	11.50	3.31	3.74	1.57	0.79
IP10	9	2701670	60.6	0 - 2.00	4.96	12.80	17.52	3.15	12.20	3.70	4.09	1.73	0.98
IP10	12	2701678	108	0 - 2.13	6.30	15.43	22.60	3.15	17.05	4.76	5.39	1.61	0.98
IP10	16	2701682	150	0.25 - 2.50	7.09	18.23	27.01	3.46	19.37	4.76	6.02	1.93	0.98
IP10	22.5	2701686	243	0.25 - 3.13	8.74	21.81	31.81	4.33	22.24	5.47	7.32	1.93	0.98
IP10	30	2701690	273	0.25 - 3.13	8.74	21.81	31.61	4.33	22.24	6.02	7.32	2.13	1.18
IP10J	0.5	2701646	3.97	0.59 - 1.18	1.77	5.04	8.23	1.57	5.04	1.61	1.26	-	0.43
IP10J	6	2701705	54.0	2.00 - 4.00	4.96	11.89	19.92	3.15	13.23	3.31	3.74	1.57	0.79
IP10J	9	2701672	62.8	2.00 - 4.00	4.96	12.80	21.34	3.15	14.17	3.70	4.13	1.73	0.98
IP10J	12	2701680	128	2.13 - 4.25	7.01	17.24	24.41	3.15	19.33	4.76	5.35	1.61	0.98
IP10J	16	2701684	176	2.50 - 5.00	8.19	20.51	28.90	3.46	22.13	4.76	6.30	1.77	0.98
IP10J	22.5	2701688	289	3.13 - 6.13	10.04	24.72	34.76	4.33	25.98	5.47	7.72	1.93	0.98
IP10J	30	2701692	324	3.13 - 6.13	10.04	24.72	34.92	4.33	25.98	6.02	7.72	2.13	1.18
<b>For stainless steel - with fixed hoisting eye</b>													
IP10S	0.5	2702274	3.97	0 - 0.63	1.73	5.12	7.99	1.57	4.53	1.65	1.10	-	0.43
IP10S	1	2702262	4.85	0 - 0.75	1.77	5.47	8.35	1.57	5.00	1.65	1.50	-	0.43
IP10S	2	2702276	16.8	0 - 1.38	3.07	7.91	12.99	2.76	7.40	2.52	2.17	-	0.63
IP10S	3	2702264	33.1	0 - 1.56	3.94	9.96	17.09	2.95	8.74	3.07	2.36	-	0.79
IP10S	4.5	2702266	33.1	0 - 2.00	3.94	9.96	17.09	2.95	8.94	3.23	2.56	-	0.79
IP10S	6	2702268	51.8	0 - 2.00	4.96	11.89	20.35	3.15	11.50	3.31	3.74	1.57	0.79
IP10S	9	2702270	60.6	0 - 2.00	4.96	12.80	21.42	3.15	12.20	3.70	4.09	1.73	0.98
IP10S	12	2702278	108	0 - 2.13	6.30	15.43	22.60	3.15	17.05	4.76	5.39	1.61	0.98
<b>For very hard materials - with fixed hoisting eye</b>													
IP10H	0.5	2702174	3.97	0 - 0.63	1.73	5.12	8.15	1.57	4.53	1.65	1.10	-	0.43
IP10H	0.75	2702162	4.85	0 - 0.81	1.77	5.47	8.62	1.57	5.12	1.10	1.50	-	0.43
IP10H	1.0	2702176	16.8	0 - 1.38	3.07	7.91	12.99	2.76	7.40	2.52	2.17	-	0.63
IP10H	2.0	2702164	30.4	0 - 1.56	3.94	9.96	17.09	2.95	8.74	3.07	2.36	-	0.79
IP10H	3.0	2702166	33.1	0 - 1.56	3.94	9.96	17.09	2.95	8.94	3.23	2.56	-	0.79
IP10H	4.5	2702168	51.8	0 - 2.00	4.96	11.89	20.35	3.15	11.50	3.31	3.74	1.57	0.79
IP10H	6.0	2702170	60.6	0 - 2.00	4.96	12.80	21.42	3.15	12.20	3.62	4.13	1.73	0.98
IP10H	25.0	2703530	163	0 - 2.36	6.65	1.57	-	1.85	7.24	12.60	8.66	0.98	3.43

\* Design Factor based on EN 13155 and ASME B30.20.

Model IP10 available in 40t, 55t and 100t on request.

Model IP10R (remote control opening and closing via a cable) available on request.

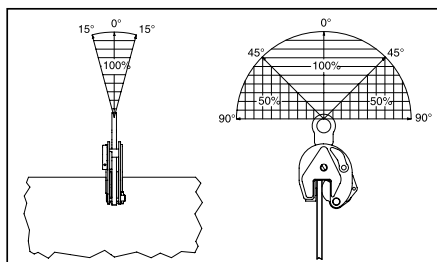

Crosby Lifting Clamps





**IPNM10N**

The IPNM10N vertical lifting clamp is used for lifting, turning, moving or vertical transfer of sheet, plates, or fabrications from horizontal to vertical and down to horizontal (180°) as needed without marring the surface of the material. Materials such as aluminum, stainless steel, painted materials, aircraft skins, composite material, glass, plastic, etc., can be lifted without marring.

**Will not mar, or scratch the material surface.**

**For use in almost all sectors of industry where, during the lift or transfer, no damage to the material is permitted.**

- Available in capacities of .5 , 1 and 2 metric tons.
- Wide variety of jaw openings available: 0" to 1.57"
- Welded alloy steel body for strength and smaller size. Forged alloy components, where required.
- Individually Proof Tested to 2 times the Working Load Limit with certification.
- Company name (CrosbyIP), logo, Working Load Limit and jaw opening permanently stamped on body.
- Each product is individually serialized, with the serial number and Proof Load test date stamped on body. User manual with test certificate is included with each clamp.
- Full 180° turning range for material transfer, turning or moving.
- Lock open, lock closed ability with latch for pretension on material and then release of material.
- Optional IP-5000 Stinger assembly available (see page 428). Allows for easy connection between the clamp and hoist hook.
- Material must be clean and dry.
- Maintenance replacement kits are available.
- Manufactured by an ISO 9001 facility.
- All sizes are **RFID EQUIPPED**.



**IPNM10P**

The IPNM10P vertical lifting clamp is used for lifting, turning, moving or vertical transfer of sheet, plates, or fabrications from horizontal to vertical and down to horizontal (180°) as needed without marring the surface of the material. Materials such as aluminum, stainless steel, painted materials, aircraft skins, composite material, glass, plastic, etc., can be lifted without marring. The protective cover reduces the risk of damage to surrounding plates.

**Will not mar, or scratch the material surface.**



**Load Rated**

## Model IPNM10

Model	Working Load Limit (t)*	IPNM10 Stock No.	Weight Each (lb)	Dimensions (in)								
				Jaw A	B	C	D	E	F	G	H	K
IPNM10N	0.5	2703811	5.95	0 - 0.38	3.31	6.26	9.25	1.57	5.04	2.36	1.61	0.43
IPNM10N	1	2703738	9.70	0 - 0.81	3.82	8.23	10.94	1.57	7.24	3.15	2.20	0.43
IPNM10	2	2703442	32.0	0 - 1.56	6.02	10.16	15.59	2.76	11.65	3.94	6.34	0.63
<b>With protection cap</b>												
IPNM10P	0.5	2703278	6.17	0 - 0.38	3.23	6.18	8.70	1.57	5.71	2.68	1.89	0.43
IPNM10P	1	2703279	9.92	0 - 0.81	3.82	7.68	10.87	1.57	8.07	3.23	2.60	0.43
<b>With larger jaw opening</b>												
IPNM10NJ	1	2703814	10.4	0.81 - 1.44	3.82	8.66	12.64	1.57	7.87	3.15	2.20	0.43
IPNM10NJ1	1	2703819	12.1	0 - 1.00	3.82	9.37	13.82	1.57	8.39	3.15	2.48	0.43

\* Design Factor based on EN 13155 and ASME B30.20.

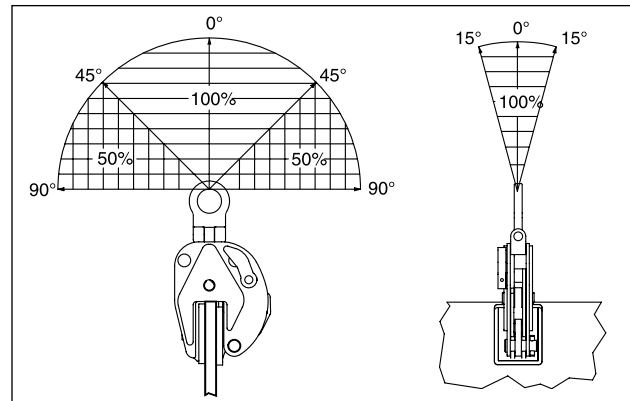
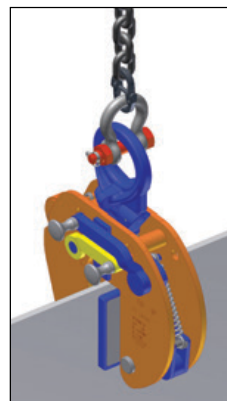
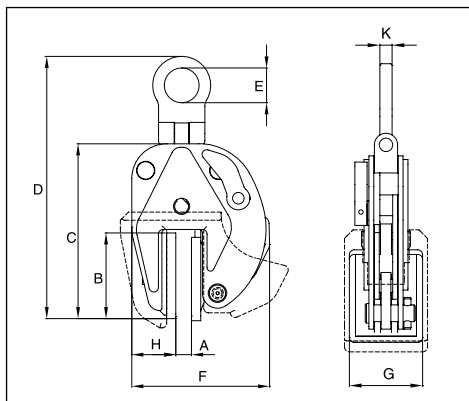

# Vertical Clamps



**IPU10A**

The IPU10A automatically clicks on to the material as soon as the clamp is placed on the plate. The fact that the safety lock remains in position as the clamp closes precludes hazardous situations. Fastening the IPU10A clamp in places that are difficult to reach is no problem.

## For vertical transport of plates

- Available in capacities of 1 and 2 metric tons.
- Jaw openings available: 0" to 1.97".
- Welded alloy steel body for strength and smaller size. Forged alloy components where required.
- Individually Proof Tested to 2 times the Working Load Limit with certification
- Company name (CrosbyIP), logo, Working Load Limit and jaw opening permanently stamped on body.
- Each product is individually serialized, with the serial number and Proof Load test date stamped on body. User manual with test certificate is included with each clamp.
- Available in a variety of styles: Full 180° turning range for material transfer, turning or moving.
- Lock open, lock closed ability with latch for pretension on material and then release of material.
- Optional IP-5000 Stinger assembly available (see page 428). Allows for easy connection between the clamp and hoist hook.
- Minimum WLL of 10% of Maximum WLL.
- Maintenance replacement parts are available.
- Manufactured by an ISO 9001 facility.
- All sizes are **RFID EQUIPPED**.

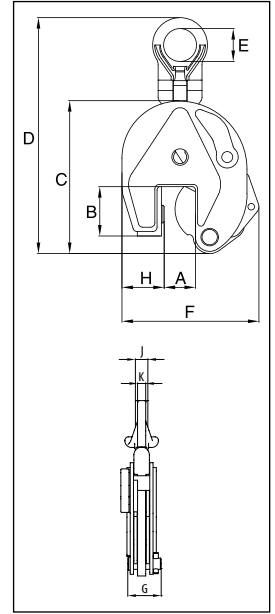

**Load Rated**

## Model IPU10A

Model	Working Load Limit (t)*	IPU10A Stock No.	Weight Each (lb)	Dimensions (in)									
				Jaw A	B	C	D	E	F	G	H	J	K
IPU10A	1	2701628	5.07	0 - 0.81	1.77	5.47	8.86	1.57	5.00	1.65	1.50	-	0.43
IPU10A	2	2701629	18.5	0 - 1.38	3.07	7.91	14.49	2.76	7.40	2.52	2.17	-	0.63
IPU10A	6	2701638	56.0	0 - 2.00	4.96	11.89	20.67	3.15	11.50	3.31	3.74	1.73	0.79

\* Design Factor based on EN 13155 and ASME B30.20.

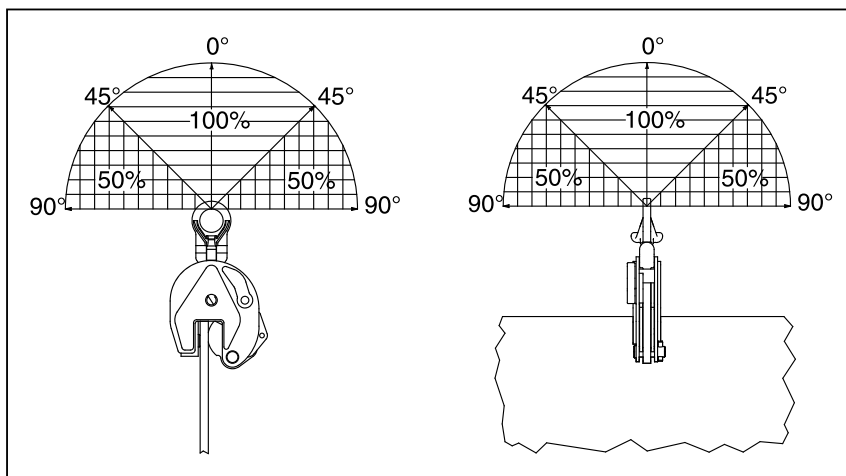

Crosby Lifting Clamps



**IPHNM10**

The IPHNM10 horizontal lifting clamps have a pretension feature that allows the user to attach the clamps to the material for horizontal lifting and transfer of non-sagging material. To be used where material surface must not be damaged. These clamps must be used in pairs or more.

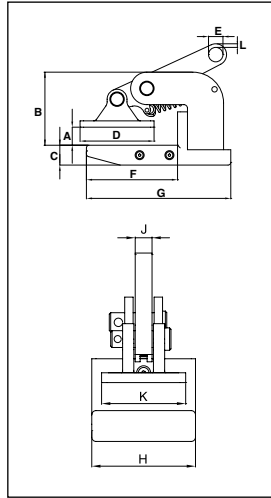

**IPH10**

The IPH10 horizontal lifting clamps with spring loaded tension have a pretension feature that allows the user to attach the clamps to the material for horizontal lifting and transfer of non-sagging material. These clamps must be used in pairs or more.

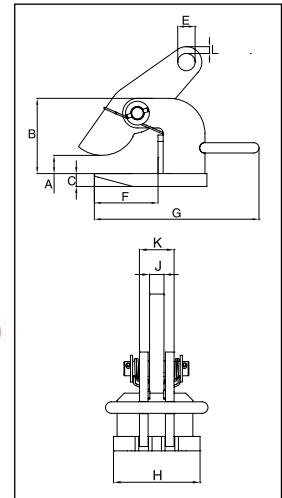

**For Horizontal Lift and Transfer with Pretension System**

- Available in capacities of .5 thru 12 metric tons.
- Jaw openings available: 0" to 4.75".
- Welded alloy steel body for strength and smaller size. Forged alloy components, where required.
- Individually Proof Tested to 2 times the Working Load Limit with certification.
- Company name (Crosby/IP), logo, Working Load Limit and jaw opening permanently stamped on body.
- Each product is individually serialized, with the serial number and Proof Load test date stamped on body. User manual with test certificate is included with each clamp.
- Maintenance and repair kits are available.
- Manufactured by an ISO 9001 facility.
- All sizes are **RFID EQUIPPED**.



**Load Rated®**

**Model IPHNM10**

Model	Working Load Limit (Per Pair) (t)*	IPHNM10 Stock No.	Weight Each (lb)	Dimensions (in)										
				Jaw A	B	C	D	E	F	G	H	J	K	L
IPHNM10	.5	2703287	8.00	0 - 0.81	3.19	0.87	3.23	0.63	3.98	6.30	2.91	0.47	2.36	0.16
IPHNM10	1	2703288	14.0	0 - 1.38	3.66	1.18	3.62	0.63	4.06	6.46	2.91	0.47	2.36	0.28
IPHNM10	2	2703290	32.0	0 - 1.18	5.47	1.18	5.16	0.87	6.54	9.65	3.94	0.79	2.91	0.35
IPHNM10J	2	2703291	34.0	1.19 - 2.38	6.65	1.18	5.16	0.87	6.54	9.65	3.94	0.79	2.91	0.35

\* Design Factor based on EN 13155 and ASME B30.20.

**Model IPH10 and IPH10J: With Spring Loaded Tension, Magnets and Handle**

Model	Working Load Limit (Per Pair) (t)*	IPH10 Stock No.	Weight Each (lb)	Dimensions (in)										
				Jaw A	B	C	E	F	G	H	J	K	L	
IPH10	.5+	2703297	3.97	0 - 0.81	3.39	0.47	0.63	4.06	5.91	2.36	0.47	1.06	0.16	
IPH10	1+	2703298	5.50	0 - 1.38	3.94	0.63	0.63	4.06	5.91	2.36	0.47	1.22	0.28	
IPH10	2	2703522	24.3	0 - 2.38	4.61	0.63	0.87	4.29	10.08	4.33	0.79	1.57	0.35	
IPH10	3	2703523	33.1	0 - 2.38	4.61	0.79	1.02	4.29	10.47	4.72	0.79	1.89	0.43	
IPH10	4.5	2703524	46.3	0 - 2.38	5.20	0.98	1.18	4.09	11.02	5.12	0.79	1.89	0.47	
IPH10	6	2703525	57.3	0 - 2.38	5.63	0.98	1.42	4.84	12.60	5.12	0.79	1.89	0.55	
IPH10	9	2703526	81.6	0 - 2.38	6.18	1.18	1.69	5.24	12.99	5.51	0.98	2.44	0.63	
IPH10	12	2703527	94.8	0 - 2.38	6.77	1.18	1.85	5.55	13.90	5.91	0.98	2.44	0.67	

**With larger jaw opening #**

IPH10J	3	2703533	38.0	2.38 - 4.75	6.97	0.79	1.02	4.29	10.47	4.72	0.79	1.89	0.35
IPH10J	4.5	2703534	52.0	2.38 - 4.75	7.56	0.98	1.18	4.09	11.02	5.12	0.79	1.89	0.43
IPH10J	6	2703535	66.0	2.38 - 4.75	7.99	0.98	1.42	4.84	12.60	5.12	0.79	1.89	0.47
IPH10J	9	2703536	90.0	2.38 - 4.75	8.54	1.18	1.69	5.24	12.99	5.51	0.98	2.44	0.55
IPH10J	12	2703537	90.0	2.38 - 4.75	9.13	1.18	1.85	5.55	13.90	5.91	0.98	2.44	0.63

\* Design Factor based on EN 13155 and ASME B30.20. + No handle or magnets. # Larger Working Load Limits available.

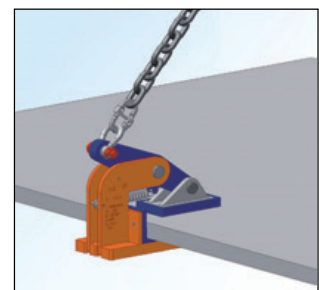
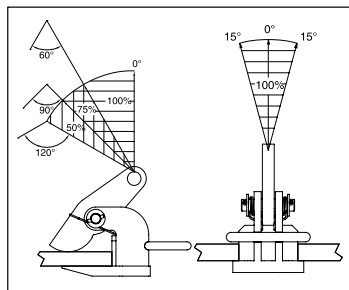
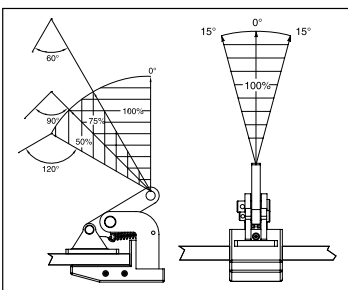

# Horizontal Clamps



**IPH10E**

The IPH10E / IPH10JE horizontal lifting clamps are for use in the lifting and transfer in horizontal position of non-sagging materials or of bundles of non-sagging material. These clamps must be used in pairs or more.

## For horizontal lifting and transfer

- Available in capacities of 2.0 thru 25 metric tons.
- Wide variety of jaw openings available: 0 to 4.72”
- Welded alloy steel body for strength and smaller size. Forged alloy, components where required.
- Equipped with handle for easy placement.
- Individually Proof Tested to 2 times the Working Load Limit with certification.
- Company name (CrosbyIP), logo, Working Load Limit and jaw opening permanently stamped on body.
- Each product is individually serialized, with the serial number and Proof Load test date stamped on body. User manual with test certificate is include with each clamp.
- Maintenance and repair spare kits are available.
- Manufactured by an ISO 9001 facility.
- All sizes are **RFID EQUIPPED**.

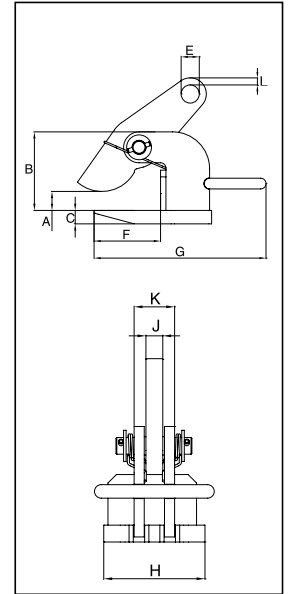

## Model IPH10E: Jaw opening range 0 to 2.38”

Model	Working Load Limit (Per Pair) (t)*	IPH10E Stock No.	Weight Each (lb)	Dimensions (in)									
				Jaw A	B	C	E	F	G	H	J	K	L
IPH10E	2	2703542	24.0	0 - 2.38	4.61	0.63	0.87	4.29	10.08	4.33	0.79	1.57	0.35
IPH10E	3	2703543	32.0	0 - 2.38	4.61	0.79	1.02	4.29	10.47	4.72	0.79	1.89	0.43
IPH10E	4.5	2703544	46.0	0 - 2.38	5.20	0.98	1.18	4.09	11.02	5.12	0.79	1.89	0.47
IPH10E	6	2703545	56.0	0 - 2.38	5.63	0.98	1.42	4.84	12.60	5.12	0.79	1.89	0.55
IPH10E	9	2703546	80.0	0 - 2.38	6.18	1.18	1.69	5.24	12.99	5.51	0.98	2.44	0.63
IPH10E	12	2703547	94.0	0 - 2.38	6.77	1.18	1.85	5.55	13.90	5.91	0.98	2.44	0.67
IPHTOZ	25	2705119	86.0	0 - 2.38	6.65	1.57	1.85	6.69	11.81	8.66	1.26	4.45	.85

\* Design Factor based on EN 13155 and ASME B30.20.

## Model IPH10JE: Jaw opening range 2.36 to 4.72”

Model	Working Load Limit (Per Pair) (t)*	IPH10JE Stock No.	Weight Each (lb)	Dimensions (in)									
				Jaw A	B	C	E	F	G	H	J	K	L
IPH10JE	3	2703553	38.0	2.38 - 4.75	6.97	0.79	1.02	4.29	10.47	4.72	0.79	1.89	0.43
IPH10JE	4.5	2703554	52.0	2.38 - 4.75	7.56	0.98	1.18	4.09	11.02	5.12	0.79	1.89	0.47
IPH10JE	6	2703555	66.0	2.38 - 4.75	7.99	0.98	1.42	4.84	12.60	5.12	0.79	1.89	0.55
IPH10JE	9	2703556	90.0	2.38 - 4.75	8.54	1.18	1.18	5.24	12.99	5.51	0.98	2.44	0.63
IPH10JE	12	2703557	104.0	2.38 - 4.75	9.13	1.18	1.85	5.55	13.90	5.91	0.98	2.44	0.67

\* Design Factor based on EN 13155 and ASME B30.20.

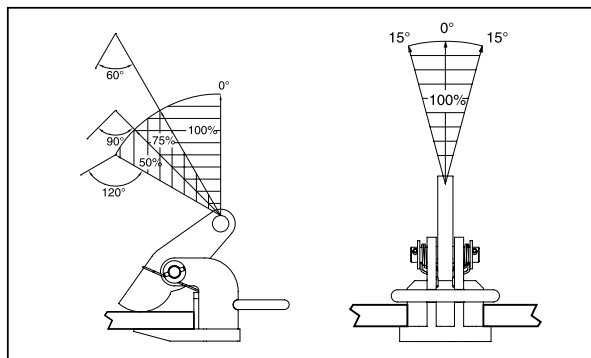





IPHOZ

The IPHOZ horizontal lifting clamp is to be used for lifting and transferring, in the horizontal position, of thin sheet and other materials that will sag or bend when lifted. These clamps must be used in pairs or more.

**For Horizontal Lifting and Transfer**

- Available in capacities of .75 thru 15 metric tons.
- Wide variety of jaw openings available: 0" to 2.36".
- Welded alloy steel body for strength and smaller size. Forged alloy, components where required.
- Equipped with handle for easy placement.
- Individually Proof Tested to 2 times the Working Load Limit with certification.
- Company name (CrosbyIP), logo, Working Load Limit and jaw opening permanently stamped on body.
- Each product is individually serialized, with the serial number and Proof Load test date stamped on body. User manual with test certificate is included with each clamp.
- Maintenance and repair kits are available.
- Manufactured by an ISO 9001 facility.
- All sizes are **RFID EQUIPPED**.

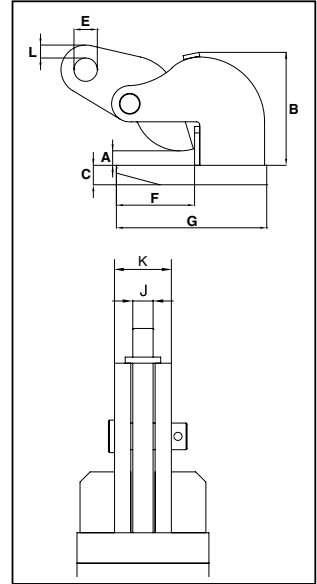

Load Rated®

**Model IPHOZ: Jaw opening range 0 to 2.36"**

Model	Working Load Limit (Per Pair) (t)*	IPHOZ Stock No.	Weight Each (lb)	Dimensions (in)									
				Jaw A	B	C	E	F	G	H	J	K	L
IPHOZ	0.75	2705401	12.0	0 - 1.19	3.70	0.63	0.63	2.76	4.65	3.19	0.47	1.22	0.47
IPHOZ	1.5	2705402	24.0	0 - 1.75	5.24	0.63	0.87	4.92	7.56	3.94	0.63	1.42	0.47
IPHOZ	3	2705403	34.0	0 - 1.75	5.39	0.79	1.02	4.92	7.87	4.72	0.79	1.89	0.39
IPHOZ	4.5	2705404	36.0	0 - 1.75	5.43	0.98	1.18	4.96	8.66	4.72	0.79	1.97	0.39
IPHOZ	6	2705405	68.0	0 - 2.38	6.73	1.18	1.42	5.31	9.25	5.12	0.79	2.20	0.79
IPHOZ	9	2705406	90.0	0 - 2.38	8.31	1.18	1.69	6.54	10.87	6.30	0.98	2.44	0.79
IPHOZ	12	2705407	122	0 - 2.38	8.54	1.57	1.85	6.61	11.57	7.48	0.98	2.44	0.75
IPHOZ	15	2705408	158	0 - 2.38	8.66	1.57	1.85	7.20	12.48	9.84	0.98	2.44	0.87

\* Design Factor based on EN 13155 and ASME B30.20.

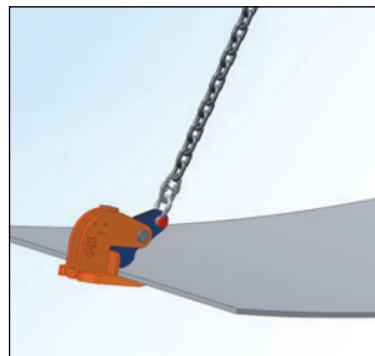
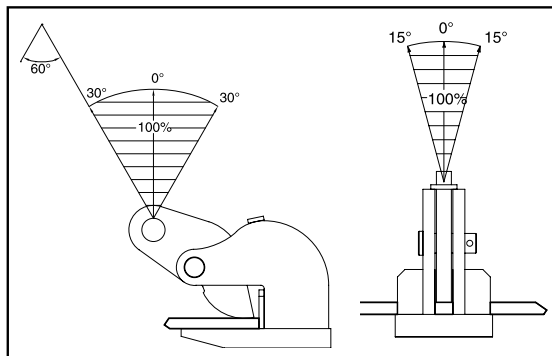

# Horizontal Clamps



## IPBC

The IPBC horizontal lifting clamps have a pretension feature that allows the user to attach the clamps to the material for horizontal lifting and transfer of sagging and non-sagging material. These clamps may also be used to handle material that will be used in shears, bending and rolling machines or other fabrication equipment. May also be used for turning beams from the "H" into the "I" position.

## For Horizontal Transfer - with Pretension System

- Available in capacities of 1 thru 4.5 metric tons.
- Jaw openings available: 0" to 1.57".
- Welded alloy steel body for strength and smaller size. Forged alloy, components where required.
- Equipped with handle for easy placement.
- Individually Proof Tested to 2 times the Working Load Limit with certification.
- Company name (CrosbyIP), logo, Working Load Limit and jaw opening permanently stamped on body.
- Each product is individually serialized, with the serial number and Proof Load test date stamped on body. User manual with test certificate is included with each clamp
- Maintenance and repair kits are available.
- Manufactured by an ISO 9001 facility.
- All sizes are **RFID EQUIPPED**.



## IPHGZ

The IPHGZ, IPHGZU horizontal lifting clamps have a pretension locking feature that allows the user to attach the clamps to the material for horizontal lifting and transfer of sagging and non-sagging material. These clamps may also be used to handle material that will be used in shears, bending and rolling machines or other fabrication equipment. May also be used to move and lift structural shapes such as I-Beams, H-beams etc.



**Load Rated**

## Model IPBC

Model	Working Load Limit (t)*	IPBC Stock No.	Weight Each (lb)	Dimensions (in)									
				Jaw A	B	C	E	F	G	H	J	K	L
IPBC	1	2700410	7.72	0 - 0.81	5.20	2.05	1.02	2.95	7.28	1.42	0.63	7.17	0.47
IPBC	2	2700411	14.3	0 - 1.00	5.98	2.44	1.18	3.23	8.27	1.93	0.79	8.58	0.59
IPBC	3	2700412	18.8	0 - 1.00	6.18	2.60	1.18	3.23	8.27	2.24	0.79	8.86	0.59

\* Design Factor based on EN 13155 and ASME B30.20.

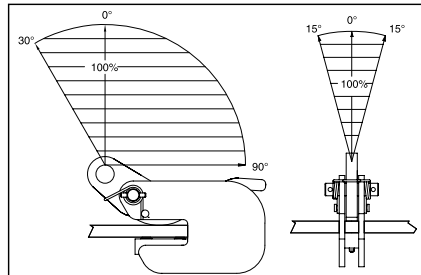
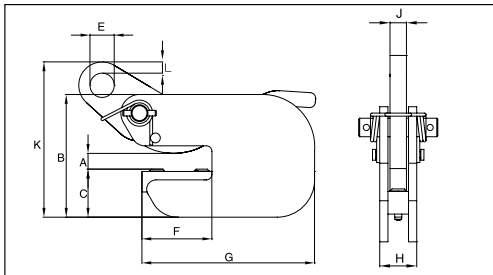

## Model IPHGZ: Universal Lifting Eye / Model IPHGZU: Fixed Hoisting Eye

Model	Working Load Limit (t)*	IPHGZU Stock No.	Weight Each (lb)	Dimensions (in)								
				Jaw A	B	C	D	E	F	G	J	K
IPHGZU	1.5	2705455	19.8	0 - 1.00	4.33	9.13	11.30	2.76	5.47	3.54	0.79	0.63
IPHGZU	3.0	2705456	43.9	0 - 1.56	4.69	9.96	13.70	2.95	6.89	4.72	0.98	0.79
IPHGZU	4.5	2705457	66.1	0 - 1.56	4.69	11.85	14.57	3.15	6.89	6.10	1.18	1.73
Fixed Hoisting Eye												
IPHGZ	.75	2705451	8.82	0 - 1.00	3.23	5.83	8.11	1.97	3.90	3.86	0.47	0.87
IPHGZ	1.5	2705452	4.41	0 - 1.00	4.33	7.87	9.84	1.97	4.65	3.54	0.79	1.10
IPHGZ	3.0	2705453	27.1	0 - 1.56	4.72	8.94	12.01	2.76	5.83	4.72	0.98	1.26
IPHGZ	4.5	2705454	55.1	0 - 1.56	4.72	11.18	15.00	2.76	7.13	6.10	1.18	1.57

\* Design Factor based on EN 13155 and ASME B30.20.

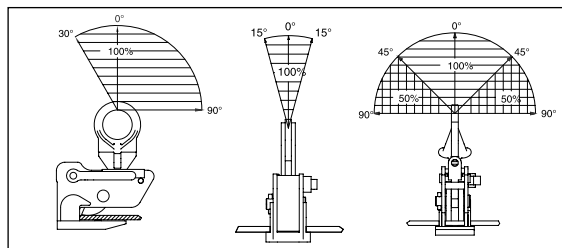
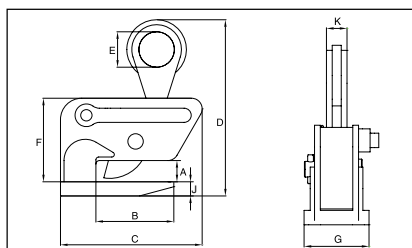



**IPPE10B(E)**

The IPPE10 type clamp is suitable for lifting and transferring bundles of non-bendable sheets of metal in a horizontal position. The jaw opening can be easily adjusted for the height of the bundle or plate. The IPPE10 has magnets in the footplate. This allows one person to operate multiple clamps at the same time when lifting loads.

**For lifting and transporting non-bendable sheet metal in a horizontal position.**

- Available in capacities of 3 thru 12 metric tons.
- Wide variety of jaw openings available: 0 to 7.09".
- Welded alloy steel body for strength and smaller size. Forged alloy components, where required.
- Individually Proof Tested to 2 times the Working Load Limit with certification.
- Company name (CrosbyIP), logo, Working Load Limit and jaw opening permanently stamped on body.
- Each product is individually serialized, with the serial number and Proof Load test date stamped on body. User manual with test certificate is included with each clamp
- Maintenance and repair kits are available.
- Manufactured by an ISO 9001 facility.
- All sizes are **RFID EQUIPPED**.
- IPPE10B: Magnets in foot plate (also applies for D and H Type).
- IPPE10BE: Economic version (also applies for D and H-Type).
- IPPE10BNM: Non-marring (also applies for D and H-Type).



**IPPE10BNM**

The IPPE10BNM lifting clamps may be used for virtually all applications, where the objects that are to be lifted or transported require optimal protection against surface damage. This also applies to materials with a very smooth surface, composites, plates with a protective cover or hard surface plates. These clamps have to be used in pairs.



**Model IPPE10B / IPPE10BE / IPPE10BNM**

Model	IPPE Stock No.	Working Load Limit (Per Pair) (t)*	Weight Each (lb)	Dimensions (in)									
				Jaw A	B	C	D	E	F	G	H	J	L
3 IPPE10B	2703862	3.0	50.0	0 - 7.13	8.03	12.68	0.79	1.02	2.60	0.79	3.94	1.97	0.59
6 IPPE10B	2703871	6.0	70.0	0 - 7.13	8.66	13.39	0.98	1.18	2.91	0.79	5.51	2.36	0.51
9 IPPE10B	2703888	9.0	108	0 - 7.13	9.76	14.37	0.98	1.34	3.54	0.79	7.48	2.76	0.51
12 IPPE10B	2703921	12.0	144	0 - 7.13	9.92	14.80	1.18	1.57	3.54	0.98	7.87	2.76	0.71
3 IPPE10BE	2703863	3.0	94	0 - 7.13	8.03	12.68	0.79	1.02	2.60	0.79	3.94	1.97	0.59
6 IPPE10BE	2703870	6.0	70	0 - 7.13	8.66	13.39	0.98	1.18	2.91	0.79	5.51	2.36	0.51
9 IPPE10BE	2703891	9.0	108	0 - 7.13	9.76	14.37	0.98	1.34	3.54	0.79	7.48	2.76	0.51
12 IPPE10BE	2703924	12.0	144	0 - 7.13	10.31	14.80	1.18	1.57	3.54	0.98	7.87	2.76	0.71
3 IPPE10BNM	2703864	3.0	54	0 - 7.13	8.03	12.68	1.18	1.02	2.68	0.79	3.94	1.97	0.59
6 IPPE10BNM	2703872	6.0	76	0 - 7.13	8.66	13.39	1.38	1.18	2.99	0.79	5.51	2.36	0.51
9 IPPE10BNM	2703894	9.0	122	0 - 7.13	9.76	14.37	1.38	1.34	3.62	0.79	7.48	2.76	0.51
12 IPPE10BNM	2703927	12.0	154	0 - 7.13	10.31	14.80	1.57	1.57	3.62	0.98	7.87	2.76	0.59

\* Design Factor based on EN 13155 and ASME B30.20. Also available in D-Type (maximum jaw opening of 11.75") and H-Type (maximum jaw opening of 16.50").

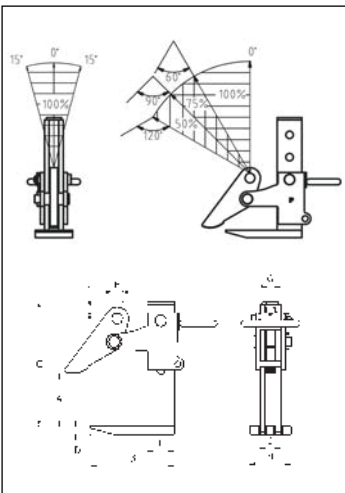

**IPPE10(E)**

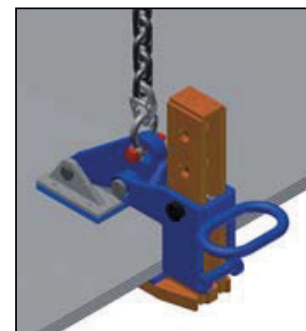
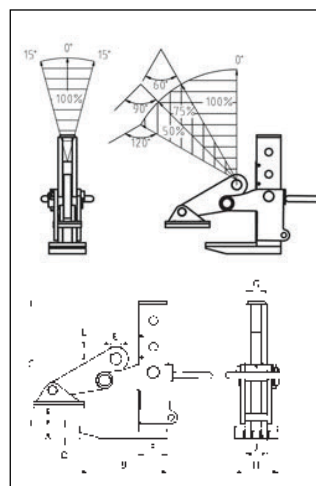

**IPPE10BNM**

# Beam Clamps



**IPBK10**

The IPBK10 beam clamp is used for lifting, transferring and stacking H-Beams. A ring-center hoist eye allows for the beam flange to remain vertical. This series of clamps can be used in vertical and horizontal moving, transferring and stacking of different types of structural designs, such as H-Beams, angles, etc, depending on the application desired.

## For the transfer and stacking of steel beams

- IPVUZ / IPVZ: Available in capacities of 0.75 thru 1.5 metric tons.
- IPVUZ / IPVZ: Jaw openings available: 0 to 0.79".
- IPBK10: Available in capacities of 0.5 thru 4 metric tons.
- IPBK10: Jaw openings available: 0.2 to 1.1".
- Welded alloy steel body for strength and smaller size. Forged alloy components, where required.
- Individually Proof Tested to 2 times the Working Load Limit with certification.
- Company name (CrosbyIP), logo, Working Load Limit and jaw opening permanently stamped on body.
- Each product is individually serialized, with the serial number and Proof Load test date stamped on body. User manual with test certificate is included with each clamp.
- Optional IP-5000 Stinger assembly available (see page 428). Allows for easy connection between the clamp and hoist hook.
- Minimum WLL of 10% of Maximum WLL.
- Maintenance and repair kits are available.
- For use with materials with a plate surface hardness to 279HV10, only 5% min WLL is needed.
- Manufactured by an ISO 9001 facility.
- All sizes are **RFID EQUIPPED**.



**IPVUZ**

The IPVZ / IPVUZ beam clamp is used for vertical lift and transfer of angle iron and other loads that have only a small gripping area for the clamp ("U" has universal hoisting eye). This series of clamps can be used in vertical and horizontal moving, transferring and stacking of different types of structural designs, such as H-beams, angles, etc, depending on the application desired.



**Load Rated**

## Model IPBK10

Model	Working Load Limit (t)*	IPBK10 Stock No.	Weight Each (lb)	Dimensions (in)								
				Jaw A	B	C	D	E	F	G	H	J
0.5 IPBK10	0.5	2703931	5.29	0.19 - 0.63	1.69	5.28	8.50	1.77	4.72	1.89	1.77	0.39
1 IPBK10	1.0	2703837	5.73	0.19 - 0.63	1.69	5.98	9.06	1.77	4.84	1.85	1.77	0.39
2 IPBK10	2.0	2703838	16.1	0.19 - 1.00	2.44	8.78	13.43	2.76	7.80	2.40	2.76	0.63
4 IPBK10	4.0	2703839	37.3	0.19 - 1.13	2.95	11.10	16.97	3.94	9.13	3.07	2.83	0.79

\* Design Factor based on EN 13155 and ASME B30.20.

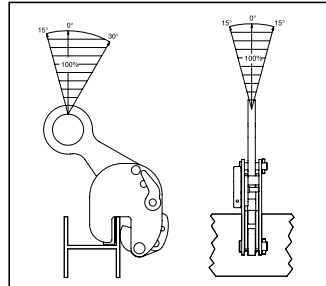
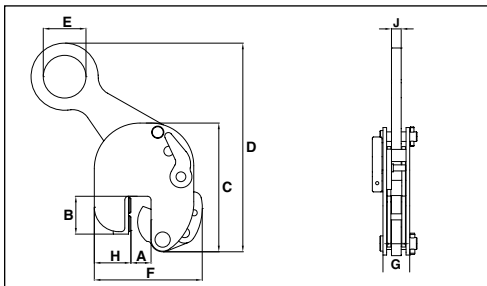

## Model IPVUZ: Universal Hoisting Eye / Model IPVZ: Fixed Hoisting Eye

Model	Working Load Limit (t)*	IPVUZ Stock No.	Weight Each (lb)	Dimensions (in)								
				Jaw A	B	C	D	E	F	G	H	K
IPVUZ	0.75	2705146	3.97	0 - 0.63	1.02	5.12	8.50	1.57	4.53	1.65	1.18	0.43
IPVUZ	1.5	2705147	15.21	0 - 0.81	2.17	7.87	14.88	2.76	7.87	2.40	2.52	0.63
Fixed Hoisting Eye												
IPVZ	0.75	2705096	3.75	0 - 0.63	1.02	5.12	7.99	1.57	4.53	1.65	1.18	0.43
IPVZ	1.5	2705097	13.01	0 - 0.81	2.17	7.87	13.35	2.76	7.09	2.40	2.52	0.63

\* Design Factor based on EN 13155 and ASME B30.20.

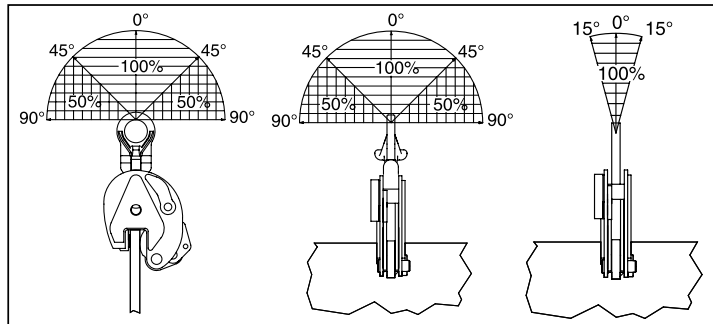
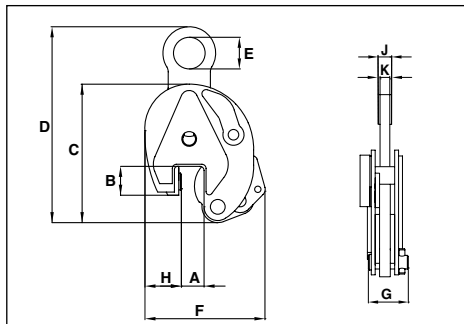

Crosby Lifting Clamps





**IPBHZ**

The IPBHZ beam clamp is used for lifting, transferring and stacking H-Beams. An ring-center hoist eye allows for the beam flange to remain vertical. This series of clamps can be used in vertical and horizontal moving, transferring and stacking of different types of structural designs, such as H-Beams, angles, etc. depending on the application desired.

**For the lifting and transfer of steel beams**

- IPBHZ: Available in capacities of .75 thru 12 metric tons.
- IPBHZ: Wide variety of jaw openings available: 0 to 1.57”.
- IPBSNZ: Available in capacities of 1.5 thru 4.5 metric tons.
- IPBSNZ: Wide variety of jaw openings available: 0 to 2.00”.
- Welded alloy steel body for strength and smaller size. Forged alloy components, where required.
- Individually Proof Tested to 2 times the Working Load Limit with certification.
- Company name (CrosbyIP), logo, Working Load Limit and jaw opening permanently stamped on body.
- Each product is individually serialized, with the serial number and Proof Load test date stamped on body. User manual with test certificate is included with each clamp.
- Optional IP-5000 Stinger assembly available (see page 428). Allows for easy connection between the clamp and hoist hook.
- Minimum WLL of 10% of Maximum WLL.
- Maintenance and repair kits are available.
- Manufactured by an ISO 9001 facility.
- All sizes are **RFID EQUIPPED**.



**IPBSNZ**

The IPBSNZ beam clamp is used for lifting, transferring and stacking H-Beams. An ring-center hoist eye allows for the beam flange to remain vertical. This series of clamps can be used in vertical and horizontal moving, transferring and stacking of different types of structural designs, such as H-Beams, angles, etc. depending on the application desired.



**Load Rated**

**Model IPBHZ**

Model	Working Load Limit (t)*	IPBHZ Stock No.	Weight Each (lb)	Dimensions (in)								
				Jaw A	B	C	D	E	F	G	J	K
IPBHZ	0.75	2705461	6.61	0 - 1.00	1.57	5.83	8.66	1.97	5.12	2.72	1.30	0.87
IPBHZ	1.5	2705462	13.2	0 - 1.00	2.36	7.99	10.04	1.97	6.22	2.87	1.38	1.10
IPBHZ	3	2705463	23.2	0 - 1.56	3.15	8.94	12.80	2.76	7.40	4.41	1.50	1.26
IPBHZ	4.5	2705464	55.1	0 - 1.56	4.41	11.18	16.26	2.76	9.88	4.57	3.15	1.57
IPBHZ	12	2705467	93.3	0 - 1.56	4.92	18.35	19.29	3.54	12.48	3.54	3.54	1.85

\* Design Factor based on EN 13155 and ASME B30.20.

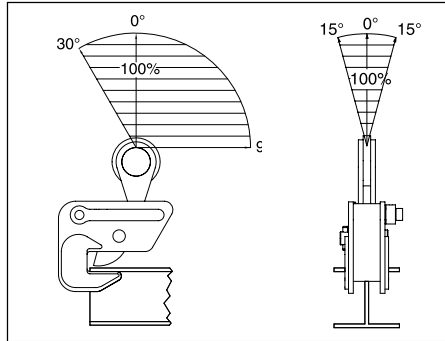
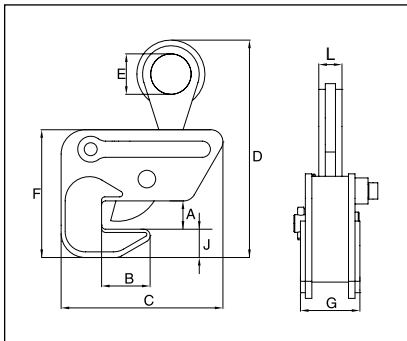

**Model IPBSNZ**

Model	Working Load Limit (t)*	IPBSNZ Stock No.	Weight Each (lb)	Dimensions (in)										
				Jaw A	B	C	D	E	F	G	H	J	K	L
IPBSNZ	1.5	2705925	30.9	0 - 1.25	3.94-10.63	11.97	18.90	2.76	12.56	1.85	0.63	6.50	5.83	9.45
IPBSNZ	3	2705926	48.5	0 - 1.56	3.94-12.99	13.86	19.45	2.95	16.06	2.20	0.79	8.15	7.17	10.24
IPBSNZ	4.5	2705927	67.2	0 - 2.00	3.94-14.17	16.54	24.80	2.95	17.99	2.20	0.79	9.84	7.40	11.54

\* Design Factor based on EN 13155 and ASME B30.20.

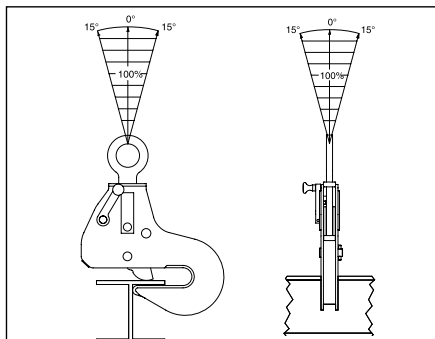
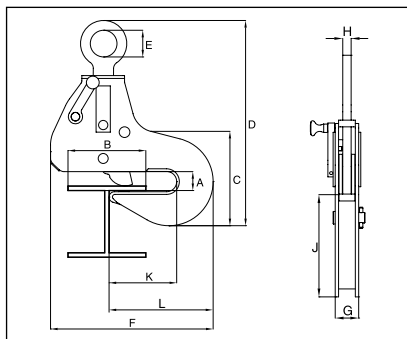

# Beam Clamps

## For transferring steel beams and attaching tackle eye

- Available in capacities of 2 thru 25 metric tons.
- Wide variety of jaw openings available: 2.95" to 40.16"
- Welded alloy steel body for strength and smaller size. Forged alloy components, where required.
- Individually Proof Tested to 2 times the Working Load Limit with certification.
- Company name (CrosbyIP), logo, Working Load Limit and jaw opening permanently stamped on body.
- Each product is individually serialized, with the serial number and Proof Load test date stamped on body. User manual with test certificate is included with each clamp.
- Maintenance and repair kits are available.
- Manufactured by an ISO 9001 facility.
- All sizes are RFID EQUIPPED.

### IPTK

This IPTK series beam clamp is suitable for use as a temporary tackle eye for a beam.



### IPTKW

The IPTKW series beam clamp is suitable for use as a temporary tackle eye for a beam.



**Load Rated**



### IPTKU

The IPTKU series beam clamp has an improved hinged hoisting eye that increases the loading angles and an optional new "Double Locking Device".



### IPTKUM

This anchor clamp is suitable as an anchor device for one person, with a personal fall arrest (sherdised and with double locking) system.

**IPTK: with hoisting eye / IPTKW: without hoisting eye**

**IPTKU: with hinged hoisting eye / IPTKUD: with double locking device**

**IPTKUM: Suitable as anchor device for personnel fall arrest equipment**

Model	Working Load Limit (t)*	IPTK Stock No.	Weight Each (lb)	Dimensions (in)							
				Jaw A	C	D	E	F	H	J	K
IPTK	2	2700996	13.2	2.95 - 7.48	A + 3.13	4.92	2.95	-	0.98	-	0.79
IPTK	3	2700997	14.3	2.95 - 7.48	A + 3.13	4.92	2.95	-	0.98	-	0.79
IPTK	4	2700998	18.7	5.91 - 11.02	A + 4.00	4.92	2.95	-	1.38	-	0.79
IPTK	5	2700994	24.3	4.72 - 13.78	A + 7.67	4.92	2.95	-	1.57	-	0.79
IPTK	25	2702999	496.0	17.72 - 40.16	A + 8.66	19.69	4.92	-	2.99	-	1.77
<b>Without Hoisting Eye</b>											
IPTKW	2	2700966	8.82	3.00 - 7.50	A + 3.13	4.92	-	1.10	0.98	-	-
IPTKW	3	2700967	9.92	3.00 - 7.50	A + 3.13	4.92	-	1.10	0.98	-	-
IPTKW	4	2700968	13.9	5.88 - 11.25	A + 4.00	4.92	-	1.30	1.38	-	-
IPTKW	5	2700969	19.4	4.75 - 13.75	A + 7.67	4.92	-	1.30	1.57	-	-
<b>With Improved Hinged Hoisting Eye</b>											
IPTKU	2	2707996	12.6	3.00 - 7.50	A + 3.94	A + 3.94	4.76	2.99	0.87	3.90	0.75
IPTKU	3	2707997	14.1	3.00 - 7.50	A + 3.94	A + 3.94	4.76	3.50	0.87	4.80	0.87
IPTKU	4	2707998	26.7	4.75 - 11.25	A + 5.91	A + 5.91	5.51	3.50	1.57	4.80	0.87
IPTKU	5	2707994	32.0	4.75 - 13.75	A + 6.89	A + 6.89	5.51	3.50	1.57	4.80	0.87
IPTKU	10	2707970	90.4	7.88 - 18.00	A + 11.81	A + 11.81	7.87	4.13	2.36	5.98	1.02
<b>Suitable as anchor device for personnel fall arrest equipment - standard according to EN 795</b>											
IPTKUM	1	2709991	13.2	3.00 - 7.50	A + 3.94	6.50	2.99	-	0.87	3.90	0.75
<b>With Optional Double Locking Device</b>											
IPTKUD	2	2709996	13.2	3.00 - 7.50	A + 3.94	6.50	2.99	0.87	0.87	3.90	0.75
IPTKUD	3	2709993	14.6	3.00 - 7.50	A + 3.94	6.50	3.50	0.87	0.87	4.80	0.87
IPTKUD	4	2709995	27.1	4.75 - 11.25	A + 5.91	7.28	3.50	1.57	1.57	4.80	0.87
IPTKUD	5	2709994	33.7	4.75 - 13.75	A + 6.89	7.28	3.50	1.57	1.57	4.80	0.87
IPTKUD	10	2709970	94.8	7.88 - 18.00	A + 11.81	8.46	4.13	2.36	2.36	5.98	1.02

\* Design Factor based on EN 13155 and ASME B30.20.

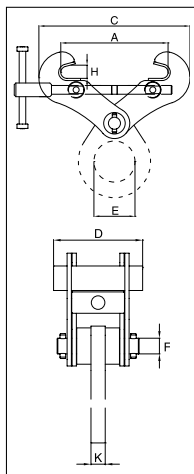

IPTK/IPTKW

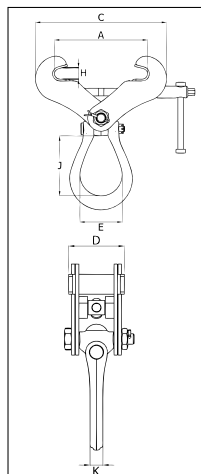

IPTKU(D)(M)

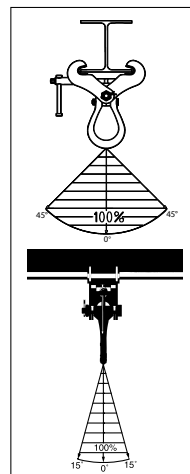

IPTKU(D)

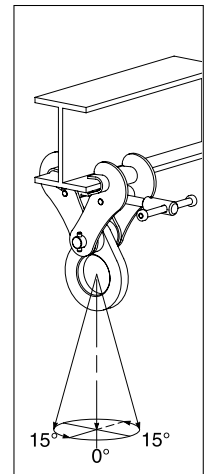

IPTK

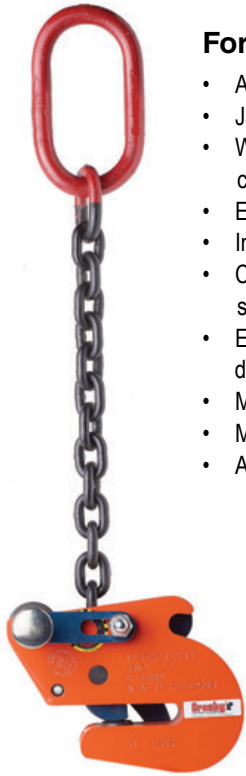

**For Lifting and Transferring Steel Beams**

- Available in capacities of 1.5 and 2.5 metric tons.
- Jaw openings available: .24" to .79".
- Welded alloy steel body for strength and smaller size. Forged alloy, components where required.
- Equipped with handle for easy placement.
- Individually Proof Tested to 2 times the Working Load Limit with certification.
- Company name (CrosbyIP), logo, Working Load Limit and jaw opening permanently stamped on body.
- Each product is individually serialized, with the serial number and Proof Load test date stamped on body. User manual with test certificate is included with each clamp.
- Maintenance replacement parts are available.
- Manufactured by an ISO 9001 facility.
- All sizes are **RFID EQUIPPED**.

**IPSTARTEC11**

The IPSTARTEC11 beam clamp has been specially developed for lifting with the body in vertical position, controlled tilting, transportation and stacking of steel "H" and "I" profiles. By placing the chain guide in the appropriate position, it is easy to switch from lifting to tilting and back again, which shifts the center of gravity.

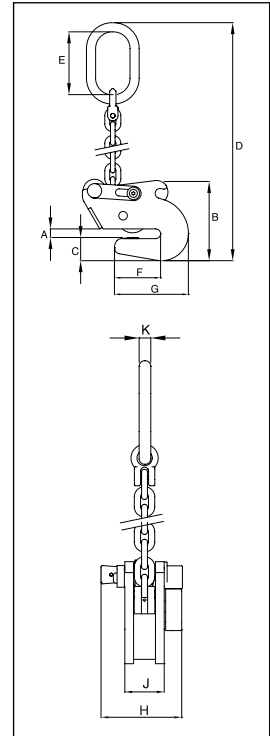

**Load Rated**

**Model IPSTARTEC11**

Model	Working Load Limit (t)*	IPSTARTEC11 Stock No.	Weight Each (lb)	Dimensions (in)									
				Jaw A	B	C	D	E	F	G	H	J	K
IPSTARTEC11	1.5	2701812	14.6	0.25 - 0.50	5.51	1.54	22.64	4.33	3.19	5.08	2.13	4.96	0.63
IPSTARTEC11	2.5	2701822	32.0	0.25 - 0.75	8.27	2.17	28.54	5.31	4.53	7.17	2.91	5.51	0.71

\* Design Factor based on EN 13155 and ASME B30.20.

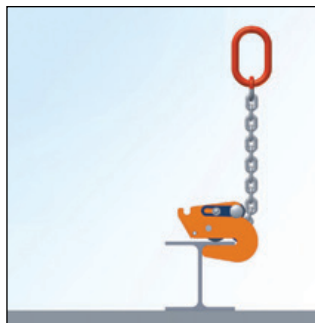
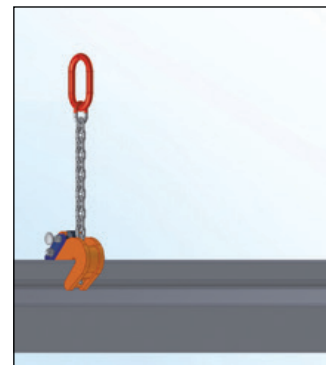
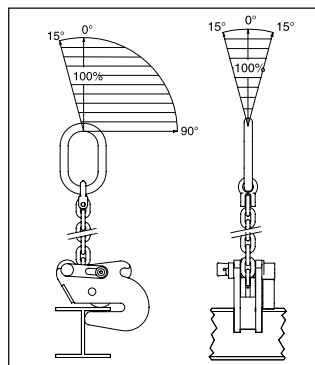

# Drum Clamps



**IPDV**  
The IPDV drum clamp is for vertical lift and transfer. Allows drum to remain in an upright position during the lift and transfer using one clamp.

## Designed to lift, move and transfer 50-55 gallon drums with steel tops

- Available in capacity of .5 metric tons.
- Jaw openings available: IPDV - 11.8" and IPVK - .67".
- Welded alloy steel body for strength and smaller size. Forged alloy components, where required.
- Individually Proof Tested to 2 times the Working Load Limit with certification
- Company name (CrosbyIP), logo, Working Load Limit and jaw opening permanently stamped on body.
- Each product is individually serialized, with the serial number and Proof Load test date stamped on body. User manual with test certificate is included with each clamp
- Maintenance and repair kits are available.
- Manufactured by an ISO 9001 facility.
- IPDV is **RFID EQUIPPED**.

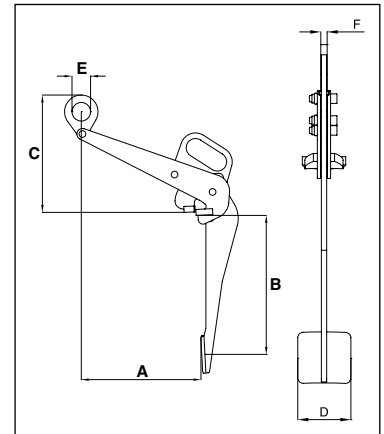

### Model IPDV

Model	Working Load Limit (t)*	IPDV Stock No.	Weight Each (lb)	Dimensions (in)					
				Jaw A	B	C	D	E	F
IPDV	0.5	2700118	15.7	11.75	14.76	11.42	3.94	1.97	0.47

\* Design Factor based on EN 13155 and ASME B30.20.

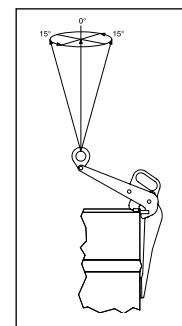

### Model IPVK

Model	Working Load Limit (t)*	IPVK Stock No.	Weight Each (lb)	Dimensions (in)						
				Jaw A	B	C	D	E	G	K
IPVK	0.5	2700116	3.53	0 - 0.63	1.02	5.31	5.20	1.14	2.01	0.43

\* Design Factor based on EN 13155 and ASME B30.20.

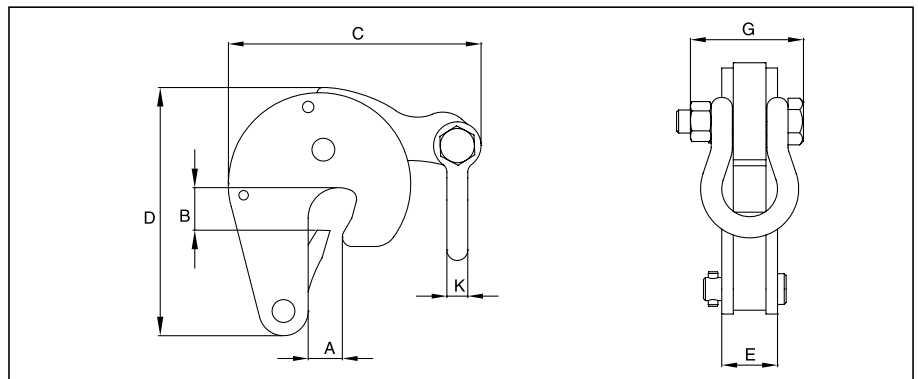

### IPVK

The IPVK drum clamp is for vertical lift and transfer. Automatically locks on drum, and can be used alone or in pairs.

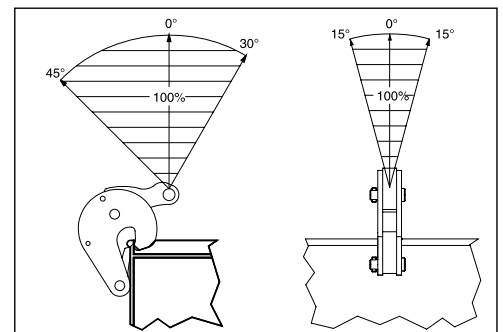

Crosby Lifting Clamps





**IPCC**

The IPCC is suitable for the vertical lifting and transfer of concrete pipe sections and wells. Very easy application and removal of the clamp thanks to the built-in carrying-grips. Normally used in combination with 7mm chain (not supplied). These clamps must be used in pairs or more.

**For Lifting and Transferring Concrete Pipe Sections and Wells**

- Available in capacity of 1 metric tons.
- Jaw opening available: 1.57" - 5.51".
- Welded alloy steel body for strength and smaller size. Forged alloy, components where required.
- Equipped with handle for easy placement.
- Individually Proof Tested to 2 times the Working Load Limit with certification.
- Company name (CrosbyIP), logo, Working Load Limit and jaw opening permanently stamped on body.
- Each product is individually serialized, with the serial number and Proof Load test date stamped on body. User manual with test certificate is included with each clamp
- Maintenance replacement parts are available.
- Manufactured by an ISO 9001 facility.
- All sizes are **RFID EQUIPPED**.

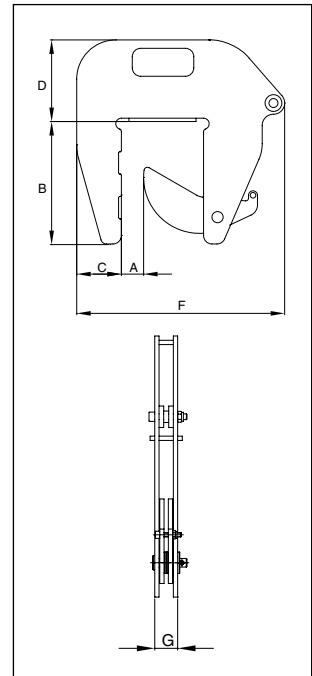

**Load Rated®**

**Model IPCC**

Model	IPCC Stock No.	Working Load Limit Per Pair (t.)*	Weight Each (lb)	Dimensions (in)									
				Jaw A	B	C	D	E	F	G	H	J	K
IPCC	2700037	1.0	40.6	1.56 - 5.50	8.86	3.15	5.75	-	14.65	1.46	-	-	-

\* Design Factor based on EN 13155 and ASME B30.20.

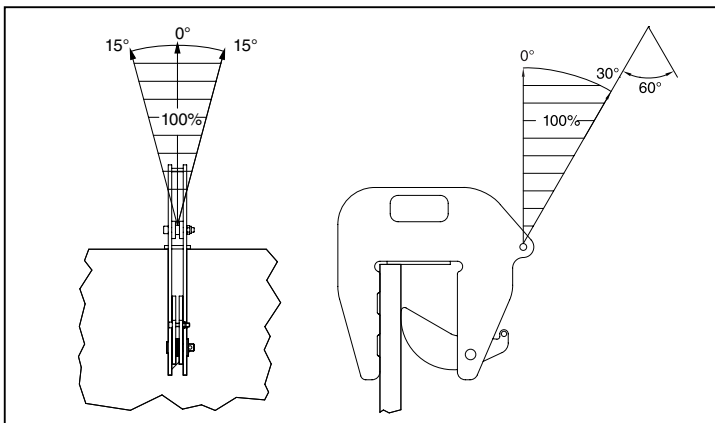

# Shipbuilding Clamps: Bulb Profiles



**IPBUZ**

The IPBUZ shipbuilding clamps are used for lifting, transferring and placing bulb profiles onto ship's hulls perpendicularly. These clamps are fitted with a locking device for both open and closed positions, which ensures complete reliability. They are to be used exclusively for bulb profiles (not for plates).

## For Lifting, Transferring and Placing Bulb Profiles onto Ship's Hulls Perpendicularly

- Available in capacities of .75 thru 3.75 metric tons.
- Jaw openings available: HP 4.75" to HP 16.93".
- Welded alloy steel body for strength and smaller size. Forged alloy components, where required.
- Individually Proof Tested to 2 times the Working Load Limit with certification.
- Company name (CrosbyIP), logo, Working Load Limit and jaw opening permanently stamped on body.
- Each product is individually serialized, with the serial number and Proof Load test date stamped on body. User manual with test certificate is included with each clamp.
- Optional IP-5000 Stinger assembly available (see page 428). Allows for easy connection between the clamp and hoist hook.
- Maintenance and repair kits are available.
- Manufactured by an ISO 9001 facility.

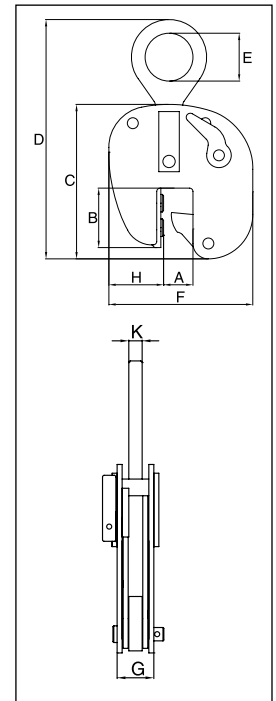

## Model IPBUUZ: with Universal Hoisting Eye Model IPBUZ: with Fixed Hoisting Eye

Model	Working Load Limit (t)*	IPBUZ Stock No.	Weight Each (lb)	Dimensions (in)								
				Profile A †	B	C	D	E	F	G	H	K
IPBUUZ	.75	2705601	18.7	HP 4.75 - 7.88	3.35	8.90	15.35	2.76	8.27	2.40	2.76	0.63
<b>With fixed hoisting eye</b>												
IPBUZ	.75	2705600	15.4	HP 4.75 - 7.88	3.35	8.90	15.35	2.76	8.27	2.40	2.76	0.63
IPBUZ	1.5	2705701	33.1	HP 8.63 - 17.00	7.72	15.63	22.36	2.76	10.08	2.72	1.89	0.63
IPBUZ	3.75	2705702	64.4	HP 8.63 - 17.00	9.37	17.24	22.24	3.15	13.98	2.52	3.94	0.79

\* Design Factor based on EN 13155 and ASME B30.20. † Profile A is the type of Holland Bulb (HP) style and size material.

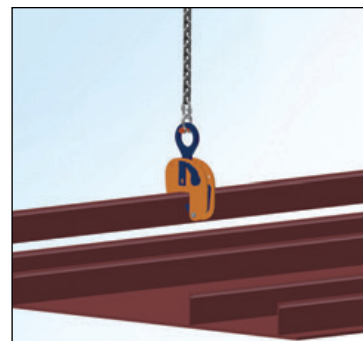
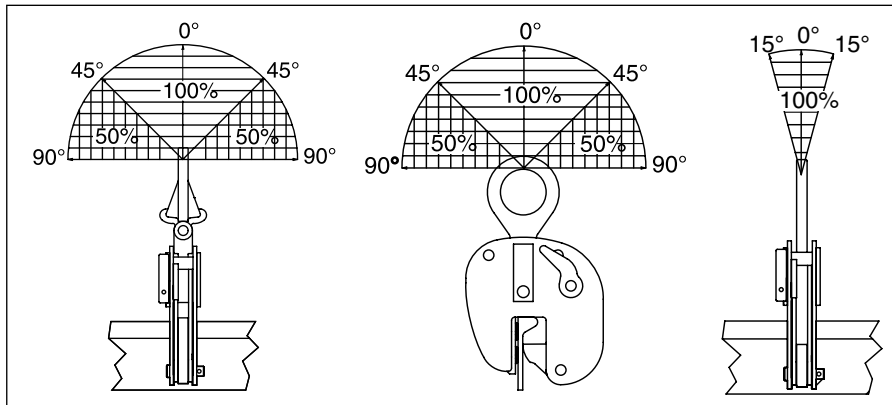

Crosby Lifting Clamps



**IPSBUUZ**

The IPSBU(U)Z shipbuilding clamps are used for the lifting, transfer and placing of complete shipsections. These clamps are fitted with a locking device for both open and closed positions, which ensures complete reliability. They are to be used exclusively for bulb profiles (not for plates).

**For Lifting, Transferring and Placing Complete Shipsections**

- Available in capacities of 4.5 thru 22.50 metric tons.
- Wide variety of jaw openings available: HP 3.94" to HP 16.93".
- Welded alloy steel body for strength and smaller size. Forged alloy components, where required.
- Individually Proof Tested to 2 times the Working Load Limit with certification.
- Company name (CrosbyIP), logo, Working Load Limit and jaw opening permanently stamped on body.
- Each product is individually serialized, with the serial number and Proof Load test date stamped on body. User manual with test certificate is included with each clamp.
- Optional IP-5000 Stinger assembly available (see page 428). Allows for easy connection between the clamp and hoist hook.
- Maintenance and repair kits are available.
- Manufactured by an ISO 9001 facility.
- All sizes are **RFID EQUIPPED**.

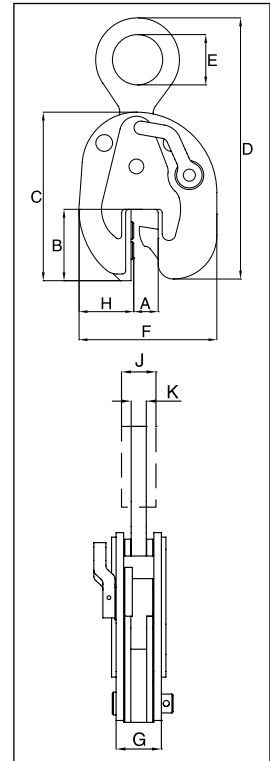

**Model IPSBUUZ and IPSBUSUZ: With Universal Hoisting Eye**  
**Model IPSBUZ and IPSBUSZ: With Fixed Hoisting Eye**

Model	Working Load Limit (t)*	IPSBUUZ Stock No.	Weight Each (lb)	Dimensions (in)									
				Profile A†	B	C	D	E	F	G	H	J	K
IPSBUUZ	4.5	2705771	34.2	HP 4.00 - 6.25	4.21	9.92	17.72	2.95	8.11	3.78	3.23	1.42	0.79
IPSBUUZ	9	2705773	94.8	HP 4.00 - 6.25	4.13	10.79	19.33	3.15	9.76	4.84	4.09	1.73	0.79
IPSBUSUZ	4.5	2705772	83.8	HP 7.13 - 17.00	8.94	16.85	25.00	2.95	14.84	3.74	5.04	-	0.79
IPSBUSUZ	9	2705774	152	HP 7.13 - 17.00	8.94	18.82	28.27	3.15	16.73	4.65	6.10	1.73	0.98
<b>With fixed hoisting eye</b>													
IPSBUZ	4.5	2705721	29.8	HP 4.00 - 6.25	4.21	9.92	15.04	2.95	8.11	3.78	3.23	-	0.79
IPSBUZ	9	2705723	50.7	HP 4.00 - 6.25	4.13	10.79	18.15	3.15	9.76	4.84	4.09	-	1.18
IPSBUSZ	4.5	2705722	78.9	HP 7.13 - 17.00	8.94	16.85	23.31	2.95	14.84	3.74	5.04	-	0.79
IPSBUSZ	9	2705724	150	HP 7.13 - 17.00	8.94	18.82	26.10	3.15	16.73	4.65	6.10	1.77	0.98
IPSBUSZ	15	2705728	141	HP 7.13 - 17.00	8.90	19.09	27.17	3.46	15.79	3.94	5.31	1.93	0.98
IPSBUSZ	22.5	2705730	220	HP 7.13 - 17.00	8.82	21.38	29.13	3.54	18.50	4.57	7.28	-	0.98

\* Design Factor based on EN 13155 and ASME B30.20. † Profile A is the type of Holland Bulb (HP) style and size material.

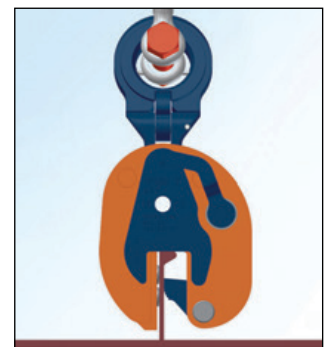
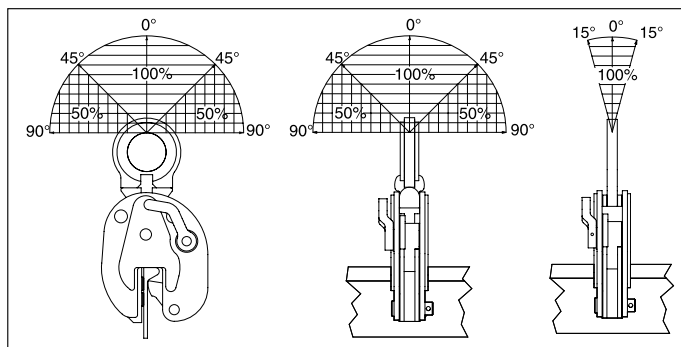

# Shipbuilding Clamps: Bulb Profiles



## IPBTO10

The IPBTO10 shipbuilding clamp is used as a temporary tackle eye in spaces which have been reinforced with HP (bulb) profiles such as engine rooms and shipsections. This clamp is fitted with a screwed spindle for easy attachment of the clamp. The moment a load is applied, the clamp is automatically fixed.

**For use as a temporary tackle eye in spaces that have been reinforced with HP (bulb) profiles such as engine rooms and shipsections.**

- Available in capacities of 1.5 thru 6 metric tons.
- Wide variety of jaw openings available: HP 6.3" to HP 16.93".
- Welded alloy steel body for strength and smaller size. Forged alloy components, where required.
- Individually Proof Tested to 2 times the Working Load Limit with certification.
- Company name (CrosbyIP), logo, Working Load Limit and jaw opening permanently stamped on body.
- Each product is individually serialized, with the serial number and Proof Load test date stamped on body. User manual with test certificate is included with each clamp.
- Maintenance and repair kits are available.

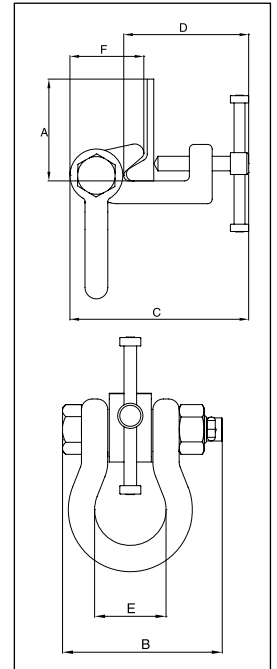

## Model IPBTO10

Model	Working Load Limit (t)*	IPBTO10 Stock No.	Weight Each (lb)	Dimensions (in)					
				Profile A †	B	C	D	E	F
IPBTO10	1.5	2700980	11.0	HP 6.5 - 9.44	5.39	7.40-8.23	5.08-5.91	2.68	3.19
IPBTO10	3	2700986	13.0	HP 9.44 - 12.56	5.39	7.40-8.54	5.71-6.85	2.68	3.07
IPBTO10	6	2700991	28.7	HP 11.75 - 17.00	7.28	10.03-11.69	7.68-9.29	3.23	4.02

\* Design Factor based on EN 13155 and ASME B30.20. † Profile A is the type of Holland Bulb (HP) style and size material.

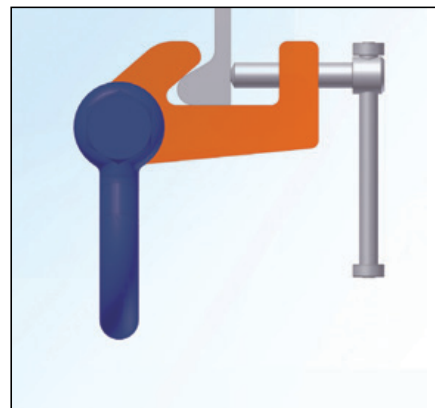
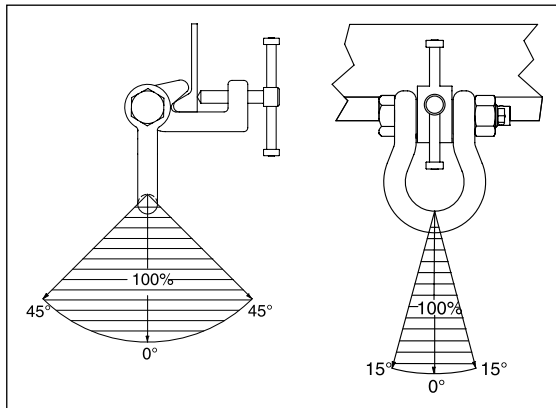





**IPSC10**

The IPSC10 screw style clamp is for positioning, pulling and turning plates or fabrications.

**Suitable for use in positioning & turning steel plates and sections.  
Not to be used as a lifting clamp.**

- Available in capacities of 1.5 and 3 metric tons.
- Jaw openings available: 0" to 2.36".
- Suitable for steel with a surface hardness up to 30 Rc.
- Forged alloy steel body for strength and smaller size. Forged alloy components, where required.
- Individually Proof Tested to 2 times the Working Load Limit with certification.
- Company name (CrosbyIP), logo, Working Load Limit and jaw opening permanently stamped on body.
- Each product is individually serialized, with the serial number and Proof Load test date stamped on body. User manual with test certificate is included with each clamp
- Manufactured by an ISO 9001 facility.



**Model IPSC10**

Model	Working Load Limit (t)*	IPSC Stock No.	Weight Each (lb)	Dimensions (in)									
				Jaw A	B	C	D	E	F	G	H	J	K
IPSC10	1.5	2703857	10.1	0 - 1.57	3.58	5.63	9.88	1.73	6.14	1.97	1.77	0.63	2.56
IPSC10	3	2703858	18.5	0 - 2.38	4.29	6.89	12.20	2.01	7.87	2.44	2.17	0.75	3.27

\* Design Factor based on EN 13155 and ASME B30.20.

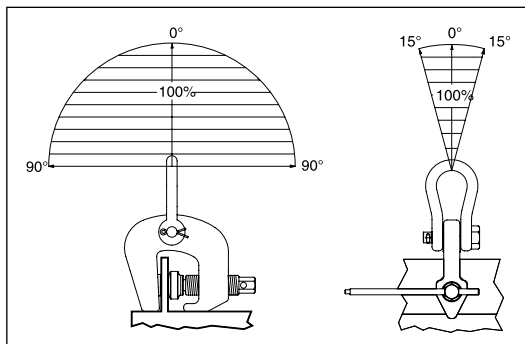
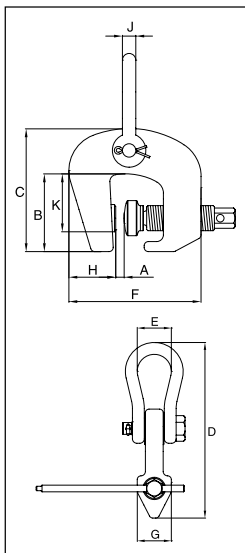

**IP5000**

The IP5000 Stinger Assembly is designed to be used as a connecting link between the clamp and the hoist hook.

**Provides easy attachment of selected Crosby® IP clamp to hoist hook.**

- Available in three sizes for the IP10 and IPU10 with capacities from .5 to 12 metric tons.
- Assembly consists of welded alloy master link, Grade 80 chain and A-1337 Lok-A-Loy for attachment to the clamp hoisting eye.
- Individually Proof Tested to 2.5 times the Working Load Limit of Grade 80 chain with certification
- Company name or logo and frame number permanently stamped on link.
- Locking system provides for simple assembly - no special tools needed.
- Finish - Red Paint.
- Manufactured by an ISO 9001 facility.

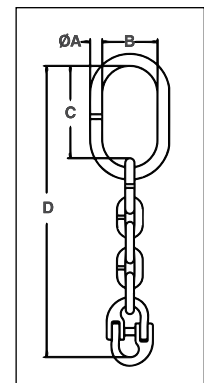

**NOTE: Not Intended to be Used as a Chain Sling.**

**Model IP5000**

Frame Size	Chain Size		Crosby® IP(U)10 Clamp Sizes (t)*	Crosby® IP(U)10H Clamp Sizes (t)*	IP5000 Stock No.**	Weight Each (lb)	Dimensions (in)			
	(in)	(mm)					A	B	C	D
1	5/16	8	0.5 - 1	0.5	2701695	2.10	.51	2.36	3.94	12.41
2	1/2	13	2 - 4.5	1 - 3	2701704	7.50	.87	3.54	5.67	19.06
3	7/8	22	6 - 12	4.5 - 6	2701713	32.4	1.42	5.51	9.22	32.27

\* The working load of the assembly is based on working load limit of the selected clamp. \*\*Ultimate load is 5 times the Working Load Limit.

**Crosby**<sup>®</sup> **CLAMP-CO**

# CLAMPS

**Setting the  
Standard  
for Lifting**

Pipe Clamps

Beam Clamps

Barrier Grabs

Granite/Curb Grabs





# Crosby®

## Crosby CLAMP-CO®

The new Crosby Clamp-Co® Adjustable Pipe Grab provides an excellent means of handling cylindrical objects. Featuring *padded grabs*, the new Grab offers an excellent method of handling any pipe or solid bar, 3.5" to 36" (88.9 mm to 914 mm), especially where damage to material surface is not permitted.

- Capacities: 1,200 lb to 20,000 lb (544 kg to 9,072 kg)
- Each Grab size accommodates several diameters of pipe or solid bar.
- Auto indexing system provides quick connect and disconnect to load (one person - hands free).
- Individually Proof Tested to 2 times the Working Load Limit with certification
- Designed to handle loads of various types of material, including:
  - Cast Iron / Steel
  - PVC
  - Painted
  - Epoxy Coated
- Finish - Red Paint
- Replacement pads are available.
- Features Crosby shackle as upper connection point.
- Custom sizes are available.
- All sizes are **RFID EQUIPPED.**



## Clamp-Co Adjustable Padded Pipe Grab



### Features Include:



Easy lock and unlock transport lever.

Auto indexing mechanism (one person - hands free)



Replaceable Pads



## Crosby®

[thecrosbygroup.com](http://thecrosbygroup.com)

# CROSBY Clamp-Co® Padded Pipe Grab



CCPA



The new Crosby Clamp-Co® Adjustable Pipe Grab provides an excellent means of handling cylindrical objects. Featuring padded grabs, the new Grab offers an excellent method of handling any pipe or solid bar, 3.5” to 36”, especially where damage to material surface is not permitted.

- Capacities: 1,200 lb to 20,000 lb
- Each Grab size accommodates several diameters of pipe or solid bar.
- Auto indexing system provides quick connect and disconnect to load (one person - hands free).
- Individually Proof Tested to 2 times the Working Load Limit with certification
- Designed to handle loads of various types of material, including:
  - Cast Iron / Steel
  - PVC
  - Painted
  - Epoxy Coated
- Finish - Red Paint
- Replacement pads are available.
- Features Crosby shackle as upper connection point.
- Custom sizes are available.
- All sizes are **RFID EQUIPPED**.
- Only Models PA-5 and PA-8 come with a shackle.



## Padded Pipe Grab

Model No.	CCPA Stock No.	Working Load Limit* (lb)	Weight Each (lb)	Grip Width	Dimensions (in)					
					A	B	C	D	E	F
PA-5	2736000	1200	23	Locked Open	13.50	10.00	18.00	6.50	1.31	.50
				Min. Pipe 3.50"	27.00	9.00	8.00			
				Max. Pipe 5.56"	23.00	9.00	14.75			
PA-8	2736009	2000	75	Locked Open	23.50	15.50	27.75	10.00	1.69	.63
				Min. Pipe 5.56"	40.50	14.50	14.00			
				Max. Pipe 8.81"	34.00	14.75	24.00			
PA-14	2736018	4500	230	Locked Open	28.75	24.00	28.50	15.50	1.50	1.00
				Min. Pipe 8.81"	46.00	22.50	13.50			
				Max. Pipe 14.00"	34.00	23.00	26.00			
PA-22	2736027	10,000	496	Locked Open	42	36	42.5	20	2.5	1.5
				Min. Pipe 14.00"	67.5	34	19			
				Max. Pipe 22.00"	52	36	40			
PA-36	2736036	20,000	1250	Locked Open	57.27	57.03	57.31	30.00	3.37	1.50
				Min. Pipe 24.00"	92.02	52.38	26.98			
				Max. Pipe 36.00"	66.36	55.03	53.24			

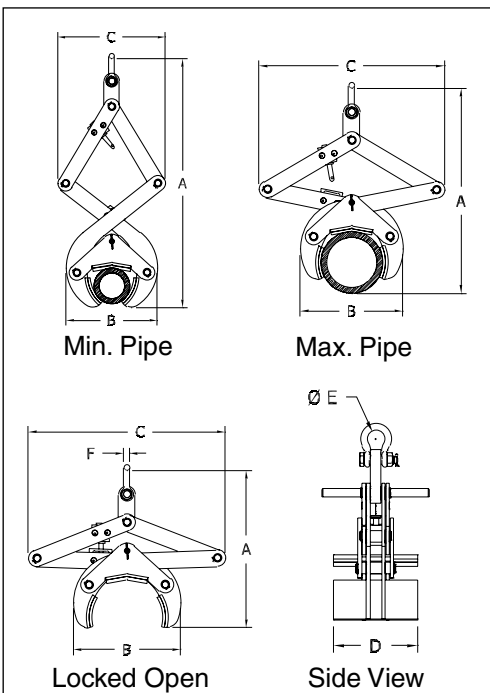

\* Maximum Proof Load is 2 times the Working Load Limit and design factor based on EN13155 and ASME B30.20.



## CROSBY Clamp-Co® Pipe Grabs

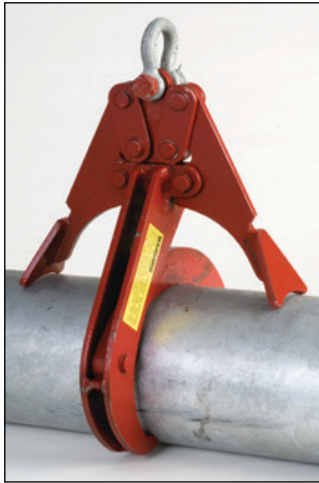

**CCPG**

**Crosby Clamp-Co® Pipe Grabs provide an excellent means of handling cylindrical objects as long as they meet Pipe O.D. and Working Load Limits referenced in the table below.**

- Capacities: 450 lb to 7,000 lb
- Moveable outriggers help stabilize the load.
- No blocking of load required.
- Individually Proof Tested to 2 times the Working Load Limit with certification
- Designed to handle loads of various types of material, including:
  - Cast Iron
  - Steel
  - PVC
  - C900
  - Yellowmine Ductile Iron
  - Cement Pipe
- Finish - Red Paint.
- Custom sizes are available.
- All sizes are **RFID EQUIPPED**.

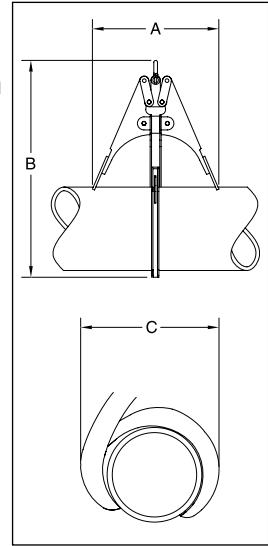

**NOTE:** Pipe grab sizes listed will handle all classes in a category of ASA standard cast iron pipe, C900, Yellowmine, Schedule 40, 80 & 120 PVC or ASA standard steel welded and seamless pipe. Standard, extra strong and double extra all have the same outside diameter.

### For Cast Iron Pipe C-900, C-905, Bluestripe C-906, Certa-Lok PVC Pressure Pipe

Model No.	CCPG- 900 Stock No.	Working Load Limit (lb)*	Pipe O.D. (in)	Weight Each (lb)	Dimensions (in)		
					A	B	C
C-3	2730000	450	4.00	10.0	5.00	10.00	6.00
C-4	2730009	600	4.80	11.0	8.00	14.00	7.00
C-6	2730018	1000	6.90	15.0	11.00	17.00	11.00
C-8	2730027	1400	9.05	25.0	13.00	22.00	14.00
C-10	2730036	2000	11.1	48.0	15.00	27.00	17.00
C-12	2730045	2500	13.2	72.0	18.00	32.00	20.00
C-14	2730054	3500	15.3	105	22.00	38.00	23.00
C-16	2730063	4000	17.4	130	24.00	42.00	25.00
C-18	2730072	5000	19.5	170	26.00	45.00	28.00
C-20	2730081	6500	21.6	210	28.00	50.00	32.00
C-24	2730090	7000	25.8	225	31.00	58.00	35.00

\* Maximum Proof Load is 2 times the Working Load Limit and design factor based on EN13155 and ASME B30.20.

### For Steel Pipe SDR Class 200, Yellowmine, PVC Schedule 40, 80 and 120

Model No.	CCPG- 200 Stock No.	Working Load Limit (lb)*	Pipe O.D. (in)	Weight Each (lb)	Dimensions (in)		
					A	B	C
S-3	2731000	450	3.50	10.0	5.00	10.00	6.00
S-4	2731009	600	4.50	11.0	8.00	14.00	7.00
S-6	2731018	1000	6.63	15.0	11.00	17.00	11.00
S-8	2731027	1400	8.63	25.0	13.00	22.00	14.00
S-10	2731036	2000	10.75	48.0	15.00	27.00	17.00
S-12	2731045	2500	12.75	72.0	18.00	32.00	20.00
S-14	2731054	3500	14.0	105	22.00	38.00	23.00
S-16	2731063	4000	16.0	130	24.00	42.00	25.00
S-18	2731072	5000	18.0	170	26.00	45.00	28.00
S-20	2731081	6500	20.0	210	28.00	50.00	32.00
S-24	2731090	7000	24.0	225	31.00	58.00	35.00

\* Maximum Proof Load is 2 times the Working Load Limit and design factor based on EN13155 and ASME B30.20.

# CROSBY Clamps-Co<sup>®</sup> Beam Clamps



CCBC

**Crosby Clamp-Co<sup>®</sup> Beam Clamps provide an efficient method for handling wide flange beam sections and plate girders. When lifting, these beam clamps grip the beam at three points, and when properly balanced and safely guided, the beam can be handled even if the clamp is slightly off center lengthwise.**

- Capacities: 5 Tons to 35 Tons
- Eliminates the need for slings, chokers, and spreader bars.
- When applied to load, the tongs automatically open and slide under the flange of the beam
- Center plate and gripping tongs work together - the heavier the beam, the greater the clamping pressure.
- Model "NS" clamps have a recessed base to accept studs welded to the beam surface.
- Individually Proof Tested to 2 times the Working Load Limit with certification
- Finish - Red Paint.
- All sizes are **RFID EQUIPPED**.



**NOTE:** Control the beam at all times. Beams should be gripped as near the center as possible. Snubbing lines at each end must be used to control excessive twisting or swinging, and to guide the beam to its proper place. Each lifting situation may have a specific demand which should be addressed before lifting.

## Beam Clamps

Model No.	CCBC Stock No.	Working Load Limit (Tons)*	Flange Grip Range (in)		Weight Each (lb)	Dimensions (in)									
			Width	Thickness		A	B	C	D	E	F	G	H	J	
F-5	2732000	5	4 - 10	.5 - 1	70.0	9.50	26.00	12.00	20.00	25.50	16.00	4.00	10.00	1.00	
NS-15	2732018	15	7 - 17	.5 - 2	153	15.50	34.00	17.00	27.00	34.50	25.00	7.00	17.00	2.00	
NS-25	2732036	25	16 - 24	1 - 3	290	23.00	48.00	22.25	36.00	53.00	37.25	16.00	24.00	3.00	
NS-35	2732054	35	16 - 36	1.63 - 4	519	30.00	64.00	27.50	48.00	58.00	53.00	16.00	36.00	4.00	

\* Maximum Proof Load is 2 times the Working Load Limit and design factor based on EN13155 and ASME B30.20. NOTE: : For beam clamps larger than 35 Tons, please contact the Crosby Special Engineered Products Department.

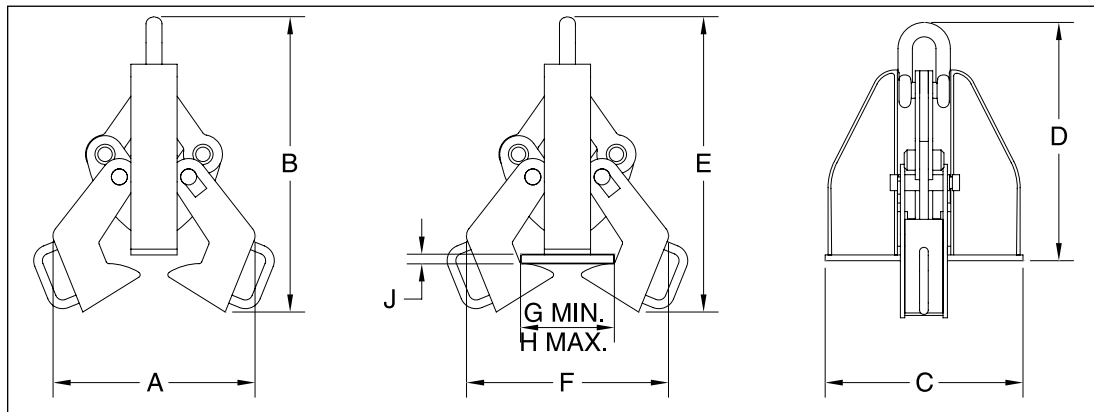

Base Stock No.	Base Dimensions (in)						
	C	L	M	N	P	S	T
F-5	13.50	-	-	-	-	3.00	-
NS-15	17.00	.50	6.50	4.50	.75	4.00	2.50
NS-25	22.25	.75	7.75	6.50	.75	5.50	4.00
NS-35	27.50	.75	9.00	8.50	.75	6.00	4.50

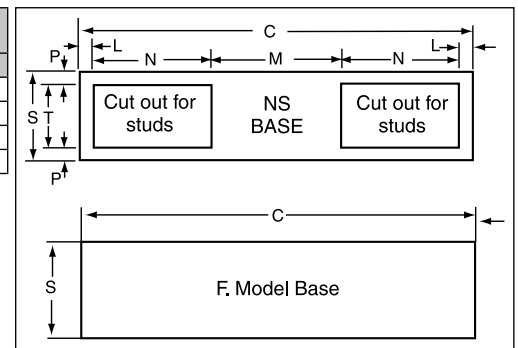

Crosby Lifting Clamps

## CROSBY Clamp-Co® Barrier / Curb Grabs



**CCBG**

**Crosby Clamp-Co® Barrier Grabs provide a fast and efficient method for handling concrete road barriers.**

- Hands-free operation.
- Alloy Steel Construction.
- Comes equipped with polyurethane pads. (Replacement kits available).
- Eliminates the need for slings, chokers and spreader bars.
- Individually Proof Tested to 2 times the Working Load Limit with certification .
- Finish - Red Paint.
- All sizes are **RFID EQUIPPED**.

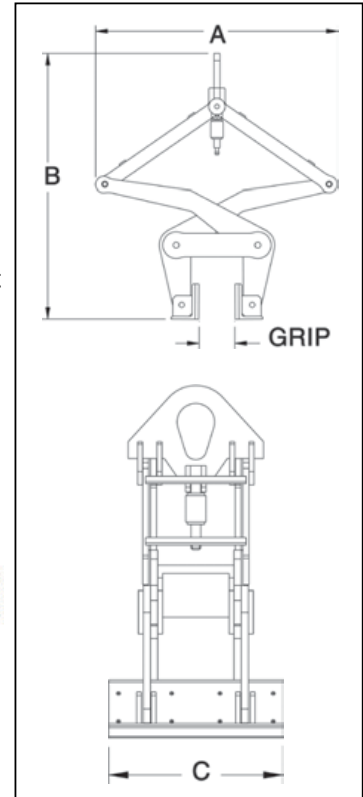

### Barrier Grab

Model No.	CCBG-150 Stock No.	Working Load Limit (Tons)*	Weight Each (lb)	Grip Width (in)	Dimensions (in)		
					A	B	C
BG-9000	2734009	4.5	290	6 (min.)	40.88	44.88	18.00
				12 (max.)	44.00	36.75	18.00

\* Design factor based on EN13155 and ASME B30.20.



**CCCG**

**Crosby Clamp-Co® Curb Grabs provide a fast and efficient method for handling large granite curbs.**

- Virtually no manual assistance is required.
- Alloy Steel Construction.
- Available with polyurethane pads or hardened steel jaw. (Replacement kits available).
- Eliminates the need for slings, chokers and spreader bars.
- Individually Proof Tested to 2 times the Working Load Limit with certification .
- Finish - Red Paint.
- All sizes are **RFID EQUIPPED**.

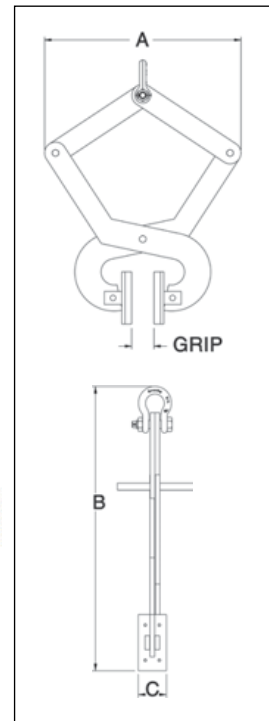

### Curb Grab

Model No.	CCGG-140 StockNo.	Working Load Limit (lb)*	WeightEach (lb)	Grip Width (in)	Dimensions (in)		
					A	B	C
CG-1400	2734000	1400	37.0	4 (min.)	22.5	27.25	3.00
				7 (max.)	25.0	20.25	3.00

\* Design factor based on EN13155 and ASME B30.20.

# CROSBY Clamp -Co® Pipe Hooks



CCPH

**Crosby Clamp-Co® Pipe Hooks provide a fast and efficient method for lifting pipe, tube or any similarly shaped fabrications.**

- Alloy steel plate construction.
- Equipped with a convenient handle.
- Equipped with a Bolt Type Shackle.
- Non marring inserts available.
- Used in pairs with 45° - 60° horizontal angle or 60° - 90° included angle.

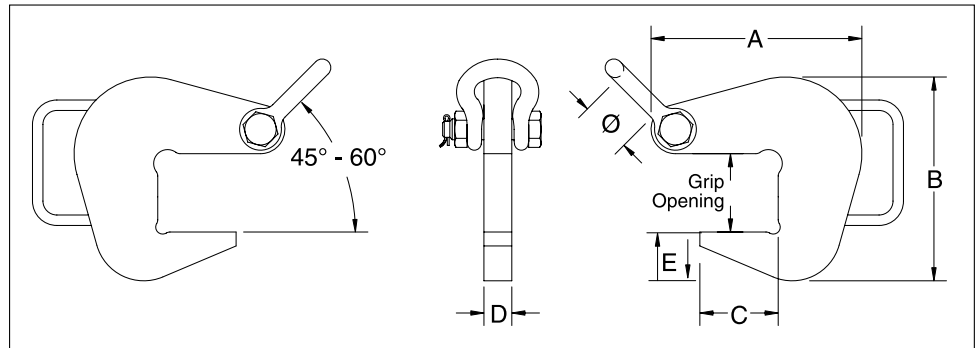

## Pipe Hook

Model	CCPH Stock No.	Working Load Limit Per Pair (t)**	Grip Opening (in)	Weight Each (lb)	Dimensions (in)						Shackle Size (in)	Cast Aluminium Inserts*
					A	B	C	D	E	Ø		
PH-2	2734500	2	2.06	5.94	5.81	5.06	2.06	1.00	1.25	1.69	5/8	2734800 2734809
PH-4	2734509	4	2.81	10.03	7.56	7.31	2.81	1.00	1.75	1.69	5/8	2734818
PH-6	2734518	6	4.06	17.74	10.18	10.06	4.06	1.00	2.25	2.00	3/4	2734827
PH-10	2734527	10	6.06	38.67	14.81	15.06	6.06	1.00	3.50	2.69	1.0	2734836

\* See CCPHI chart for Pipe ID range. \*\*Design factor based on EN13155 and ASME B30.20. Contact our Specials Sales Department for custom Pipe Hooks or reference the special request form on page 465.

**NOTE:** To determine grip opening when equipped with an insert, add the insert thickness shown in the Pipe Hook Insert table below.

## Pipe Hook Inserts

- Replaceable cast aluminium inserts for use with the CCPH Pipe Hook that minimizes thread and pipe damage.

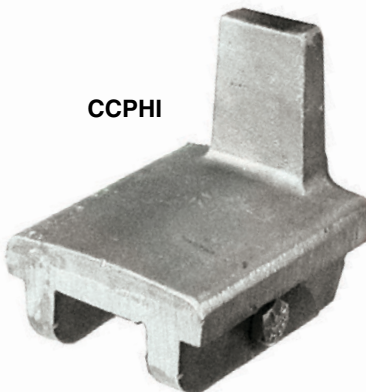

CCPHI

### CCPHI

Model	CCPHI Stock No.	ID of Pipe (in)	Insert Thickness (in)
CCPHI	2734800	3-12	PH-2 = 0.7
	2734809	12-18	PH-2 = 1.3
	2734818	18-30	PH-4 = 1.3
	2734827	30-42	PH-6 = 1.8
	2734836	42-72	PH-10 = 2.3



Crosby Lifting Clamps





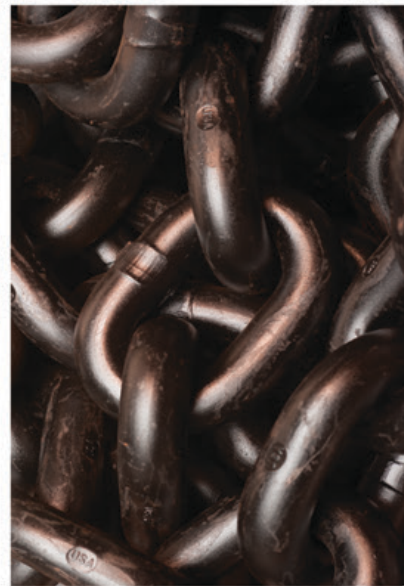

# CROSBY TRAWLEX® PRODUCTS



# Crosby Trawlex®

## DESIGNED FOR THE RIGOURS OF COMMERCIAL FISHING

Crosby Trawlex® offers a range of chain and components specifically devised for the rigours of commercial fishing. From the outset, it has been created with the end user in mind. By designing the range of products with experienced trawler men and with the use of extensive seagoing research, Crosby Trawlex® has proven to be the most versatile and cost effective method of trawl rigging available.

The complete Crosby Trawlex® range of products is enriched with super-strength capabilities as a result of special steels and heat treatment used in the manufacturing process. The heat treatment also ensures that ductility is retained, resulting in the products being highly resistant to the effects of shock loading and wear.

## PROFILE CHAIN - THE SHAPE OF THINGS TO COME!

The real challenges to fishing gear when new, are set by the industry's severe environment. These conditions may result in early failures caused by wear and corrosion. The new Crosby Trawlex® Profile Chain has been designed to take up these challenges.

**Wear** – The revolutionary design and the use of wear resistant materials in Crosby Trawlex® Profile Chain have greatly reduced the effects of wear, the main cause of reduction in a chain's tensile strength, compared with traditional chain (fig1).



**Corrosion and Fatigue** – As yet, corrosion cannot be eliminated at an acceptable cost; however the increased contact areas of Crosby Trawlex® Profile Chain (fig2), together with the use of improved materials and heat treatment, have radically reduced the chances of stress and fatigue and therefore the effects of corrosion.



# BENEFIT FROM OUR EXPERTISE

Compare Crosby Trawlex® chain and components to other products on the market and you will soon see the benefits of using Crosby Trawlex®.

Operating costs of the trawler are reduced as a result of the high strength, wear resistance and shock resistance of the products. The ingenious design of Crosby Trawlex® parts allows a wide range of components to be used in different rig positions in all methods of trawling.

Time is saved by incorporating a unique clevis and load pin assembly method. Less time is spent assembling a rig, and only the simplest tools are required for the process.

Time is also saved as a result of the superior lightness of Crosby Trawlex® chains and parts. Handling is much easier and the products are less bulky to transport.

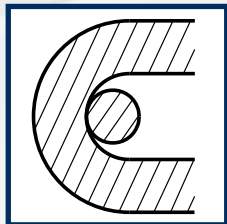

Round Chain

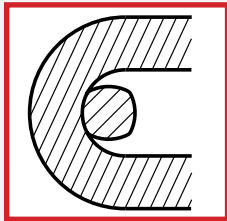

Profile Chain

Fig 2. Link contact area cross section.

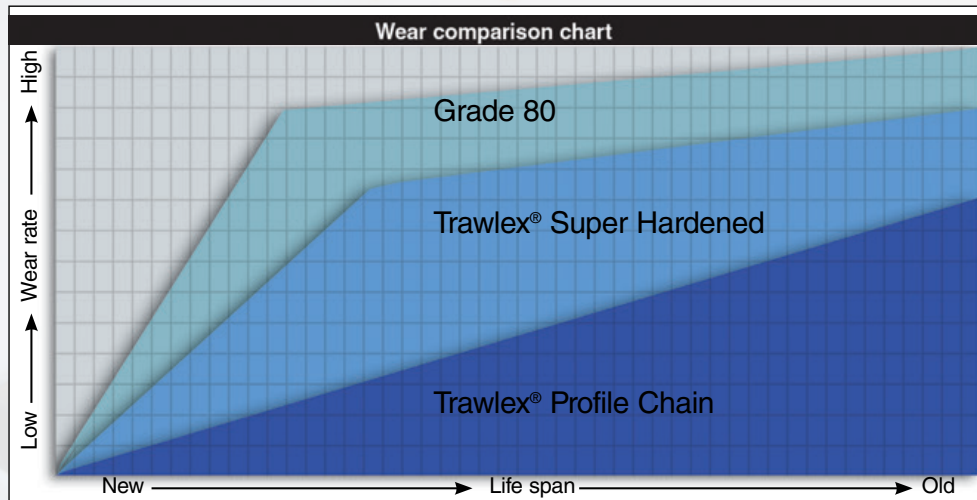
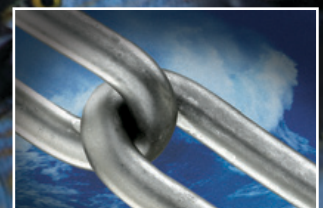

Fig 1.

## Trawlex® Benefits

- **Innovators** – World's first chain maker to attain BS EN ISO 9001.
- **Diversity** – Widest range of chain sizes, calibrated stability.
- **Testing** – 100% non-destructive testing on all products.
- **Properties** – Fatigue life up to 4 times specification plus improved resistance to stress corrosion.
- **Performance** – Materials optimised for low temperature conditions.
- **Weight** – Lighter and less bulky products.
- **Research** – Trawlex® has a comprehensive research policy to constantly seek improvements to our products.





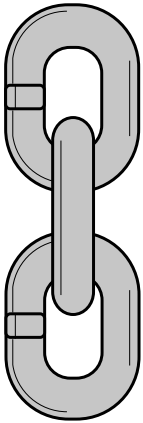

All breaking loads are in metric tonnes. To maximize the benefits of the improved strength of the chain, only use compatible Trawlex® fittings.

**Crosby Trawlex® Short Link Chain**

Model	Stock No.	Chain Dia. (mm)	Link Dimensions (mm)		Breaking Load (t)		Weight (kg)	Standard Length (m)
			Pitch	Width	Trawlex®	Grade 80		
TRAW-SL	2781650	10	30	14	15.5	12	2.2	200
TRAW-SL	2781652	13	39	18.1	26.5	20	3.61	150
TRAW-SL	2781635	16	48	22.4	41	30	5.41	110
TRAW-SL	2781644	19	57	26.6	57	45	7.81	75

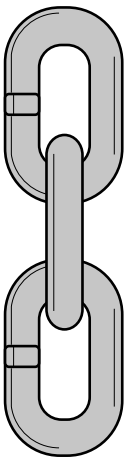

**Crosby Trawlex® Mid Link Chain**

Model	Stock No.	Chain Dia. (mm)	Link Dimensions (mm)		Breaking Load (t)		Weight (kg)	Standard Length (m)
			Pitch	Width	Trawlex®	Grade 80		
TRAW-ML	2784579	10	40	15	15.5	12	1.85	250
TRAW-ML	2784561	13	52	19.5	26.5	20	3.21	150
TRAW-ML	2784507	16	64	22.4	41	30	4.86	110
TRAW-ML	2784516	16	64	22.4	41	30	4.86	600
TRAW-ML	2781653	16	64	22.4	41	30	4.86	110
TRAW-ML	2784534	16	64	22.4	41	30	4.86	600
TRAW-ML	2784570	19	76	27	57	45	6.92	75
TRAW-ML	2784525	19	76	27	57	45	6.92	300
TRAW-ML	2781662	19	76	27	57	45	6.92	75
TRAW-ML	2784543	19	76	27	57	45	6.92	300
TRAW-ML	2781671	22	86	26	70	60	9.24	60
TRAW-ML	2784552	22	86	26	70	60	9.24	110
TRAW-ML	2781680	26	92	30	95	85	13.66	50

 Denotes Profile Chain

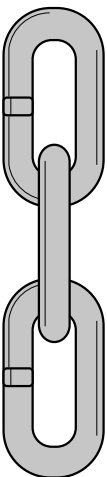

**Crosby Trawlex® Long Link Chain**

Model	Stock No.	Chain Dia. (mm)	Link Dimensions (mm)		Breaking Load (t)		Weight (kg)	Standard Length (m)
			Pitch	Width	Trawlex®	Grade 80		
TRAW-LL	2781699	9	53	15	12.5	10	1.36	200
TRAW-LL	2781706	11	63	18	18.5	15	2.03	150
TRAW-LL	2781715	13	80	22	26.5	20	2.83	150
TRAW-LL	2781720	13	80	22	26.5	20	2.83	600
TRAW-LL	2784339	16	100	24.5	40	30	4.34	100
TRAW-LL	2784348	16	100	24.5	40	30	4.34	600
TRAW-LL	2781724	16	100	24.5	40	30	4.34	100
TRAW-LL	2784320	16	100	24.5	40	30	4.34	600
TRAW-LL	2784357	19	100	25	57	45	6.31	108
TRAW-LL	2781733	19	100	25	57	45	6.31	108
TRAW-LL	2781742	22	120	35.5	70	60	8.74	70
TRAW-LL	2781751	28	150	46	105	95	14.41	50

 Denotes Profile Chain

# Crosby Trawlex® Components

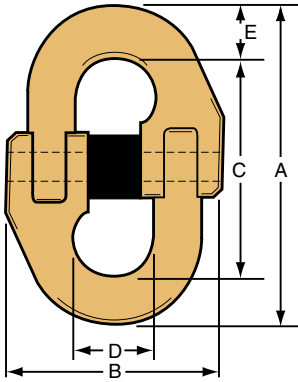

## Crosby Trawlex® Component Connector TLN

Model	Stock No.	Chain Dia. (mm)	Dimensions (mm)					Weight (kg)
			A	B	C	D	E	
TL7N	2780583	7	67	49	48	14.3	9	.11
TL10N	2780592	10	89	66	64	19.2	13	.36
TL13N	2780609	13	118	85	85	26.5	17	.66
TL16N	2780618	16	144	96	106	32	19	1.08
TL19N	2780627	19	168	115	122	38.5	23	1.77
TL23N	2780636	23	206	140	150	49	28	2.8
TL26N	2780645	26	230	163	166	57	32	4.4
TL32N	2780654	32	278	210	200	63	39	8.4

Individually Proof Tested to 2.5 x WLL.

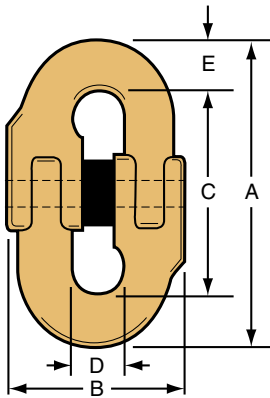

## Crosby Trawlex® Chain Connector KJ

Model	Stock No.	Chain Dia. (mm)	Dimensions (mm)					Weight (kg)
			A	B	C	D	E	
KJ7	2780663	7	56	34	41	8	7.5	.09
KJ10	2780672	10	73	45	51	11.5	11	.27
KJ13	2780681	13	94	61	65	14.7	14	.44
KJ16	2780690	16	120	75	84	19.1	18	.83
KJ19	2780707	19	142	90	100	22.9	21	1.42

Individually Proof Tested to 2.5 x WLL.

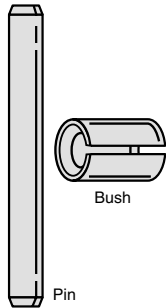

## Crosby Trawlex® Chain & Component Connector Spares

Component Connector TL				Chain Connector KJ			
Pin		Bush		Pin		Bush	
Model	Stock No.	Model	Stock No.	Model	Stock No.	Model	Stock No.
TL7PIN	2784222	TL7BUSH	2784142	KJ7PIN	2783116	KJ7BUSH	2783063
TL10PIN	2784231	TL10BUSH	2784151	KJ10PIN	2783125	KJ10BUSH	2783072
TL13PIN	2784240	TL13BUSH	2784160	KJ13PIN	2783134	KJ13BUSH	2783081
TL16PIN	2784259	TL16BUSH	2784179	KJ16PIN	2783143	KJ16BUSH	2783090
TL19PIN	2784268	TL19BUSH	2784188	KJ19PIN	2783152	KJ19BUSH	2783107
TL23PIN	2784277	TL13BUSH	2784197	-	-	-	-
TL26PIN	2784286	TL26BUSH	2784204	-	-	-	-
TL32PIN	2784295	TL32BUSH	2784213	-	-	-	-

Full details of the load and retaining pins required for each Trawlex® component are shown on Trawlex® Data Sheet TX191, available on request.

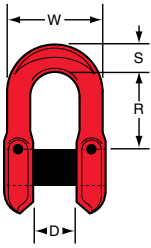

Crosby Trawlex® 'D' Shackle TXRC

Model	Stock No.	Chain Dia. (mm)	Dimensions (mm)				Weight (kg)
			R	W	D	S	
TXRC16	2781760	16	57	72	35	22	.9

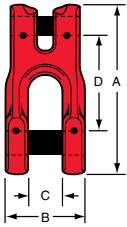

Crosby Trawlex® Clevis Shackle TXCS

Model	Stock No.	Chain Dia. (mm)	Dimensions (mm)				Weight (kg)
			A	B	C	D	
TXCS16	2781788	16	200	90	45	113	2.5

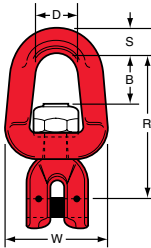

Crosby Trawlex® Swivel TXSW

Model	Stock No.	Chain Dia. (mm)	Dimensions (mm)					Weight (kg)
			R	W	D	B	S	
TXSW13	2781797	13	127	94	41	51	22	1.93
TXSW16	2781804	16	162	111	51	60	29	3.29



Crosby Trawlex® Double Nibbed Link TXDR

Model	Stock No.	Chain Dia. (mm)	Dimensions (mm)		Weight (kg)
			A (pitch)	B (width)	
TXDR13	2781813	13	108	54	.89
TXDR16	2781822	16	127	63	1.6

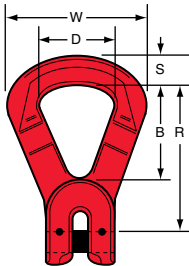

Crosby Trawlex® Recessed Link TXRL

Model	Stock No.	Chain Dia. (mm)	Dimensions (mm)					Weight (kg)
			R	W	D	B	S	
TXRL13	2781831	13	125	117	63	84	22	1.6
TXRL16	2781840	16	156	156	89	108	27	2.72

Note: .75 to .87 inch sizes available upon request.

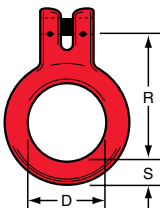

Crosby Trawlex® Kelly's Eye TXKE

Model	Stock No.	Chain Dia. (mm)	Dimensions (mm)			Weight (kg)
			R	D	S	
TXKE16	2781859	16	187	95	28	4.42

Note: .75 to .87 inch sizes available upon request.

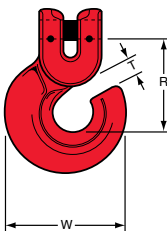

Crosby Trawlex® 'G' Hook TXG

Model	Stock No.	Chain Dia. (mm)	Dimensions (mm)			Weight (kg)
			R	T	W	
TXG13	2781868	13	82	16	106	1.51
TXG16	2781877	16	100	20	114	2.38

Note: .75 to .87 inch sizes available upon request.





# Setting a World-Class Standard in Subsea Lifting

Crosby® is a trusted partner in the subsea industry, priding ourselves on being the leading innovator with quality service to back it up. We understand that the unique needs and demanding applications involved in subsea work require products and training that are time-tested and proven.



**Offshore Platform Applications**



**Underwater / Subsea ROV Applications**











# RIGGING INFORMATION



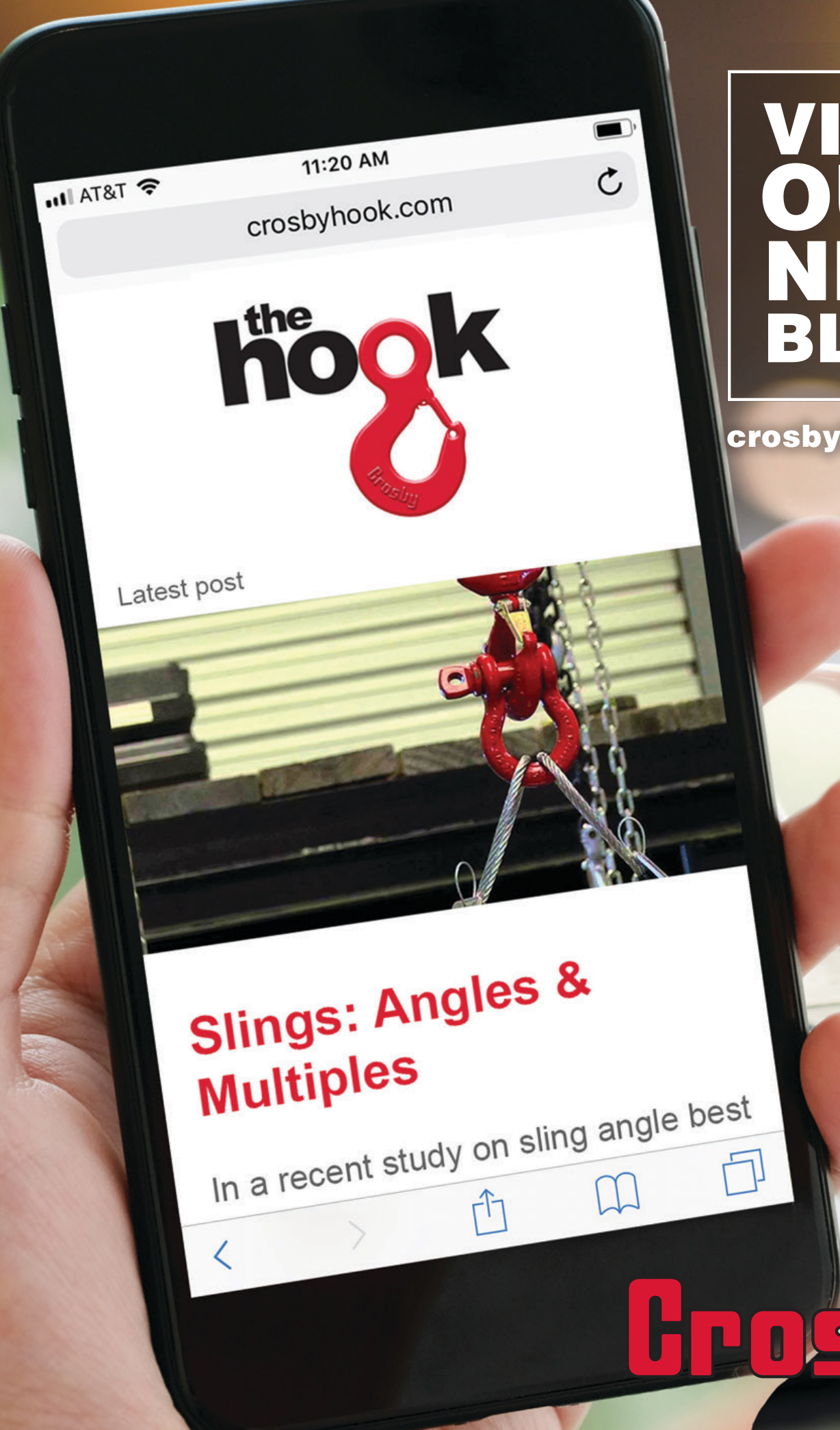

11:20 AM

AT&T

crosbyhook.com



Latest post

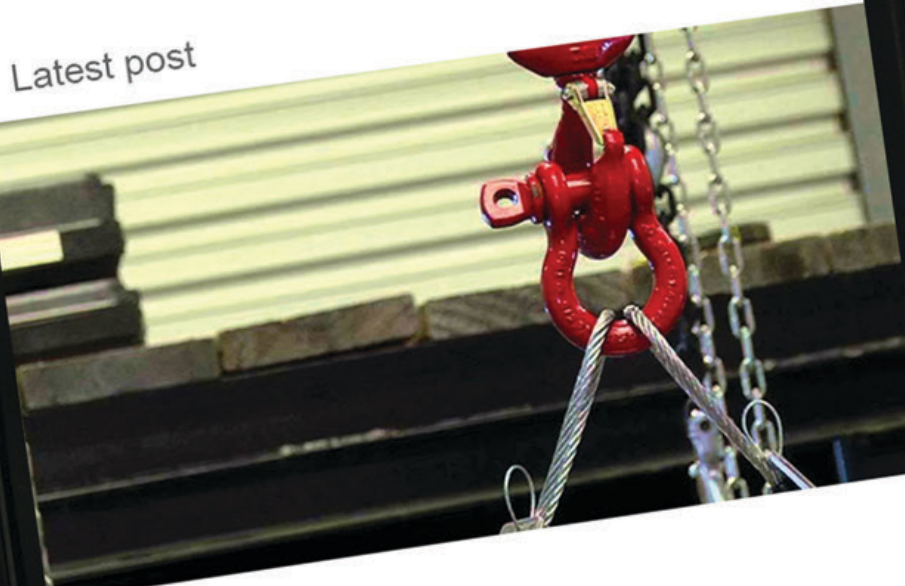

## Slings: Angles & Multiples

In a recent study on sling angle best

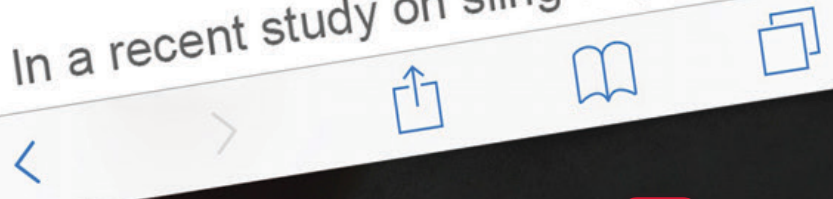

**VISIT  
OUR  
NEW  
BLOG**

[crosbyhook.com](http://crosbyhook.com)

**Crosby®**

## Crosby® USERS GUIDE FOR LIFTING

ASME VERSION (3/18)

RISK MANAGEMENT	TERMINOLOGY	FOR ADDITIONAL SUPPORT
<b>DEFINITION</b>	<b>WORKING LOAD LIMIT (WLL)</b>	<p>P.O. Box 3128 Tulsa Oklahoma 74101 Phone: (918) 834-4611 1-800-777-1555</p> <p>Web: www.thecrosbygroup.com E-Mail: crosbygroup@thecrosbygroup.com</p> <p><b>BLOCKS &amp; FITTINGS FOR WIRE ROPE &amp; CHAIN</b></p> <p><b>CROSBY® FITTINGS LEBUS® McKISSICK® CROSBY IP® NATIONAL®</b></p>
COMPREHENSIVE SET OF ACTIONS THAT REDUCES THE RISK OF A PROBLEM, A FAILURE, AN ACCIDENT	THE MAXIMUM MASS OR FORCE WHICH THE PRODUCT IS AUTHORIZED TO SUPPORT IN A PARTICULAR SERVICE.	
ASME B30.9 (SLINGS) AND ASME B30.26 (RIGGING HARDWARE) REQUIRES USERS TO HAVE TRAINING.	<b>PROOF TEST</b>	
USERS SHALL BE TRAINED IN THE SELECTION, INSPECTION, CAUTIONS TO PERSONNEL, EFFECTS OF ENVIRONMENT AND RIGGING PRACTICES.	A TEST APPLIED TO A PRODUCT SOLELY TO DETERMINE INJURIOUS MATERIAL OR MANUFACTURING DEFECTS.	
ALL SLINGS AND RIGGING HARDWARE REQUIRE PROPER IDENTIFICATION.	<b>ULTIMATE STRENGTH</b>	
RIGGING HARDWARE AT MINIMUM TO BE IDENTIFIED WITH NAME OR TRADEMARK OF THE MANUFACTURER.	THE AVERAGE LOAD OR FORCE AT WHICH THE PRODUCT FAILS OR NO LONGER SUPPORTS THE LOAD.	
SEE ASME B30.9, ASME B30.10 AND ASME B30.26 FOR FULL INFORMATION	<b>DESIGN FACTOR</b>	
REFER TO CROSBY GROUP CATALOG AND OTHER PRODUCT APPLICATION INFORMATION.	AN INDUSTRIAL TERM DENOTING A PRODUCT'S THEORETICAL RESERVE CAPABILITY; USUALLY COMPUTED BY DIVIDING THE CATALOG ULTIMATE LOAD BY THE WORKING LOAD LIMIT. GENERALLY EXPRESSED AS A RATIO, e.g. 5 TO 1.	

**Load Rated®**

### THE BASIC RIGGING PLAN

PLAN EVERY LIFT. THE QUESTIONS TO ANSWER BELOW ARE JUST A GOOD STARTING POINT BEFORE THE MATERIAL MOVING ACTIVITY BEGINS. ADD QUESTIONS FROM YOUR PAST EXPERIENCE OR JOB SPECIFIC REQUIREMENTS.

1. WHO IS RESPONSIBLE FOR THE RIGGING?
2. HAS COMMUNICATION BEEN ESTABLISHED?
3. IS THE RIGGING IN ACCEPTABLE CONDITION?
4. IS THE RIGGING APPROPRIATE FOR LIFTING?
5. DOES THE RIGGING HAVE PROPER IDENTIFICATION?
6. DOES ALL GEAR HAVE KNOWN WORKING LOAD LIMITS?
7. WHAT IS THE WEIGHT OF THE LOAD?
8. WHERE IS THE LOAD'S CENTER OF GRAVITY?
9. WHAT IS THE SLING ANGLE OF LOADING?
10. WILL THERE BE ANY SIDE OR ANGULAR LOADING?
11. ARE THE SLINGS PROTECTED FROM CORNERS, EDGES, PROTRUSIONS AND ABRASIVE SURFACES?
12. ARE THE WORKING LOAD LIMITS ADEQUATE?
13. IS THE LOAD RIGGED TO THE CENTER OF GRAVITY?
14. IS THE HITCH APPROPRIATE FOR THE LOAD?
15. IS A TAG LINE REQUIRED TO CONTROL THE LOAD?
16. WILL PERSONNEL BE CLEAR OF SUSPENDED LOADS?
17. IS THERE ANY POSSIBILITY OF FOULING?
18. WILL THE LOAD LIFT LEVEL AND BE STABLE?
19. ANY UNUSUAL ENVIRONMENTAL CONCERNS?
20. ANY SPECIAL REQUIREMENTS?

THE RIGGING MUST BE USED WITHIN MANUFACTURER'S RECOMMENDATIONS AND INDUSTRY STANDARDS THAT INCLUDE OSHA, ASME, ANSI, API AND OTHERS.

### RESPONSIBILITY

#### USER RESPONSIBILITY

1. UTILIZE APPROPRIATE RIGGING GEAR SUITABLE FOR OVERHEAD LIFTING.
2. UTILIZE THE RIGGING GEAR WITHIN INDUSTRY STANDARDS AND THE MANUFACTURER'S RECOMMENDATIONS.
3. CONDUCT REGULAR INSPECTION AND MAINTENANCE OF THE RIGGING GEAR.
4. PROVIDE EMPLOYEES WITH TRAINING TO MEET OSHA, API AND ASME (B30.9, B30.26, ETC.) REQUIREMENTS.

#### MANUFACTURER'S RESPONSIBILITY

1. PROVIDES PRODUCT AND APPLICATION INFORMATION
2. PROVIDES PRODUCT THAT IS CLEARLY IDENTIFIED
  - NAME OR LOGO
  - LOAD RATING AND SIZE
  - TRACEABILITY
3. PROVIDES PRODUCT PERFORMANCE
  - WORKING LOAD LIMIT
  - DUCTILITY
  - FATIGUE PROPERTIES
  - IMPACT PROPERTIES
4. PROVIDES PRODUCT TRAINING AND TRAINING RESOURCES



## INSPECTION OF RIGGING HARDWARE

### INSPECTION FREQUENCY PER ASME B30.26

A VISUAL INSPECTION SHALL BE PERFORMED BY THE USER OR DESIGNATED PERSON EACH DAY BEFORE THE RIGGING HARDWARE IS USED. A PERIODIC INSPECTION SHALL BE PERFORMED BY A DESIGNATED PERSON, AT LEAST ANNUALLY. THE RIGGING HARDWARE SHALL BE EXAMINED AND A DETERMINATION MADE AS TO WHETHER THEY CONSTITUTE A HAZARD. WRITTEN RECORDS ARE NOT REQUIRED. SEMI-PERMANENT AND INACCESSIBLE LOCATIONS WHERE FREQUENT INSPECTIONS ARE NOT FEASIBLE SHALL HAVE PERIODIC INSPECTIONS PERFORMED.

### REJECTION CRITERIA PER ASME B30.26

MISSING OR ILLEGIBLE MANUFACTURER'S NAME OR TRADEMARK AND/OR RATED LOAD IDENTIFICATION (OR SIZE AS REQUIRED)  
 A 10% OR MORE REDUCTION OF THE ORIGINAL DIMENSION  
 BENT, TWISTED, DISTORTED, STRETCHED, ELONGATED, CRACKED OR BROKEN LOAD BEARING COMPONENTS  
 EXCESSIVE NICKS, GOUGES, PITTING AND CORROSION  
 INDICATIONS OF HEAT DAMAGE INCLUDING WELD SPATTER OR ARC STRIKES, EVIDENCE OF UNAUTHORIZED WELDING  
 LOOSE OR MISSING NUTS, BOLTS, COTTER PINS, SNAP RINGS, OR OTHER FASTENERS AND RETAINING DEVICES  
 UNAUTHORIZED REPLACEMENT COMPONENTS OR OTHER VISIBLE CONDITIONS THAT CAUSE DOUBT AS TO THE CONTINUED USE OF THE SLING

#### ADDITIONALLY, INSPECT WIRE ROPE CLIPS FOR:

1. INSUFFICIENT NUMBER OF CLIPS
2. INCORRECT SPACING BETWEEN CLIPS
3. IMPROPERLY TIGHTENED CLIPS
4. INDICATIONS OF DAMAGED WIRE ROPE OR WIRE ROPE SLIPPAGE
5. IMPROPER ASSEMBLY

#### ADDITIONALLY, INSPECT WEDGE SOCKETS FOR:

1. INDICATIONS OF DAMAGED WIRE ROPE OR WIRE ROPE SLIPPAGE
2. IMPROPER ASSEMBLY

### ADDITIONAL REJECTION CRITERIA AND INFORMATION PER ASME B30.10 - HOOKS

- ANY VISIBLY APPARENT BEND OR TWIST FROM THE PLANE OF THE UNBENT HOOK
- ANY DISTORTION CAUSING AN INCREASE IN THROAT OPENING OF 5%, NOT TO EXCEED 1/4"
- MISSING OR ILLEGIBLE RATED LOAD IDENTIFICATION
- MISSING OR ILLEGIBLE HOOK MANUFACTURER'S IDENTIFICATION OR SECONDARY MFG. IDENTIFICATION
- HOOKS SHALL NOT BE RETURNED TO SERVICE UNTIL APPROVED BY A QUALIFIED PERSON
- HOOKS REQUIRE A WRITTEN RECORD OF THE PERIODIC INSPECTION, MINIMUM OF ONCE PER YEAR

## INSPECTION OF SLINGS

### INSPECTION FREQUENCY PER ASME B30.9

A VISUAL INSPECTION FOR DAMAGE SHALL BE PERFORMED BY A DESIGNATED PERSON EACH DAY OR SHIFT THE SLING IS USED. A COMPLETE INSPECTION FOR DAMAGE SHALL BE PERFORMED PERIODICALLY BY A DESIGNATED PERSON, AT LEAST ANNUALLY.

### REJECTION CRITERIA PER ASME B30.9

MISSING OR ILLEGIBLE SLING IDENTIFICATION; EVIDENCE OF HEAT DAMAGE; SLINGS THAT ARE KNOTTED; FITTINGS THAT ARE PITTED, CORRODED, CRACKED, BENT, TWISTED, GOUGED, OR BROKEN; OTHER CONDITIONS, INCLUDING VISIBLE DAMAGE, THAT CAUSE DOUBT AS TO THE CONTINUED USE OF THE SLING.

#### WIRE ROPE SLINGS

EXCESSIVE BROKEN WIRES, FOR STRAND-LAID AND SINGLE PART SLINGS, TEN RANDOMLY DISTRIBUTED BROKEN WIRES IN ONE ROPE LAY OR FIVE BROKEN WIRES IN ONE STRAND IN ONE ROPE LAY  
 SEVERE LOCALIZED ABRASION OR SCRAPING, KINKING, CRUSHING, BIRDCAGING  
 ANY OTHER DAMAGE RESULTING IN DAMAGE TO THE ROPE STRUCTURE  
 SEVERE CORROSION OF THE ROPE OR END ATTACHMENTS  
 DOCUMENTATION THAT THE MOST RECENT PERIODIC INSPECTION WAS PERFORMED SHALL BE MAINTAINED  
 INSPECTION RECORDS OF INDIVIDUAL SLINGS ARE NOT REQUIRED

#### CHAIN SLINGS

CRACKS OR BREAKS  
 EXCESSIVE WEAR, NICKS OR GOUGES  
 STRETCHED CHAIN LINKS OR COMPONENTS  
 BENT, TWISTED OR DEFORMED CHAIN LINKS OR COMPONENTS  
 EXCESSIVE PITTING OR CORROSION  
 LACK OF ABILITY OF CHAIN OR COMPONENTS TO HINGE FREELY  
 WELD SPATTER  
 A WRITTEN RECORD OF THE INITIAL INSPECTION REFERENCING INDIVIDUAL SLING IDENTIFICATION IS REQUIRED  
 A WRITTEN RECORD OF THE MOST RECENT PERIODIC INSPECTION SHALL BE MAINTAINED AND SHALL INCLUDE THE CONDITION OF THE SLING

#### WEB SLINGS

ACID OR CAUSTIC BURNS  
 MELTING OR CHARRING OF ANY PART OF THE SLING  
 HOLES, TEARS, CUTS OR SNAGS  
 BROKEN OR WORN STITCHING IN LOAD BEARING SPLICES  
 EXCESSIVE ABRASIVE WEAR DISCOLORATION AND BRITTLE  
 OR STIFF AREAS ON ANY PART OF THE SLING, WHICH  
 MAY MEAN CHEMICAL OR ULTRAVIOLET / SUNLIGHT DAMAGE  
 DOCUMENTATION THAT THE MOST RECENT PERIODIC INSPECTION WAS PERFORMED SHALL BE MAINTAINED

#### ROUND SLINGS

ACID OR CAUSTIC BURNS  
 EVIDENCE OF HEAT DAMAGE  
 HOLES, TEARS, CUTS, ABRASIVE WEAR OR SNAGS THAT EXPOSE THE CORE YARNS  
 BROKEN OR DAMAGED CORE YARNS  
 WELD SPATTER THAT EXPOSES CORE YARNS  
 DISCOLORATION AND BRITTLE OR STIFF AREAS ON ANY PART OF THE SLINGS, WHICH MAY MEAN CHEMICAL OR OTHER DAMAGE  
 DOCUMENTATION THAT THE MOST RECENT PERIODIC INSPECTION WAS PERFORMED SHALL BE MAINTAINED



## WIRE ROPE SLING CONNECTIONS AND HITCHES

### CONNECTION TO FITTINGS

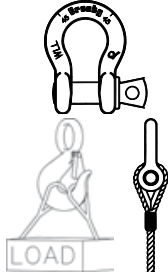

USE A THIMBLE TO PROTECT SLING AND INCREASE D/d

NEVER PLACE EYE OVER A FITTING WITH SMALLER DIAMETER OR WIDTH THAN THE ROPE'S DIAMETER.

NEVER PLACE A SLING EYE OVER A FITTING WITH A DIAMETER OR WIDTH GREATER THAN ONE HALF THE LENGTH OF THE EYE.

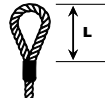

### CHOKER CAPACITY

A CHOKER HITCH HAS 75% OF THE CAPACITY OF A SINGLE LEG SLING ONLY IF THE ANGLE OF CHOKE IS 120 DEGREES OR GREATER. A CHOKE ANGLE LESS THAN 120 DEGREES CAN RESULT IN A CAPACITY AS LOW AS 40% OF THE SINGLE LEG.

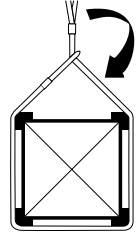

### BASKET HITCH CAPACITY

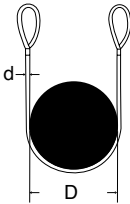

A BASKET HITCH HAS TWICE THE CAPACITY OF A SINGLE LEG ONLY IF D/d RATIO IS 25/1 AND THE LEGS ARE VERTICAL.

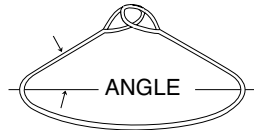

#### CAPACITY % OF ANGLE SINGLE LEG

90	200%
60	170%
45	140%
30	100%

### MULTIPLE LEG SLINGS

TRIPLE LEG SLINGS HAVE 50% MORE CAPACITY THAN DOUBLE LEG SLINGS (AT SAME SLING ANGLE) ONLY IF THE CENTER OF GRAVITY IS IN CENTER OF CONNECTION POINTS AND LEGS ARE ADJUSTED PROPERLY. THEY MUST HAVE AN EQUAL SHARE OF THE LOAD.

QUAD (4 LEG) SLINGS OFFER IMPROVED STABILITY BUT PROVIDE INCREASED CAPACITY ONLY IF ALL LEGS SHARE AN EQUAL SHARE OF THE LOAD.

## CHAIN SLING CONNECTIONS AND HITCHES

### CONNECTION TO FITTINGS

USE MASTER LINKS TO COLLECT SLINGS AND TO CONNECT TO HOOK

USE GRADE 8 (80) OR GRADE 10 (100) FITTINGS THAT MATCH THE WLL OF CHAIN AND OFFER PROPER SECUREMENT.

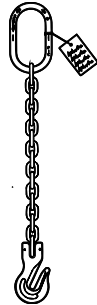

### CHOKER CAPACITY

A CHAIN CHOKER HITCH HAS 80% OF THE CAPACITY OF A SINGLE LEG SLING ONLY IF THE ANGLE OF CHOKE IS 120 DEGREES OR GREATER. RATED LOADS FOR ANGLES OF CHOKE LESS THAN 120 DEGREES SHALL BE DETERMINED BY THE SLING MFG OR A QUALIFIED PERSON.

NO LOSS IN CAPACITY RESULTS IF A CRADLE GRAB HOOK IS USED WHEN ANGLE OF CHOKE IS 120 DEGREES OR GREATER



### BASKET HITCH CAPACITY

A TRUE BASKET HITCH HAS TWICE THE CAPACITY OF A SINGLE LEG ONLY IF THE LEGS ARE VERTICAL. NOTE THAT THE BASKET IS FORMED BY USING A CHAIN SLING WITH TWO MASTERLINKS AT EACH END CONNECTED TO THE HOOK.

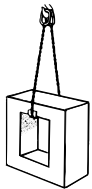

#### HORIZONTAL CAPACITY % OF ANGLE SINGLE LEG

90	200%
60	170%
45	140%
30	100%

### MULTIPLE LEG SLINGS

TRIPLE LEG CHAIN SLINGS HAVE 50% MORE CAPACITY THAN DOUBLE LEG CHAIN SLINGS (AT SAME SLING ANGLE) ONLY IF THE CENTER OF GRAVITY IS IN THE CENTER OF THE CONNECTION POINTS AND LEGS ARE ADJUSTED PROPERLY. THEY MUST HAVE AN EQUAL SHARE OF THE LOAD.

QUAD (4 LEG) CHAIN SLINGS OFFER IMPROVED STABILITY, BUT DO NOT PROVIDE INCREASED CAPACITY. THE CAPACITY OF A FOUR LEG CHAIN SLING IS CONSIDERED THE SAME AS THREE LEG CHAIN SLING.



## WEB SLING AND ROUND SLING CAPACITIES

WEB SLING IDENTIFICATION INCLUDES:

**SLING TYPE:**

TC - TRIANGLE CHOKER

TT - TRIANGLE TRIANGLE

EE - EYE AND EYE

EN - ENDLESS

NUMBER OF PLIES: 1 OR 2

WEBBING GRADE: 9 OR 6

SLING WIDTH (INCHES)

EE 2-9 04 X 12 ← SLING LENGTH (FEET)

ROUND SLING IDENTIFICATION INCLUDES:

**SLING NUMBER:** 1-13

SLING NUMBERS ARE FOR REFERENCE ONLY, SOME ROUND SLINGS HAVE DIFFERENT RATINGS.

**SLING COLOR:** PURPLE, GREEN, YELLOW, TAN, RED, WHITE, BLUE, ORANGE  
SLING COLOR IS NOT FOLLOWED BY ALL MANUFACTURERS AND SOME COLORS HAVE MORE THAN ONE RATED LOAD.

FOLDING, BUNCHING, OR PINCHING OF SYNTHETIC SLINGS, WHICH OCCURS WHEN USED WITH SHACKLES, HOOKS OR OTHER APPLICATIONS WILL REDUCE THE RATED LOAD.

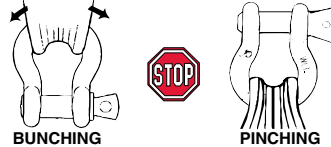

### CHOKER CAPACITY

A CHOKER HITCH HAS 80% OF THE CAPACITY OF A SINGLE LEG SLING ONLY IF THE ANGLE OF CHOKE IS 120 DEGREES OR GREATER. A CHOKE ANGLE LESS THAN 120 DEGREES WILL RESULT IN A CAPACITY AS LOW AS 40% OF THE SINGLE LEG.

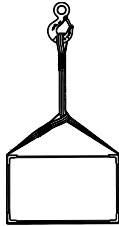

### BASKET HITCH CAPACITY

HORIZONTAL CAPACITY % OF ANGLE SINGLE LEG

90	200%
60	170%
45	140%
30	100%

A TRUE BASKET HITCH HAS TWICE THE CAPACITY OF A SINGLE LEG ONLY IF THE LEGS ARE VERTICAL

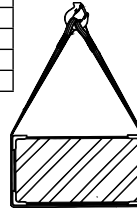

### MULTIPLE LEG SLINGS

TRIPLE LEG SLINGS HAVE 50% MORE CAPACITY THAN DOUBLE LEG SLINGS (AT SAME SLING ANGLE) ONLY IF THE CENTER OF GRAVITY IS IN THE CENTER OF CONNECTION POINTS AND LEGS ARE ADJUSTED PROPERLY. THEY MUST HAVE AN EQUAL SHARE OF THE LOAD.

QUAD (4 LEG) SLINGS OFFER IMPROVED STABILITY BUT PROVIDE INCREASED CAPACITY ONLY IF ALL LEGS SHARE AN EQUAL SHARE OF THE LOAD.

NEVER PLACE A SYNTHETIC SLING EYE OVER A FITTING WITH A DIAMETER OR WIDTH GREATER THAN ONE THIRD THE LENGTH OF THE EYE. CONSULT MANUFACTURER OR QUALIFIED PERSON WHEN EXPECTED LOAD ON SYNTHETIC SLING IS EXPECTED TO EXCEED 80% OF THE SLING RATED LOAD.

### CENTER OF GRAVITY AND SLING LOADING

WHEN LIFTING VERTICALLY, THE LOAD WILL BE SHARED EQUALLY IF THE CENTER OF GRAVITY IS PLACED EQUALLY BETWEEN THE PICK POINTS.

IF THE WEIGHT OF THE LOAD IS 10,000 LBS., THEN EACH SLING WILL HAVE A LOAD OF 5,000 LBS. AND EACH SHACKLE AND EYEBOLT WILL ALSO HAVE A LOAD OF 5,000 LBS.

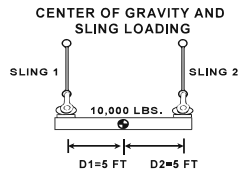

### WEIGHTS AND MEASURES

UNIT WEIGHT STEEL = 490 LBS/FT<sup>3</sup>  
 UNIT WEIGHT ALUMINUM = 165 LBS/FT<sup>3</sup>  
 UNIT WEIGHT CONCRETE = 150 LBS/FT<sup>3</sup>  
 UNIT WEIGHT WOOD = 50 LBS/FT<sup>3</sup>  
 UNIT WEIGHT WATER = 62 LBS/FT<sup>3</sup>  
 UNIT WEIGHT SAND AND GRAVEL = 120 LBS/FT<sup>3</sup>  
 UNIT WEIGHT COPPER = 560 LBS/FT<sup>3</sup>  
 UNIT WEIGHT OIL = 58 LBS/FT<sup>3</sup>

1 CUBIC FT. = 7.5 GALS                      1/2 INCH = 12.7 mm  
 1 METRIC TON = 1.1 US TONS            1 INCH = 25.4 mm  
 1 KILOGRAM = 2.2 LBS

### CENTER OF GRAVITY AND SLING LOADING

WHEN THE CENTER OF GRAVITY IS NOT EQUALLY SPACED BETWEEN THE PICK POINTS, THE SLING AND FITTINGS WILL NOT CARRY AN EQUAL SHARE OF THE LOAD. THE SLING CONNECTED TO THE PICK POINT CLOSEST TO THE CENTER OF GRAVITY WILL CARRY THE GREATEST SHARE OF THE LOAD.

SLING 2 IS CLOSEST TO COG. IT WILL HAVE THE GREATEST SHARE OF THE LOAD.

SLING 2 = 10,000 X 8 / (8+2) = 8,000 LBS.  
 SLING 1 = 10,000 X 2 / (8+2) = 2,000 LBS.

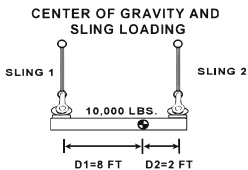

VOLUME OF RECTANGLE = HEIGHT x WIDTH x LENGTH

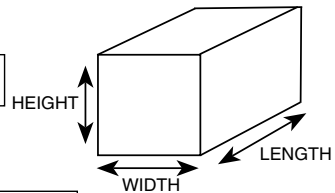

VOLUME OF SPHERE = 3.14 x (DIAM. x DIAM. x DIAM.) / 6

VOLUME OF CYLINDER = 3.14 x (DIAM. x DIAM. x LENGTH) / 4

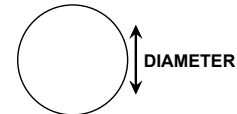

## SLING ANGLES

### TWO LEGGED SLING - WIRE ROPE, CHAIN, SYNTHETICS

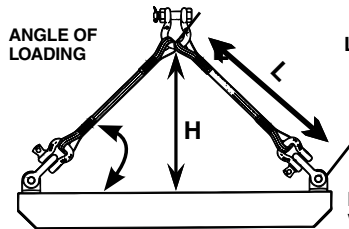
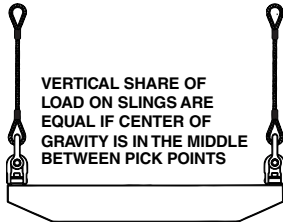

ANGLE OF LOADING (A) DEGREE	LOAD ANGLE FACTOR = L/H
90	1.000
60	1.155
50	1.305
45	1.414
30	2.000

LOAD ON EACH LEG OF SLING = VERTICAL SHARE OF LOAD X LOAD ANGLE FACTOR

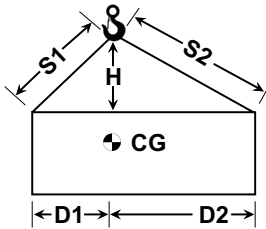

LOAD ON SLING CALCULATED  
 TENSION 1 = LOAD X D2 X S1/(H(D1+D2))  
 TENSION 2 = LOAD X D1 X S2/(H(D1+D2))

ANGLE OF LOADING OF LESS THAN 30 DEGREES ARE NOT RECOMMENDED REFER TO ASME B30.9 FOR FULL INFORMATION

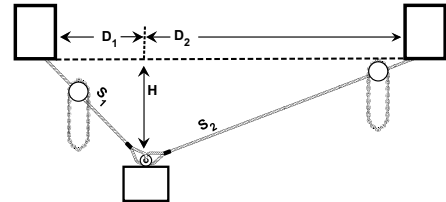

LOAD ON SLING CALCULATED  
 TENSION 1 = LOAD X D2 X S1/(H(D1+D2))  
 TENSION 2 = LOAD X D1 X S2/(H(D1+D2))

## OPERATING PRACTICES - ASME B30.9

WHENEVER ANY SLING IS USED, THE FOLLOWING PRACTICES SHALL BE OBSERVED.

1. SLINGS THAT ARE DAMAGED OR DEFECTIVE SHALL NOT BE USED.
2. SLINGS SHALL NOT BE SHORTENED OR LENGTHENED BY KNOTTING OR TWISTING.
3. SLING LEGS SHALL NOT BE KINKED.
4. THE RATED LOAD OF THE SLING SHALL NOT BE EXCEEDED.
5. SLINGS USED IN A BASKET HITCH SHALL HAVE THE LOADS BALANCED TO PREVENT SLIPPAGE.
6. SLINGS SHALL BE SECURELY ATTACHED TO THEIR LOAD.
7. SLINGS SHALL BE PROTECTED FROM EDGES, CORNERS, PROTRUSIONS AND ABRASIVE SURFACES TO PREVENT SLING DAMAGE.
8. DURING LIFTING, WITH OR WITHOUT LOAD, PERSONNEL SHALL BE ALERT FOR POSSIBLE SNAGGING.
9. ALL EMPLOYEES SHALL BE KEPT CLEAR OF LOADS ABOUT TO BE LIFTED AND OR SUSPENDED LOADS.
10. HANDS OR FINGERS SHALL NOT BE PLACED BETWEEN THE SLING AND ITS LOAD WHILE THE SLING IS BEING TIGHTENED AROUND THE LOAD.
11. SHOCK LOADING SHOULD BE AVOIDED.
12. A SLING SHALL NOT BE PULLED FROM UNDER A LOAD WHEN THE LOAD IS RESTING ON THE SLING.

INSPECTION: EACH DAY BEFORE BEING USED, THE SLING AND ALL FASTENINGS AND ATTACHMENTS SHALL BE INSPECTED FOR DAMAGE OR DEFECTS BY A COMPETENT PERSON DESIGNATED BY THE EMPLOYER. ADDITIONAL INSPECTIONS SHALL BE PERFORMED DURING SLING USE WHERE SERVICE CONDITIONS WARRANT. DAMAGED OR DEFECTIVE SLINGS SHALL BE IMMEDIATELY REMOVED FROM SERVICE.

## LOAD CONTROL

### POSITIVE LOAD CONTROL

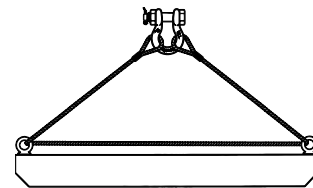
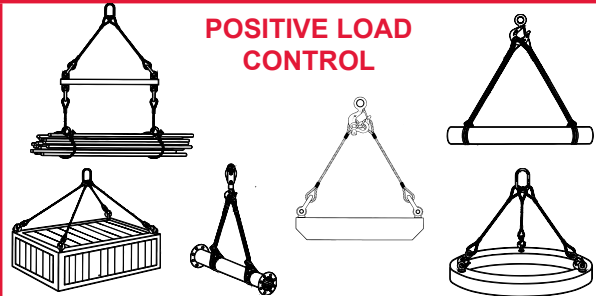

REEVING THROUGH CONNECTIONS TO LOAD INCREASES LOAD ON CONNECTION FITTINGS BY AS MUCH AS TWICE.

**DO NOT REEVE!**

VERSION  
(2/1/17)

## Crosby BLOCK SELECTION AND APPLICATION GUIDE

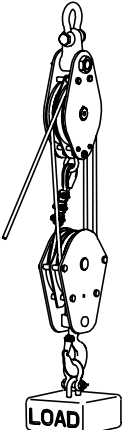
RISK MANAGEMENT	MECHANICAL ADVANTAGE AND TOTAL LOAD																									
<p>COMPREHENSIVE SET OF ACTIONS THAT REDUCES THE RISK OF A PROBLEM, A FAILURE, AN ACCIDENT</p> <p style="text-align: center;"><b>YOU NEED</b></p> <ul style="list-style-type: none"> <li>PRODUCT KNOWLEDGE</li> <li>APPLICATION KNOWLEDGE</li> <li>MANUFACTURER OF KNOWN CAPABILITY</li> <li>PRODUCTS THAT ARE CLEARLY IDENTIFIED WITH THE FOLLOWING:                             <ol style="list-style-type: none"> <li>MANUFACTURER'S NAME AND LOGO</li> <li>LOAD RATING OR SIZE THAT REFERENCES RATINGS</li> <li>TRACEABILITY CODE</li> </ol> </li> </ul> <p><b>A GOOD RISK MANAGEMENT PROGRAM RECOGNIZES</b></p> <ul style="list-style-type: none"> <li>PERFORMANCE REQUIREMENTS INCLUDE THE FOLLOWING:                             <ol style="list-style-type: none"> <li>LOAD RATED PRODUCTS</li> <li>QUENCHED AND TEMPERED</li> <li>ABILITY TO DEFORM WHEN OVERLOADED.</li> <li>ABILITY TO WITHSTAND REAL WORLD LOADING IN DAY TO DAY USE, TOUGHNESS.</li> </ol> </li> </ul>	<p>MECHANICAL ADVANTAGE IS THE LEVERAGE GAINED BY A MULTIPLE PART BLOCK. MUST HAVE A TRAVELING BLOCK TO HAVE MECHANICAL ADVANTAGE. THE THEORETICAL ADVANTAGE IS EQUAL TO THE NUMBER OF PARTS OF LINE SUPPORTING THE TRAVELING BLOCK.</p> 	<p style="text-align: center;"><b>TRUE MECHANICAL ADVANTAGE</b></p> <table border="1"> <thead> <tr> <th>ADVANTAGE FOR BRONZE BUSHING</th> <th>ADVANTAGE FOR ANTI FRICTION</th> <th>NUMBER OF LINE PARTS</th> </tr> </thead> <tbody> <tr><td>5.16</td><td>5.60</td><td>6</td></tr> <tr><td>5.90</td><td>6.47</td><td>7</td></tr> <tr><td>6.60</td><td>7.32</td><td>8</td></tr> <tr><td>7.27</td><td>8.16</td><td>9</td></tr> <tr><td>7.91</td><td>8.98</td><td>10</td></tr> <tr><td>8.52</td><td>9.79</td><td>11</td></tr> <tr><td>9.11</td><td>10.60</td><td>12</td></tr> </tbody> </table> <p style="text-align: center;"><b>TOTAL LOAD</b></p> <p>THE TOTAL LOAD PLACED ON THE BLOCK AND ITS END FITTING DETERMINES THE WORKING LOAD LIMIT REQUIRED.</p> <p style="text-align: center;">2801 DAWSON RD, TULSA, OK, USA (918) 834-4611 FAX (918) 832-0940 WWW.THECROSBYGROUP.COM</p>	ADVANTAGE FOR BRONZE BUSHING	ADVANTAGE FOR ANTI FRICTION	NUMBER OF LINE PARTS	5.16	5.60	6	5.90	6.47	7	6.60	7.32	8	7.27	8.16	9	7.91	8.98	10	8.52	9.79	11	9.11	10.60	12
ADVANTAGE FOR BRONZE BUSHING	ADVANTAGE FOR ANTI FRICTION	NUMBER OF LINE PARTS																								
5.16	5.60	6																								
5.90	6.47	7																								
6.60	7.32	8																								
7.27	8.16	9																								
7.91	8.98	10																								
8.52	9.79	11																								
9.11	10.60	12																								

### WORKING WITH BLOCKS

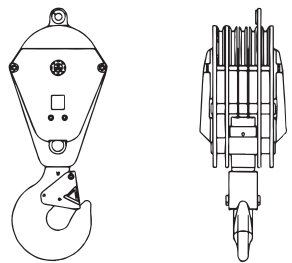
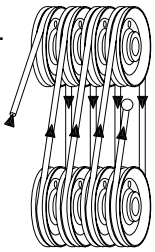
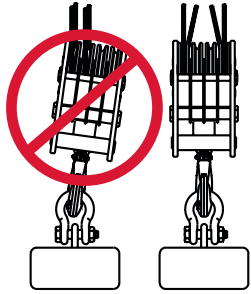
OVERHAUL WEIGHT	BLOCK REAVING	SYMMETRICAL REEVING
 <p>To determine the weight of the block or overhaul ball that is required to free fall the block, the following information is needed: <b>Size of wire rope, Number of line parts, Type of sheave bearing, Length of crane boom, and Drum Friction.</b></p>	<p>Straight laced reeving is a basic method of placing the rope through a set of blocks. The end of the rope is fed through the outside sheave of the upper block to the outside sheave of the lower (traveling) block. This continues to the last sheave.</p> <p><b>ADVANTAGES:</b></p> <ol style="list-style-type: none"> <li>Allows blocks to run closer together.</li> <li>Is simple.</li> <li>Has no reverse bends.</li> </ol> <p><b>DRAWBACKS:</b></p> <p>Tilting because of imbalanced loading can cause block rotation and wear of the sheaves and wire rope</p> 	 <p>Reeve blocks symmetrically to distribute load evenly. All sheaves must be reeved to achieve the full working load limit of the block.</p> <p><b>BLOCK CABLING</b></p> <ol style="list-style-type: none"> <li>Reduce wire rope length</li> <li>Use even part reeving</li> <li>Dead end to boom</li> <li>Evaluate wire rope construction</li> </ol>

**FOR ADDITIONAL INFORMATION REFER TO THE CROSBY GENERAL CATALOG**

## RIGGING WITH BLOCKS

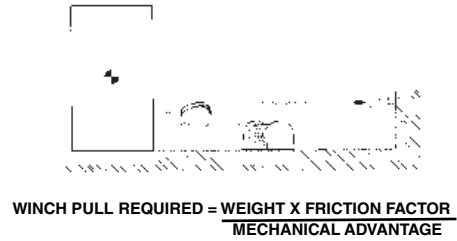
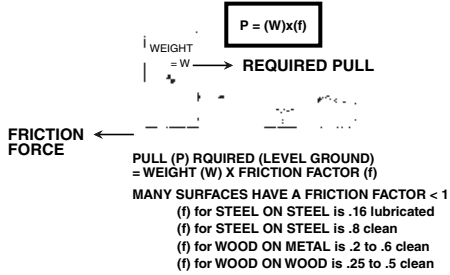
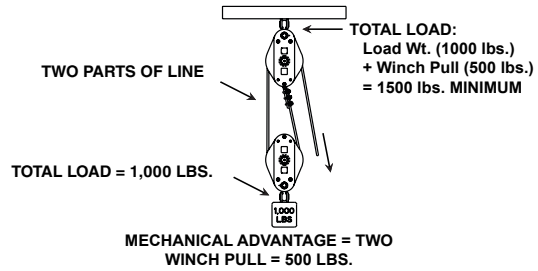
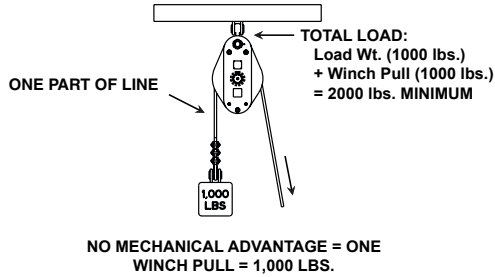

## BLOCK LOADING - ANGLE FACTOR MULTIPLIERS

A single line sheave block used to change load line direction can be subject to total loads greatly different from the line pull

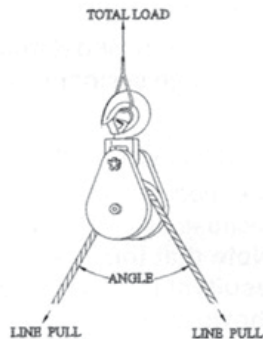

### ANGLE FACTOR MULTIPLIERS

ANGLE	FACTOR	ANGLE	FACTOR
0°	2.00	100°	1.29
10°	1.99	110°	1.15
20°	1.97	120°	1.00
30°	1.93	130°	.84
40°	1.87	135°	.76
45°	1.84	140°	.68
50°	1.81	150°	.52
60°	1.73	160°	.35
70°	1.64	170°	.17
80°	1.53	180°	.00
90°	1.41	—	—

TOTAL LOAD = LINE PULL X ANGLE FACTOR  
 EXAMPLE, AT 45 DEGREES, AND 10,000 LB LINE PULL,  
 TOTAL LOAD = 10,000 X 1.84 = 18,400 LBS.

FOR ADDITIONAL INFORMATION REFER TO THE CROSBY GENERAL CATALOG



## SHEAVE INSPECTION

### SHEAVE INSPECTION

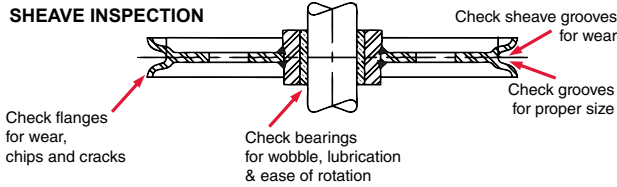

### CHECKING GROOVE SIZE FOR PROPER SIZE

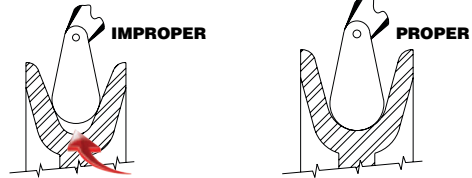

### SHEAVE INSPECTION Minimum groove radii for worn sheave tolerances per "Wire Rope User's Manual" (third edition)

NOMINAL WIRE ROPE SIZE (in.)	RADII (in.)	NOMINAL WIRE ROPE SIZE (in.)	RADII (in.)
1/4	.128	3/4	.384
5/16	.160	7/8	.448
3/8	.192	1	.513
7/16	.224	1-1/8	.577
1/2	.256	1-1/4	.641
9/16	.266	1-3/8	.705
5/8	.320	1-1/2	.769

### SHEAVE FLEET ANGLE\*

- Fleet Angle is the entrance and exit angle of the wire rope relative to the sheave
- Fleet angle should be no more than 1-1/2 degrees

### FLEET ANGLE

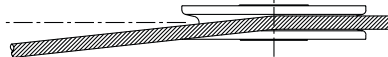

\* NOTE: "Wire Rope User's Manual" allows 2 degrees on grooved winch drums.

FOR ADDITIONAL INFORMATION REFER TO THE CROSBY GENERAL CATALOG

## BLOCK HOOK INSPECTION

### CROSBY RECOMMENDS AS A MINIMUM:

- A visual inspection for cracks, nicks, wear, gouges and deformation as part of a comprehensive documented inspection program, should be conducted by trained personnel in compliance with the schedule in ASME B30.10.
- For hooks used in frequent load cycles or pulsating load, or exposed to corrosive conditions (Road Salt, etc.) the hook and thread should be periodically inspected by Magnetic Particle or Dye Penetrant.

### LUBRICATION OF HOOK BEARINGS:

**Anti Friction** — Every 14 days for frequent swiveling; every 45 days for infrequent swiveling.

**Bronze Thrust Bushing or No Bearing** — Every 16 hours for frequent swiveling; every 21 days for infrequent swiveling.

### ASME B30.10 INSPECTION FREQUENCY

- Initial Inspection** - prior to use, all new, altered, modified, or repaired hooks shall be inspected to verify compliance with the applicable provisions in ASME B30.10 by a designated person. Written records are not required.
- Frequent Inspection** - shall include observations during operation by a designated person. Written records are not required.
  - Normal service - monthly. Normal service is operating at less than 85 percent of rated load except for isolated instances.
  - Heavy service - weekly to monthly. Heavy service is operating at 85 to 100 percent of rated load as a regular specified procedure.
  - Severe service - daily to weekly. Severe service is heavy service coupled with abnormal operating conditions.
- Periodic Inspection** - a complete visual inspection by a designated person. Disassembly may be required. Periodic inspection interval shall not exceed one year except as approved by a qualified person. Written records are required. (See definition of services above).
  - Normal service - yearly with equipment in place.
  - Heavy service - semi-annually, with equipment in place unless external conditions indicate need for disassembly.
  - Severe service - quarterly with equipment in place unless external conditions indicate the need for disassembly. Detailed inspection may show the need for a non-destructive test.

Note: Hooks that do not meet manufacture or ASME B30.10 requirements should be removed from service. Hooks shall not be returned to service until approved by a qualified person.

FOR ADDITIONAL INFORMATION REFER TO ASME B30.10 AND OSHA 1910.179 OVERHEAD GANTRY CRANES

Alloy Chain .....	227, 242
Angular Contact Bearing Swivels.....	138-140
Barrel Hooks .....	134
Bolts —	
Machinery Eye Bolts .....	169
Regular Eye .....	167
Shoulder Eye .....	168-170
Rivet Eye .....	170
Pad Eye .....	171
Bullard Hooks.....	124-129, 264
Bundle Clips.....	173
Button Spelter Sockets.....	40
Chain.....	227, 242
Boomer.....	262
Grade 80 .....	242
Grade 100.....	227
Master Links .....	160-164
Chain Shortener Link .....	237
Chain Sling Information .....	219-221
Chain Swivels .....	135
Clamps.....	409-428
Clips —	
Crosby “Red U-Bolt” .....	34
Fist Grip .....	35
Closed Wire Rope Sockets .....	43, 48
Connecting Links .....	227, 237, 253, 254, 255
Coupler Link.....	237
<b>Crosby Clamp-Co —</b>	
Barrier Grab .....	434
Beam Clamps.....	433
Curb Grab.....	434
Pipe Grab.....	430 - 432
Pipe Hook.....	435
Crosby Communication System .....	13, 17
<b>Crosby IP Clamps —</b>	
Beam Clamps.....	419-422
Drum Clamps .....	423
Horizontal Clamps.....	414-418
Misc. Clamps —	
Screw Style .....	428
Stinger Assembly.....	428
Shipbuilding	
Bulb Profile .....	425, 427
Ship Sections .....	426
Vertical Clamps.....	410-413, 424
Crosby Product Bulletins —	
How to Assemble Alloy Fittings.....	276
What It Takes To Be	
“Crosby or Equal” .....	15, 18, 20, 22, 24, 32, 74, 156, 306
Quality Continuum.....	16
World Standards.....	18-19
Identification .....	20-21
Heat Treatment .....	22-23
Material Properties .....	24-25
Product Warnings .....	27-30
Forged Wire Rope Clips .....	32-33
Shackles .....	74-94
Hoist Hooks .....	112-120, 124-132, 134
McKissick & Lebus Snatch Blocks .....	306-307
Turnbuckles .....	156-157
Crosby Product Warnings —	
Warning Elements .....	27-30
Warning Colors.....	30
Warning Format .....	29
<b>Crosby Trawlex.....</b>	<b>437-446</b>
Profile Chai .....	440
Connectors .....	441
Double Clevis Links .....	255
End Links .....	165
Eyes —	
Lifting .....	172
Eye Nut.....	172
Pad Eye .....	171
Eye Bolts .....	167-170
Fist Grip Clips .....	35
Hoist Rings .....	174-187
Hooks —	
Grade 80.....	118, 229-238, 247
Grade 100.....	119, 120, 228-238
Barrel .....	134
Bullard .....	124-129, 264
Chain Nest.....	263-264
Choker .....	133
Clevis Grab .....	233, 256
Clevis Sling .....	231
Clevis Slip .....	257
Duplex Hook Assemblies.....	455
Eye.....	114-120, 133, 134, 229, 230, 232, 234-236, 238, 247, 256
Eye Grab .....	229, 256
Eye Sling .....	230
Eye Slip .....	257
Foundry .....	232
Latching Clevis .....	235, 247
Latching Eye .....	118, 235, 247
Replacement .....	134
Round Reverse Eye .....	133
ROV .....	130-131
Shank .....	51, 112-113, 118, 128-129
SHUR-LOC® .....	118-120, 234-236
Snap .....	133
Sling .....	134, 232
Sorting .....	134
Swivel .....	116-117, 119-120, 126, 132, 134, 234, 236, 264
Utility .....	132
Web Slings .....	102
Web Choker.....	103
Weld-On.....	132
Latch Assemblies —	
4320.....	121, 248
Alloy .....	123, 248
PL .....	122
SS-4055.....	123
Lifting Clamps.....	409-435
Lifting Eyes .....	172
Lifting Point (SL-150).....	187
Links .....	160-166, 228, 243-246
Lok-A-Loy 6 Connecting Links .....	253
Lok-A-Loy 10 Connecting Links .....	227
Machinery Eye Bolts .....	169

Master Links .....	160-164, 228-229, 243-246
Missing Links .....	254
Mooring Sockets .....	41
Nuts —	
Eye .....	17
Open Wire Rope Sockets .....	42, 47
Pad Eyes .....	171
Pear Shape Missing Link .....	254
Plate Clamps .....	410-418, 428
Product Warnings —	
Bundle Clips .....	213-214
Chain Slings .....	266-268
Crosby/Bullard Hooks .....	146-147
Crosby Clip .....	56
Crosby Eliminator .....	269-270
Crosby Fist Grip Clips .....	57
Crosby PL Hook Latch Kit .....	151-152
Crosby S-4320 Latch Kit .....	141
Crosby SS-4055 Latch Kit .....	150
Crosby S-4338 Latch Kit .....	265
Forged Eye Bolts .....	200-201
Hoist Hooks .....	142-145
Die Information .....	69-72
Load Binders .....	271
Pivot Hoist Rings .....	202-203
ROV Hook .....	153-154
Sidepull Hoist Rings .....	206-207
Slide-Loc Lifting Point .....	215-216
Split Nut .....	144-145
Swageable Hooks .....	61-62
Swivel Hoist Rings .....	210-212
SHUR-LOC® Hooks .....	272-273
Tackle Blocks .....	381-388
Tailchain .....	274-275
Trench Plate Hoist Ring .....	204-205
Tubing Grab .....	389-390
WIRELOCK® .....	63-64
Wedge Sockets .....	58-60
Weld-on Hooks .....	148-149
Weld-on Links .....	208-209
Red-U-Bolt (Crosby Clip) .....	34
Regular Forged Swivels .....	135
Replacement Hooks (for Chain Hoists) .....	263-264
Replacement Links .....	254
Rings .....	165
Rivet Eye Bolts .....	170
ROV Handles .....	91
ROV Hooks .....	130-131
ROV Shackles .....	90
Shackles .....	73-94
Application Information .....	92-94
Cold Tuff Shakles .....	87
Bolt Type Shackles .....	79-82
General Information .....	74-75
Grommet Shakles .....	86
Screw Pin Shackles .....	77-78
Subsea Shackles .....	90-91
Theatrical Shackle .....	89
Wide Body Shackle .....	84-85
Shoulder Eye Bolts .....	168-170
SHUR-LOC® Eye Hook .....	118-120, 234-235
SHUR-LOC® with Handle .....	120, 234

Slide-Loc (SL-150) .....	187
Sling I.D. Tags .....	238
Sling Links .....	160-164, 228, 243-246
Sling Saver —	
Link Plate .....	101
Spool .....	101
Sliding Choker Hook .....	103
Web Sling Hook .....	102
Web Sling Shackle .....	99-100
Web Sling System .....	106-107
Web to Chain Connector .....	103
Web to Web Connector .....	104
Sockets .....	36-43
Spectrum Chain .....	227, 242
Spelter Sockets .....	40-43
Super Terminator .....	38-39
Swage Sockets .....	47-48
Swivels —	
Angular Contact Bearing Swivel .....	138-140
Forged Swivel .....	135
Tapered Roller/Thrust Bearing .....	136-137
Swivel Hoist Rings .....	174-187
Synthetic Sling Saver Shackle .....	99-100
Terminator .....	39
Thimbles .....	158-159
Theatrical Shackles .....	89
Turnbuckles .....	189-198
Twin Clevis Link .....	255
Vitalife Wire Rope Lubricant .....	199
Wedge Sockets .....	36-37
Weldless Links and Rings .....	165-166
Weld-on Hooks .....	132
Weld-on Pivot Links .....	187
Wire Rope Clips .....	34-35
Wire Rope Terminations .....	31-54
Wirelock® Resin .....	54

## **LEBUS LOAD BINDERS**

Load Binders .....	258-261
Load Binder Application Instructions .....	271
Snatch Blocks .....	361-367
Winchline Tail Chain .....	262

## **MCKISSICK® BLOCKS & SHEAVES**

Blocks for Every Purpose	
Bridge Crane Blocks .....	350-353, 460
Construction Blocks .....	338-348
Crane and Hook Blocks .....	310-330
Drilling .....	375-376
Hoist .....	310-335
Hay Fork Pulley Blocks .....	370
Oilfield .....	371-377
Scrap Handling Blocks .....	335
Snatch Blocks .....	361-369
Tilt-Up Wall Blocks .....	336
Toggle (Tail Board) Blocks .....	361-369
Tower .....	371
Tubing Blocks .....	372

*(For additional blocks see Western Section.)*

Block Warning, Use and Maintenance .....	381-388
Fairleaders .....	406
General Block Information .....	381-388

How to Determine Overhauling Weights.....	387	Marine Blocks —	
How to Figure Line Parts .....	387-388	Cargo Hoisting .....	402-403
How to Order McKissick Blocks and Sheaves .....	308	Western Fittings .....	403
How Sheave Size Affects Wire Rope Strength .....	386	Fairleaders.....	406
Loads on Blocks .....	384-385	Flag Blocks .....	405
Reeving of Tackle blocks .....	385	Hinged Lead Blocks .....	405
Overhaul Balls .....	354-359	Horizontal Lead Blocks .....	404
Pull Test Capabilities .....	391	Lead Blocks .....	404-405
Rigging Information .....	469-476	Miscellaneous —	
Sheaves —		Adjuster Fitting for Heel and Lead Block .....	403
AISE.....	302	Block Maintenance.....	381-388
API Standards.....	285	Fittings for Western Cargo Blocks .....	403
Bearings .....	279, 286	Fittings for Manila or Wire Rope Blocks.....	408
Bronze Bushed .....	293-297	Ordering Instructions .....	394
Closed Die Forged Sheaves .....	284	Training Information .....	380
Common Bore .....	291-292	Pressure Lube Fittings —	
Deck Mounted Lead .....	406	Snatch Blocks .....	395
Domed Sheaves .....	283	Trynet Blocks .....	400
Ductile Iron Sheaves .....	284	Trawl Blocks .....	401
Fabricated Sheaves.....	283	Vertical Lead Blocks .....	404
Finished Bore .....	288-290	Lead Blocks .....	404-405
Groove Profile .....	279, 285	Sheaves —	
Metric Sheaves.....	303	Iron for Manila Rope —	
Oilfield Sheave .....	300-301	For Snatch Blocks .....	304
Ordering Information .....	287	Iron for Wire Rope —	
Roll Forged Sheaves.....	282	For Snatch Blocks .....	304
Roller Bearing .....	297-298	Steel Sheaves .....	304
Tapered Bearing .....	299	For Wire Rope Snatch Blocks .....	304
Western.....	304	For Manila Rope Snatch Blocks .....	304
Special Blocks .....	370	Ordering Instructions .....	287
Split Overhaul Balls .....	358		
Trawling Blocks .....	401		
Try Net Blocks .....	400		
Wedge Socket.....	36-39		
<b><u>NATIONAL SWAGE FITTINGS</u></b>			
Duplex Non-Tapered Sleeve .....	50		
Standard Steel Swaging Sleeves .....	44-46		
Swage Button .....	49		
Swage Sockets.....	47-48		
<b><u>WESTERN BLOCKS &amp; SHEAVES</u></b>			
Blocks for Manila Rope —			
Manila Rope Fittings .....	408		
Painters Blocks .....	399		
Snatch Blocks .....	398		
Steel Shell —			
Gin Pole Blocks .....	399		
Snatch Blocks .....	398		
Standard Steel Blocks .....	397		
Synthetic Fiber Rope Blocks .....	397		
Wood Shell —			
Painters Blocks .....	399		
Snatch Blocks .....	398		
Blocks for Wire Rope —			
Steel Shells —			
Cargo Hoisting Blocks.....	402		
Wire Rope Fittings.....	403		
Try Net Blocks .....	400		
Double Rig Trawl Blocks .....	401		



## CROSBY

AS 1-17	138 - 140
AS-15	358
Bullard	124-129, 264
C-180	262
C-188	262
Crosby ClampCo	429-435
Crosby Easy-Loc	83, 85-86
Crosby IP	410-428
Crosby Trawlex	437-442
PL, PN -N/O	122
S-8 (Alloy)	242
S-10 (Alloy)	227
S-1 to S-6	136-139
SL-150	187
Sling I.D. tag	238
Vitalife	199
100	183
125	174-176, 180-181
209	77-78, 89
210	77
213	76
215	76
223	189
225	190
226	191
227	192
228	193
237	104
238	104
247	255
249	255
251	198
252 - 253	100
255	101
256	101
264	171
265	187
276	170
277	168
279	169
280	98
281	99
287	103
291	167
293	170
313	132
314 - 315	247
318	263
319	51, 112-113, 263
320	102, 114-115, 130
322	116
323	256
330	256
331	257
334	254
335	254
336	253
340	165
341	166
342	160, 243
344	162, 245
345	161, 244
347	163, 246
350	133
377	134
378	134
400	172
402 - 403	135
405	172
408	159
411 - 412	159
414	158
416	42
416-7 (WIRELOCK®)	54
417	43
421	36
422	37

423	39
427	40
429	35
450	34
460 - 461	173
500	182
501	47
502	48
517	41
562	131
643	165
720	363
1000	177-179
1200	184
1210	133
1311N	237
1316	118, 235
1316AH	120, 234
1317	235
1318	118
1325	237
1326	119, 236
1327	230
1328	229
1329	232
1337	227
1338	233
1339	231
1342	228
1345	228
1355	238
1358	233
1359	232
1361	225
1362	225
2100	90
2110	90
2130	79, 81, 88
2131	407
2140	82-83, 88
2150	80
2160	84-85
2169	78
2170	86
2510	197
3315	133
3316	134
3319	132
3322B	117
4037	194-196
4055	123
4060	198
4061	198
4088	123, 248
4104	225
4320	121, 248
4338	248
13326	119, 236
13326AH	120, 234

## LEBUS

A-1W	260
L-140	259
L-150	258, 261
L-160	361, 363, 365
L-170	361, 363, 365
L-180	262
R-10	260

## MCKISSICK

Drilling Blocks	375-376
Easy Reeve Crane Blocks	325-330
Scrap Handling Block	335
RJ	375
RP	376
HF-1 TO HF-14	370
SHB	358

Sheaves	278-304
TGRB	378
TU 481-484	336
UB500	354-357
UB550	359
70 Series	372
80 Series	372
171	370
241 - 243	374
380 Series	310-330
381 Series	335
401	366
402	365
404	365
406	366
407	366
408, 409	367
416	363
417	361
418	364
419	361, 362
420	364, 365
421	362
422	37, 354, 356
430	364
431	362
434	364
435	362
443	370
452	401
457	406
458 - 459	377
461	406
463	406
475	373
491	371
480 Series	336
680 Series	338-348
720	363
731 - 734	374
741 - 745	374
750 Series	350-353

## WESTERN

21 - 23	396
130	399
135	399
261 - 263	397
301 - 303	396
350	399
385	398
390	398
411 - 413	397
566	402-403
600 - 601	404
602 - 603	405
F453	400
F454	400
J454	400
J452	401
681 - 683	407
1101 - 1103	304
1141 - 1143	304
1192	304
1210	133
1293	304
1298	304
Sheaves	304
2131	407

## NATIONAL

409	49
501	47
502	48
505	44-45
506	50